



## STM32F101xx, STM32F102xx, STM32F103xx, STM32F105xx and STM32F107xx advanced ARM-based 32-bit MCUs

### Introduction

This reference manual targets application developers. It provides complete information on how to use the STM32F101xx, STM32F102xx, STM32F103xx and STM32F105xx/STM32F107xx microcontroller memory and peripherals. The STM32F101xx, STM32F102xx, STM32F103xx and STM32F105xx/STM32F107xx will be referred to as STM32F10xxx throughout the document, unless otherwise specified.

The STM32F10xxx is a family of microcontrollers with different memory sizes, packages and peripherals.

For ordering information, mechanical and electrical device characteristics please refer to the low-, medium-, high- and XL-density *STM32F101xx and STM32F103xx* datasheets, to the low- and medium-density STM32F102xx datasheets and to the STM32F105xx/STM32F107xx connectivity line datasheet.

For information on programming, erasing and protection of the internal Flash memory please refer to:

- *RM0042, the Flash programming manual for low-, medium- high-density and connectivity line STM32F10xxx devices*
- *PM0068, the Flash programming manual for XL-density STM32F10xxx devices.*

For information on the ARM Cortex™-M3 core, please refer to the *STM32F10xxx Cortex™-M3 programming manual (PM0056)*.

### Related documents

Available from [www.st.com](http://www.st.com):

- *STM32F101xx, STM32F102xx, STM32F103xx, STM32F105xx/STM32F107xx and datasheets*
- *STM32F10xxx Cortex™-M3 programming manual (PM0056)*
- *STM32F10xxx Flash programming manual (PM0042)*
- *STM32F10xxx XL-density Flash programming manual (PM0068)*

# Contents

- 1 Documentation conventions ..... 40**
  - 1.1 List of abbreviations for registers ..... 40
  - 1.2 Glossary ..... 40
  - 1.3 Peripheral availability ..... 40
  
- 2 Memory and bus architecture ..... 41**
  - 2.1 System architecture ..... 41
  - 2.2 Memory organization ..... 43
  - 2.3 Memory map ..... 44
    - 2.3.1 Embedded SRAM ..... 47
    - 2.3.2 Bit banding ..... 47
    - 2.3.3 Embedded Flash memory ..... 48
  - 2.4 Boot configuration ..... 54
  
- 3 CRC calculation unit ..... 56**
  - 3.1 CRC introduction ..... 56
  - 3.2 CRC main features ..... 56
  - 3.3 CRC functional description ..... 57
  - 3.4 CRC registers ..... 57
    - 3.4.1 Data register (CRC\_DR) ..... 57
    - 3.4.2 Independent data register (CRC\_IDR) ..... 57
    - 3.4.3 Control register (CRC\_CR) ..... 58
    - 3.4.4 CRC register map ..... 58
  
- 4 Power control (PWR) ..... 59**
  - 4.1 Power supplies ..... 59
    - 4.1.1 Independent A/D converter supply and reference voltage ..... 60
    - 4.1.2 Battery backup domain ..... 61
    - 4.1.3 Voltage regulator ..... 62
  - 4.2 Power supply supervisor ..... 62
    - 4.2.1 Power on reset (POR)/power down reset (PDR) ..... 62
    - 4.2.2 Programmable voltage detector (PVD) ..... 62
  - 4.3 Low-power modes ..... 64

4.3.1	Slowing down system clocks	64
4.3.2	Peripheral clock gating	65
4.3.3	Sleep mode	65
4.3.4	Stop mode	66
4.3.5	Standby mode	67
4.3.6	Auto-wakeup (AWU) from low-power mode	69
4.4	Power control registers	69
4.4.1	Power control register (PWR_CR)	69
4.4.2	Power control/status register (PWR_CSR)	71
4.4.3	PWR register map	72
<b>5</b>	<b>Backup registers (BKP)</b>	<b>73</b>
5.1	BKP introduction	73
5.2	BKP main features	73
5.3	BKP functional description	74
5.3.1	Tamper detection	74
5.3.2	RTC calibration	74
5.4	BKP registers	75
5.4.1	Backup data register x (BKP_DRx) (x = 1 ..42)	75
5.4.2	RTC clock calibration register (BKP_RTCCR)	75
5.4.3	Backup control register (BKP_CR)	76
5.4.4	Backup control/status register (BKP_CSR)	76
5.4.5	BKP register map	77
<b>6</b>	<b>Low-, medium-, high- and XL-density reset and clock control (RCC)</b>	<b>81</b>
6.1	Reset	81
6.1.1	System reset	81
6.1.2	Power reset	82
6.1.3	Backup domain reset	82
6.2	Clocks	83
6.2.1	HSE clock	85
6.2.2	HSI clock	86
6.2.3	PLL	86
6.2.4	LSE clock	87
6.2.5	LSI clock	87
6.2.6	System clock (SYSCLK) selection	88

6.2.7	Clock security system (CSS)	88
6.2.8	RTC clock	88
6.2.9	Watchdog clock	89
6.2.10	Clock-out capability	89
6.3	RCC registers	89
6.3.1	Clock control register (RCC_CR)	90
6.3.2	Clock configuration register (RCC_CFGR)	92
6.3.3	Clock interrupt register (RCC_CIR)	95
6.3.4	APB2 peripheral reset register (RCC_APB2RSTR)	97
6.3.5	APB1 peripheral reset register (RCC_APB1RSTR)	99
6.3.6	AHB peripheral clock enable register (RCC_AHBENR)	102
6.3.7	APB2 peripheral clock enable register (RCC_APB2ENR)	103
6.3.8	APB1 peripheral clock enable register (RCC_APB1ENR)	105
6.3.9	Backup domain control register (RCC_BDCR)	108
6.3.10	Control/status register (RCC_CSR)	109
6.3.11	RCC register map	111
<b>7</b>	<b>Connectivity line devices: reset and clock control (RCC)</b>	<b>112</b>
7.1	Reset	112
7.1.1	System reset	112
7.1.2	Power reset	113
7.1.3	Backup domain reset	114
7.2	Clocks	114
7.2.1	HSE clock	116
7.2.2	HSI clock	117
7.2.3	PLLs	118
7.2.4	LSE clock	118
7.2.5	LSI clock	119
7.2.6	System clock (SYSCLK) selection	119
7.2.7	Clock security system (CSS)	120
7.2.8	RTC clock	120
7.2.9	Watchdog clock	120
7.2.10	Clock-out capability	121
7.3	RCC registers	121
7.3.1	Clock control register (RCC_CR)	121
7.3.2	Clock configuration register (RCC_CFGR)	123
7.3.3	Clock interrupt register (RCC_CIR)	126

7.3.4	APB2 peripheral reset register (RCC_APB2RSTR) . . . . .	129
7.3.5	APB1 peripheral reset register (RCC_APB1RSTR) . . . . .	130
7.3.6	AHB Peripheral Clock enable register (RCC_AHBENR) . . . . .	133
7.3.7	APB2 peripheral clock enable register (RCC_APB2ENR) . . . . .	134
7.3.8	APB1 peripheral clock enable register (RCC_APB1ENR) . . . . .	136
7.3.9	Backup domain control register (RCC_BDCR) . . . . .	138
7.3.10	Control/status register (RCC_CSR) . . . . .	140
7.3.11	AHB peripheral clock reset register (RCC_AHBRSTR) . . . . .	141
7.3.12	Clock configuration register2 (RCC_CFGR2) . . . . .	142
7.3.13	RCC register map . . . . .	144
<b>8</b>	<b>General-purpose and alternate-function I/Os (GPIOs and AFIOs) . .</b>	<b>146</b>
8.1	GPIO functional description . . . . .	146
8.1.1	General-purpose I/O (GPIO) . . . . .	148
8.1.2	Atomic bit set or reset . . . . .	148
8.1.3	External interrupt/wakeup lines . . . . .	149
8.1.4	Alternate functions (AF) . . . . .	149
8.1.5	Software remapping of I/O alternate functions . . . . .	149
8.1.6	GPIO locking mechanism . . . . .	149
8.1.7	Input configuration . . . . .	150
8.1.8	Output configuration . . . . .	150
8.1.9	Alternate function configuration . . . . .	151
8.1.10	Analog configuration . . . . .	152
8.1.11	Peripherals' GPIO configurations . . . . .	153
8.2	GPIO registers . . . . .	157
8.2.1	Port configuration register low (GPIOx_CRL) (x=A..G) . . . . .	157
8.2.2	Port configuration register high (GPIOx_CRH) (x=A..G) . . . . .	158
8.2.3	Port input data register (GPIOx_IDR) (x=A..G) . . . . .	158
8.2.4	Port output data register (GPIOx_ODR) (x=A..G) . . . . .	159
8.2.5	Port bit set/reset register (GPIOx_BSRR) (x=A..G) . . . . .	159
8.2.6	Port bit reset register (GPIOx_BRR) (x=A..G) . . . . .	160
8.2.7	Port configuration lock register (GPIOx_LCKR) (x=A..G) . . . . .	160
8.3	Alternate function I/O and debug configuration (AFIO) . . . . .	161
8.3.1	Using OSC32_IN/OSC32_OUT pins as GPIO ports PC14/PC15 . . . . .	161
8.3.2	Using OSC_IN/OSC_OUT pins as GPIO ports PD0/PD1 . . . . .	161
8.3.3	CAN1 alternate function remapping . . . . .	162
8.3.4	CAN2 alternate function remapping . . . . .	162

8.3.5	JTAG/SWD alternate function remapping	162
8.3.6	ADC alternate function remapping	163
8.3.7	Timer alternate function remapping	164
8.3.8	USART alternate function remapping	166
8.3.9	I2C1 alternate function remapping	167
8.3.10	SPI1 alternate function remapping	167
8.3.11	SPI3/I2S3 alternate function remapping	167
8.3.12	Ethernet alternate function remapping	167
8.4	AFIO registers	168
8.4.1	Event control register (AFIO_EVCR)	169
8.4.2	AF remap and debug I/O configuration register (AFIO_MAPR)	170
8.4.3	External interrupt configuration register 1 (AFIO_EXTICR1)	176
8.4.4	External interrupt configuration register 2 (AFIO_EXTICR2)	176
8.4.5	External interrupt configuration register 3 (AFIO_EXTICR3)	177
8.4.6	External interrupt configuration register 4 (AFIO_EXTICR4)	177
8.4.7	AF remap and debug I/O configuration register2 (AFIO_MAPR2)	178
8.5	GPIO and AFIO register maps	179
<b>9</b>	<b>Interrupts and events</b>	<b>181</b>
9.1	Nested vectored interrupt controller (NVIC)	181
9.1.1	SysTick calibration value register	181
9.1.2	Interrupt and exception vectors	181
9.2	External interrupt/event controller (EXTI)	189
9.2.1	Main features	189
9.2.2	Block diagram	189
9.2.3	Wakeup event management	190
9.2.4	Functional description	190
9.2.5	External interrupt/event line mapping	191
9.3	EXTI registers	193
9.3.1	Interrupt mask register (EXTI_IMR)	193
9.3.2	Event mask register (EXTI_EMR)	193
9.3.3	Rising trigger selection register (EXTI_RTSR)	194
9.3.4	Falling trigger selection register (EXTI_FTSR)	194
9.3.5	Software interrupt event register (EXTI_SWIER)	195
9.3.6	Pending register (EXTI_PR)	195
9.3.7	EXTI register map	196

<b>10</b>	<b>DMA controller (DMA)</b> .....	<b>197</b>
10.1	DMA introduction .....	197
10.2	DMA main features .....	197
10.3	DMA functional description .....	199
10.3.1	DMA transactions .....	199
10.3.2	Arbiter .....	200
10.3.3	DMA channels .....	200
10.3.4	Programmable data width, data alignment and endians .....	202
10.3.5	Error management .....	203
10.3.6	Interrupts .....	203
10.3.7	DMA request mapping .....	204
10.4	DMA registers .....	207
10.4.1	DMA interrupt status register (DMA_ISR) .....	207
10.4.2	DMA interrupt flag clear register (DMA_IFCR) .....	208
10.4.3	DMA channel x configuration register (DMA_CCRx) (x = 1..7, where x = channel number) .....	209
10.4.4	DMA channel x number of data register (DMA_CNDTRx) (x = 1..7), where x = channel number) .....	210
10.4.5	DMA channel x peripheral address register (DMA_CPARx) (x = 1..7), where x = channel number) .....	211
10.4.6	DMA channel x memory address register (DMA_CMARx) (x = 1..7), where x = channel number) .....	211
10.4.7	DMA register map .....	212
<b>11</b>	<b>Analog-to-digital converter (ADC)</b> .....	<b>214</b>
11.1	ADC introduction .....	214
11.2	ADC main features .....	215
11.3	ADC functional description .....	215
11.3.1	ADC on-off control .....	217
11.3.2	ADC clock .....	217
11.3.3	Channel selection .....	217
11.3.4	Single conversion mode .....	218
11.3.5	Continuous conversion mode .....	218
11.3.6	Timing diagram .....	218
11.3.7	Analog watchdog .....	219
11.3.8	Scan mode .....	220
11.3.9	Injected channel management .....	220

- 11.3.10 Discontinuous mode ..... 221
- 11.4 Calibration ..... 222
- 11.5 Data alignment ..... 222
- 11.6 Channel-by-channel programmable sample time ..... 223
- 11.7 Conversion on external trigger ..... 223
- 11.8 DMA request ..... 225
- 11.9 Dual ADC mode ..... 226
  - 11.9.1 Injected simultaneous mode ..... 228
  - 11.9.2 Regular simultaneous mode ..... 228
  - 11.9.3 Fast interleaved mode ..... 229
  - 11.9.4 Slow interleaved mode ..... 229
  - 11.9.5 Alternate trigger mode ..... 230
  - 11.9.6 Independent mode ..... 231
  - 11.9.7 Combined regular/injected simultaneous mode ..... 231
  - 11.9.8 Combined regular simultaneous + alternate trigger mode ..... 231
  - 11.9.9 Combined injected simultaneous + interleaved ..... 232
- 11.10 Temperature sensor ..... 233
- 11.11 ADC interrupts ..... 234
- 11.12 ADC registers ..... 235
  - 11.12.1 ADC status register (ADC\_SR) ..... 235
  - 11.12.2 ADC control register 1 (ADC\_CR1) ..... 236
  - 11.12.3 ADC control register 2 (ADC\_CR2) ..... 238
  - 11.12.4 ADC sample time register 1 (ADC\_SMPR1) ..... 241
  - 11.12.5 ADC sample time register 2 (ADC\_SMPR2) ..... 242
  - 11.12.6 ADC injected channel data offset register x (ADC\_JOFRx)(x=1..4) .. 242
  - 11.12.7 ADC watchdog high threshold register (ADC\_HTR) ..... 243
  - 11.12.8 ADC watchdog low threshold register (ADC\_LTR) ..... 243
  - 11.12.9 ADC regular sequence register 1 (ADC\_SQR1) ..... 244
  - 11.12.10 ADC regular sequence register 2 (ADC\_SQR2) ..... 244
  - 11.12.11 ADC regular sequence register 3 (ADC\_SQR3) ..... 245
  - 11.12.12 ADC injected sequence register (ADC\_JSQR) ..... 246
  - 11.12.13 ADC injected data register x (ADC\_JDRx) (x= 1..4) ..... 246
  - 11.12.14 ADC regular data register (ADC\_DR) ..... 247
  - 11.12.15 ADC register map ..... 247

**12 Digital-to-analog converter (DAC) ..... 249**



12.1	DAC introduction	249
12.2	DAC main features	249
12.3	DAC functional description	251
12.3.1	DAC channel enable	251
12.3.2	DAC output buffer enable	251
12.3.3	DAC data format	251
12.3.4	DAC conversion	252
12.3.5	DAC output voltage	253
12.3.6	DAC trigger selection	253
12.3.7	DMA request	254
12.3.8	Noise generation	254
12.3.9	Triangle-wave generation	255
12.4	Dual DAC channel conversion	256
12.4.1	Independent trigger without wave generation	256
12.4.2	Independent trigger with same LFSR generation	257
12.4.3	Independent trigger with different LFSR generation	257
12.4.4	Independent trigger with same triangle generation	257
12.4.5	Independent trigger with different triangle generation	258
12.4.6	Simultaneous software start	258
12.4.7	Simultaneous trigger without wave generation	258
12.4.8	Simultaneous trigger with same LFSR generation	259
12.4.9	Simultaneous trigger with different LFSR generation	259
12.4.10	Simultaneous trigger with same triangle generation	259
12.4.11	Simultaneous trigger with different triangle generation	260
12.5	DAC registers	260
12.5.1	DAC control register (DAC_CR)	260
12.5.2	DAC software trigger register (DAC_SWTRIGR)	263
12.5.3	DAC channel1 12-bit right-aligned data holding register (DAC_DHR12R1)	264
12.5.4	DAC channel1 12-bit left aligned data holding register (DAC_DHR12L1)	264
12.5.5	DAC channel1 8-bit right aligned data holding register (DAC_DHR8R1)	264
12.5.6	DAC channel2 12-bit right aligned data holding register (DAC_DHR12R2)	265
12.5.7	DAC channel2 12-bit left aligned data holding register (DAC_DHR12L2)	265

12.5.8	DAC channel2 8-bit right-aligned data holding register (DAC_DHR8R2) . . . . .	265
12.5.9	Dual DAC 12-bit right-aligned data holding register (DAC_DHR12RD) . . . . .	266
12.5.10	DUAL DAC 12-bit left aligned data holding register (DAC_DHR12LD) . . . . .	266
12.5.11	DUAL DAC 8-bit right aligned data holding register (DAC_DHR8RD) . . . . .	267
12.5.12	DAC channel1 data output register (DAC_DOR1) . . . . .	267
12.5.13	DAC channel2 data output register (DAC_DOR2) . . . . .	267
12.5.14	DAC register map . . . . .	268
<b>13</b>	<b>Advanced-control timers (TIM1&amp;TIM8) . . . . .</b>	<b>269</b>
13.1	TIM1&TIM8 introduction . . . . .	269
13.2	TIM1&TIM8 main features . . . . .	270
13.3	TIM1&TIM8 functional description . . . . .	272
13.3.1	Time-base unit . . . . .	272
13.3.2	Counter modes . . . . .	273
13.3.3	Repetition counter . . . . .	281
13.3.4	Clock selection . . . . .	283
13.3.5	Capture/compare channels . . . . .	285
13.3.6	Input capture mode . . . . .	287
13.3.7	PWM input mode . . . . .	288
13.3.8	Forced output mode . . . . .	289
13.3.9	Output compare mode . . . . .	290
13.3.10	PWM mode . . . . .	291
13.3.11	Complementary outputs and dead-time insertion . . . . .	294
13.3.12	Using the break function . . . . .	295
13.3.13	Clearing the OCxREF signal on an external event . . . . .	298
13.3.14	6-step PWM generation . . . . .	299
13.3.15	One-pulse mode . . . . .	300
13.3.16	Encoder interface mode . . . . .	301
13.3.17	Timer input XOR function . . . . .	304
13.3.18	Interfacing with Hall sensors . . . . .	304
13.3.19	TIMx and external trigger synchronization . . . . .	306
13.3.20	Timer synchronization . . . . .	309
13.3.21	Debug mode . . . . .	309
13.4	TIM1&TIM8 registers . . . . .	310

13.4.1	TIM1&TIM8 control register 1 (TIMx_CR1) .....	310
13.4.2	TIM1&TIM8 control register 2 (TIMx_CR2) .....	311
13.4.3	TIM1&TIM8 slave mode control register (TIMx_SMCR) .....	313
13.4.4	TIM1&TIM8 DMA/interrupt enable register (TIMx_DIER) .....	315
13.4.5	TIM1&TIM8 status register (TIMx_SR) .....	317
13.4.6	TIM1&TIM8 event generation register (TIMx_EGR) .....	318
13.4.7	TIM1&TIM8 capture/compare mode register 1 (TIMx_CCMR1) .....	320
13.4.8	TIM1&TIM8 capture/compare mode register 2 (TIMx_CCMR2) .....	323
13.4.9	TIM1&TIM8 capture/compare enable register (TIMx_CCER) .....	324
13.4.10	TIM1&TIM8 counter (TIMx_CNT) .....	327
13.4.11	TIM1&TIM8 prescaler (TIMx_PSC) .....	327
13.4.12	TIM1&TIM8 auto-reload register (TIMx_ARR) .....	327
13.4.13	TIM1&TIM8 repetition counter register (TIMx_RCR) .....	328
13.4.14	TIM1&TIM8 capture/compare register 1 (TIMx_CCR1) .....	328
13.4.15	TIM1&TIM8 capture/compare register 2 (TIMx_CCR2) .....	329
13.4.16	TIM1&TIM8 capture/compare register 3 (TIMx_CCR3) .....	329
13.4.17	TIM1&TIM8 capture/compare register 4 (TIMx_CCR4) .....	330
13.4.18	TIM1&TIM8 break and dead-time register (TIMx_BDTR) .....	330
13.4.19	TIM1&TIM8 DMA control register (TIMx_DCR) .....	332
13.4.20	TIM1&TIM8 DMA address for full transfer (TIMx_DMAR) .....	333
13.4.21	TIM1&TIM8 register map .....	333
<b>14</b>	<b>General-purpose timer (TIM2 to TIM5) .....</b>	<b>335</b>
14.1	TIM2 to TIM5 introduction .....	335
14.2	TIMx main features .....	336
14.3	TIMx functional description .....	337
14.3.1	Time-base unit .....	337
14.3.2	Counter modes .....	339
14.3.3	Clock selection .....	347
14.3.4	Capture/compare channels .....	350
14.3.5	Input capture mode .....	352
14.3.6	PWM input mode .....	353
14.3.7	Forced output mode .....	354
14.3.8	Output compare mode .....	354
14.3.9	PWM mode .....	355
14.3.10	One-pulse mode .....	358
14.3.11	Clearing the OCxREF signal on an external event .....	359

14.3.12	Encoder interface mode	360
14.3.13	Timer input XOR function	362
14.3.14	Timers and external trigger synchronization	362
14.3.15	Timer synchronization	365
14.3.16	Debug mode	370
<b>14.4</b>	<b>TIMx2 to TIM5 registers</b>	<b>371</b>
14.4.1	TIMx control register 1 (TIMx_CR1)	371
14.4.2	TIMx control register 2 (TIMx_CR2)	372
14.4.3	TIMx slave mode control register (TIMx_SMCR)	373
14.4.4	TIMx DMA/Interrupt enable register (TIMx_DIER)	376
14.4.5	TIMx status register (TIMx_SR)	377
14.4.6	TIMx event generation register (TIMx_EGR)	378
14.4.7	TIMx capture/compare mode register 1 (TIMx_CCMR1)	379
14.4.8	Capture/compare mode register 2 (TIMx_CCMR2)	383
14.4.9	TIMx capture/compare enable register (TIMx_CCER)	384
14.4.10	TIMx counter (TIMx_CNT)	385
14.4.11	TIMx prescaler (TIMx_PSC)	386
14.4.12	TIMx auto-reload register (TIMx_ARR)	386
14.4.13	TIMx capture/compare register 1 (TIMx_CCR1)	386
14.4.14	TIMx capture/compare register 2 (TIMx_CCR2)	387
14.4.15	TIMx capture/compare register 3 (TIMx_CCR3)	387
14.4.16	TIMx capture/compare register 4 (TIMx_CCR4)	388
14.4.17	TIMx DMA control register (TIMx_DCR)	388
14.4.18	TIMx DMA address for full transfer (TIMx_DMAR)	389
14.4.19	TIMx register map	389
<b>15</b>	<b>General-purpose timers (TIM9 to TIM14)</b>	<b>391</b>
15.1	TIMx introduction	391
15.2	General-purpose timers TIM9 and TIM12	392
15.3	General-purpose timers TIM10/TIM11 and TIM13/TIM14	393
15.4	TIMx functional description	394
15.4.1	Time-base unit	394
15.4.2	Counter modes	395
15.4.3	Clock selection	398
15.4.4	Capture/compare channels	400
15.4.5	Input capture mode	401
15.4.6	PWM input mode (only for TIM9/12)	402

15.4.7	Forced output mode	403
15.4.8	Output compare mode	404
15.4.9	PWM mode	405
15.4.10	One-pulse mode (only for TIM9/12)	407
15.4.11	TIM9/12 and external trigger synchronization	409
15.4.12	Timer synchronization (TIM9/12)	411
15.4.13	Debug mode	411
15.5	TIM9 and TIM12 registers	412
15.5.1	TIM9/12 control register 1 (TIMx_CR1)	412
15.5.2	TIM9/12 control register 2 (TIMx_CR2)	413
15.5.3	TIM9/12 slave mode control register (TIMx_SMCR)	414
15.5.4	TIM9/12 Interrupt enable register (TIMx_DIER)	415
15.5.5	TIM9/12 status register (TIMx_SR)	416
15.5.6	TIM9/12 event generation register (TIMx_EGR)	417
15.5.7	TIM9/12 capture/compare mode register 1 (TIMx_CCMR1)	418
15.5.8	TIM9/12 capture/compare enable register (TIMx_CCER)	421
15.5.9	TIM9/12 counter (TIMx_CNT)	422
15.5.10	TIM9/12 prescaler (TIMx_PSC)	422
15.5.11	TIM9/12 auto-reload register (TIMx_ARR)	422
15.5.12	TIM9/12 capture/compare register 1 (TIMx_CCR1)	423
15.5.13	TIM9/12 capture/compare register 2 (TIMx_CCR2)	423
15.5.14	TIM9/12 register map	424
15.6	TIM10/11 and TIM13/14 registers	424
15.6.1	TIM10/11 and TIM13/14 control register 1 (TIMx_CR1)	424
15.6.2	TIMx control register 2 (TIMx_CR2)	425
15.6.3	TIM10/11 and TIM13/14 DMA/Interrupt enable register (TIMx_DIER)	426
15.6.4	TIM10/11 and TIM13/14 status register (TIMx_SR)	426
15.6.5	TIM10/11 and TIM13/14 event generation register (TIMx_EGR)	427
15.6.6	TIM10/11 and TIM13/14 capture/compare mode register 1 (TIMx_CCMR1)	428
15.6.7	TIM10/11 and TIM13/14 capture/compare enable register (TIMx_CCER)	431
15.6.8	TIM10/11 and TIM13/14 counter (TIMx_CNT)	432
15.6.9	TIM10/11 and TIM13/14 prescaler (TIMx_PSC)	432
15.6.10	TIM10/11 and TIM13/14 auto-reload register (TIMx_ARR)	432
15.6.11	TIM10/11 and TIM13/14 capture/compare register 1 (TIMx_CCR1)	433
15.6.12	TIM10/11/13/14 register map	433

<b>16</b>	<b>Basic timers (TIM6&amp;TIM7)</b> .....	<b>435</b>
16.1	TIM6&TIM7 introduction .....	435
16.2	TIM6&TIM7 main features .....	435
16.3	TIM6&TIM7 functional description .....	436
16.3.1	Time-base unit .....	436
16.3.2	Counting mode .....	438
16.3.3	Clock source .....	440
16.3.4	Debug mode .....	441
16.4	TIM6&TIM7 registers .....	441
16.4.1	TIM6&TIM7 control register 1 (TIMx_CR1) .....	441
16.4.2	TIM6&TIM7 control register 2 (TIMx_CR2) .....	443
16.4.3	TIM6&TIM7 DMA/Interrupt enable register (TIMx_DIER) .....	443
16.4.4	TIM6&TIM7 status register (TIMx_SR) .....	444
16.4.5	TIM6&TIM7 event generation register (TIMx_EGR) .....	444
16.4.6	TIM6&TIM7 counter (TIMx_CNT) .....	444
16.4.7	TIM6&TIM7 prescaler (TIMx_PSC) .....	445
16.4.8	TIM6&TIM7 auto-reload register (TIMx_ARR) .....	445
16.4.9	TIM6&TIM7 register map .....	446
<b>17</b>	<b>Real-time clock (RTC)</b> .....	<b>447</b>
17.1	RTC introduction .....	447
17.2	RTC main features .....	448
17.3	RTC functional description .....	448
17.3.1	Overview .....	448
17.3.2	Resetting RTC registers .....	449
17.3.3	Reading RTC registers .....	449
17.3.4	Configuring RTC registers .....	450
17.3.5	RTC flag assertion .....	450
17.4	RTC registers .....	451
17.4.1	RTC control register high (RTC_CRH) .....	452
17.4.2	RTC control register low (RTC_CRL) .....	452
17.4.3	RTC prescaler load register (RTC_PRLH / RTC_PRL) .....	454
17.4.4	RTC prescaler divider register (RTC_DIVH / RTC_DIVL) .....	454
17.4.5	RTC counter register (RTC_CNTH / RTC_CNTL) .....	455
17.4.6	RTC alarm register high (RTC_ALRH / RTC_ALRL) .....	456
17.4.7	RTC register map .....	457

<b>18</b>	<b>Independent watchdog (IWDG)</b>	<b>458</b>
18.1	IWDG introduction	458
18.2	IWDG main features	458
18.3	IWDG functional description	458
18.3.1	Hardware watchdog	459
18.3.2	Register access protection	459
18.3.3	Debug mode	459
18.4	IWDG registers	460
18.4.1	Key register (IWDG_KR)	460
18.4.2	Prescaler register (IWDG_PR)	461
18.4.3	Reload register (IWDG_RLR)	462
18.4.4	Status register (IWDG_SR)	462
18.4.5	IWDG register map	463
<b>19</b>	<b>Window watchdog (WWDG)</b>	<b>464</b>
19.1	WWDG introduction	464
19.2	WWDG main features	464
19.3	WWDG functional description	464
19.4	How to program the watchdog timeout	466
19.5	Debug mode	466
19.6	WWDG registers	467
19.6.1	Control register (WWDG_CR)	467
19.6.2	Configuration register (WWDG_CFR)	467
19.6.3	Status register (WWDG_SR)	468
19.6.4	WWDG register map	468
<b>20</b>	<b>Flexible static memory controller (FSMC)</b>	<b>469</b>
20.1	FSMC main features	469
20.2	Block diagram	470
20.3	AHB interface	471
20.3.1	Supported memories and transactions	472
20.4	External device address mapping	473
20.4.1	NOR/PSRAM address mapping	473
20.4.2	NAND/PC Card address mapping	474
20.5	NOR Flash/PSRAM controller	475

20.5.1	External memory interface signals . . . . .	476
20.5.2	Supported memories and transactions . . . . .	477
20.5.3	General timing rules . . . . .	479
20.5.4	NOR Flash/PSRAM controller asynchronous transactions . . . . .	480
20.5.5	Synchronous burst transactions . . . . .	495
20.5.6	NOR/PSRAM controller registers . . . . .	502
20.6	NAND Flash/PC Card controller . . . . .	507
20.6.1	External memory interface signals . . . . .	508
20.6.2	NAND Flash / PC Card supported memories and transactions . . . . .	510
20.6.3	Timing diagrams for NAND and PC Card . . . . .	510
20.6.4	NAND Flash operations . . . . .	511
20.6.5	NAND Flash pre-wait functionality . . . . .	512
20.6.6	Error correction code computation ECC (NAND Flash) . . . . .	513
20.6.7	PC Card/CompactFlash operations . . . . .	513
20.6.8	NAND Flash/PC Card controller registers . . . . .	516
20.6.9	FSMC register map . . . . .	522
<b>21</b>	<b>Secure digital input/output interface (SDIO) . . . . .</b>	<b>524</b>
21.1	SDIO main features . . . . .	524
21.2	SDIO bus topology . . . . .	525
21.3	SDIO functional description . . . . .	527
21.3.1	SDIO adapter . . . . .	528
21.3.2	SDIO AHB interface . . . . .	538
21.4	Card functional description . . . . .	539
21.4.1	Card identification mode . . . . .	539
21.4.2	Card reset . . . . .	539
21.4.3	Operating voltage range validation . . . . .	539
21.4.4	Card identification process . . . . .	540
21.4.5	Block write . . . . .	541
21.4.6	Block read . . . . .	541
21.4.7	Stream access, stream write and stream read (MultiMediaCard only) . . . . .	542
21.4.8	Erase: group erase and sector erase . . . . .	543
21.4.9	Wide bus selection or deselection . . . . .	544
21.4.10	Protection management . . . . .	544
21.4.11	Card status register . . . . .	547
21.4.12	SD status register . . . . .	550
21.4.13	SD I/O mode . . . . .	554



21.4.14	Commands and responses	555
21.5	Response formats	558
21.5.1	R1 (normal response command)	559
21.5.2	R1b	559
21.5.3	R2 (CID, CSD register)	559
21.5.4	R3 (OCR register)	559
21.5.5	R4 (Fast I/O)	560
21.5.6	R4b	560
21.5.7	R5 (interrupt request)	561
21.5.8	R6	561
21.6	SDIO I/O card-specific operations	562
21.6.1	SDIO I/O read wait operation by SDIO_D2 signalling	562
21.6.2	SDIO read wait operation by stopping SDIO_CK	562
21.6.3	SDIO suspend/resume operation	563
21.6.4	SDIO interrupts	563
21.7	CE-ATA specific operations	563
21.7.1	Command completion signal disable	563
21.7.2	Command completion signal enable	563
21.7.3	CE-ATA interrupt	564
21.7.4	Aborting CMD61	564
21.8	HW flow control	564
21.9	SDIO registers	564
21.9.1	SDIO power control register (SDIO_POWER)	565
21.9.2	SDI clock control register (SDIO_CLKCR)	565
21.9.3	SDIO argument register (SDIO_ARG)	566
21.9.4	SDIO command register (SDIO_CMD)	567
21.9.5	SDIO command response register (SDIO_RESPCMD)	568
21.9.6	SDIO response 1..4 register (SDIO_RESPx)	568
21.9.7	SDIO data timer register (SDIO_DTIMER)	569
21.9.8	SDIO data length register (SDIO_DLEN)	569
21.9.9	SDIO data control register (SDIO_DCTRL)	570
21.9.10	SDIO data counter register (SDIO_DCOUNT)	571
21.9.11	SDIO status register (SDIO_STA)	572
21.9.12	SDIO interrupt clear register (SDIO_ICR)	573
21.9.13	SDIO mask register (SDIO_MASK)	575
21.9.14	SDIO FIFO counter register (SDIO_FIFOCNT)	577

	21.9.15	SDIO data FIFO register (SDIO_FIFO) .....	578
	21.9.16	SDIO register map .....	578
<b>22</b>		<b>Universal serial bus full-speed device interface (USB) .....</b>	<b>580</b>
	22.1	USB introduction .....	580
	22.2	USB main features .....	580
	22.3	USB functional description .....	580
	22.3.1	Description of USB blocks .....	582
	22.4	Programming considerations .....	583
	22.4.1	Generic USB device programming .....	583
	22.4.2	System and power-on reset .....	584
	22.4.3	Double-buffered endpoints .....	589
	22.4.4	Isochronous transfers .....	591
	22.4.5	Suspend/Resume events .....	592
	22.5	USB registers .....	594
	22.5.1	Common registers .....	594
	22.5.2	Endpoint-specific registers .....	600
	22.5.3	Buffer descriptor table .....	604
	22.5.4	USB register map .....	608
<b>23</b>		<b>Controller area network (bxCAN) .....</b>	<b>610</b>
	23.1	bxCAN introduction .....	610
	23.2	bxCAN main features .....	610
	23.3	bxCAN general description .....	611
	23.3.1	CAN 2.0B active core .....	612
	23.3.2	Control, status and configuration registers .....	612
	23.3.3	Tx mailboxes .....	612
	23.3.4	Acceptance filters .....	612
	23.4	bxCAN operating modes .....	613
	23.4.1	Initialization mode .....	614
	23.4.2	Normal mode .....	614
	23.4.3	Sleep mode (low power) .....	614
	23.5	Test mode .....	615
	23.5.1	Silent mode .....	615
	23.5.2	Loop back mode .....	616
	23.5.3	Loop back combined with silent mode .....	616

23.6	STM32F10xxx in Debug mode	617
23.7	bxCAN functional description	617
23.7.1	Transmission handling	617
23.7.2	Time triggered communication mode	619
23.7.3	Reception handling	619
23.7.4	Identifier filtering	620
23.7.5	Message storage	624
23.7.6	Error management	626
23.7.7	Bit timing	626
23.8	bxCAN interrupts	628
23.9	CAN registers	630
23.9.1	Register access protection	630
23.9.2	CAN control and status registers	630
23.9.3	CAN mailbox registers	640
23.9.4	CAN filter registers	647
23.9.5	bxCAN register map	651
<b>24</b>	<b>Serial peripheral interface (SPI)</b>	<b>654</b>
24.1	SPI introduction	654
24.2	SPI and I <sup>2</sup> S main features	655
24.2.1	SPI features	655
24.2.2	I <sup>2</sup> S features	656
24.3	SPI functional description	657
24.3.1	General description	657
24.3.2	Configuring the SPI in slave mode	660
24.3.3	Configuring the SPI in master mode	661
24.3.4	Configuring the SPI for Simplex communication	662
24.3.5	Data transmission and reception procedures	663
24.3.6	CRC calculation	669
24.3.7	Status flags	670
24.3.8	Disabling the SPI	671
24.3.9	SPI communication using DMA (direct memory addressing)	672
24.3.10	Error flags	674
24.3.11	SPI interrupts	675
24.4	I <sup>2</sup> S functional description	675
24.4.1	I <sup>2</sup> S general description	675

24.4.2	Supported audio protocols	677
24.4.3	Clock generator	684
24.4.4	I <sup>2</sup> S master mode	687
24.4.5	I <sup>2</sup> S slave mode	689
24.4.6	Status flags	691
24.4.7	Error flags	692
24.4.8	I <sup>2</sup> S interrupts	692
24.4.9	DMA features	692
24.5	SPI and I <sup>2</sup> S registers	692
24.5.1	SPI control register 1 (SPI_CR1) (not used in I <sup>2</sup> S mode)	693
24.5.2	SPI control register 2 (SPI_CR2)	695
24.5.3	SPI status register (SPI_SR)	695
24.5.4	SPI data register (SPI_DR)	697
24.5.5	SPI CRC polynomial register (SPI_CRCPR) (not used in I <sup>2</sup> S mode)	697
24.5.6	SPI Rx CRC register (SPI_RXCRCR) (not used in I <sup>2</sup> S mode)	698
24.5.7	SPI Tx CRC register (SPI_TXCRCR) (not used in I <sup>2</sup> S mode)	698
24.5.8	SPI_I <sup>2</sup> S configuration register (SPI_I2SCFGR)	699
24.5.9	SPI_I <sup>2</sup> S prescaler register (SPI_I2SPR)	700
24.5.10	SPI register map	701
<b>25</b>	<b>Inter-integrated circuit (I<sup>2</sup>C) interface</b>	<b>702</b>
25.1	I <sup>2</sup> C introduction	702
25.2	I <sup>2</sup> C main features	702
25.3	I <sup>2</sup> C functional description	703
25.3.1	Mode selection	703
25.3.2	I2C slave mode	705
25.3.3	I2C master mode	707
25.3.4	Error conditions	714
25.3.5	SDA/SCL line control	715
25.3.6	SMBus	716
25.3.7	DMA requests	718
25.3.8	Packet error checking	719
25.4	I <sup>2</sup> C interrupts	720
25.5	I <sup>2</sup> C debug mode	722
25.6	I <sup>2</sup> C registers	722
25.6.1	Control register 1 (I2C_CR1)	722

25.6.2	Control register 2 (I2C_CR2) . . . . .	724
25.6.3	Own address register 1 (I2C_OAR1) . . . . .	725
25.6.4	Own address register 2 (I2C_OAR2) . . . . .	726
25.6.5	Data register (I2C_DR) . . . . .	726
25.6.6	Status register 1 (I2C_SR1) . . . . .	727
25.6.7	Status register 2 (I2C_SR2) . . . . .	730
25.6.8	Clock control register (I2C_CCR) . . . . .	731
25.6.9	TRISE register (I2C_TRISE) . . . . .	732
25.6.10	I2C register map . . . . .	733
<b>26</b>	<b>Universal synchronous asynchronous receiver transmitter (USART) . . . . .</b>	<b>734</b>
26.1	USART introduction . . . . .	734
26.2	USART main features . . . . .	735
26.3	USART functional description . . . . .	736
26.3.1	USART character description . . . . .	739
26.3.2	Transmitter . . . . .	740
26.3.3	Receiver . . . . .	743
26.3.4	Fractional baud rate generation . . . . .	747
26.3.5	USART receiver's tolerance to clock deviation . . . . .	748
26.3.6	Multiprocessor communication . . . . .	749
26.3.7	Parity control . . . . .	750
26.3.8	LIN (local interconnection network) mode . . . . .	751
26.3.9	USART synchronous mode . . . . .	754
26.3.10	Single-wire half-duplex communication . . . . .	756
26.3.11	Smartcard . . . . .	757
26.3.12	IrDA SIR ENDEC block . . . . .	759
26.3.13	Continuous communication using DMA . . . . .	761
26.3.14	Hardware flow control . . . . .	763
26.4	USART interrupts . . . . .	765
26.5	USART mode configuration . . . . .	766
26.6	USART registers . . . . .	766
26.6.1	Status register (USART_SR) . . . . .	766
26.6.2	Data register (USART_DR) . . . . .	768
26.6.3	Baud rate register (USART_BRR) . . . . .	769
26.6.4	Control register 1 (USART_CR1) . . . . .	770
26.6.5	Control register 2 (USART_CR2) . . . . .	772

26.6.6	Control register 3 (USART_CR3) .....	773
26.6.7	Guard time and prescaler register (USART_GTPR) .....	775
26.6.8	USART register map .....	776
<b>27</b>	<b>USB on-the-go full-speed (OTG_FS) .....</b>	<b>777</b>
27.1	OTG_FS introduction .....	777
27.2	OTG_FS main features .....	778
27.2.1	General features .....	778
27.2.2	Host-mode features .....	779
27.2.3	Peripheral-mode features .....	779
27.3	OTG_FS functional description .....	780
27.3.1	OTG full-speed core .....	780
27.3.2	Full-speed OTG PHY .....	780
27.4	OTG dual role device (DRD) .....	781
27.4.1	ID line detection .....	782
27.4.2	HNP dual role device .....	782
27.4.3	SRP dual role device .....	782
27.5	USB peripheral .....	783
27.5.1	SRP-capable peripheral .....	783
27.5.2	Peripheral states .....	784
27.5.3	Peripheral endpoints .....	785
27.6	USB host .....	787
27.6.1	SRP-capable host .....	788
27.6.2	USB host states .....	788
27.6.3	Host channels .....	789
27.6.4	Host scheduler .....	791
27.7	SOF trigger .....	792
27.7.1	Host SOFs .....	793
27.7.2	Peripheral SOFs .....	793
27.8	Power options .....	794
27.9	USB data FIFOs .....	794
27.10	Peripheral FIFO architecture .....	795
27.10.1	Peripheral Rx FIFO .....	795
27.10.2	Peripheral Tx FIFOs .....	796
27.11	Host FIFO architecture .....	796
27.11.1	Host Rx FIFO .....	796

27.11.2	Host Tx FIFOs	797
27.12	FIFO RAM allocation	797
27.12.1	Device mode	797
27.12.2	Host mode	798
27.13	USB system performance	798
27.14	OTG_FS interrupts	799
27.15	OTG_FS control and status registers	801
27.15.1	CSR memory map	801
27.15.2	OTG_FS global registers	806
27.15.3	Host-mode registers	827
27.15.4	Device-mode registers	838
27.15.5	OTG_FS power and clock gating control register (OTG_FS_PCGCCTL)	860
27.15.6	OTG_FS register map	861
27.16	OTG_FS programming model	867
27.16.1	Core initialization	867
27.16.2	Host initialization	869
27.16.3	Device initialization	869
27.16.4	Host programming model	870
27.16.5	Device programming model	886
27.16.6	Operational model	888
27.16.7	Worst case response time	905
27.16.8	OTG programming model	906
<b>28</b>	<b>Ethernet (ETH): media access control (MAC) with DMA controller</b>	<b>912</b>
28.1	Ethernet introduction	912
28.2	Ethernet main features	912
28.2.1	MAC core features	913
28.2.2	DMA features	914
28.2.3	PTP features	914
28.3	Ethernet pins	915
28.4	Ethernet functional description: SMI, MII and RMII	916
28.4.1	Station management interface: SMI	916
28.4.2	Media-independent interface: MII	919
28.4.3	Reduced media-independent interface: RMII	922
28.4.4	MII/RMII selection	923

28.5	Ethernet functional description: MAC 802.3	924
28.5.1	MAC 802.3 frame format	924
28.5.2	MAC frame transmission	928
28.5.3	MAC frame reception	935
28.5.4	MAC interrupts	940
28.5.5	MAC filtering	940
28.5.6	MAC loopback mode	943
28.5.7	MAC management counters: MMC	943
28.5.8	Power management: PMT	944
28.5.9	Precision time protocol (IEEE1588 PTP)	947
28.6	Ethernet functional description: DMA controller operation	953
28.6.1	Initialization of a transfer using DMA	954
28.6.2	Host bus burst access	954
28.6.3	Host data buffer alignment	955
28.6.4	Buffer size calculations	955
28.6.5	DMA arbiter	956
28.6.6	<b>Error response to DMA</b>	<b>956</b>
28.6.7	Tx DMA configuration	956
28.6.8	Rx DMA configuration	970
28.6.9	DMA interrupts	979
28.7	Ethernet interrupts	980
28.8	Ethernet register descriptions	981
28.8.1	MAC register description	981
28.8.2	MMC register description	998
28.8.3	IEEE 1588 time stamp registers	1003
28.8.4	DMA register description	1007
28.8.5	Ethernet register maps	1021
<b>29</b>	<b>Device electronic signature</b>	<b>1024</b>
29.1	Memory size registers	1024
29.1.1	Flash size register	1024
29.2	Unique device ID register (96 bits)	1025
<b>30</b>	<b>Debug support (DBG)</b>	<b>1027</b>
30.1	Overview	1027
30.2	Reference ARM documentation	1029



30.3	SWJ debug port (serial wire and JTAG) . . . . .	1029
30.3.1	Mechanism to select the JTAG-DP or the SW-DP . . . . .	1029
30.4	Pinout and debug port pins . . . . .	1030
30.4.1	SWJ debug port pins . . . . .	1030
30.4.2	Flexible SWJ-DP pin assignment . . . . .	1030
30.4.3	Internal pull-up and pull-down on JTAG pins . . . . .	1031
30.4.4	Using serial wire and releasing the unused debug pins as GPIOs . .	1032
30.5	STM32F10xxx JTAG TAP connection . . . . .	1032
30.6	ID codes and locking mechanism . . . . .	1033
30.6.1	MCU device ID code . . . . .	1033
30.6.2	Boundary scan TAP . . . . .	1035
30.6.3	Cortex-M3 TAP . . . . .	1035
30.6.4	Cortex-M3 JEDEC-106 ID code . . . . .	1035
30.7	JTAG debug port . . . . .	1035
30.8	SW debug port . . . . .	1037
30.8.1	SW protocol introduction . . . . .	1037
30.8.2	SW protocol sequence . . . . .	1037
30.8.3	SW-DP state machine (Reset, idle states, ID code) . . . . .	1038
30.8.4	DP and AP read/write accesses . . . . .	1039
30.8.5	SW-DP registers . . . . .	1039
30.8.6	SW-AP registers . . . . .	1040
30.9	AHB-AP (AHB access port) - valid for both JTAG-DP or SW-DP . . . . .	1040
30.10	Core debug . . . . .	1041
30.11	Capability of the debugger host to connect under system reset . . . . .	1042
30.12	FPB (Flash patch breakpoint) . . . . .	1042
30.13	DWT (data watchpoint trigger) . . . . .	1043
30.14	ITM (instrumentation trace macrocell) . . . . .	1043
30.14.1	General description . . . . .	1043
30.14.2	Time stamp packets, synchronization and overflow packets . . . . .	1043
30.15	ETM (Embedded Trace Macrocell) . . . . .	1045
30.15.1	General description . . . . .	1045
30.15.2	Signal protocol, packet types . . . . .	1045
30.15.3	Main ETM registers . . . . .	1045
30.15.4	Configuration example . . . . .	1046
30.16	MCU debug component (DBGMCU) . . . . .	1046

---

30.16.1	Debug support for low-power modes .....	1046
30.16.2	Debug support for timers, watchdog, bxCAN and I <sup>2</sup> C .....	1047
30.16.3	Debug MCU configuration register .....	1047
30.17	TPIU (trace port interface unit) .....	1049
30.17.1	Introduction .....	1049
30.17.2	TRACE pin assignment .....	1050
30.17.3	TPUI formatter .....	1052
30.17.4	TPUI frame synchronization packets .....	1052
30.17.5	Transmission of the synchronization frame packet .....	1052
30.17.6	Synchronous mode .....	1053
30.17.7	Asynchronous mode .....	1053
30.17.8	TRACECLKIN connection inside the STM32F10xxx .....	1053
30.17.9	TPIU registers .....	1053
30.17.10	Example of configuration .....	1054
30.18	DBG register map .....	1055
<b>31</b>	<b>Revision history .....</b>	<b>1056</b>

## List of tables

Table 1.	Register boundary addresses . . . . .	44
Table 2.	Flash module organization (low-density devices) . . . . .	48
Table 3.	Flash module organization (medium-density devices) . . . . .	49
Table 4.	Flash module organization (high-density devices) . . . . .	50
Table 5.	Flash module organization (connectivity line devices) . . . . .	51
Table 6.	XL-density Flash module organization . . . . .	51
Table 7.	Boot modes . . . . .	54
Table 8.	CRC calculation unit register map and reset values . . . . .	58
Table 9.	Low-power mode summary . . . . .	64
Table 10.	Sleep-now . . . . .	66
Table 11.	Sleep-on-exit . . . . .	66
Table 12.	Stop mode . . . . .	67
Table 13.	Standby mode . . . . .	68
Table 14.	PWR register map and reset values . . . . .	72
Table 15.	BKP register map and reset values . . . . .	77
Table 16.	RCC register map and reset values . . . . .	111
Table 17.	RCC register map and reset values . . . . .	144
Table 18.	Port bit configuration table . . . . .	148
Table 19.	Output MODE bits . . . . .	148
Table 20.	Advanced timers TIM1/TIM8 . . . . .	153
Table 21.	General-purpose timers TIM2/3/4/5 . . . . .	153
Table 22.	USARTs . . . . .	153
Table 23.	SPI . . . . .	153
Table 24.	I2S . . . . .	154
Table 25.	I2C . . . . .	154
Table 26.	BxCAN . . . . .	154
Table 27.	USB . . . . .	154
Table 28.	OTG_FS pin configuration . . . . .	155
Table 29.	SDIO . . . . .	155
Table 30.	FSMC . . . . .	156
Table 31.	Other IOs . . . . .	156
Table 32.	CAN1 alternate function remapping . . . . .	162
Table 33.	CAN2 alternate function remapping . . . . .	162
Table 34.	Debug interface signals . . . . .	162
Table 35.	Debug port mapping . . . . .	163
Table 36.	ADC1 external trigger injected conversion alternate function remapping . . . . .	163
Table 37.	ADC1 external trigger regular conversion alternate function remapping . . . . .	163
Table 38.	ADC2 external trigger injected conversion alternate function remapping . . . . .	163
Table 39.	ADC2 external trigger regular conversion alternate function remapping . . . . .	164
Table 40.	TIM5 alternate function remapping . . . . .	164
Table 41.	TIM4 alternate function remapping . . . . .	164
Table 42.	TIM3 alternate function remapping . . . . .	164
Table 43.	TIM2 alternate function remapping . . . . .	165
Table 44.	TIM1 alternate function remapping . . . . .	165
Table 45.	TIM9 remapping . . . . .	165
Table 46.	TIM10 remapping . . . . .	165
Table 47.	TIM11 remapping . . . . .	166
Table 48.	TIM13 remapping . . . . .	166

Table 49.	TIM14 remapping . . . . .	166
Table 50.	USART3 remapping . . . . .	166
Table 51.	USART2 remapping . . . . .	166
Table 52.	USART1 remapping . . . . .	167
Table 53.	I2C1 remapping . . . . .	167
Table 54.	SPI1 remapping . . . . .	167
Table 55.	SPI3/I2S3 remapping . . . . .	167
Table 56.	ETH remapping . . . . .	168
Table 57.	GPIO register map and reset values . . . . .	179
Table 58.	AFIO register map and reset values . . . . .	179
Table 59.	Vector table for connectivity line devices . . . . .	181
Table 60.	Vector table for XL-density devices . . . . .	184
Table 61.	Vector table for other STM32F10xxx devices . . . . .	187
Table 62.	External interrupt/event controller register map and reset values . . . . .	196
Table 63.	Programmable data width & endian behavior (when bits PINC = MINC = 1) . . . . .	202
Table 64.	DMA interrupt requests . . . . .	203
Table 65.	Summary of DMA1 requests for each channel . . . . .	205
Table 66.	Summary of DMA2 requests for each channel . . . . .	206
Table 67.	DMA register map and reset values . . . . .	212
Table 68.	ADC pins . . . . .	217
Table 69.	Analog watchdog channel selection . . . . .	219
Table 70.	External trigger for regular channels for ADC1 and ADC2 . . . . .	224
Table 71.	External trigger for injected channels for ADC1 and ADC2 . . . . .	224
Table 72.	External trigger for regular channels for ADC3 . . . . .	225
Table 73.	External trigger for injected channels for ADC3 . . . . .	225
Table 74.	ADC interrupts . . . . .	234
Table 75.	ADC register map and reset values . . . . .	247
Table 76.	DAC pins . . . . .	250
Table 77.	External triggers . . . . .	253
Table 78.	DAC register map . . . . .	268
Table 79.	Counting direction versus encoder signals . . . . .	302
Table 80.	TIMx Internal trigger connection . . . . .	315
Table 81.	Output control bits for complementary OCx and OCxN channels with break feature . . . . .	326
Table 82.	TIM1&TIM8 register map and reset values . . . . .	333
Table 83.	Counting direction versus encoder signals . . . . .	361
Table 84.	TIMx Internal trigger connection . . . . .	375
Table 85.	Output control bit for standard OCx channels . . . . .	385
Table 86.	TIMx register map and reset values . . . . .	389
Table 87.	TIMx internal trigger connection . . . . .	415
Table 88.	Output control bit for standard OCx channels . . . . .	422
Table 89.	TIM9/12 register map and reset values . . . . .	424
Table 90.	Output control bit for standard OCx channels . . . . .	431
Table 91.	TIM10/11/13/14 register map and reset values . . . . .	433
Table 92.	TIM6&TIM7 register map and reset values . . . . .	446
Table 93.	RTC register map and reset values . . . . .	457
Table 94.	Min/max IWDG timeout period at 40 kHz (LSI) . . . . .	459
Table 95.	IWDG register map and reset values . . . . .	463
Table 96.	WWDG register map and reset values . . . . .	468
Table 97.	NOR/PSRAM bank selection . . . . .	473
Table 98.	External memory address . . . . .	474
Table 99.	Memory mapping and timing registers . . . . .	474

Table 100.	NAND bank selections	474
Table 101.	Programmable NOR/PSRAM access parameters	475
Table 102.	Nonmuxed I/O NOR Flash	476
Table 103.	Muxed I/O NOR Flash	476
Table 104.	Non muxed I/Os PSRAM/SRAM	477
Table 105.	NOR Flash/PSRAM supported memories and transactions	478
Table 106.	FSMC_BCRx bit fields	481
Table 107.	FSMC_BTRx bit fields	482
Table 108.	FSMC_BCRx bit fields	483
Table 109.	FSMC_BTRx bit fields	484
Table 110.	FSMC_BWTRx bit fields	484
Table 111.	FSMC_BCRx bit fields	486
Table 112.	FSMC_BTRx bit fields	487
Table 113.	FSMC_BWTRx bit fields	487
Table 114.	FSMC_BCRx bit fields	489
Table 115.	FSMC_BTRx bit fields	489
Table 116.	FSMC_BWTRx bit fields	489
Table 117.	FSMC_BCRx bit fields	491
Table 118.	FSMC_BTRx bit fields	491
Table 119.	FSMC_BWTRx bit fields	491
Table 120.	FSMC_BCRx bit fields	493
Table 121.	FSMC_BTRx bit fields	493
Table 122.	FSMC_BCRx bit fields	498
Table 123.	FSMC_BTRx bit fields	499
Table 124.	FSMC_BCRx bit fields	501
Table 125.	FSMC_BTRx bit fields	501
Table 126.	Programmable NAND/PC Card access parameters	508
Table 127.	8-bit NAND Flash	508
Table 128.	16-bit NAND Flash	509
Table 129.	16-bit PC Card	509
Table 130.	Supported memories and transactions	510
Table 131.	16-bit PC-Card signals and access type	514
Table 132.	ECC result relevant bits	521
Table 133.	FSMC register map	522
Table 134.	SDIO I/O definitions	528
Table 135.	Command format	532
Table 136.	Short response format	533
Table 137.	Long response format	533
Table 138.	Command path status flags	533
Table 139.	Data token format	536
Table 140.	Transmit FIFO status flags	537
Table 141.	Receive FIFO status flags	538
Table 142.	Card status	548
Table 143.	SD status	550
Table 144.	Speed class code field	552
Table 145.	Performance move field	552
Table 146.	AU_SIZE field	552
Table 147.	Maximum AU size	553
Table 148.	Erase size field	553
Table 149.	Erase timeout field	553
Table 150.	Erase offset field	554
Table 151.	Block-oriented write commands	556

Table 152.	Block-oriented write protection commands	557
Table 153.	Erase commands	557
Table 154.	I/O mode commands	557
Table 155.	Lock card	558
Table 156.	Application-specific commands	558
Table 157.	R1 response	559
Table 158.	R2 response	559
Table 159.	R3 response	560
Table 160.	R4 response	560
Table 161.	R4b response	560
Table 162.	R5 response	561
Table 163.	R6 response	561
Table 164.	Response type and SDIO_RESPx registers	568
Table 165.	SDIO register map	578
Table 166.	Double-buffering buffer flag definition	590
Table 167.	Bulk double-buffering memory buffers usage	590
Table 168.	Isochronous memory buffers usage	592
Table 169.	Resume event detection	593
Table 170.	Reception status encoding	603
Table 171.	Endpoint type encoding	603
Table 172.	Endpoint kind meaning	604
Table 173.	Transmission status encoding	604
Table 174.	Definition of allocated buffer memory	607
Table 175.	USB register map and reset values	608
Table 176.	Transmit mailbox mapping	625
Table 177.	Receive mailbox mapping	625
Table 178.	bxCAN register map and reset values	651
Table 179.	SPI interrupt requests	675
Table 180.	Audio-frequency precision using standard 8 MHz HSE (high-density and XL-density devices only)	685
Table 181.	Audio-frequency precision using standard 25 MHz and PLL3 (connectivity line devices only)	686
Table 182.	Audio-frequency precision using standard 14.7456 MHz and PLL3 (connectivity line devices only)	686
Table 183.	I <sup>2</sup> S interrupt requests	692
Table 184.	SPI register map and reset values	701
Table 185.	SMBus vs. I2C	716
Table 186.	I2C Interrupt requests	720
Table 187.	I2C register map and reset values	733
Table 188.	Noise detection from sampled data	745
Table 189.	Error calculation for programmed baud rates	748
Table 190.	USART receiver 's tolerance when DIV_Fraction is 0	749
Table 191.	USART receiver's tolerance when DIV_Fraction is different from 0	749
Table 192.	Frame formats	751
Table 193.	USART interrupt requests	765
Table 194.	USART mode configuration	766
Table 195.	USART register map and reset values	776
Table 196.	Core global control and status registers (CSRs)	802
Table 197.	Host-mode control and status registers (CSRs)	803
Table 198.	Device-mode control and status registers	804
Table 199.	Data FIFO (DFIFO) access register map	806
Table 200.	Power and clock gating control and status registers	806

Table 201.	Minimum duration for soft disconnect . . . . .	840
Table 202.	OTG_FS register map and reset values . . . . .	861
Table 203.	Ethernet pin configuration . . . . .	915
Table 204.	Management frame format . . . . .	917
Table 205.	Clock range . . . . .	919
Table 206.	TX interface signal encoding . . . . .	921
Table 207.	RX interface signal encoding . . . . .	921
Table 208.	Frame statuses . . . . .	937
Table 209.	Destination address filtering table . . . . .	942
Table 210.	Source address filtering table . . . . .	943
Table 211.	Receive descriptor 0 . . . . .	975
Table 212.	Ethernet register map and reset values . . . . .	1021
Table 213.	SWJ debug port pins . . . . .	1030
Table 214.	Flexible SWJ-DP pin assignment . . . . .	1031
Table 215.	JTAG debug port data registers . . . . .	1035
Table 216.	32-bit debug port registers addressed through the shifted value A[3:2] . . . . .	1037
Table 217.	Packet request (8-bits) . . . . .	1038
Table 218.	ACK response (3 bits) . . . . .	1038
Table 219.	DATA transfer (33 bits) . . . . .	1038
Table 220.	SW-DP registers . . . . .	1039
Table 221.	Cortex-M3 AHB-AP registers . . . . .	1041
Table 222.	Core debug registers . . . . .	1041
Table 223.	Main ITM registers . . . . .	1044
Table 224.	Main ETM registers . . . . .	1046
Table 225.	Asynchronous TRACE pin assignment . . . . .	1050
Table 226.	Synchronous TRACE pin assignment . . . . .	1050
Table 227.	Flexible TRACE pin assignment . . . . .	1051
Table 228.	Important TPIU registers . . . . .	1054
Table 229.	DBG register map and reset values . . . . .	1055
Table 230.	Document revision history . . . . .	1056

## List of figures

Figure 1.	System architecture	41
Figure 2.	System architecture in connectivity line devices.	42
Figure 3.	CRC calculation unit block diagram	56
Figure 4.	Power supply overview	60
Figure 5.	Power on reset/power down reset waveform	62
Figure 6.	PVD thresholds.	63
Figure 7.	Simplified diagram of the reset circuit.	82
Figure 8.	Clock tree	84
Figure 9.	HSE/ LSE clock sources.	85
Figure 10.	Simplified diagram of the reset circuit.	113
Figure 11.	Clock tree	115
Figure 12.	HSE/ LSE clock sources.	117
Figure 13.	Basic structure of a standard I/O port bit	147
Figure 14.	Basic structure of a five-volt tolerant I/O port bit.	147
Figure 15.	Input floating/pull up/pull down configurations	150
Figure 16.	Output configuration	151
Figure 17.	Alternate function configuration	152
Figure 18.	High impedance-analog configuration	152
Figure 19.	ADC / DAC	155
Figure 20.	External interrupt/event controller block diagram	190
Figure 21.	External interrupt/event GPIO mapping	192
Figure 22.	DMA block diagram in connectivity line devices	198
Figure 23.	DMA block diagram in low-, medium- high- and XL-density devices	199
Figure 24.	DMA1 request mapping	204
Figure 25.	DMA2 request mapping	206
Figure 26.	Single ADC block diagram	216
Figure 27.	Timing diagram	219
Figure 28.	Analog watchdog guarded area	219
Figure 29.	Injected conversion latency	221
Figure 30.	Calibration timing diagram	222
Figure 31.	Right alignment of data	223
Figure 32.	Left alignment of data	223
Figure 33.	Dual ADC block diagram <sup>(1)</sup>	227
Figure 34.	Injected simultaneous mode on 4 channels	228
Figure 35.	Regular simultaneous mode on 16 channels	229
Figure 36.	Fast interleaved mode on 1 channel in continuous conversion mode	229
Figure 37.	Slow interleaved mode on 1 channel	230
Figure 38.	Alternate trigger: injected channel group of each ADC.	230
Figure 39.	Alternate trigger: 4 injected channels (each ADC) in discontinuous model	231
Figure 40.	Alternate + Regular simultaneous.	232
Figure 41.	Case of trigger occurring during injected conversion	232
Figure 42.	Interleaved single channel with injected sequence CH11, CH12.	232
Figure 43.	Temperature sensor and VREFINT channel block diagram	233
Figure 44.	DAC channel block diagram	250
Figure 45.	Data registers in single DAC channel mode.	252
Figure 46.	Data registers in dual DAC channel mode	252
Figure 47.	Timing diagram for conversion with trigger disabled TEN = 0	253
Figure 48.	DAC LFSR register calculation algorithm	254



Figure 49.	DAC conversion (SW trigger enabled) with LFSR wave generation. . . . .	255
Figure 50.	DAC triangle wave generation . . . . .	255
Figure 51.	DAC conversion (SW trigger enabled) with triangle wave generation . . . . .	256
Figure 52.	Advanced-control timer block diagram . . . . .	271
Figure 53.	Counter timing diagram with prescaler division change from 1 to 2 . . . . .	273
Figure 54.	Counter timing diagram with prescaler division change from 1 to 4 . . . . .	273
Figure 55.	Counter timing diagram, internal clock divided by 1 . . . . .	274
Figure 56.	Counter timing diagram, internal clock divided by 2 . . . . .	274
Figure 57.	Counter timing diagram, internal clock divided by 4 . . . . .	275
Figure 58.	Counter timing diagram, internal clock divided by N . . . . .	275
Figure 59.	Counter timing diagram, update event when ARPE=0 (TIMx_ARR not preloaded) . . . . .	275
Figure 60.	Counter timing diagram, update event when ARPE=1 (TIMx_ARR preloaded) . . . . .	276
Figure 61.	Counter timing diagram, internal clock divided by 1 . . . . .	277
Figure 62.	Counter timing diagram, internal clock divided by 2 . . . . .	277
Figure 63.	Counter timing diagram, internal clock divided by 4 . . . . .	277
Figure 64.	Counter timing diagram, internal clock divided by N . . . . .	278
Figure 65.	Counter timing diagram, update event when repetition counter is not used. . . . .	278
Figure 66.	Counter timing diagram, internal clock divided by 1, TIMx_ARR = 0x6 . . . . .	279
Figure 67.	Counter timing diagram, internal clock divided by 2 . . . . .	280
Figure 68.	Counter timing diagram, internal clock divided by 4, TIMx_ARR=0x36 . . . . .	280
Figure 69.	Counter timing diagram, internal clock divided by N . . . . .	280
Figure 70.	Counter timing diagram, update event with ARPE=1 (counter underflow) . . . . .	281
Figure 71.	Counter timing diagram, Update event with ARPE=1 (counter overflow) . . . . .	281
Figure 72.	Update rate examples depending on mode and TIMx_RCR register settings . . . . .	282
Figure 73.	Control circuit in normal mode, internal clock divided by 1 . . . . .	283
Figure 74.	TI2 external clock connection example. . . . .	283
Figure 75.	Control circuit in external clock mode 1 . . . . .	284
Figure 76.	External trigger input block . . . . .	284
Figure 77.	Control circuit in external clock mode 2 . . . . .	285
Figure 78.	Capture/compare channel (example: channel 1 input stage) . . . . .	286
Figure 79.	Capture/compare channel 1 main circuit . . . . .	286
Figure 80.	Output stage of capture/compare channel (channel 1 to 3) . . . . .	287
Figure 81.	Output stage of capture/compare channel (channel 4) . . . . .	287
Figure 82.	PWM input mode timing . . . . .	289
Figure 83.	Output compare mode, toggle on OC1. . . . .	291
Figure 84.	Edge-aligned PWM waveforms (ARR=8) . . . . .	292
Figure 85.	Center-aligned PWM waveforms (ARR=8) . . . . .	293
Figure 86.	Complementary output with dead-time insertion. . . . .	294
Figure 87.	Dead-time waveforms with delay greater than the negative pulse. . . . .	294
Figure 88.	Dead-time waveforms with delay greater than the positive pulse. . . . .	295
Figure 89.	Output behavior in response to a break. . . . .	297
Figure 90.	Clearing TIMx_OCxREF . . . . .	298
Figure 91.	6-step generation, COM example (OSSR=1) . . . . .	299
Figure 92.	Example of one pulse mode. . . . .	300
Figure 93.	Example of counter operation in encoder interface mode. . . . .	303
Figure 94.	Example of encoder interface mode with TI1FP1 polarity inverted. . . . .	303
Figure 95.	Example of hall sensor interface. . . . .	305
Figure 96.	Control circuit in reset mode . . . . .	306
Figure 97.	Control circuit in gated mode . . . . .	307
Figure 98.	Control circuit in trigger mode . . . . .	308
Figure 99.	Control circuit in external clock mode 2 + trigger mode . . . . .	309
Figure 100.	General-purpose timer block diagram . . . . .	337

Figure 101. Counter timing diagram with prescaler division change from 1 to 2 . . . . .	338
Figure 102. Counter timing diagram with prescaler division change from 1 to 4 . . . . .	339
Figure 103. Counter timing diagram, internal clock divided by 1 . . . . .	340
Figure 104. Counter timing diagram, internal clock divided by 2 . . . . .	340
Figure 105. Counter timing diagram, internal clock divided by 4 . . . . .	340
Figure 106. Counter timing diagram, internal clock divided by N . . . . .	341
Figure 107. Counter timing diagram, Update event when ARPE=0 (TIMx_ARR not preloaded). . . . .	341
Figure 108. Counter timing diagram, Update event when ARPE=1 (TIMx_ARR preloaded). . . . .	342
Figure 109. Counter timing diagram, internal clock divided by 1 . . . . .	343
Figure 110. Counter timing diagram, internal clock divided by 2 . . . . .	343
Figure 111. Counter timing diagram, internal clock divided by 4 . . . . .	343
Figure 112. Counter timing diagram, internal clock divided by N . . . . .	344
Figure 113. Counter timing diagram, Update event when repetition counter is not used . . . . .	344
Figure 114. Counter timing diagram, internal clock divided by 1, TIMx_ARR=0x6 . . . . .	345
Figure 115. Counter timing diagram, internal clock divided by 2 . . . . .	346
Figure 116. Counter timing diagram, internal clock divided by 4, TIMx_ARR=0x36 . . . . .	346
Figure 117. Counter timing diagram, internal clock divided by N . . . . .	346
Figure 118. Counter timing diagram, Update event with ARPE=1 (counter underflow). . . . .	347
Figure 119. Counter timing diagram, Update event with ARPE=1 (counter overflow). . . . .	347
Figure 120. Control circuit in normal mode, internal clock divided by 1 . . . . .	348
Figure 121. TI2 external clock connection example. . . . .	348
Figure 122. Control circuit in external clock mode 1 . . . . .	349
Figure 123. External trigger input block . . . . .	349
Figure 124. Control circuit in external clock mode 2 . . . . .	350
Figure 125. Capture/compare channel (example: channel 1 input stage) . . . . .	350
Figure 126. Capture/compare channel 1 main circuit . . . . .	351
Figure 127. Output stage of capture/compare channel (channel 1). . . . .	351
Figure 128. PWM input mode timing . . . . .	353
Figure 129. Output compare mode, toggle on OC1. . . . .	355
Figure 130. Edge-aligned PWM waveforms (ARR=8) . . . . .	356
Figure 131. Center-aligned PWM waveforms (ARR=8) . . . . .	357
Figure 132. Example of one-pulse mode. . . . .	358
Figure 133. Clearing TIMx_OCxREF . . . . .	360
Figure 134. Example of counter operation in encoder interface mode. . . . .	361
Figure 135. Example of encoder interface mode with IC1FP1 polarity inverted. . . . .	362
Figure 136. Control circuit in reset mode . . . . .	363
Figure 137. Control circuit in gated mode . . . . .	364
Figure 138. Control circuit in trigger mode. . . . .	364
Figure 139. Control circuit in external clock mode 2 + trigger mode . . . . .	365
Figure 140. Master/Slave timer example . . . . .	366
Figure 141. Gating timer 2 with OC1REF of timer 1 . . . . .	367
Figure 142. Gating timer 2 with Enable of timer 1 . . . . .	368
Figure 143. Triggering timer 2 with update of timer 1 . . . . .	368
Figure 144. Triggering timer 2 with Enable of timer 1 . . . . .	369
Figure 145. Triggering timer 1 and 2 with timer 1 TI1 input . . . . .	370
Figure 146. General-purpose timer block diagram (TIM9 and TIM12). . . . .	392
Figure 147. General-purpose timer block diagram (TIM10/11/13/14) . . . . .	393
Figure 148. Counter timing diagram with prescaler division change from 1 to 2 . . . . .	395
Figure 149. Counter timing diagram with prescaler division change from 1 to 4 . . . . .	395
Figure 150. Counter timing diagram, internal clock divided by 1 . . . . .	396
Figure 151. Counter timing diagram, internal clock divided by 2 . . . . .	396
Figure 152. Counter timing diagram, internal clock divided by 4 . . . . .	397

Figure 153. Counter timing diagram, internal clock divided by N. . . . .	397
Figure 154. Counter timing diagram, update event when ARPE=0 (TIMx_ARR not preloaded). . . . .	397
Figure 155. Counter timing diagram, update event when ARPE=1 (TIMx_ARR preloaded). . . . .	398
Figure 156. Control circuit in normal mode, internal clock divided by 1. . . . .	399
Figure 157. TI2 external clock connection example. . . . .	399
Figure 158. Control circuit in external clock mode 1. . . . .	400
Figure 159. Capture/compare channel (example: channel 1 input stage). . . . .	400
Figure 160. Capture/compare channel 1 main circuit. . . . .	401
Figure 161. Output stage of capture/compare channel (channel 1). . . . .	401
Figure 162. PWM input mode timing. . . . .	403
Figure 163. Output compare mode, toggle on OC1. . . . .	405
Figure 164. Edge-aligned PWM waveforms (ARR=8). . . . .	406
Figure 165. Example of one pulse mode. . . . .	407
Figure 166. Control circuit in reset mode. . . . .	409
Figure 167. Control circuit in gated mode. . . . .	410
Figure 168. Control circuit in trigger mode. . . . .	411
Figure 169. Basic timer block diagram. . . . .	436
Figure 170. Counter timing diagram with prescaler division change from 1 to 2. . . . .	437
Figure 171. Counter timing diagram with prescaler division change from 1 to 4. . . . .	437
Figure 172. Counter timing diagram, internal clock divided by 1. . . . .	438
Figure 173. Counter timing diagram, internal clock divided by 2. . . . .	439
Figure 174. Counter timing diagram, internal clock divided by 4. . . . .	439
Figure 175. Counter timing diagram, internal clock divided by N. . . . .	439
Figure 176. Counter timing diagram, update event when ARPE = 0 (TIMx_ARR not preloaded). . . . .	440
Figure 177. Counter timing diagram, update event when ARPE=1 (TIMx_ARR preloaded). . . . .	440
Figure 178. Control circuit in normal mode, internal clock divided by 1. . . . .	441
Figure 179. RTC simplified block diagram. . . . .	449
Figure 180. RTC second and alarm waveform example with PR=0003, ALARM=00004. . . . .	451
Figure 181. RTC Overflow waveform example with PR=0003. . . . .	451
Figure 182. Independent watchdog block diagram. . . . .	459
Figure 183. Watchdog block diagram. . . . .	465
Figure 184. Window watchdog timing diagram. . . . .	466
Figure 185. FSMC block diagram. . . . .	471
Figure 186. FSMC memory banks. . . . .	473
Figure 187. Mode1 read accesses. . . . .	480
Figure 188. Mode1 write accesses. . . . .	481
Figure 189. ModeA read accesses. . . . .	482
Figure 190. ModeA write accesses. . . . .	483
Figure 191. Mode2/B read accesses. . . . .	485
Figure 192. Mode2 write accesses. . . . .	485
Figure 193. ModeB write accesses. . . . .	486
Figure 194. ModeC read accesses. . . . .	488
Figure 195. ModeC write accesses. . . . .	488
Figure 196. ModeD read accesses. . . . .	490
Figure 197. Muxed read accesses. . . . .	492
Figure 198. Muxed write accesses. . . . .	492
Figure 199. Asynchronous wait during a read access. . . . .	494
Figure 200. Asynchronous wait during a write access. . . . .	495

Figure 201. Wait configurations . . . . .	497
Figure 202. Synchronous multiplexed read mode - NOR, PSRAM (CRAM) . . . . .	498
Figure 203. Synchronous multiplexed write mode - PSRAM (CRAM) . . . . .	500
Figure 204. NAND/PC Card controller timing for common memory access . . . . .	511
Figure 205. Access to non 'CE don't care' NAND-Flash . . . . .	512
Figure 206. SDIO "no response" and "no data" operations . . . . .	525
Figure 207. SDIO (multiple) block read operation . . . . .	525
Figure 208. SDIO (multiple) block write operation . . . . .	526
Figure 209. SDIO sequential read operation . . . . .	526
Figure 210. SDIO sequential write operation . . . . .	526
Figure 211. SDIO block diagram . . . . .	527
Figure 212. SDIO adapter . . . . .	528
Figure 213. Control unit . . . . .	529
Figure 214. SDIO adapter command path . . . . .	530
Figure 215. Command path state machine (CPSM) . . . . .	531
Figure 216. SDIO command transfer . . . . .	532
Figure 217. Data path . . . . .	534
Figure 218. Data path state machine (DPSM) . . . . .	535
Figure 219. USB peripheral block diagram . . . . .	581
Figure 220. Packet buffer areas with examples of buffer description table locations . . . . .	585
Figure 221. CAN network topology . . . . .	611
Figure 222. Dual CAN block diagram (connectivity devices) . . . . .	613
Figure 223. bxCAN operating modes . . . . .	615
Figure 224. bxCAN in silent mode . . . . .	616
Figure 225. bxCAN in loop back mode . . . . .	616
Figure 226. bxCAN in combined mode . . . . .	617
Figure 227. Transmit mailbox states . . . . .	618
Figure 228. Receive FIFO states . . . . .	619
Figure 229. Filter bank scale configuration - register organization . . . . .	622
Figure 230. Example of filter numbering . . . . .	623
Figure 231. Filtering mechanism - example . . . . .	624
Figure 232. CAN error state diagram . . . . .	625
Figure 233. Bit timing . . . . .	627
Figure 234. CAN frames . . . . .	628
Figure 235. Event flags and interrupt generation . . . . .	629
Figure 236. SPI block diagram . . . . .	657
Figure 237. Single master/ single slave application . . . . .	658
Figure 238. Hardware/software slave select management . . . . .	659
Figure 239. Data clock timing diagram . . . . .	660
Figure 240. TXE/RXNE/BSY behavior in Master / full-duplex mode (BIDIMODE=0 and RXONLY=0) in the case of continuous transfers . . . . .	665
Figure 241. TXE/RXNE/BSY behavior in Slave / full-duplex mode (BIDIMODE=0, RXONLY=0) in the case of continuous transfers . . . . .	666
Figure 242. TXE/BSY behavior in Master transmit-only mode (BIDIMODE=0 and RXONLY=0) in the case of continuous transfers . . . . .	667
Figure 243. TXE/BSY in Slave transmit-only mode (BIDIMODE=0 and RXONLY=0) in the case of continuous transfers . . . . .	667
Figure 244. RXNE behavior in receive-only mode (BIDIRMODE=0 and RXONLY=1) in the case of continuous transfers . . . . .	668
Figure 245. TXE/BSY behavior when transmitting (BIDIRMODE=0 and RXONLY=0) in the case of discontinuous transfers . . . . .	669
Figure 246. Transmission using DMA . . . . .	673

Figure 247. Reception using DMA . . . . .	674
Figure 248. I <sup>2</sup> S block diagram . . . . .	676
Figure 249. I <sup>2</sup> S Phillips protocol waveforms (16/32-bit full accuracy, CPOL = 0) . . . . .	678
Figure 250. I <sup>2</sup> S Phillips standard waveforms (24-bit frame with CPOL = 0) . . . . .	678
Figure 251. Transmitting 0x8EAA33 . . . . .	678
Figure 252. Receiving 0x8EAA33 . . . . .	679
Figure 253. I <sup>2</sup> S Phillips standard (16-bit extended to 32-bit packet frame with CPOL = 0) . . . . .	679
Figure 254. Example . . . . .	679
Figure 255. MSB Justified 16-bit or 32-bit full-accuracy length with CPOL = 0 . . . . .	680
Figure 256. MSB Justified 24-bit frame length with CPOL = 0 . . . . .	680
Figure 257. MSB Justified 16-bit extended to 32-bit packet frame with CPOL = 0 . . . . .	680
Figure 258. LSB justified 16-bit or 32-bit full-accuracy with CPOL = 0 . . . . .	681
Figure 259. LSB Justified 24-bit frame length with CPOL = 0 . . . . .	681
Figure 260. Operations required to transmit 0x3478AE . . . . .	681
Figure 261. Operations required to receive 0x3478AE . . . . .	682
Figure 262. LSB Justified 16-bit extended to 32-bit packet frame with CPOL = 0 . . . . .	682
Figure 263. Example . . . . .	682
Figure 264. PCM standard waveforms (16-bit) . . . . .	683
Figure 265. PCM standard waveforms (16-bit extended to 32-bit packet frame) . . . . .	683
Figure 266. Audio sampling frequency definition . . . . .	684
Figure 267. I <sup>2</sup> S clock generator architecture . . . . .	684
Figure 268. I2C bus protocol . . . . .	704
Figure 269. I2C block diagram . . . . .	705
Figure 270. Transfer sequence diagram for slave transmitter . . . . .	706
Figure 271. Transfer sequence diagram for slave receiver . . . . .	707
Figure 272. Transfer sequence diagram for master transmitter . . . . .	710
Figure 273. Method 1: transfer sequence diagram for master receiver . . . . .	711
Figure 274. Method 2: transfer sequence diagram for master receiver when N>2 . . . . .	712
Figure 275. Method 2: transfer sequence diagram for master receiver when N=2 . . . . .	713
Figure 276. Method 2: transfer sequence diagram for master receiver when N=1 . . . . .	714
Figure 277. I2C interrupt mapping diagram . . . . .	721
Figure 278. USART block diagram . . . . .	738
Figure 279. Word length programming . . . . .	739
Figure 280. Configurable stop bits . . . . .	741
Figure 281. TC/TXE behavior when transmitting . . . . .	742
Figure 282. Start bit detection . . . . .	743
Figure 283. Data sampling for noise detection . . . . .	745
Figure 284. Mute mode using Idle line detection . . . . .	750
Figure 285. Mute mode using Address mark detection . . . . .	750
Figure 286. Break detection in LIN mode (11-bit break length - LBDL bit is set) . . . . .	753
Figure 287. Break detection in LIN mode vs. Framing error detection . . . . .	754
Figure 288. USART example of synchronous transmission . . . . .	755
Figure 289. USART data clock timing diagram (M=0) . . . . .	755
Figure 290. USART data clock timing diagram (M=1) . . . . .	756
Figure 291. RX data setup/hold time . . . . .	756
Figure 292. ISO 7816-3 asynchronous protocol . . . . .	757
Figure 293. Parity error detection using the 1.5 stop bits . . . . .	758
Figure 294. IrDA SIR ENDEC- block diagram . . . . .	760
Figure 295. IrDA data modulation (3/16) -normal mode . . . . .	760
Figure 296. Transmission using DMA . . . . .	762
Figure 297. Reception using DMA . . . . .	763
Figure 298. Hardware flow control between 2 USART . . . . .	763

Figure 299. RTS flow control . . . . .	764
Figure 300. CTS flow control . . . . .	764
Figure 301. USART interrupt mapping diagram . . . . .	765
Figure 302. Block diagram . . . . .	780
Figure 303. OTG A-B device connection . . . . .	781
Figure 304. USB peripheral-only connection . . . . .	783
Figure 305. USB host-only connection . . . . .	788
Figure 306. SOF connectivity . . . . .	792
Figure 307. Device-mode FIFO address mapping and AHB FIFO access mapping . . . . .	795
Figure 308. Host-mode FIFO address mapping and AHB FIFO access mapping . . . . .	796
Figure 309. Interrupt hierarchy . . . . .	800
Figure 310. CSR memory map . . . . .	802
Figure 311. Transmit FIFO write task . . . . .	871
Figure 312. Receive FIFO read task . . . . .	872
Figure 313. Normal bulk/control OUT/SETUP and bulk/control IN transactions . . . . .	873
Figure 314. Bulk/control IN transactions . . . . .	876
Figure 315. Normal interrupt OUT/IN transactions . . . . .	878
Figure 316. Normal isochronous OUT/IN transactions . . . . .	883
Figure 317. Receive FIFO packet read . . . . .	889
Figure 318. Processing a SETUP packet . . . . .	891
Figure 319. Bulk OUT transaction . . . . .	897
Figure 320. TRDT max timing case . . . . .	906
Figure 321. A-Device SRP . . . . .	907
Figure 322. B-device SRP . . . . .	908
Figure 323. A-device HNP . . . . .	909
Figure 324. B-device HNP . . . . .	910
Figure 325. ETH block diagram . . . . .	916
Figure 326. SMI interface signals . . . . .	917
Figure 327. MDIO timing and frame structure - Write cycle . . . . .	918
Figure 328. MDIO timing and frame structure - Read cycle . . . . .	919
Figure 329. Media independent interface signals . . . . .	920
Figure 330. MII clock sources . . . . .	922
Figure 331. Reduced media-independent interface signals . . . . .	922
Figure 332. RMII clock sources . . . . .	923
Figure 333. Clock scheme . . . . .	923
Figure 334. Address field format . . . . .	925
Figure 335. MAC frame format . . . . .	927
Figure 336. Tagged MAC frame format . . . . .	927
Figure 337. Transmission bit order . . . . .	933
Figure 338. Transmission with no collision . . . . .	934
Figure 339. Transmission with collision . . . . .	934
Figure 340. Frame transmission in MMI and RMII modes . . . . .	935
Figure 341. Receive bit order . . . . .	939
Figure 342. Reception with no error . . . . .	939
Figure 343. Reception with errors . . . . .	939
Figure 344. Reception with false carrier indication . . . . .	940
Figure 345. MAC core interrupt masking scheme . . . . .	940
Figure 346. Wakeup frame filter register . . . . .	945
Figure 347. Networked time synchronization . . . . .	948
Figure 348. System time update using the Fine correction method . . . . .	950
Figure 349. PTP trigger output to TIM2 ITR1 connection . . . . .	952
Figure 350. PPS output . . . . .	953

---

Figure 351. Descriptor ring and chain structure . . . . .	954
Figure 352. TxDMA operation in Default mode . . . . .	958
Figure 353. TxDMA operation in OSF mode . . . . .	960
Figure 354. Transmit descriptor . . . . .	961
Figure 355. Transmit descriptor field format with IEEE1588 time stamp enabled . . . . .	966
Figure 356. Receive DMA operation . . . . .	971
Figure 357. Rx DMA descriptor structure . . . . .	973
Figure 358. Receive descriptor fields format with IEEE1588 time stamp enabled . . . . .	978
Figure 359. Interrupt scheme . . . . .	980
Figure 360. Ethernet MAC remote wakeup frame filter register (ETH_MACRWUFR) . . . . .	990
Figure 361. Block diagram of STM32F10xxx-level and Cortex-M3-level debug support . . . . .	1028
Figure 362. SWJ debug port . . . . .	1029
Figure 363. JTAG TAP connections . . . . .	1033
Figure 364. TPIU block diagram . . . . .	1050

# 1 Documentation conventions

## 1.1 List of abbreviations for registers

The following abbreviations are used in register descriptions:

read/write (rw)	Software can read and write to these bits.
read-only (r)	Software can only read these bits.
write-only (w)	Software can only write to this bit. Reading the bit returns the reset value.
read/clear (rc_w1)	Software can read as well as clear this bit by writing 1. Writing '0' has no effect on the bit value.
read/clear (rc_w0)	Software can read as well as clear this bit by writing 0. Writing '1' has no effect on the bit value.
read/clear by read (rc_r)	Software can read this bit. Reading this bit automatically clears it to '0'. Writing '0' has no effect on the bit value.
read/set (rs)	Software can read as well as set this bit. Writing '0' has no effect on the bit value.
read-only write trigger (rt_w)	Software can read this bit. Writing '0' or '1' triggers an event but has no effect on the bit value.
toggle (t)	Software can only toggle this bit by writing '1'. Writing '0' has no effect.
Reserved (Res.)	Reserved bit, must be kept at reset value.

## 1.2 Glossary

- **Low-density devices** are STM32F101xx, STM32F102xx and STM32F103xx microcontrollers where the Flash memory density ranges between 16 and 32 Kbytes.
- **Medium-density devices** are STM32F101xx, STM32F102xx and STM32F103xx microcontrollers where the Flash memory density ranges between 64 and 128 Kbytes.
- **High-density devices** are STM32F101xx and STM32F103xx microcontrollers where the Flash memory density ranges between 256 and 512 Kbytes.
- **XL-density devices** are STM32F101xx and STM32F103xx microcontrollers where the Flash memory density ranges between 768 Kbytes and 1 Mbyte.
- **Connectivity line devices** are STM32F105xx and STM32F107xx microcontrollers.
- **Word:** data of 32-bit length.
- **Half-word:** data of 16-bit length.
- **Byte:** data of 8-bit length.

## 1.3 Peripheral availability

For peripheral availability and number across all STM32F10xxx sales types, please refer to the low-, medium-, high- and XL-density STM32F101xx and STM32F103xx datasheets, to the low- and medium-density STM32F102xx datasheets and to the connectivity line devices, STM32F105xx/STM32F107xx.



## 2 Memory and bus architecture

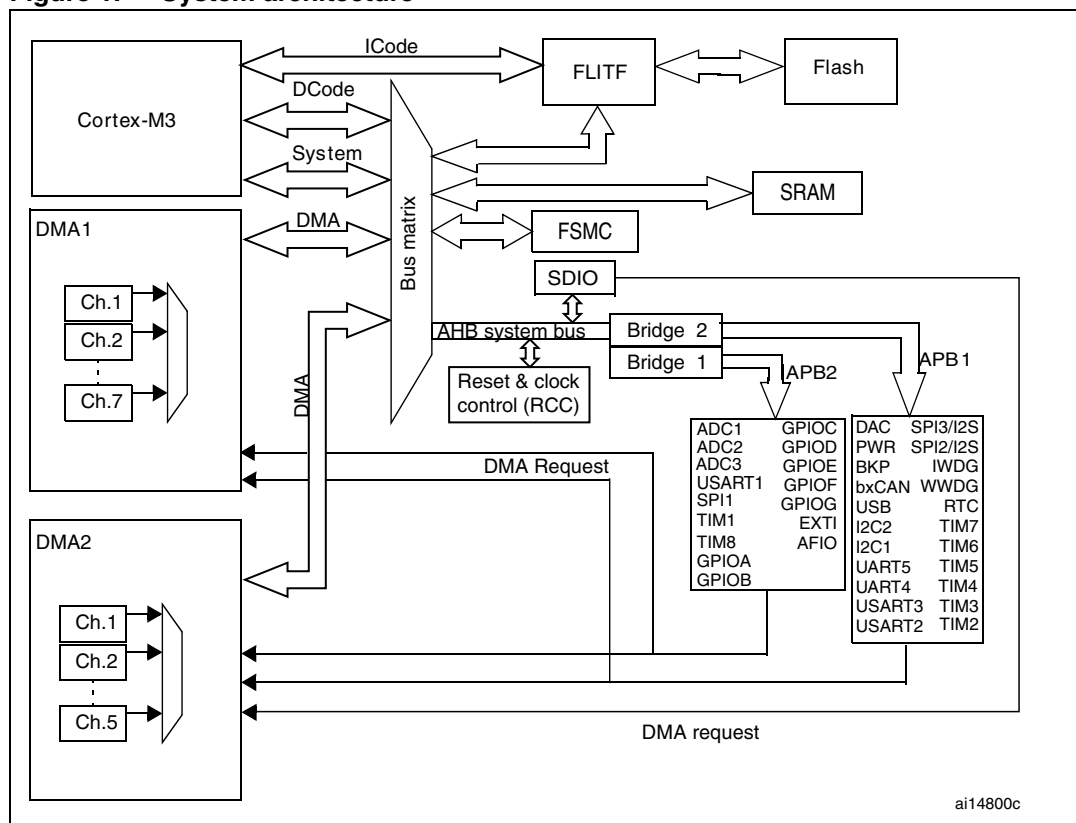
### 2.1 System architecture

In low-, medium-, high- and XL-density devices, the main system consists of:

- Four masters:
  - Cortex™-M3 core DCode bus (D-bus) and System bus (S-bus)
  - GP-DMA1 & 2 (general-purpose DMA)
- Four slaves:
  - Internal SRAM
  - Internal Flash memory
  - FSMC
  - AHB to APBx (APB1 or APB2), which connect all the APB peripherals

These are interconnected using a multilayer AHB bus architecture as shown in *Figure 1*:

**Figure 1. System architecture**

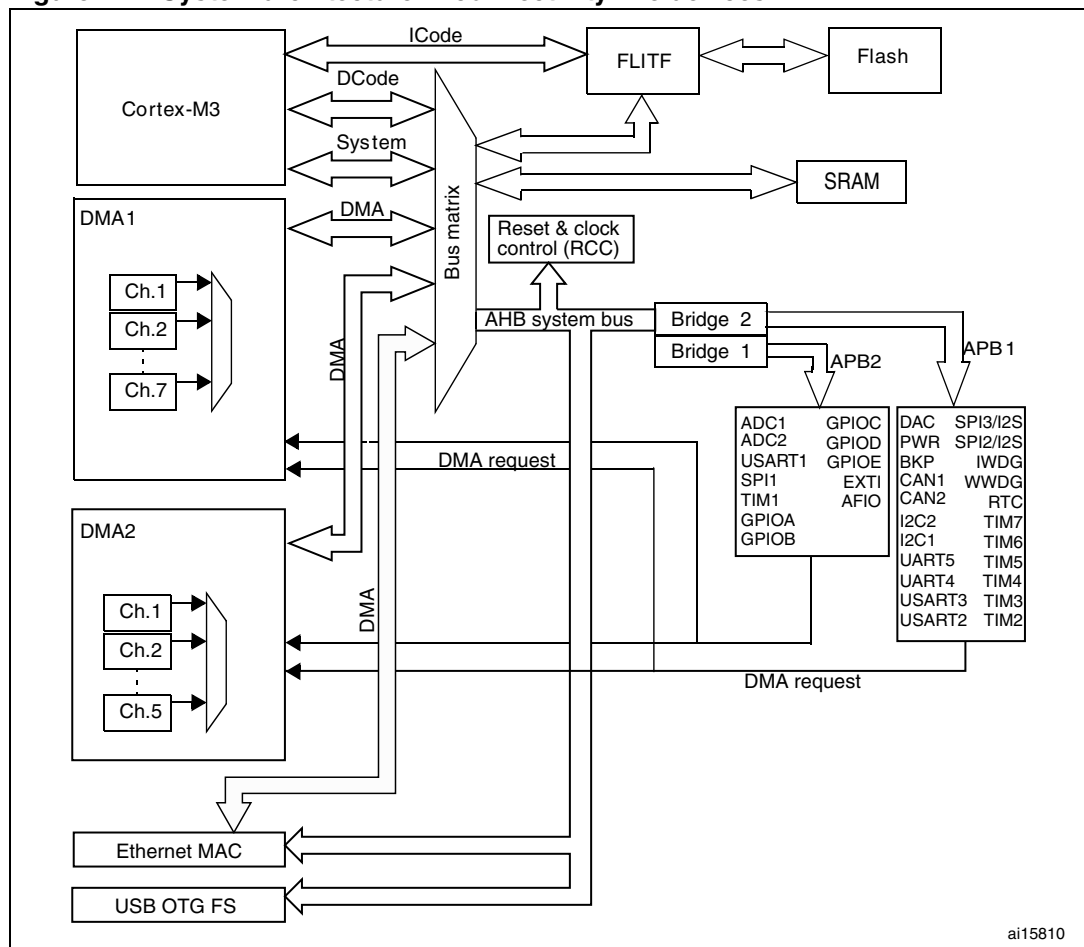


In connectivity line devices the main system consists of:

- Five masters:
  - Cortex™-M3 core DCode bus (D-bus) and System bus (S-bus)
  - GP-DMA1 & 2 (general-purpose DMA)
  - Ethernet DMA
- Three slaves:
  - Internal SRAM
  - Internal Flash memory
  - AHB to APB bridges (AHB to APBx), which connect all the APB peripherals

These are interconnected using a multilayer AHB bus architecture as shown in *Figure 2*:

**Figure 2. System architecture in connectivity line devices**



**ICode bus**

This bus connects the Instruction bus of the Cortex™-M3 core to the Flash memory instruction interface. Prefetching is performed on this bus.

### DCode bus

This bus connects the DCode bus (literal load and debug access) of the Cortex™-M3 core to the Flash memory Data interface.

### System bus

This bus connects the system bus of the Cortex™-M3 core (peripherals bus) to a BusMatrix which manages the arbitration between the core and the DMA.

### DMA bus

This bus connects the AHB master interface of the DMA to the BusMatrix which manages the access of CPU DCode and DMA to SRAM, Flash memory and peripherals.

### BusMatrix

The BusMatrix manages the access arbitration between the core system bus and the DMA master bus. The arbitration uses a Round Robin algorithm. In connectivity line devices, the BusMatrix is composed of five masters (CPU DCode, System bus, Ethernet DMA, DMA1 and DMA2 bus) and three slaves (FLITF, SRAM and AHB2APB bridges). In other devices, the BusMatrix is composed of four masters (CPU DCode, System bus, DMA1 bus and DMA2 bus) and four slaves (FLITF, SRAM, FSMC and AHB2APB bridges).

AHB peripherals are connected on system bus through a BusMatrix to allow DMA access.

### AHB/APB bridges (APB)

The two AHB/APB bridges provide full synchronous connections between the AHB and the 2 APB buses. APB1 is limited to 36 MHz, APB2 operates at full speed (up to 72 MHz depending on the device).

Refer to [Table 1 on page 44](#) for the address mapping of the peripherals connected to each bridge.

After each device reset, all peripheral clocks are disabled (except for the SRAM and FLITF). Before using a peripheral you have to enable its clock in the RCC\_AHBENR, RCC\_APB2ENR or RCC\_APB1ENR register.

*Note:* When a 16- or 8-bit access is performed on an APB register, the access is transformed into a 32-bit access: the bridge duplicates the 16- or 8-bit data to feed the 32-bit vector.

## 2.2 Memory organization

Program memory, data memory, registers and I/O ports are organized within the same linear 4-Gbyte address space.

The bytes are coded in memory in Little Endian format. The lowest numbered byte in a word is considered the word's least significant byte and the highest numbered byte the most significant.

For the detailed mapping of peripheral registers, please refer to the related chapters.

The addressable memory space is divided into 8 main blocks, each of 512 MB.

All the memory areas that are not allocated to on-chip memories and peripherals are considered "Reserved". Refer to the Memory map figure in the corresponding product datasheet.

## 2.3 Memory map

See the datasheet corresponding to your device for a comprehensive diagram of the memory map. [Table 1](#) gives the boundary addresses of the peripherals available in all STM32F10xxx devices.

**Table 1. Register boundary addresses**

Boundary address	Peripheral	Bus	Register map
0x5000 0000 - 0x5003 FFFF	USB OTG FS	AHB	<a href="#">Section 27.15.6 on page 861</a>
0x4003 0000 - 0x4FFF FFFF	Reserved		
0x4002 8000 - 0x4002 9FFF	Ethernet		<a href="#">Section 28.8.5 on page 1021</a>
0x4002 3400 - 0x4002 7FFF	Reserved		
0x4002 3000 - 0x4002 33FF	CRC		<a href="#">Section 3.4.4 on page 58</a>
0x4002 2000 - 0x4002 23FF	Flash memory interface		
0x4002 1400 - 0x4002 1FFF	Reserved		
0x4002 1000 - 0x4002 13FF	Reset and clock control RCC		<a href="#">Section 6.3.11 on page 111</a>
0x4002 0800 - 0x4002 0FFF	Reserved		
0x4002 0400 - 0x4002 07FF	DMA2		<a href="#">Section 10.4.7 on page 212</a>
0x4002 0000 - 0x4002 03FF	DMA1		<a href="#">Section 10.4.7 on page 212</a>
0x4001 8400 - 0x4001 7FFF	Reserved		
0x4001 8000 - 0x4001 83FF	SDIO		<a href="#">Section 21.9.16 on page 578</a>

Table 1. Register boundary addresses (continued)

Boundary address	Peripheral	Bus	Register map
0x4001 5800 - 0x4001 7FFF	Reserved	APB2	
0x4001 5400 - 0x4001 57FF	TIM11 timer		<a href="#">Section 15.5.14 on page 424</a>
0x4001 5000 - 0x4001 53FF	TIM10 timer		<a href="#">Section 15.5.14 on page 424</a>
0x4001 4C00 - 0x4001 4FFF	TIM9 timer		<a href="#">Section 15.5.14 on page 424</a>
0x4001 4000 - 0x4001 4BFF	Reserved		
0x4001 3C00 - 0x4001 3FFF	ADC3		<a href="#">Section 11.12.15 on page 247</a>
0x4001 3800 - 0x4001 3BFF	USART1		<a href="#">Section 26.6.8 on page 776</a>
0x4001 3400 - 0x4001 37FF	TIM8 timer		<a href="#">Section 13.4.21 on page 333</a>
0x4001 3000 - 0x4001 33FF	SPI1		<a href="#">Section 24.5 on page 692</a>
0x4001 2C00 - 0x4001 2FFF	TIM1 timer		<a href="#">Section 13.4.21 on page 333</a>
0x4001 2800 - 0x4001 2BFF	ADC2		<a href="#">Section 11.12.15 on page 247</a>
0x4001 2400 - 0x4001 27FF	ADC1		<a href="#">Section 11.12.15 on page 247</a>
0x4001 2000 - 0x4001 23FF	GPIO Port G		<a href="#">Section 8.5 on page 179</a>
0x4001 1C00 - 0x4001 1FFF	GPIO Port F		<a href="#">Section 8.5 on page 179</a>
0x4001 1800 - 0x4001 1BFF	GPIO Port E		<a href="#">Section 8.5 on page 179</a>
0x4001 1400 - 0x4001 17FF	GPIO Port D		<a href="#">Section 8.5 on page 179</a>
0x4001 1000 - 0x4001 13FF	GPIO Port C		<a href="#">Section 8.5 on page 179</a>
0x4001 0C00 - 0x4001 0FFF	GPIO Port B		<a href="#">Section 8.5 on page 179</a>
0x4001 0800 - 0x4001 0BFF	GPIO Port A		<a href="#">Section 8.5 on page 179</a>
0x4001 0400 - 0x4001 07FF	EXTI		<a href="#">Section 9.3.7 on page 196</a>
0x4001 0000 - 0x4001 03FF	AFIO	<a href="#">Section 8.5 on page 179</a>	

**Table 1. Register boundary addresses (continued)**

Boundary address	Peripheral	Bus	Register map
0x4000 7800 - 0x4000 FFFF	Reserved	APB1	
0x4000 7400 - 0x4000 77FF	DAC		<a href="#">Section 12.5.14 on page 268</a>
0x4000 7000 - 0x4000 73FF	Power control PWR		<a href="#">Section 4.4.3 on page 72</a>
0x4000 6C00 - 0x4000 6FFF	Backup registers (BKP)		<a href="#">Section 5.4.5 on page 77</a>
0x4000 6800 - 0x4000 6BFF	Reserved		
0x4000 6400 - 0x4000 67FF	bxCAN1		<a href="#">Section 23.9.5 on page 651</a>
0x4000 6800 - 0x4000 6BFF	bxCAN2		<a href="#">Section 23.9.5 on page 651</a>
0x4000 6000 <sup>(1)</sup> - 0x4000 63FF	Shared USB/CAN SRAM 512 bytes		
0x4000 5C00 - 0x4000 5FFF	USB device FS registers		<a href="#">Section 22.5.4 on page 608</a>
0x4000 5800 - 0x4000 5BFF	I2C2		<a href="#">Section 25.6.10 on page 733</a>
0x4000 5400 - 0x4000 57FF	I2C1		<a href="#">Section 25.6.10 on page 733</a>
0x4000 5000 - 0x4000 53FF	UART5		<a href="#">Section 26.6.8 on page 776</a>
0x4000 4C00 - 0x4000 4FFF	UART4		<a href="#">Section 26.6.8 on page 776</a>
0x4000 4800 - 0x4000 4BFF	USART3		<a href="#">Section 26.6.8 on page 776</a>
0x4000 4400 - 0x4000 47FF	USART2		<a href="#">Section 26.6.8 on page 776</a>
0x4000 4000 - 0x4000 3FFF	Reserved		
0x4000 3C00 - 0x4000 3FFF	SPI3/I2S		<a href="#">Section 24.5 on page 692</a>
0x4000 3800 - 0x4000 3BFF	SPI2/I2S		<a href="#">Section 24.5 on page 692</a>
0x4000 3400 - 0x4000 37FF	Reserved		
0x4000 3000 - 0x4000 33FF	Independent watchdog (IWDG)		<a href="#">Section 18.4.5 on page 463</a>
0x4000 2C00 - 0x4000 2FFF	Window watchdog (WWDG)		<a href="#">Section 19.6.4 on page 468</a>
0x4000 2800 - 0x4000 2BFF	RTC		<a href="#">Section 17.4.7 on page 457</a>
0x4000 2400 - 0x4000 27FF	Reserved		
0x4000 2000 - 0x4000 23FF	TIM14 timer		<a href="#">Section 15.6.12 on page 433</a>
0x4000 1C00 - 0x4000 1FFF	TIM13 timer		<a href="#">Section 15.6.12 on page 433</a>
0x4000 1800 - 0x4000 1BFF	TIM12 timer		<a href="#">Section 15.6.12 on page 433</a>
0x4000 1400 - 0x4000 17FF	TIM7 timer		<a href="#">Section 16.4.9 on page 446</a>
0x4000 1000 - 0x4000 13FF	TIM6 timer		<a href="#">Section 16.4.9 on page 446</a>
0x4000 0C00 - 0x4000 0FFF	TIM5 timer		<a href="#">Section 14.4.19 on page 389</a>
0x4000 0800 - 0x4000 0BFF	TIM4 timer		<a href="#">Section 14.4.19 on page 389</a>
0x4000 0400 - 0x4000 07FF	TIM3 timer		<a href="#">Section 14.4.19 on page 389</a>
0x4000 0000 - 0x4000 03FF	TIM2 timer		<a href="#">Section 14.4.19 on page 389</a>

1. This shared SRAM can be fully accessed only in low-, medium-, high- and XL-density devices, not in connectivity line devices.

### 2.3.1 Embedded SRAM

The STM32F10xxx features up to 96 Kbytes of static SRAM. It can be accessed as bytes, half-words (16 bits) or full words (32 bits). The SRAM start address is 0x2000 0000.

### 2.3.2 Bit banding

The Cortex™-M3 memory map includes two bit-band regions. These regions map each word in an alias region of memory to a bit in a bit-band region of memory. Writing to a word in the alias region has the same effect as a read-modify-write operation on the targeted bit in the bit-band region.

In the STM32F10xxx both peripheral registers and SRAM are mapped in a bit-band region. This allows single bit-band write and read operations to be performed. The operations are only available for Cortex-M3 accesses, not from other bus masters (e.g. DMA).

A mapping formula shows how to reference each word in the alias region to a corresponding bit in the bit-band region. The mapping formula is:

$$bit\_word\_addr = bit\_band\_base + (byte\_offset \times 32) + (bit\_number \times 4)$$

where:

*bit\_word\_addr* is the address of the word in the alias memory region that maps to the targeted bit.

*bit\_band\_base* is the starting address of the alias region

*byte\_offset* is the number of the byte in the bit-band region that contains the targeted bit

*bit\_number* is the bit position (0-7) of the targeted bit.

#### Example:

The following example shows how to map bit 2 of the byte located at SRAM address 0x20000300 in the alias region:

$$0x22006008 = 0x22000000 + (0x300 \times 32) + (2 \times 4).$$

Writing to address 0x22006008 has the same effect as a read-modify-write operation on bit 2 of the byte at SRAM address 0x20000300.

Reading address 0x22006008 returns the value (0x01 or 0x00) of bit 2 of the byte at SRAM address 0x20000300 (0x01: bit set; 0x00: bit reset).

For more information on Bit-Banding, please refer to the *Cortex™-M3 Technical Reference Manual*.

### 2.3.3 Embedded Flash memory

The high-performance Flash memory module has the following key features:

- For XL-density devices: density of up to 1 Mbyte with dual bank architecture for read-while-write (RWW) capability:
  - bank 1: fixed size of 512 Kbytes
  - bank 2: up to 512 Kbytes
- For other devices: density of up to 512 Kbytes
- Memory organization: the Flash memory is organized as a main block and an information block:
  - Main memory block of size:
    - up to 128 Kbytes × 64 bits divided into 512 pages of 2 Kbytes each (see [Table 6](#)) for XL-density devices
    - up to 4 Kb × 64 bits divided into 32 pages of 1 Kbyte each for low-density devices (see [Table 2](#))
    - up to 16 Kb × 64 bits divided into 128 pages of 1 Kbyte each for medium-density devices (see [Table 3](#))
    - up to 64 Kb × 64 bits divided into 256 pages of 2 Kbytes each (see [Table 4](#)) for high-density devices
    - up to 32 Kbit × 64 bits divided into 128 pages of 2 Kbytes each (see [Table 5](#)) for connectivity line devices
  - Information block of size:
    - 770 × 64 bits for XL-density devices (see [Table 6](#))
    - 2360 × 64 bits for connectivity line devices (see [Table 5](#))
    - 258 × 64 bits for other devices (see [Table 2](#), [Table 3](#) and [Table 4](#))

The Flash memory interface (FLITF) features:

- Read interface with prefetch buffer (2x64-bit words)
- Option byte Loader
- Flash Program / Erase operation
- Read / Write protection

**Table 2. Flash module organization (low-density devices)**

Block	Name	Base addresses	Size (bytes)
Main memory	Page 0	0x0800 0000 - 0x0800 03FF	1 Kbyte
	Page 1	0x0800 0400 - 0x0800 07FF	1 Kbyte
	Page 2	0x0800 0800 - 0x0800 0BFF	1 Kbyte
	Page 3	0x0800 0C00 - 0x0800 0FFF	1 Kbyte
	Page 4	0x0800 1000 - 0x0800 13FF	1 Kbyte
	.	.	.
	.	.	.
	Page 31	0x0800 7C00 - 0x0800 7FFF	1 Kbyte



**Table 2. Flash module organization (low-density devices) (continued)**

Block	Name	Base addresses	Size (bytes)
Information block	System memory	0x1FFF F000 - 0x1FFF F7FF	2 Kbytes
	Option Bytes	0x1FFF F800 - 0x1FFF F80F	16
Flash memory interface registers	FLASH_ACR	0x4002 2000 - 0x4002 2003	4
	FLASH_KEYR	0x4002 2004 - 0x4002 2007	4
	FLASH_OPTKEYR	0x4002 2008 - 0x4002 200B	4
	FLASH_SR	0x4002 200C - 0x4002 200F	4
	FLASH_CR	0x4002 2010 - 0x4002 2013	4
	FLASH_AR	0x4002 2014 - 0x4002 2017	4
	Reserved	0x4002 2018 - 0x4002 201B	4
	FLASH_OBR	0x4002 201C - 0x4002 201F	4
	FLASH_WRPR	0x4002 2020 - 0x4002 2023	4

**Table 3. Flash module organization (medium-density devices)**

Block	Name	Base addresses	Size (bytes)
Main memory	Page 0	0x0800 0000 - 0x0800 03FF	1 Kbyte
	Page 1	0x0800 0400 - 0x0800 07FF	1 Kbyte
	Page 2	0x0800 0800 - 0x0800 0BFF	1 Kbyte
	Page 3	0x0800 0C00 - 0x0800 0FFF	1 Kbyte
	Page 4	0x0800 1000 - 0x0800 13FF	1 Kbyte
	.	.	.
	.	.	.
	Page 127	0x0801 FC00 - 0x0801 FFFF	1 Kbyte
Information block	System memory	0x1FFF F000 - 0x1FFF F7FF	2 Kbytes
	Option Bytes	0x1FFF F800 - 0x1FFF F80F	16
Flash memory interface registers	FLASH_ACR	0x4002 2000 - 0x4002 2003	4
	FLASH_KEYR	0x4002 2004 - 0x4002 2007	4
	FLASH_OPTKEYR	0x4002 2008 - 0x4002 200B	4
	FLASH_SR	0x4002 200C - 0x4002 200F	4
	FLASH_CR	0x4002 2010 - 0x4002 2013	4
	FLASH_AR	0x4002 2014 - 0x4002 2017	4
	Reserved	0x4002 2018 - 0x4002 201B	4
	FLASH_OBR	0x4002 201C - 0x4002 201F	4
	FLASH_WRPR	0x4002 2020 - 0x4002 2023	4

**Table 4. Flash module organization (high-density devices)**

Block	Name	Base addresses	Size (bytes)
Main memory	Page 0	0x0800 0000 - 0x0800 07FF	2 Kbytes
	Page 1	0x0800 0800 - 0x0800 0FFF	2 Kbytes
	Page 2	0x0800 1000 - 0x0800 17FF	2 Kbytes
	Page 3	0x0800 1800 - 0x0800 1FFF	2 Kbytes
	.	.	.
	Page 255	0x0807 F800 - 0x0807 FFFF	2 Kbytes
Information block	System memory	0x1FFF F000 - 0x1FFF F7FF	2 Kbytes
	Option Bytes	0x1FFF F800 - 0x1FFF F80F	16
Flash memory interface registers	FLASH_ACR	0x4002 2000 - 0x4002 2003	4
	FLASH_KEYR	0x4002 2004 - 0x4002 2007	4
	FLASH_OPTKEYR	0x4002 2008 - 0x4002 200B	4
	FLASH_SR	0x4002 200C - 0x4002 200F	4
	FLASH_CR	0x4002 2010 - 0x4002 2013	4
	FLASH_AR	0x4002 2014 - 0x4002 2017	4
	Reserved	0x4002 2018 - 0x4002 201B	4
	FLASH_OBR	0x4002 201C - 0x4002 201F	4
	FLASH_WRPR	0x4002 2020 - 0x4002 2023	4

**Table 5. Flash module organization (connectivity line devices)**

Block	Name	Base addresses	Size (bytes)
Main memory	Page 0	0x0800 0000 - 0x0800 07FF	2 Kbytes
	Page 1	0x0800 0800 - 0x0800 0FFF	2 Kbytes
	Page 2	0x0800 1000 - 0x0800 17FF	2 Kbytes
	Page 3	0x0800 1800 - 0x0800 1FFF	2 Kbytes
	.	.	.
	Page 127	0x0803 F800 - 0x0803 FFFF	2 Kbytes
Information block	System memory	0x1FFF B000 - 0x1FFF F7FF	18 Kbytes
	Option Bytes	0x1FFF F800 - 0x1FFF F80F	16
Flash memory interface registers	FLASH_ACR	0x4002 2000 - 0x4002 2003	4
	FLASH_KEYR	0x4002 2004 - 0x4002 2007	4
	FLASH_OPTKEYR	0x4002 2008 - 0x4002 200B	4
	FLASH_SR	0x4002 200C - 0x4002 200F	4
	FLASH_CR	0x4002 2010 - 0x4002 2013	4
	FLASH_AR	0x4002 2014 - 0x4002 2017	4
	Reserved	0x4002 2018 - 0x4002 201B	4
	FLASH_OBR	0x4002 201C - 0x4002 201F	4
	FLASH_WRP	0x4002 2020 - 0x4002 2023	4

**Table 6. XL-density Flash module organization**

Block	Name	Base addresses	Size (bytes)	
Main memory	Bank 1	Page 0	0x0800 0000 - 0x0800 07FF	2 Kbytes
		Page 1	0x0800 0800 - 0x0800 0FFF	2 Kbytes
		...	...	...
		Page 255	0x0807 F800 - 0x0807 FFFF	2 Kbytes
	Bank 2	Page 256	0x0808 0000 - 0x0808 07FF	2 Kbytes
		Page 257	0x0808 0800 - 0x0808 0FFF	2 Kbytes
		.	.	.
		Page 511	0x080F F800 - 0x080F FFFF	2 Kbytes
Information block	System memory	0x1FFF E000 - 0x1FFF F7FF	6 Kbytes	
	Option bytes	0x1FFF F800 - 0x1FFF F80F	16	

**Table 6. XL-density Flash module organization (continued)**

Block	Name	Base addresses	Size (bytes)
Flash memory interface registers	FLASH_ACR	0x4002 2000 - 0x4002 2003	4
	FLASH_KEYR	0x4002 2004 - 0x4002 2007	4
	FLASH_OPTKEYR	0x4002 2008 - 0x4002 200B	4
	FLASH_SR	0x4002 200C - 0x4002 200F	4
	FLASH_CR	0x4002 2010 - 0x4002 2013	4
	FLASH_AR	0x4002 2014 - 0x4002 2017	4
	Reserved	0x4002 2018 - 0x4002 201B	4
	FLASH_OBR	0x4002 201C - 0x4002 201F	4
	FLASH_WRPR	0x4002 2020 - 0x4002 2023	4
	Reserved	0x4002 2024 - 0x4002 2043	32
	FLASH_KEYR2	0x4002 2044 - 0x4002 2047	4
	Reserved	0x4002 2048 - 0x4002 204B	4
	FLASH_SR2	0x4002 204C - 0x4002 204F	4
	FLASH_CR2	0x4002 2050 - 0x4002 2053	4
	FLASH_AR2	0x4002 2054 - 0x4002 2057	4

Note: For further information on the Flash memory interface registers, please refer to the:

- “STM32F10xxx XL-density Flash programming manual” (PM0068) for XL-density devices
- “STM32F10xxx Flash programming manual” (PM0042) for other devices

### Reading the Flash memory

Flash memory instructions and data access are performed through the AHB bus. The prefetch block is used for instruction fetches through the ICode bus. Arbitration is performed in the Flash memory interface, and priority is given to data access on the DCode bus.

Read accesses can be performed with the following configuration options:

- Latency: number of wait states for a read operation programmed on-the-fly
- Prefetch buffer (2 x 64-bit blocks): it is enabled after reset; a whole block can be replaced with a single read from the Flash memory as the size of the block matches the bandwidth of the Flash memory. Thanks to the prefetch buffer, faster CPU execution is possible as the CPU fetches one word at a time with the next word readily available in the prefetch buffer
- Half cycle: for power optimization

- Note: 1 *These options should be used in accordance with the Flash memory access time. The wait states represent the ratio of the SYSCLK (system clock) period to the Flash memory access time:*
- zero wait state, if  $0 < \text{SYSCLK} \leq 24 \text{ MHz}$*
  - one wait state, if  $24 \text{ MHz} < \text{SYSCLK} \leq 48 \text{ MHz}$*
  - two wait states, if  $48 \text{ MHz} < \text{SYSCLK} \leq 72 \text{ MHz}$*
- 2 *Half cycle configuration is not available in combination with a prescaler on the AHB. The system clock (SYSCLK) should be equal to the HCLK clock. This feature can therefore be used only with a low-frequency clock of 8 MHz or less. It can be generated from the HSI or the HSE but not from the PLL.*
- 3 *The prefetch buffer must be kept on when using a prescaler different from 1 on the AHB clock.*
- 4 *The prefetch buffer must be switched on/off only when SYSCLK is lower than 24 MHz and no prescaler is applied on the AHB clock (SYSCLK must be equal to HCLK). The prefetch buffer is usually switched on/off during the initialization routine, while the microcontroller is running on the internal 8 MHz RC (HSI) oscillator.*
- 5 *Using DMA: DMA accesses Flash memory on the DCode bus and has priority over ICode instructions. The DMA provides one free cycle after each transfer. Some instructions can be performed together with DMA transfer.*

### **Programming and erasing the Flash memory**

The Flash memory can be programmed 16 bits (half words) at a time.

The Flash memory erase operation can be performed at page level or on the whole Flash area (mass-erase). The mass-erase does not affect the information blocks.

To ensure that there is no over-programming, the Flash Programming and Erase Controller blocks are clocked by a fixed clock.

The End of write operation (programming or erasing) can trigger an interrupt. This interrupt can be used to exit from WFI mode, only if the FLITF clock is enabled. Otherwise, the interrupt is served only after an exit from WFI.

The FLASH\_ACR register is used to enable/disable prefetch and half cycle access, and to control the Flash memory access time according to the CPU frequency. The tables below provide the bit map and bit descriptions for this register.

For complete information on Flash memory operations and register configurations, please refer to the STM32F10xxx Flash programming manual (PM0042) or to the XL STM32F10xxx Flash programming manual (PM0068).

**Flash access control register (FLASH\_ACR)**

Address offset: 0x00

Reset value: 0x0000 0030

31	30	29	28	27	26	25	24	23	22	21	20	19	18	17	16
Reserved															
15	14	13	12	11	10	9	8	7	6	5	4	3	2	1	0
Reserved										PRFTBS	PRFTBE	HLFCYA	LATENCY		
										r	rw	rw	rw	rw	rw

Bits 31:6 Reserved, must be kept cleared.

Bit 5 **PRFTBS**: Prefetch buffer status

This bit provides the status of the prefetch buffer.

- 0: Prefetch buffer is disabled
- 1: Prefetch buffer is enabled

Bit 4 **PRFTBE**: Prefetch buffer enable

- 0: Prefetch is disabled
- 1: Prefetch is enabled

Bit 3 **HLFCYA**: Flash half cycle access enable

- 0: Half cycle is disabled
- 1: Half cycle is enabled

Bits 2:0 **LATENCY**: Latency

These bits represent the ratio of the SYSCLK (system clock) period to the Flash access time.

- 000 Zero wait state, if  $0 < \text{SYSCLK} \leq 24 \text{ MHz}$
- 001 One wait state, if  $24 \text{ MHz} < \text{SYSCLK} \leq 48 \text{ MHz}$
- 010 Two wait states, if  $48 \text{ MHz} < \text{SYSCLK} \leq 72 \text{ MHz}$

## 2.4 Boot configuration

In the STM32F10xxx, 3 different boot modes can be selected through BOOT[1:0] pins as shown in [Table 7](#).

**Table 7. Boot modes**

Boot mode selection pins		Boot mode	Aliasing
BOOT1	BOOT0		
x	0	Main Flash memory	Main Flash memory is selected as boot space
0	1	System memory	System memory is selected as boot space
1	1	Embedded SRAM	Embedded SRAM is selected as boot space

The values on the BOOT pins are latched on the 4th rising edge of SYSCLK after a reset. It is up to the user to set the BOOT1 and BOOT0 pins after Reset to select the required boot mode.

The BOOT pins are also re-sampled when exiting from Standby mode. Consequently they must be kept in the required Boot mode configuration in Standby mode. After this startup

delay has elapsed, the CPU fetches the top-of-stack value from address 0x0000 0000, then starts code execution from the boot memory starting from 0x0000 0004.

Due to its fixed memory map, the code area starts from address 0x0000 0000 (accessed through the ICode/DCode buses) while the data area (SRAM) starts from address 0x2000 0000 (accessed through the system bus). The Cortex-M3 CPU always fetches the reset vector on the ICode bus, which implies to have the boot space available only in the code area (typically, Flash memory). STM32F10xxx microcontrollers implement a special mechanism to be able to boot also from SRAM and not only from main Flash memory and System memory.

Depending on the selected boot mode, main Flash memory, system memory or SRAM is accessible as follows:

- Boot from main Flash memory: the main Flash memory is aliased in the boot memory space (0x0000 0000), but still accessible from its original memory space (0x800 0000). In other words, the Flash memory contents can be accessed starting from address 0x0000 0000 or 0x800 0000.
- Boot from system memory: the system memory is aliased in the boot memory space (0x0000 0000), but still accessible from its original memory space (0x1FFF B000 in connectivity line devices, 0x1FFF F000 in other devices).
- Boot from the embedded SRAM: SRAM is accessible only at address 0x2000 0000.

*Note:* When booting from SRAM, in the application initialization code, you have to relocate the vector table in SRAM using the NVIC exception table and offset register.

For XL-density devices, when booting from the main Flash memory, you have an option to boot from any of two memory banks. By default, boot from Flash memory bank 1 is selected. You can choose to boot from Flash memory bank 2 by clearing the BFB2 bit in the user option bytes. When this bit is cleared and the boot pins are in the boot from main Flash memory configuration, the device boots from system memory, and the boot loader jumps to execute the user application programmed in Flash memory bank 2. For further details, please refer to AN2606.

*Note:* When booting from Bank2, in the applications initialization code, you have to relocate the vector table to the Bank2 base address. (0x0808 0000) using the NVIC exception table and offset register.

### Embedded boot loader

The embedded boot loader is located in the System memory, programmed by ST during production. It is used to reprogram the Flash memory with one of the available serial interfaces:

- In low-, medium- and high-density devices the boot loader is activated through the USART1 interface.
- In XL-density devices the boot loader is activated through the following interfaces: USART1 or USART2 (remapped).
- In connectivity line devices the boot loader can be activated through one of the following interfaces: USART1, USART2 (remapped), CAN2 (remapped) or USB OTG FS in Device mode (DFU: device firmware upgrade).  
The USART peripheral operates with the internal 8 MHz oscillator (HSI). The CAN and USB OTG FS, however, can only function if an external 8 MHz, 14.7456 MHz or 25 MHz clock (HSE) is present.

*Note:* For further details, please refer to AN2606.

### 3 CRC calculation unit

**Low-density devices** are STM32F101xx, STM32F102xx and STM32F103xx microcontrollers where the Flash memory density ranges between 16 and 32 Kbytes.

**Medium-density devices** are STM32F101xx, STM32F102xx and STM32F103xx microcontrollers where the Flash memory density ranges between 64 and 128 Kbytes.

**High-density devices** are STM32F101xx and STM32F103xx microcontrollers where the Flash memory density ranges between 256 and 512 Kbytes.

**XL-density devices** are STM32F101xx and STM32F103xx microcontrollers where the Flash memory density ranges between 768 Kbytes and 1 Mbyte.

**Connectivity line devices** are STM32F105xx and STM32F107xx microcontrollers.

This section applies to the whole STM32F10xxx family, unless otherwise specified.

#### 3.1 CRC introduction

The CRC (cyclic redundancy check) calculation unit is used to get a CRC code from a 32-bit data word and a fixed generator polynomial.

Among other applications, CRC-based techniques are used to verify data transmission or storage integrity. In the scope of the EN/IEC 60335-1 standard, they offer a means of verifying the Flash memory integrity. The CRC calculation unit helps compute a signature of the software during runtime, to be compared with a reference signature generated at link-time and stored at a given memory location.

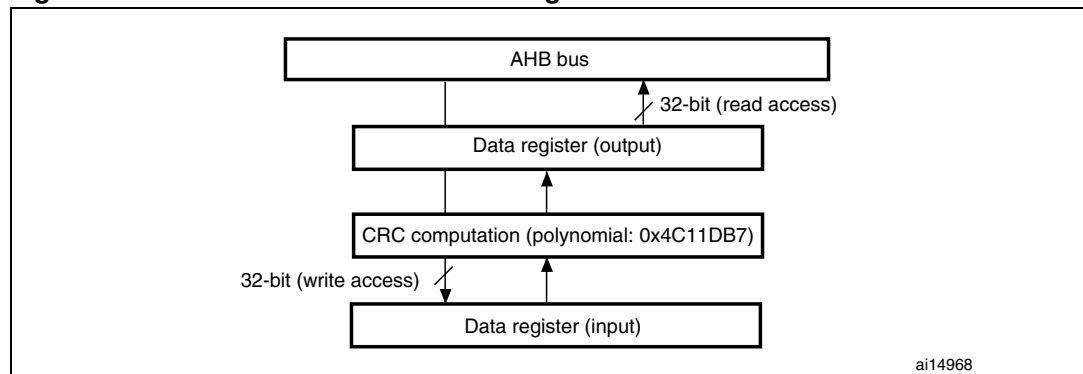
#### 3.2 CRC main features

- Uses CRC-32 (Ethernet) polynomial:  $0x4C11DB7$   

$$- X^{32} + X^{26} + X^{23} + X^{22} + X^{16} + X^{12} + X^{11} + X^{10} + X^8 + X^7 + X^5 + X^4 + X^2 + X + 1$$
- Single input/output 32-bit data register
- CRC computation done in 4 AHB clock cycles (HCLK)
- General-purpose 8-bit register (can be used for temporary storage)

The block diagram is shown in [Figure 3](#).

**Figure 3. CRC calculation unit block diagram**





### 3.3 CRC functional description

The CRC calculation unit mainly consists of a single 32-bit data register, which:

- is used as an input register to enter new data in the CRC calculator (when writing into the register)
- holds the result of the previous CRC calculation (when reading the register)

Each write operation into the data register creates a combination of the previous CRC value and the new one (CRC computation is done on the whole 32-bit data word, and not byte per byte).

The write operation is stalled until the end of the CRC computation, thus allowing back-to-back write accesses or consecutive write and read accesses.

The CRC calculator can be reset to FFFF FFFFh with the RESET control bit in the CRC\_CR register. This operation does not affect the contents of the CRC\_IDR register.

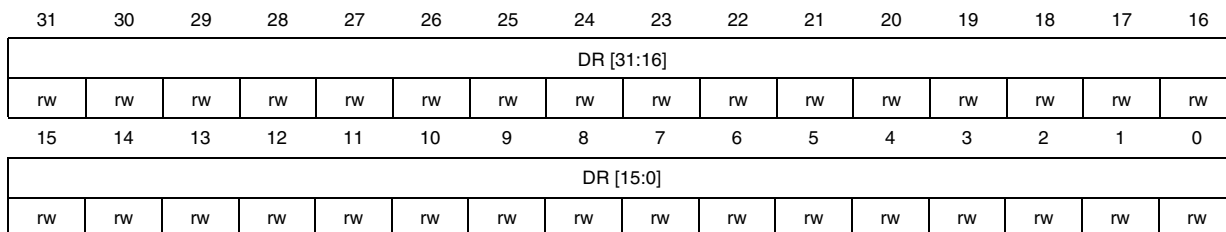
### 3.4 CRC registers

The CRC calculation unit contains two data registers and a control register.

#### 3.4.1 Data register (CRC\_DR)

Address offset: 0x00

Reset value: 0xFFFF FFFF



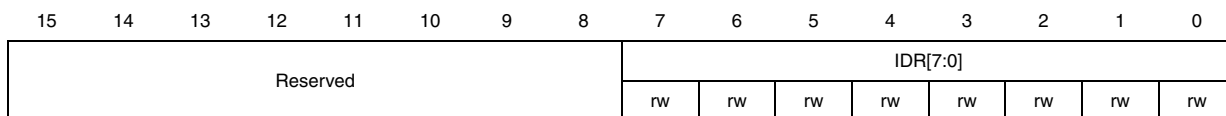
**Bits 31:0 Data register bits**

Used as an input register when writing new data into the CRC calculator.  
 Holds the previous CRC calculation result when it is read.

#### 3.4.2 Independent data register (CRC\_IDR)

Address offset: 0x04

Reset value: 0x0000 0000



Bits 31:8 Reserved

Bits 7:0 **General-purpose 8-bit data register bits**

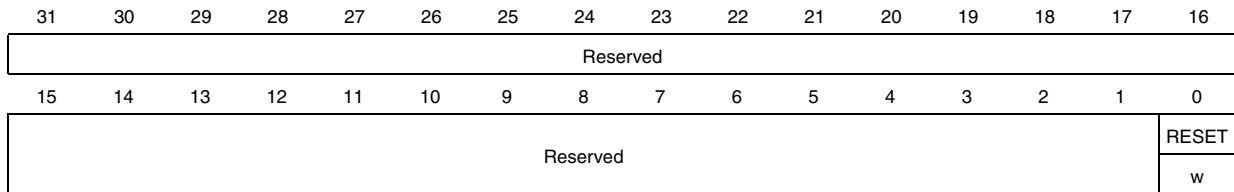
Can be used as a temporary storage location for one byte.

This register is not affected by CRC resets generated by the RESET bit in the CRC\_CR register.

### 3.4.3 Control register (CRC\_CR)

Address offset: 0x08

Reset value: 0x0000 0000



Bits 31:1 **Reserved**

Bit 0 **RESET bit**

Resets the CRC calculation unit and sets the data register to FFFF FFFFh.

This bit can only be set, it is automatically cleared by hardware.

### 3.4.4 CRC register map

The following table provides the CRC register map and reset values.

**Table 8. CRC calculation unit register map and reset values**

Offset	Register	31-24	23-16	15-8	7	6	5	4	3	2	1	0	
0x00	<b>CRC_DR</b> Reset value	Data register 0xFFFF FFFF											
0x04	<b>CRC_IDR</b> Reset value	Reserved			Independent data register 0x00								
0x08	<b>CRC_CR</b> Reset value	Reserved									Reserved 0	RESET 0	

## 4 Power control (PWR)

**Low-density devices** are STM32F101xx, STM32F102xx and STM32F103xx microcontrollers where the Flash memory density ranges between 16 and 32 Kbytes.

**Medium-density devices** are STM32F101xx, STM32F102xx and STM32F103xx microcontrollers where the Flash memory density ranges between 64 and 128 Kbytes.

**High-density devices** are STM32F101xx and STM32F103xx microcontrollers where the Flash memory density ranges between 256 and 512 Kbytes.

**XL-density devices** are STM32F101xx and STM32F103xx microcontrollers where the Flash memory density ranges between 768 Kbytes and 1 Mbyte.

**Connectivity line devices** are STM32F105xx and STM32F107xx microcontrollers.

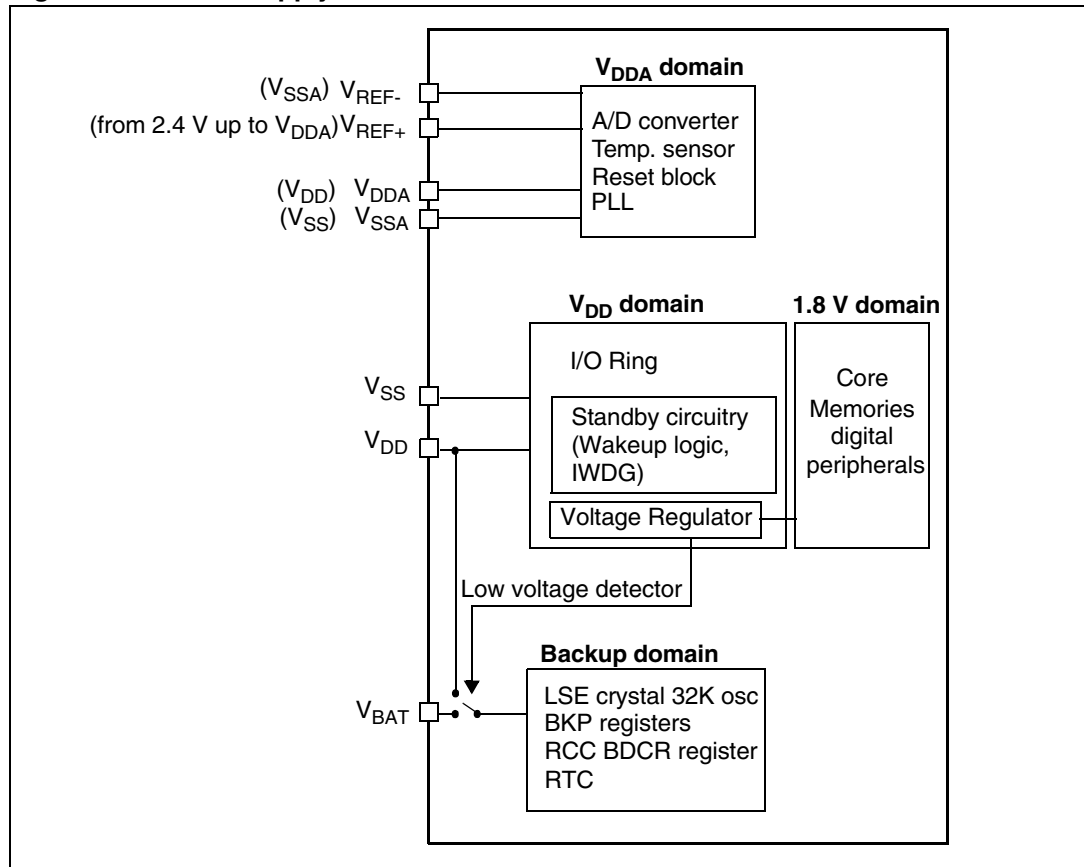
This section applies to the whole STM32F10xxx family, unless otherwise specified.

### 4.1 Power supplies

The device requires a 2.0-to-3.6 V operating voltage supply ( $V_{DD}$ ). An embedded regulator is used to supply the internal 1.8 V digital power.

The real-time clock (RTC) and backup registers can be powered from the  $V_{BAT}$  voltage when the main  $V_{DD}$  supply is powered off.

Figure 4. Power supply overview



Note: 1  $V_{DDA}$  and  $V_{SSA}$  must be connected to  $V_{DD}$  and  $V_{SS}$ , respectively.

### 4.1.1 Independent A/D converter supply and reference voltage

To improve conversion accuracy, the ADC has an independent power supply which can be separately filtered and shielded from noise on the PCB.

- The ADC voltage supply input is available on a separate  $V_{DDA}$  pin.
- An isolated supply ground connection is provided on pin  $V_{SSA}$ .

When available (according to package),  $V_{REF-}$  must be tied to  $V_{SSA}$ .

#### On 100-pin and 144-pin packages

To ensure a better accuracy on low voltage inputs, the user can connect a separate external reference voltage ADC input on  $V_{REF+}$  and  $V_{REF-}$ . The voltage on  $V_{REF+}$  can range from 2.4 V to  $V_{DDA}$ .

#### On 64-pin packages and packages with less pins

The  $V_{REF+}$  and  $V_{REF-}$  pins are not available, they are internally connected to the ADC voltage supply ( $V_{DDA}$ ) and ground ( $V_{SSA}$ ).

### 4.1.2 Battery backup domain

To retain the content of the Backup registers and supply the RTC function when  $V_{DD}$  is turned off,  $V_{BAT}$  pin can be connected to an optional standby voltage supplied by a battery or by another source.

The  $V_{BAT}$  pin powers the RTC unit, the LSE oscillator and the PC13 to PC15 IOs, allowing the RTC to operate even when the main digital supply ( $V_{DD}$ ) is turned off. The switch to the  $V_{BAT}$  supply is controlled by the Power Down Reset embedded in the Reset block.

---

**Warning:** During  $t_{RSTTEMPO}$  (temporization at  $V_{DD}$  startup) or after a PDR is detected, the power switch between  $V_{BAT}$  and  $V_{DD}$  remains connected to  $V_{BAT}$ .  
 During the startup phase, if  $V_{DD}$  is established in less than  $t_{RSTTEMPO}$  (Refer to the datasheet for the value of  $t_{RSTTEMPO}$ ) and  $V_{DD} > V_{BAT} + 0.6$  V, a current may be injected into  $V_{BAT}$  through an internal diode connected between  $V_{DD}$  and the power switch ( $V_{BAT}$ ).  
 If the power supply/battery connected to the  $V_{BAT}$  pin cannot support this current injection, it is strongly recommended to connect an external low-drop diode between this power supply and the  $V_{BAT}$  pin.

---

If no external battery is used in the application, it is recommended to connect  $V_{BAT}$  externally to  $V_{DD}$  with a 100 nF external ceramic decoupling capacitor (for more details refer to AN2586).

When the backup domain is supplied by  $V_{DD}$  (analog switch connected to  $V_{DD}$ ), the following functions are available:

- PC14 and PC15 can be used as either GPIO or LSE pins
- PC13 can be used as GPIO, TAMPER pin, RTC Calibration Clock, RTC Alarm or second output (refer to [Section 5: Backup registers \(BKP\) on page 73](#))

*Note:* Due to the fact that the switch only sinks a limited amount of current (3 mA), the use of GPIOs PC13 to PC15 in output mode is restricted: the speed has to be limited to 2 MHz with a maximum load of 30 pF and these IOs must not be used as a current source (e.g. to drive an LED).

When the backup domain is supplied by  $V_{BAT}$  (analog switch connected to  $V_{BAT}$  because  $V_{DD}$  is not present), the following functions are available:

- PC14 and PC15 can be used as LSE pins only
- PC13 can be used as TAMPER pin, RTC Alarm or Second output (refer to [Section 5.4.2: RTC clock calibration register \(BKP\\_RTCCR\) on page 75](#)).

### 4.1.3 Voltage regulator

The voltage regulator is always enabled after Reset. It works in three different modes depending on the application modes.

- In Run mode, the regulator supplies full power to the 1.8 V domain (core, memories and digital peripherals).
- In Stop mode the regulator supplies low-power to the 1.8 V domain, preserving contents of registers and SRAM
- In Standby Mode, the regulator is powered off. The contents of the registers and SRAM are lost except for the Standby circuitry and the Backup Domain.

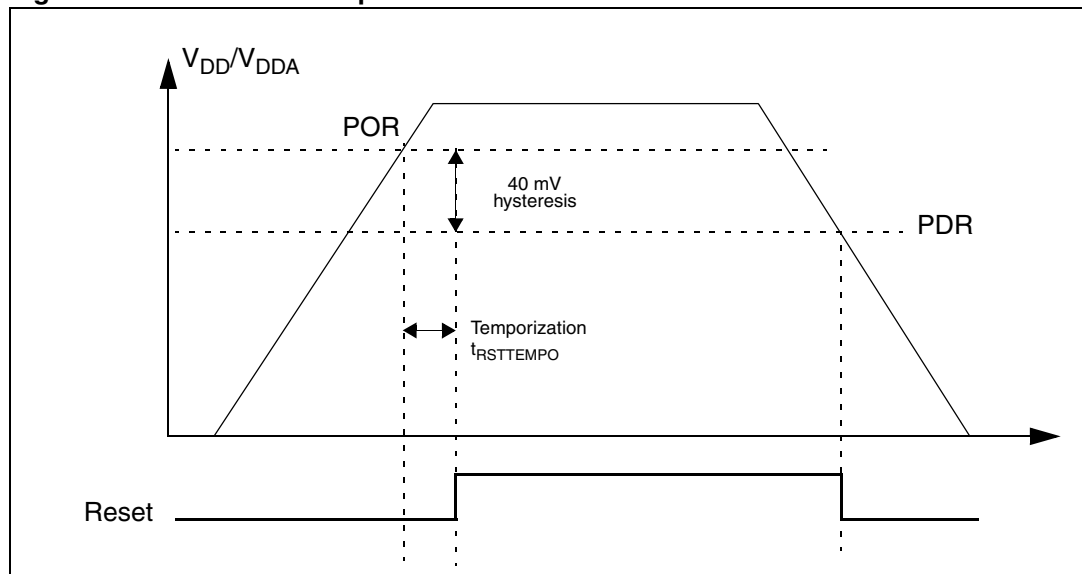
## 4.2 Power supply supervisor

### 4.2.1 Power on reset (POR)/power down reset (PDR)

The device has an integrated POR/PDR circuitry that allows proper operation starting from/down to 2 V.

The device remains in Reset mode when  $V_{DD}/V_{DDA}$  is below a specified threshold,  $V_{POR/PDR}$ , without the need for an external reset circuit. For more details concerning the power on/power down reset threshold, refer to the electrical characteristics of the datasheet.

**Figure 5. Power on reset/power down reset waveform**



### 4.2.2 Programmable voltage detector (PVD)

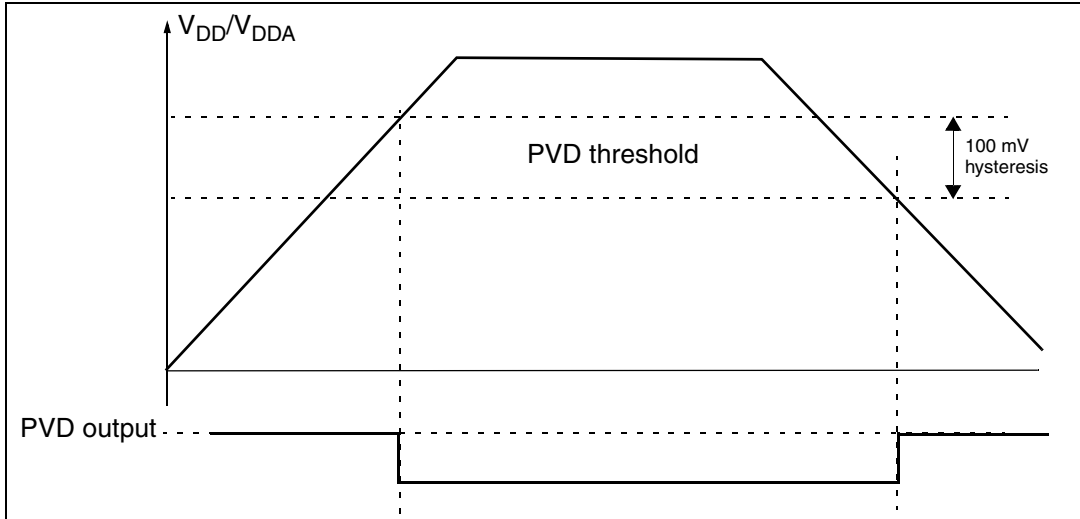
You can use the PVD to monitor the  $V_{DD}/V_{DDA}$  power supply by comparing it to a threshold selected by the PLS[2:0] bits in the [Power control register \(PWR\\_CR\)](#).

The PVD is enabled by setting the PVDE bit.

A PVDO flag is available, in the [Power control/status register \(PWR\\_CSR\)](#), to indicate if  $V_{DD}/V_{DDA}$  is higher or lower than the PVD threshold. This event is internally connected to the EXTI line16 and can generate an interrupt if enabled through the EXTI registers. The

PVD output interrupt can be generated when  $V_{DD}/V_{DDA}$  drops below the PVD threshold and/or when  $V_{DD}/V_{DDA}$  rises above the PVD threshold depending on EXTI line16 rising/falling edge configuration. As an example the service routine could perform emergency shutdown tasks.

**Figure 6. PVD thresholds**



### 4.3 Low-power modes

By default, the microcontroller is in Run mode after a system or a power Reset. Several low-power modes are available to save power when the CPU does not need to be kept running, for example when waiting for an external event. It is up to the user to select the mode that gives the best compromise between low-power consumption, short startup time and available wakeup sources.

The STM32F10xxx devices feature three low-power modes:

- Sleep mode (CPU clock off, all peripherals including Cortex-M3 core peripherals like NVIC, SysTick, etc. are kept running)
- Stop mode (all clocks are stopped)
- Standby mode (1.8V domain powered-off)

In addition, the power consumption in Run mode can be reduce by one of the following means:

- Slowing down the system clocks
- Gating the clocks to the APB and AHB peripherals when they are unused.

**Table 9. Low-power mode summary**

Mode name	Entry	wakeup	Effect on 1.8V domain clocks	Effect on V <sub>DD</sub> domain clocks	Voltage regulator
Sleep (Sleep now or Sleep-on - exit)	WFI	Any interrupt	CPU clock OFF no effect on other clocks or analog clock sources	None	ON
	WFE	Wakeup event			
Stop	PDDS and LPDS bits + SLEEPDEEP bit + WFI or WFE	Any EXTI line (configured in the EXTI registers)	All 1.8V domain clocks OFF	HSI and HSE oscillators OFF	ON or in low-power mode (depends on <a href="#">Power control register (PWR_CR)</a> )
Standby	PDDS bit + SLEEPDEEP bit + WFI or WFE	WKUP pin rising edge, RTC alarm, external reset in NRST pin, IWDG reset			OFF

#### 4.3.1 Slowing down system clocks

In Run mode the speed of the system clocks (SYSCLK, HCLK, PCLK1, PCLK2) can be reduced by programming the prescaler registers. These prescalers can also be used to slow down peripherals before entering Sleep mode.

For more details refer to [Section 6.3.2: Clock configuration register \(RCC\\_CFGR\)](#).



### 4.3.2 Peripheral clock gating

In Run mode, the HCLK and PCLKx for individual peripherals and memories can be stopped at any time to reduce power consumption.

To further reduce power consumption in Sleep mode the peripheral clocks can be disabled prior to executing the WFI or WFE instructions.

Peripheral clock gating is controlled by the *AHB peripheral clock enable register (RCC\_AHBENR)*, *APB1 peripheral clock enable register (RCC\_APB1ENR)* and *APB2 peripheral clock enable register (RCC\_APB2ENR)*.

### 4.3.3 Sleep mode

#### Entering Sleep mode

The Sleep mode is entered by executing the WFI (Wait For Interrupt) or WFE (Wait for Event) instructions. Two options are available to select the Sleep mode entry mechanism, depending on the SLEEPONEXIT bit in the Cortex-M3 System Control register:

- Sleep-now: if the SLEEPONEXIT bit is cleared, the MCU enters Sleep mode as soon as WFI or WFE instruction is executed.
- Sleep-on-exit: if the SLEEPONEXIT bit is set, the MCU enters Sleep mode as soon as it exits the lowest priority ISR.

In the Sleep mode, all I/O pins keep the same state as in the Run mode.

Refer to [Table 10](#) and [Table 11](#) for details on how to enter Sleep mode.

#### Exiting Sleep mode

If the WFI instruction is used to enter Sleep mode, any peripheral interrupt acknowledged by the nested vectored interrupt controller (NVIC) can wake up the device from Sleep mode.

If the WFE instruction is used to enter Sleep mode, the MCU exits Sleep mode as soon as an event occurs. The wakeup event can be generated either by:

- enabling an interrupt in the peripheral control register but not in the NVIC, and enabling the SEVONPEND bit in the Cortex-M3 System Control register. When the MCU resumes from WFE, the peripheral interrupt pending bit and the peripheral NVIC IRQ channel pending bit (in the NVIC interrupt clear pending register) have to be cleared.
- or configuring an external or internal EXTI line in event mode. When the CPU resumes from WFE, it is not necessary to clear the peripheral interrupt pending bit or the NVIC IRQ channel pending bit as the pending bit corresponding to the event line is not set.

This mode offers the lowest wakeup time as no time is wasted in interrupt entry/exit.

Refer to [Table 10](#) and [Table 11](#) for more details on how to exit Sleep mode.

Table 10. Sleep-now

Sleep-now mode	Description
Mode entry	WFI (Wait for Interrupt) or WFE (Wait for Event) while: <ul style="list-style-type: none"> <li>– SLEEPDEEP = 0 and</li> <li>– SLEEPONEXIT = 0</li> </ul> Refer to the Cortex™-M3 System Control register.
Mode exit	If WFI was used for entry: Interrupt: Refer to <a href="#">Table 61: Vector table for other STM32F10xxx devices</a> If WFE was used for entry: Wakeup event: Refer to <a href="#">Section 9.2.3: Wakeup event management</a>
Wakeup latency	None

Table 11. Sleep-on-exit

Sleep-on-exit	Description
Mode entry	WFI (wait for interrupt) while: <ul style="list-style-type: none"> <li>– SLEEPDEEP = 0 and</li> <li>– SLEEPONEXIT = 1</li> </ul> Refer to the Cortex™-M3 System Control register.
Mode exit	Interrupt: refer to <a href="#">Table 61: Vector table for other STM32F10xxx devices</a> .
Wakeup latency	None

#### 4.3.4 Stop mode

The Stop mode is based on the Cortex-M3 deepsleep mode combined with peripheral clock gating. The voltage regulator can be configured either in normal or low-power mode. In Stop mode, all clocks in the 1.8 V domain are stopped, the PLL, the HSI and the HSE RC oscillators are disabled. SRAM and register contents are preserved.

In the Stop mode, all I/O pins keep the same state as in the Run mode.

##### Entering Stop mode

Refer to [Table 12](#) for details on how to enter the Stop mode.

To further reduce power consumption in Stop mode, the internal voltage regulator can be put in low-power mode. This is configured by the LPDS bit of the [Power control register \(PWR\\_CR\)](#).

If Flash memory programming is ongoing, the Stop mode entry is delayed until the memory access is finished.

If an access to the APB domain is ongoing, The Stop mode entry is delayed until the APB access is finished.

In Stop mode, the following features can be selected by programming individual control bits:

- Independent watchdog (IWDG): the IWDG is started by writing to its Key register or by hardware option. Once started it cannot be stopped except by a Reset. See [Section 18.3: IWDG functional description](#) in [Section 18: Independent watchdog \(IWDG\)](#).

- real-time clock (RTC): this is configured by the RTCEN bit in the [Backup domain control register \(RCC\\_BDCR\)](#)
- Internal RC oscillator (LSI RC): this is configured by the LSION bit in the [Control/status register \(RCC\\_CSR\)](#).
- External 32.768 kHz oscillator (LSE OSC): this is configured by the LSEON bit in the [Backup domain control register \(RCC\\_BDCR\)](#).

The ADC or DAC can also consume power during the Stop mode, unless they are disabled before entering it. To disable them, the ADON bit in the ADC\_CR2 register and the ENx bit in the DAC\_CR register must both be written to 0.

### Exiting Stop mode

Refer to [Table 12](#) for more details on how to exit Stop mode.

When exiting Stop mode by issuing an interrupt or a wakeup event, the HSI RC oscillator is selected as system clock.

When the voltage regulator operates in low-power mode, an additional startup delay is incurred when waking up from Stop mode. By keeping the internal regulator ON during Stop mode, the consumption is higher although the startup time is reduced.

**Table 12. Stop mode**

Stop mode	Description
<b>Mode entry</b>	<p>WFI (Wait for Interrupt) or WFE (Wait for Event) while:</p> <ul style="list-style-type: none"> <li>– Set SLEEPDEEP bit in Cortex™-M3 System Control register</li> <li>– Clear PDDS bit in Power Control register (PWR_CR)</li> <li>– Select the voltage regulator mode by configuring LPDS bit in PWR_CR</li> </ul> <p><b>Note:</b> To enter Stop mode, all EXTI Line pending bits (in <a href="#">Pending register (EXTI_PR)</a>) and RTC Alarm flag must be reset. Otherwise, the Stop mode entry procedure is ignored and program execution continues.</p>
<b>Mode exit</b>	<p>If WFI was used for entry:</p> <p>Any EXTI Line configured in Interrupt mode (the corresponding EXTI Interrupt vector must be enabled in the NVIC). Refer to <a href="#">Table 61: Vector table for other STM32F10xxx devices on page 187</a>.</p> <p>If WFE was used for entry:</p> <p>Any EXTI Line configured in event mode. Refer to <a href="#">Section 9.2.3: Wakeup event management on page 190</a></p>
<b>Wakeup latency</b>	HSI RC wakeup time + regulator wakeup time from Low-power mode

### 4.3.5 Standby mode

The Standby mode allows to achieve the lowest power consumption. It is based on the Cortex-M3 deepsleep mode, with the voltage regulator disabled. The 1.8 V domain is consequently powered off. The PLL, the HSI oscillator and the HSE oscillator are also switched off. SRAM and register contents are lost except for registers in the Backup domain and Standby circuitry (see [Figure 4](#)).

## Entering Standby mode

Refer to [Table 13](#) for more details on how to enter Standby mode.

In Standby mode, the following features can be selected by programming individual control bits:

- Independent watchdog (IWDG): the IWDG is started by writing to its Key register or by hardware option. Once started it cannot be stopped except by a reset. See [Section 18.3: IWDG functional description](#) in [Section 18: Independent watchdog \(IWDG\)](#).
- real-time clock (RTC): this is configured by the RTCEN bit in the Backup domain control register (RCC\_BDCR)
- Internal RC oscillator (LSI RC): this is configured by the LSION bit in the Control/status register (RCC\_CSR).
- External 32.768 kHz oscillator (LSE OSC): this is configured by the LSEON bit in the Backup domain control register (RCC\_BDCR)

## Exiting Standby mode

The microcontroller exits the Standby mode when an external reset (NRST pin), an IWDG reset, a rising edge on the WKUP pin or the rising edge of an RTC alarm occurs (see [Figure 179: RTC simplified block diagram](#)). All registers are reset after wakeup from Standby except for [Power control/status register \(PWR\\_CSR\)](#).

After waking up from Standby mode, program execution restarts in the same way as after a Reset (boot pins sampling, vector reset is fetched, etc.). The SBF status flag in the [Power control/status register \(PWR\\_CSR\)](#) indicates that the MCU was in Standby mode.

Refer to [Table 13](#) for more details on how to exit Standby mode.

**Table 13. Standby mode**

Standby mode	Description
<b>Mode entry</b>	WFI (Wait for Interrupt) or WFE (Wait for Event) while: <ul style="list-style-type: none"> <li>– Set SLEEPDEEP in Cortex™-M3 System Control register</li> <li>– Set PDDS bit in Power Control register (PWR_CR)</li> <li>– Clear WUF bit in Power Control/Status register (PWR_CSR)</li> </ul>
<b>Mode exit</b>	WKUP pin rising edge, RTC alarm event's rising edge, external Reset in NRST pin, IWDG Reset.
<b>Wakeup latency</b>	Regulator startup. Reset phase

## I/O states in Standby mode

In Standby mode, all I/O pins are high impedance except:

- Reset pad (still available)
- TAMPER pin if configured for tamper or calibration out
- WKUP pin, if enabled

### Debug mode

By default, the debug connection is lost if the application puts the MCU in Stop or Standby mode while the debug features are used. This is due to the fact that the Cortex™-M3 core is no longer clocked.

However, by setting some configuration bits in the DBGMCU\_CR register, the software can be debugged even when using the low-power modes extensively. For more details, refer to [Section 30.16.1: Debug support for low-power modes](#).

### 4.3.6 Auto-wakeup (AWU) from low-power mode

The RTC can be used to wakeup the MCU from low-power mode without depending on an external interrupt (Auto-wakeup mode). The RTC provides a programmable time base for waking up from Stop or Standby mode at regular intervals. For this purpose, two of the three alternative RTC clock sources can be selected by programming the RTCSEL[1:0] bits in the [Backup domain control register \(RCC\\_BDCR\)](#):

- Low-power 32.768 kHz external crystal oscillator (LSE OSC).  
This clock source provides a precise time base with very low-power consumption (less than 1µA added consumption in typical conditions)
- Low-power internal RC Oscillator (LSI RC)  
This clock source has the advantage of saving the cost of the 32.768 kHz crystal. This internal RC Oscillator is designed to add minimum power consumption.

To wakeup from Stop mode with an RTC alarm event, it is necessary to:

- Configure the EXTI Line 17 to be sensitive to rising edge
- Configure the RTC to generate the RTC alarm

To wakeup from Standby mode, there is no need to configure the EXTI Line 17.

## 4.4 Power control registers

The peripheral registers can be accessed by half-words (16-bit) or words (32-bit).

### 4.4.1 Power control register (PWR\_CR)

Address offset: 0x00

Reset value: 0x0000 0000 (reset by wakeup from Standby mode)

31	30	29	28	27	26	25	24	23	22	21	20	19	18	17	16
Reserved															
15	14	13	12	11	10	9	8	7	6	5	4	3	2	1	0
Reserved							DBP	PLS[2:0]			PVDE	CSBF	CWUF	PDDS	LPDS
							rw	rw	rw	rw	rw	rc_w1	rc_w1	rw	rw

Bits 31:9 Reserved, always read as 0.

Bit 8 **DBP**: Disable backup domain write protection.

In reset state, the RTC and backup registers are protected against parasitic write access.

This bit must be set to enable write access to these registers.

0: Access to RTC and Backup registers disabled

1: Access to RTC and Backup registers enabled

*Note: If the HSE divided by 128 is used as the RTC clock, this bit must remain set to 1.*

Bits 7:5 **PLS[2:0]**: PVD level selection.

These bits are written by software to select the voltage threshold detected by the Power Voltage Detector

000: 2.2V

001: 2.3V

010: 2.4V

011: 2.5V

100: 2.6V

101: 2.7V

110: 2.8V

111: 2.9V

*Note: Refer to the electrical characteristics of the datasheet for more details.*

Bit 4 **PVDE**: Power voltage detector enable.

This bit is set and cleared by software.

0: PVD disabled

1: PVD enabled

Bit 3 **CSBF**: Clear standby flag.

This bit is always read as 0.

0: No effect

1: Clear the SBF Standby Flag (write).

Bit 2 **CWUF**: Clear wakeup flag.

This bit is always read as 0.

0: No effect

1: Clear the WUF Wakeup Flag **after 2 System clock cycles.** (write)

Bit 1 **PDDS**: Power down deepsleep.

This bit is set and cleared by software. It works together with the LPDS bit.

0: Enter Stop mode when the CPU enters Deepsleep. The regulator status depends on the LPDS bit.

1: Enter Standby mode when the CPU enters Deepsleep.

Bit 0 **LPDS**: Low-power deepsleep.

This bit is set and cleared by software. It works together with the PDDS bit.

0: Voltage regulator on during Stop mode

1: Voltage regulator in low-power mode during Stop mode

### 4.4.2 Power control/status register (PWR\_CSR)

Address offset: 0x04

Reset value: 0x0000 0000 (not reset by wakeup from Standby mode)

Additional APB cycles are needed to read this register versus a standard APB read.

31	30	29	28	27	26	25	24	23	22	21	20	19	18	17	16
Reserved															
15	14	13	12	11	10	9	8	7	6	5	4	3	2	1	0
Reserved							EWUP	Reserved					PVDO	SBF	WUF
							rw						r	r	r

Bits 31:9 Reserved, always read as 0.

Bit 8 **EWUP**: Enable WKUP pin

This bit is set and cleared by software.

0: WKUP pin is used for general purpose I/O. An event on the WKUP pin does not wakeup the device from Standby mode.

1: WKUP pin is used for wakeup from Standby mode and forced in input pull down configuration (rising edge on WKUP pin wakes-up the system from Standby mode).

*Note: This bit is reset by a system Reset.*

Bits 7:3 Reserved, always read as 0.

Bit 2 **PVDO**: PVD output

This bit is set and cleared by hardware. It is valid only if PVD is enabled by the PVDE bit.

0:  $V_{DD}/V_{DDA}$  is higher than the PVD threshold selected with the PLS[2:0] bits.

1:  $V_{DD}/V_{DDA}$  is lower than the PVD threshold selected with the PLS[2:0] bits.

*Note: The PVD is stopped by Standby mode. For this reason, this bit is equal to 0 after Standby or reset until the PVDE bit is set.*

Bit 1 **SBF**: Standby flag

This bit is set by hardware and cleared only by a POR/PDR (power on reset/power down reset) or by setting the CSBF bit in the [Power control register \(PWR\\_CR\)](#)

0: Device has not been in Standby mode

1: Device has been in Standby mode

Bit 0 **WUF**: Wakeup flag

This bit is set by hardware and cleared only by a POR/PDR (power on reset/power down reset) or by setting the CWUF bit in the [Power control register \(PWR\\_CR\)](#)

0: No wakeup event occurred

1: A wakeup event was received from the WKUP pin or from the RTC alarm

*Note: An additional wakeup event is detected if the WKUP pin is enabled (by setting the EWUP bit) when the WKUP pin level is already high.*

### 4.4.3 PWR register map

The following table summarizes the PWR registers.

**Table 14. PWR register map and reset values**

Offset	Register	31	30	29	28	27	26	25	24	23	22	21	20	19	18	17	16	15	14	13	12	11	10	9	8	7	6	5	4	3	2	1	0											
0x000	PWR_CR	Reserved																							DBP	PLS[2:0]			PVDE	CSBF	CWUF	PDDS	LPDS											
	Reset value																								0	0	0	0	0	0	0	0	0											
0x004	PWR_CSR	Reserved																							EWUP	Reserved														PVDO	SBF	WUF		
	Reset value																								0															0	0	0		

Refer to [Table 1 on page 44](#) for the register boundary addresses.



## 5 Backup registers (BKP)

**Low-density devices** are STM32F101xx, STM32F102xx and STM32F103xx microcontrollers where the Flash memory density ranges between 16 and 32 Kbytes.

**Medium-density devices** are STM32F101xx, STM32F102xx and STM32F103xx microcontrollers where the Flash memory density ranges between 64 and 128 Kbytes.

**High-density devices** are STM32F101xx and STM32F103xx microcontrollers where the Flash memory density ranges between 256 and 512 Kbytes.

**XL-density devices** are STM32F101xx and STM32F103xx microcontrollers where the Flash memory density ranges between 768 Kbytes and 1 Mbyte.

**Connectivity line devices** are STM32F105xx and STM32F107xx microcontrollers.

This section applies to the whole STM32F10xxx family, unless otherwise specified.

### 5.1 BKP introduction

The backup registers are forty two 16-bit registers for storing 84 bytes of user application data. They are implemented in the backup domain that remains powered on by  $V_{BAT}$  when the  $V_{DD}$  power is switched off. They are not reset when the device wakes up from Standby mode or by a system reset or power reset.

In addition, the BKP control registers are used to manage the Tamper detection feature and RTC calibration.

After reset, access to the Backup registers and RTC is disabled and the Backup domain (BKP) is protected against possible parasitic write access. To enable access to the Backup registers and the RTC, proceed as follows:

- enable the power and backup interface clocks by setting the PWREN and BKPEN bits in the RCC\_APB1ENR register
- set the DBP bit the Power Control Register (PWR\_CR) to enable access to the Backup registers and RTC.

### 5.2 BKP main features

- 20-byte data registers (in medium-density and low-density devices) or 84-byte data registers (in high-density, XL-density and connectivity line devices)
- Status/control register for managing tamper detection with interrupt capability
- Calibration register for storing the RTC calibration value
- Possibility to output the RTC Calibration Clock, RTC Alarm pulse or Second pulse on TAMPER pin PC13 (when this pin is not used for tamper detection)

## 5.3 BKP functional description

### 5.3.1 Tamper detection

The TAMPER pin generates a Tamper detection event when the pin changes from 0 to 1 or from 1 to 0 depending on the TPAL bit in the [Backup control register \(BKP\\_CR\)](#). A tamper detection event resets all data backup registers.

However to avoid losing Tamper events, the signal used for edge detection is logically ANDed with the Tamper enable in order to detect a Tamper event in case it occurs before the TAMPER pin is enabled.

- **When TPAL=0:** If the TAMPER pin is already high before it is enabled (by setting TPE bit), an extra Tamper event is detected as soon as the TAMPER pin is enabled (while there was no rising edge on the TAMPER pin after TPE was set)
- **When TPAL=1:** If the TAMPER pin is already low before it is enabled (by setting the TPE bit), an extra Tamper event is detected as soon as the TAMPER pin is enabled (while there was no falling edge on the TAMPER pin after TPE was set)

By setting the TPIE bit in the BKP\_CSR register, an interrupt is generated when a Tamper detection event occurs.

After a Tamper event has been detected and cleared, the TAMPER pin should be disabled and then re-enabled with TPE before writing to the backup data registers (BKP\_DRx) again. This prevents software from writing to the backup data registers (BKP\_DRx), while the TAMPER pin value still indicates a Tamper detection. This is equivalent to a level detection on the TAMPER pin.

*Note: Tamper detection is still active when  $V_{DD}$  power is switched off. To avoid unwanted resetting of the data backup registers, the TAMPER pin should be externally tied to the correct level.*

### 5.3.2 RTC calibration

For measurement purposes, the RTC clock with a frequency divided by 64 can be output on the TAMPER pin. This is enabled by setting the CCO bit in the [RTC clock calibration register \(BKP\\_RTCCR\)](#).

The clock can be slowed down by up to 121 ppm by configuring CAL[6:0] bits.

For more details about RTC calibration and how to use it to improve timekeeping accuracy, please refer to AN2604 "STM32F101xx and STM32F103xx RTC calibration".

## 5.4 BKP registers

Refer to [Section 1.1 on page 40](#) for a list of abbreviations used in register descriptions.

The peripheral registers can be accessed by half-words (16-bit) or words (32-bit).

### 5.4.1 Backup data register x (BKP\_DRx) (x = 1 ..42)

Address offset: 0x04 to 0x28, 0x40 to 0xBC

Reset value: 0x0000 0000

15	14	13	12	11	10	9	8	7	6	5	4	3	2	1	0
D[15:0]															
rw	rw	rw	rw	rw	rw	rw	rw	rw	rw	rw	rw	rw	rw	rw	rw

Bits 15:0 **D[15:0]** Backup data

These bits can be written with user data.

*Note: The BKP\_DRx registers are not reset by a System reset or Power reset or when the device wakes up from Standby mode.*

*They are reset by a Backup Domain reset or by a TAMPER pin event (if the TAMPER pin function is activated).*

### 5.4.2 RTC clock calibration register (BKP\_RTCCR)

Address offset: 0x2C

Reset value: 0x0000 0000

15	14	13	12	11	10	9	8	7	6	5	4	3	2	1	0
Reserved						ASOS	ASOE	CCO	CAL[6:0]						
						rw	rw	rw	rw	rw	rw	rw	rw	rw	rw

Bits 15:10 Reserved, always read as 0.

Bit 9 **ASOS**: Alarm or second output selection

When the ASOE bit is set, the ASOS bit can be used to select whether the signal output on the TAMPER pin is the RTC Second pulse signal or the Alarm pulse signal:

0: RTC Alarm pulse output selected

1: RTC Second pulse output selected

*Note: This bit is reset only by a Backup domain reset.*

Bit 8 **ASOE**: Alarm or second output enable

Setting this bit outputs either the RTC Alarm pulse signal or the Second pulse signal on the TAMPER pin depending on the ASOS bit.

The output pulse duration is one RTC clock period. The TAMPER pin must not be enabled while the ASOE bit is set.

*Note: This bit is reset only by a Backup domain reset.*

Bit 7 **CCO**: Calibration clock output

0: No effect

1: Setting this bit outputs the RTC clock with a frequency divided by 64 on the TAMPER pin. The TAMPER pin must not be enabled while the CCO bit is set in order to avoid unwanted Tamper detection.

*Note: This bit is reset when the V<sub>DD</sub> supply is powered off.*

Bit 6:0 **CAL[6:0]**: Calibration value

This value indicates the number of clock pulses that will be ignored every 2<sup>20</sup> clock pulses. This allows the calibration of the RTC, slowing down the clock by steps of 1000000/2<sup>20</sup> PPM. The clock of the RTC can be slowed down from 0 to 121PPM.

### 5.4.3 Backup control register (BKP\_CR)

Address offset: 0x30

Reset value: 0x0000 0000

15	14	13	12	11	10	9	8	7	6	5	4	3	2	1	0
Reserved													TPAL	TPE	
													rw	rw	

Bits 15:2 Reserved, always read as 0.

Bit 1 **TPAL**: TAMPER pin active level

0: A high level on the TAMPER pin resets all data backup registers (if TPE bit is set).  
 1: A low level on the TAMPER pin resets all data backup registers (if TPE bit is set).

Bit 0 **TPE**: TAMPER pin enable

0: The TAMPER pin is free for general purpose I/O  
 1: Tamper alternate I/O function is activated.

*Note: Setting the TPAL and TPE bits at the same time is always safe, however resetting both at the same time can generate a spurious Tamper event. For this reason it is recommended to change the TPAL bit only when the TPE bit is reset.*

### 5.4.4 Backup control/status register (BKP\_CSR)

Address offset: 0x34

Reset value: 0x0000 0000

15	14	13	12	11	10	9	8	7	6	5	4	3	2	1	0
Reserved						TIF	TEF	Reserved					TPIE	CTI	CTE
						r	r						rw	w	w

Bits 15:10 Reserved, always read as 0.

Bit 9 **TIF**: Tamper interrupt flag

This bit is set by hardware when a Tamper event is detected and the TPIE bit is set. It is cleared by writing 1 to the CTI bit (also clears the interrupt). It is also cleared if the TPIE bit is reset.

0: No Tamper interrupt  
 1: A Tamper interrupt occurred

*Note: This bit is reset only by a system reset and wakeup from Standby mode.*

Bit 8 **TEF**: Tamper event flag

This bit is set by hardware when a Tamper event is detected. It is cleared by writing 1 to the CTE bit.

- 0: No Tamper event
- 1: A Tamper event occurred

*Note: A Tamper event resets all the BKP\_DRx registers. They are held in reset as long as the TEF bit is set. If a write to the BKP\_DRx registers is performed while this bit is set, the value will not be stored.*

Bits 7:3 Reserved, always read as 0.

Bit 2 **TIPE**: TAMPER pin interrupt enable

- 0: Tamper interrupt disabled
- 1: Tamper interrupt enabled (the TPE bit must also be set in the BKP\_CR register)

*Note: 1: A Tamper interrupt does not wake up the core from low-power modes.  
2: This bit is reset only by a system reset and wakeup from Standby mode.*

Bit 1 **CTI**: Clear tamper interrupt

This bit is write only, and is always read as 0.

- 0: No effect
- 1: Clear the Tamper interrupt and the TIF Tamper interrupt flag.

Bit 0 **CTE**: Clear tamper event

This bit is write only, and is always read as 0.

- 0: No effect
- 1: Reset the TEF Tamper event flag (and the Tamper detector)

### 5.4.5 BKP register map

BKP registers are mapped as 16-bit addressable registers as described in the table below:

**Table 15. BKP register map and reset values**

Offset	Register	31	30	29	28	27	26	25	24	23	22	21	20	19	18	17	16	15	14	13	12	11	10	9	8	7	6	5	4	3	2	1	0
0x00	Reserved																																
0x04	<b>BKP_DR1</b>	Reserved																D[15:0]															
	Reset value	0 0																															
0x08	<b>BKP_DR2</b>	Reserved																D[15:0]															
	Reset value	0 0																															
0x0C	<b>BKP_DR3</b>	Reserved																D[15:0]															
	Reset value	0 0																															
0x10	<b>BKP_DR4</b>	Reserved																D[15:0]															
	Reset value	0 0																															
0x14	<b>BKP_DR5</b>	Reserved																D[15:0]															
	Reset value	0 0																															
0x18	<b>BKP_DR6</b>	Reserved																D[15:0]															
	Reset value	0 0																															

Table 15. BKP register map and reset values (continued)

Offset	Register	31	30	29	28	27	26	25	24	23	22	21	20	19	18	17	16	15	14	13	12	11	10	9	8	7	6	5	4	3	2	1	0																
0x1C	BKP_DR7	Reserved																D[15:0]																															
	Reset value																	0	0	0	0	0	0	0	0	0	0	0	0	0	0	0	0	0	0	0	0	0	0	0	0	0	0	0	0	0	0	0	0
0x20	BKP_DR8	Reserved																D[15:0]																															
	Reset value																	0	0	0	0	0	0	0	0	0	0	0	0	0	0	0	0	0	0	0	0	0	0	0	0	0	0	0	0	0	0	0	0
0x24	BKP_DR9	Reserved																D[15:0]																															
	Reset value																	0	0	0	0	0	0	0	0	0	0	0	0	0	0	0	0	0	0	0	0	0	0	0	0	0	0	0	0	0	0	0	0
0x28	BKP_DR10	Reserved																D[15:0]																															
	Reset value																	0	0	0	0	0	0	0	0	0	0	0	0	0	0	0	0	0	0	0	0	0	0	0	0	0	0	0	0	0	0	0	0
0x2	BKP_RTCCR	Reserved																ASOS	ASOE	CCO	CAL[6:0]																												
	Reset value																	0	0	0	0	0	0	0	0	0	0	0	0	0	0	0	0	0	0	0	0	0	0	0	0	0	0	0	0	0	0	0	0
0x30	BKP_CR	Reserved																												TPAL	TPE																		
	Reset value																													0	0																		
0x34	BKP_CSR	Reserved																TIF	TEF	Reserved												TPIE	CTI	CTE															
	Reset value																	0	0													0	0	0															
0x38	Reserved																																																
0x3C	Reserved																																																
0x40	BKP_DR11	Reserved																D[15:0]																															
	Reset value																	0	0	0	0	0	0	0	0	0	0	0	0	0	0	0	0	0	0	0	0	0	0	0	0	0	0	0	0	0	0	0	0
0x44	BKP_DR12	Reserved																D[15:0]																															
	Reset value																	0	0	0	0	0	0	0	0	0	0	0	0	0	0	0	0	0	0	0	0	0	0	0	0	0	0	0	0	0	0	0	0
0x48	BKP_DR13	Reserved																D[15:0]																															
	Reset value																	0	0	0	0	0	0	0	0	0	0	0	0	0	0	0	0	0	0	0	0	0	0	0	0	0	0	0	0	0	0	0	0
0x4C	BKP_DR14	Reserved																D[15:0]																															
	Reset value																	0	0	0	0	0	0	0	0	0	0	0	0	0	0	0	0	0	0	0	0	0	0	0	0	0	0	0	0	0	0	0	0
0x50	BKP_DR15	Reserved																D[15:0]																															
	Reset value																	0	0	0	0	0	0	0	0	0	0	0	0	0	0	0	0	0	0	0	0	0	0	0	0	0	0	0	0	0	0	0	0
0x54	BKP_DR16	Reserved																D[15:0]																															
	Reset value																	0	0	0	0	0	0	0	0	0	0	0	0	0	0	0	0	0	0	0	0	0	0	0	0	0	0	0	0	0	0	0	0
0x58	BKP_DR17	Reserved																D[15:0]																															
	Reset value																	0	0	0	0	0	0	0	0	0	0	0	0	0	0	0	0	0	0	0	0	0	0	0	0	0	0	0	0	0	0	0	0
0x5C	BKP_DR18	Reserved																D[15:0]																															
	Reset value																	0	0	0	0	0	0	0	0	0	0	0	0	0	0	0	0	0	0	0	0	0	0	0	0	0	0	0	0	0	0	0	0
0x60	BKP_DR19	Reserved																D[15:0]																															
	Reset value																	0	0	0	0	0	0	0	0	0	0	0	0	0	0	0	0	0	0	0	0	0	0	0	0	0	0	0	0	0	0	0	0



Table 15. BKP register map and reset values (continued)

Offset	Register	31	30	29	28	27	26	25	24	23	22	21	20	19	18	17	16	15	14	13	12	11	10	9	8	7	6	5	4	3	2	1	0																
0x64	BKP_DR20	Reserved																D[15:0]																															
	Reset value																	0	0	0	0	0	0	0	0	0	0	0	0	0	0	0	0	0	0	0	0	0	0	0	0	0	0	0	0	0	0	0	0
0x68	BKP_DR21	Reserved																D[15:0]																															
	Reset value																	0	0	0	0	0	0	0	0	0	0	0	0	0	0	0	0	0	0	0	0	0	0	0	0	0	0	0	0	0	0	0	0
0x6C	BKP_DR22	Reserved																D[15:0]																															
	Reset value																	0	0	0	0	0	0	0	0	0	0	0	0	0	0	0	0	0	0	0	0	0	0	0	0	0	0	0	0	0	0	0	0
0x70	BKP_DR23	Reserved																D[15:0]																															
	Reset value																	0	0	0	0	0	0	0	0	0	0	0	0	0	0	0	0	0	0	0	0	0	0	0	0	0	0	0	0	0	0	0	0
0x74	BKP_DR24	Reserved																D[15:0]																															
	Reset value																	0	0	0	0	0	0	0	0	0	0	0	0	0	0	0	0	0	0	0	0	0	0	0	0	0	0	0	0	0	0	0	0
0x78	BKP_DR25	Reserved																D[15:0]																															
	Reset value																	0	0	0	0	0	0	0	0	0	0	0	0	0	0	0	0	0	0	0	0	0	0	0	0	0	0	0	0	0	0	0	0
0x7C	BKP_DR26	Reserved																D[15:0]																															
	Reset value																	0	0	0	0	0	0	0	0	0	0	0	0	0	0	0	0	0	0	0	0	0	0	0	0	0	0	0	0	0	0	0	0
0x80	BKP_DR27	Reserved																D[15:0]																															
	Reset value																	0	0	0	0	0	0	0	0	0	0	0	0	0	0	0	0	0	0	0	0	0	0	0	0	0	0	0	0	0	0	0	0
0x84	BKP_DR28	Reserved																D[15:0]																															
	Reset value																	0	0	0	0	0	0	0	0	0	0	0	0	0	0	0	0	0	0	0	0	0	0	0	0	0	0	0	0	0	0	0	0
0x88	BKP_DR29	Reserved																D[15:0]																															
	Reset value																	0	0	0	0	0	0	0	0	0	0	0	0	0	0	0	0	0	0	0	0	0	0	0	0	0	0	0	0	0	0	0	0
0x8C	BKP_DR30	Reserved																D[15:0]																															
	Reset value																	0	0	0	0	0	0	0	0	0	0	0	0	0	0	0	0	0	0	0	0	0	0	0	0	0	0	0	0	0	0	0	0
0x90	BKP_DR31	Reserved																D[15:0]																															
	Reset value																	0	0	0	0	0	0	0	0	0	0	0	0	0	0	0	0	0	0	0	0	0	0	0	0	0	0	0	0	0	0	0	0
0x94	BKP_DR32	Reserved																D[15:0]																															
	Reset value																	0	0	0	0	0	0	0	0	0	0	0	0	0	0	0	0	0	0	0	0	0	0	0	0	0	0	0	0	0	0	0	0
0x98	BKP_DR33	Reserved																D[15:0]																															
	Reset value																	0	0	0	0	0	0	0	0	0	0	0	0	0	0	0	0	0	0	0	0	0	0	0	0	0	0	0	0	0	0	0	0
0x9C	BKP_DR34	Reserved																D[15:0]																															
	Reset value																	0	0	0	0	0	0	0	0	0	0	0	0	0	0	0	0	0	0	0	0	0	0	0	0	0	0	0	0	0	0	0	0
0xA0	BKP_DR35	Reserved																D[15:0]																															
	Reset value																	0	0	0	0	0	0	0	0	0	0	0	0	0	0	0	0	0	0	0	0	0	0	0	0	0	0	0	0	0	0	0	0
0xA4	BKP_DR36	Reserved																D[15:0]																															
	Reset value																	0	0	0	0	0	0	0	0	0	0	0	0	0	0	0	0	0	0	0	0	0	0	0	0	0	0	0	0	0	0	0	0

**Table 15. BKP register map and reset values (continued)**

Offset	Register	31	30	29	28	27	26	25	24	23	22	21	20	19	18	17	16	15	14	13	12	11	10	9	8	7	6	5	4	3	2	1	0																	
0xA8	<b>BKP_DR37</b>	Reserved																D[15:0]																																
	Reset value																	0	0	0	0	0	0	0	0	0	0	0	0	0	0	0	0	0	0	0	0	0	0	0	0	0	0	0	0	0	0	0	0	0
0xAC	<b>BKP_DR38</b>	Reserved																D[15:0]																																
	Reset value																	0	0	0	0	0	0	0	0	0	0	0	0	0	0	0	0	0	0	0	0	0	0	0	0	0	0	0	0	0	0	0	0	0
0xB0	<b>BKP_DR39</b>	Reserved																D[15:0]																																
	Reset value																	0	0	0	0	0	0	0	0	0	0	0	0	0	0	0	0	0	0	0	0	0	0	0	0	0	0	0	0	0	0	0	0	0
0xB4	<b>BKP_DR40</b>	Reserved																D[15:0]																																
	Reset value																	0	0	0	0	0	0	0	0	0	0	0	0	0	0	0	0	0	0	0	0	0	0	0	0	0	0	0	0	0	0	0	0	0
0xB8	<b>BKP_DR41</b>	Reserved																D[15:0]																																
	Reset value																	0	0	0	0	0	0	0	0	0	0	0	0	0	0	0	0	0	0	0	0	0	0	0	0	0	0	0	0	0	0	0	0	0
0xBC	<b>BKP_DR42</b>	Reserved																D[15:0]																																
	Reset value																	0	0	0	0	0	0	0	0	0	0	0	0	0	0	0	0	0	0	0	0	0	0	0	0	0	0	0	0	0	0	0	0	0

Refer to [Table 1 on page 44](#) for the register boundary addresses.



## 6 Low-, medium-, high- and XL-density reset and clock control (RCC)

**Low-density devices** are STM32F101xx, STM32F102xx and STM32F103xx microcontrollers where the Flash memory density ranges between 16 and 32 Kbytes.

**Medium-density devices** are STM32F101xx, STM32F102xx and STM32F103xx microcontrollers where the Flash memory density ranges between 64 and 128 Kbytes.

**High-density devices** are STM32F101xx and STM32F103xx microcontrollers where the Flash memory density ranges between 256 and 512 Kbytes.

**XL-density devices** are STM32F101xx and STM32F103xx microcontrollers where the Flash memory density ranges between 768 Kbytes and 1 Mbyte.

**Connectivity line devices** are STM32F105xx and STM32F107xx microcontrollers.

This Section applies to low-, medium-, high- and XL-density STM32F10xxx devices. Connectivity line devices are discussed in a separate section (refer to [Connectivity line devices: reset and clock control \(RCC\) on page 112](#)).

### 6.1 Reset

There are three types of reset, defined as system reset, power reset and backup domain reset.

#### 6.1.1 System reset

A system reset sets all registers to their reset values except the reset flags in the clock controller CSR register and the registers in the Backup domain (see [Figure 4](#)).

A system reset is generated when one of the following events occurs:

1. A low level on the NRST pin (external reset)
2. Window watchdog end of count condition (WWDG reset)
3. Independent watchdog end of count condition (IWDG reset)
4. A software reset (SW reset) (see [Software reset](#))
5. Low-power management reset (see [Low-power management reset](#))

The reset source can be identified by checking the reset flags in the Control/Status register, RCC\_CSR (see [Section 6.3.10: Control/status register \(RCC\\_CSR\)](#)).

#### Software reset

The SYSRESETREQ bit in Cortex™-M3 Application Interrupt and Reset Control Register must be set to force a software reset on the device. Refer to the *STM32F10xxx Cortex-M3 programming manual* (see [Related documents on page 1](#)) for more details.

#### Low-power management reset

There are two ways to generate a low-power management reset:

1. Reset generated when entering Standby mode:  
This type of reset is enabled by resetting nRST\_STDBY bit in User Option Bytes. In this case, whenever a Standby mode entry sequence is successfully executed, the device is reset instead of entering Standby mode.
2. Reset when entering Stop mode:  
This type of reset is enabled by resetting nRST\_STOP bit in User Option Bytes. In this case, whenever a Stop mode entry sequence is successfully executed, the device is reset instead of entering Stop mode.

For further information on the User Option Bytes, refer to the STM32F10xxx Flash programming manual.

### 6.1.2 Power reset

A power reset is generated when one of the following events occurs:

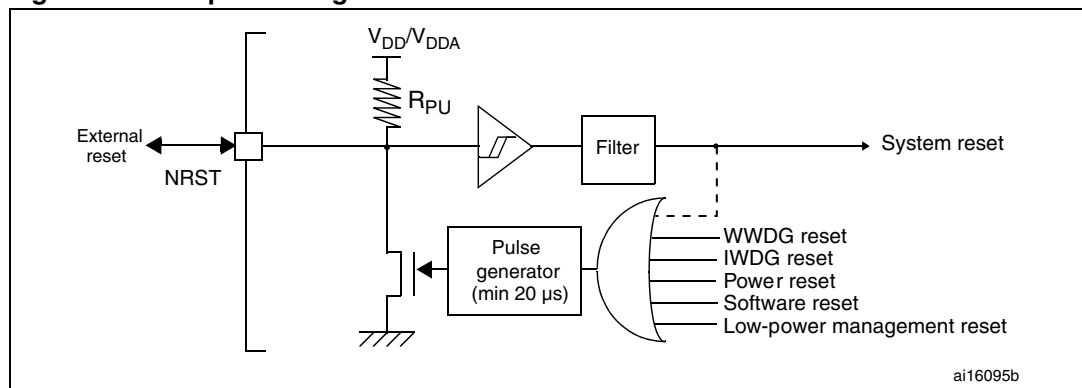
1. Power-on/power-down reset (POR/PDR reset)
2. When exiting Standby mode

A power reset sets all registers to their reset values except the Backup domain (see [Figure 4](#))

These sources act on the NRST pin and it is always kept low during the delay phase. The RESET service routine vector is fixed at address 0x0000\_0004 in the memory map.

The system reset signal provided to the device is output on the NRST pin. The pulse generator guarantees a minimum reset pulse duration of 20 μs for each reset source (external or internal reset). In case of an external reset, the reset pulse is generated while the NRST pin is asserted low.

**Figure 7. Simplified diagram of the reset circuit**



### 6.1.3 Backup domain reset

The backup domain has two specific resets that affect only the backup domain (see [Figure 4](#)).

A backup domain reset is generated when one of the following events occurs:

1. Software reset, triggered by setting the BDRST bit in the [Backup domain control register \(RCC\\_BDCR\)](#).
2. V<sub>DD</sub> or V<sub>BAT</sub> power on, if both supplies have previously been powered off.

## 6.2 Clocks

Three different clock sources can be used to drive the system clock (SYSCLK):

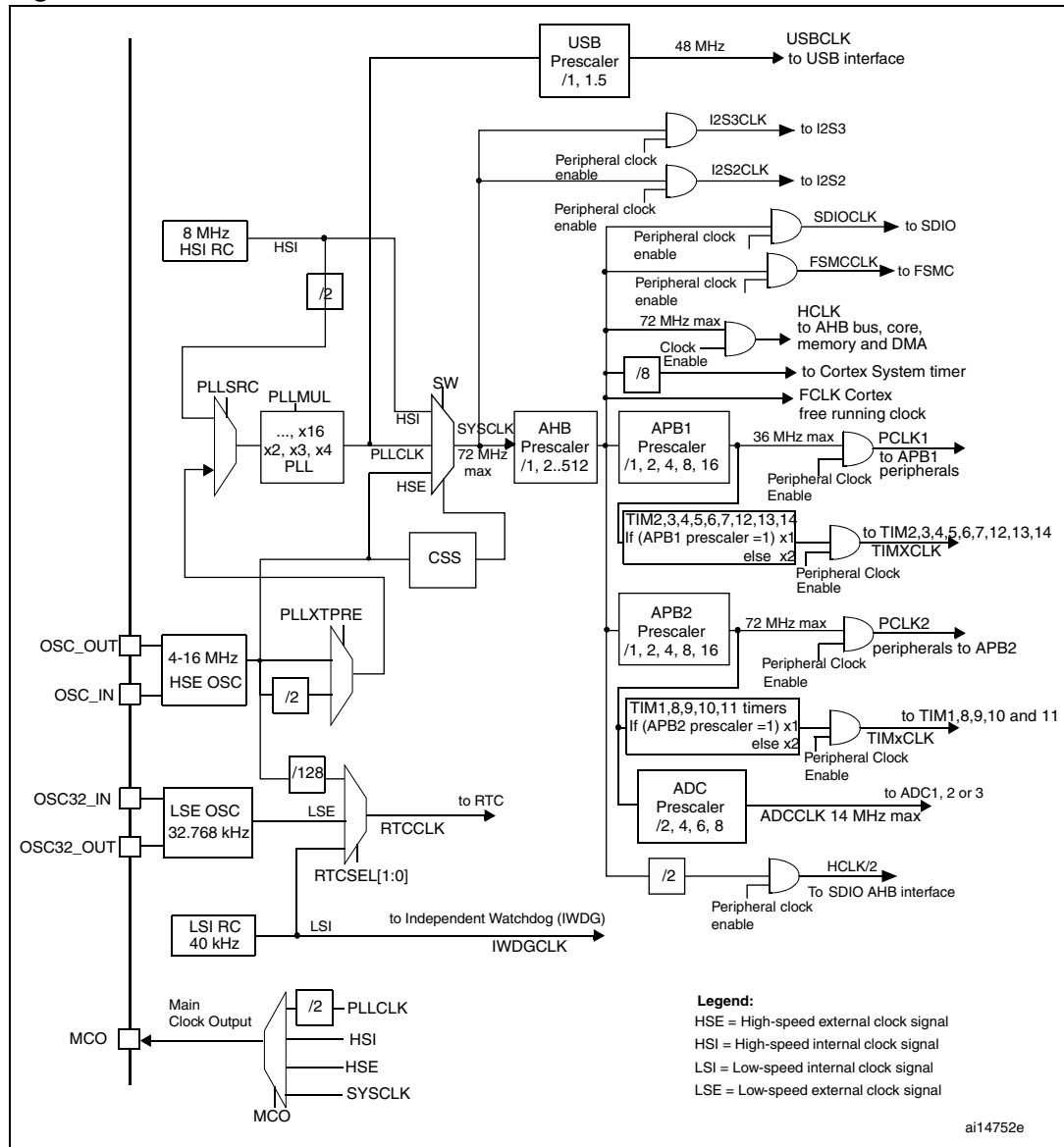
- HSI oscillator clock
- HSE oscillator clock
- PLL clock

The devices have the following two secondary clock sources:

- 40 kHz low speed internal RC (LSI RC) which drives the independent watchdog and optionally the RTC used for Auto-wakeup from Stop/Standby mode.
- 32.768 kHz low speed external crystal (LSE crystal) which optionally drives the real-time clock (RTCCLK)

Each clock source can be switched on or off independently when it is not used, to optimize power consumption.

Figure 8. Clock tree



1. When the HSI is used as a PLL clock input, the maximum system clock frequency that can be achieved is 64 MHz.
2. For full details about the internal and external clock source characteristics, please refer to the “Electrical characteristics” section in your device datasheet.

Several prescalers allow the configuration of the AHB frequency, the high speed APB (APB2) and the low speed APB (APB1) domains. The maximum frequency of the AHB and the APB2 domains is 72 MHz. The maximum allowed frequency of the APB1 domain is 36 MHz. The SDIO AHB interface is clocked with a fixed frequency equal to HCLK/2

The RCC feeds the Cortex System Timer (SysTick) external clock with the AHB clock (HCLK) divided by 8. The SysTick can work either with this clock or with the Cortex clock (HCLK), configurable in the SysTick Control and Status Register. The ADCs are clocked by the clock of the High Speed domain (APB2) divided by 2, 4, 6 or 8.

The timer clock frequencies are automatically fixed by hardware. There are two cases:

1. if the APB prescaler is 1, the timer clock frequencies are set to the same frequency as that of the APB domain to which the timers are connected.
2. otherwise, they are set to twice (x2) the frequency of the APB domain to which the timers are connected.

FCLK acts as Cortex™-M3's free-running clock. For more details refer to the ARM [Cortex™-M3 r1p1 Technical Reference Manual \(TRM\)](#).

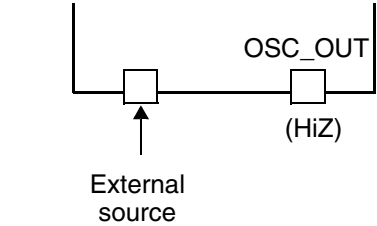
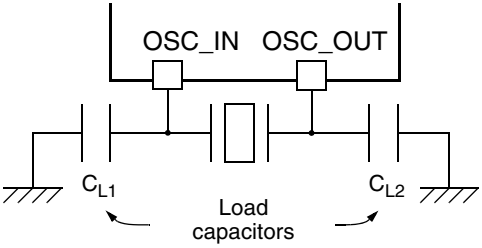
### 6.2.1 HSE clock

The high speed external clock signal (HSE) can be generated from two possible clock sources:

- HSE external crystal/ceramic resonator
- HSE user external clock

The resonator and the load capacitors have to be placed as close as possible to the oscillator pins in order to minimize output distortion and startup stabilization time. The loading capacitance values must be adjusted according to the selected oscillator.

**Figure 9. HSE/ LSE clock sources**

Clock source	Hardware configuration
<p><b>External clock</b></p>	
<p><b>Crystal/Ceramic resonators</b></p>	

#### External source (HSE bypass)

In this mode, an external clock source must be provided. It can have a frequency of up to 25 MHz. You select this mode by setting the HSEBYP and HSEON bits in the [Clock control register \(RCC\\_CR\)](#). The external clock signal (square, sinus or triangle) with ~50% duty cycle has to drive the OSC\_IN pin while the OSC\_OUT pin should be left hi-Z. See [Figure 9](#).

### External crystal/ceramic resonator (HSE crystal)

The 4 to 16 MHz external oscillator has the advantage of producing a very accurate rate on the main clock.

The associated hardware configuration is shown in [Figure 9](#). Refer to the electrical characteristics section of the *datasheet* for more details.

The HSERDY flag in the [Clock control register \(RCC\\_CR\)](#) indicates if the high-speed external oscillator is stable or not. At startup, the clock is not released until this bit is set by hardware. An interrupt can be generated if enabled in the [Clock interrupt register \(RCC\\_CIR\)](#).

The HSE Crystal can be switched on and off using the HSEON bit in the [Clock control register \(RCC\\_CR\)](#).

### 6.2.2 HSI clock

The HSI clock signal is generated from an internal 8 MHz RC Oscillator and can be used directly as a system clock or divided by 2 to be used as PLL input.

The HSI RC oscillator has the advantage of providing a clock source at low cost (no external components). It also has a faster startup time than the HSE crystal oscillator however, even with calibration the frequency is less accurate than an external crystal oscillator or ceramic resonator.

#### Calibration

RC oscillator frequencies can vary from one chip to another due to manufacturing process variations, this is why each device is factory calibrated by ST for 1% accuracy at  $T_A=25^{\circ}\text{C}$ .

After reset, the factory calibration value is loaded in the HSICAL[7:0] bits in the [Clock control register \(RCC\\_CR\)](#).

If the application is subject to voltage or temperature variations this may affect the RC oscillator speed. You can trim the HSI frequency in the application using the HSITRIM[4:0] bits in the [Clock control register \(RCC\\_CR\)](#).

The HSIRDY flag in the [Clock control register \(RCC\\_CR\)](#) indicates if the HSI RC is stable or not. At startup, the HSI RC output clock is not released until this bit is set by hardware.

The HSI RC can be switched on and off using the HSION bit in the [Clock control register \(RCC\\_CR\)](#).

The HSI signal can also be used as a backup source (Auxiliary clock) if the HSE crystal oscillator fails. Refer to [Section 6.2.7: Clock security system \(CSS\) on page 88](#).

### 6.2.3 PLL

The internal PLL can be used to multiply the HSI RC output or HSE crystal output clock frequency. Refer to [Figure 8](#) and [Clock control register \(RCC\\_CR\)](#).

The PLL configuration (selection of HSI oscillator divided by 2 or HSE oscillator for PLL input clock, and multiplication factor) must be done before enabling the PLL. Once the PLL enabled, these parameters cannot be changed.

An interrupt can be generated when the PLL is ready if enabled in the [Clock interrupt register \(RCC\\_CIR\)](#).

If the USB interface is used in the application, the PLL must be programmed to output 48 or 72 MHz. This is needed to provide a 48 MHz USBCLK.

#### 6.2.4 LSE clock

The LSE crystal is a 32.768 kHz Low Speed External crystal or ceramic resonator. It has the advantage providing a low-power but highly accurate clock source to the real-time clock peripheral (RTC) for clock/calendar or other timing functions.

The LSE crystal is switched on and off using the LSEON bit in [Backup domain control register \(RCC\\_BDCR\)](#).

The LSERDY flag in the [Backup domain control register \(RCC\\_BDCR\)](#) indicates if the LSE crystal is stable or not. At startup, the LSE crystal output clock signal is not released until this bit is set by hardware. An interrupt can be generated if enabled in the [Clock interrupt register \(RCC\\_CIR\)](#).

##### External source (LSE bypass)

In this mode, an external clock source must be provided. It can have a frequency of up to 1 MHz. You select this mode by setting the LSEBYP and LSEON bits in the [Backup domain control register \(RCC\\_BDCR\)](#). The external clock signal (square, sinus or triangle) with ~50% duty cycle has to drive the OSC32\_IN pin while the OSC32\_OUT pin should be left Hi-Z. See [Figure 9](#).

#### 6.2.5 LSI clock

The LSI RC acts as an low-power clock source that can be kept running in Stop and Standby mode for the independent watchdog (IWDG) and Auto-wakeup unit (AWU). The clock frequency is around 40 kHz (between 30 kHz and 60 kHz). For more details, refer to the electrical characteristics section of the datasheets.

The LSI RC can be switched on and off using the LSION bit in the [Control/status register \(RCC\\_CSR\)](#).

The LSIRDY flag in the [Control/status register \(RCC\\_CSR\)](#) indicates if the low-speed internal oscillator is stable or not. At startup, the clock is not released until this bit is set by hardware. An interrupt can be generated if enabled in the [Clock interrupt register \(RCC\\_CIR\)](#).

*Note:* LSI calibration is only available on high-density, XL-density and connectivity line devices.

##### LSI calibration

The frequency dispersion of the Low Speed Internal RC (LSI) oscillator can be calibrated to have accurate RTC time base and/or IWDG timeout (when LSI is used as clock source for these peripherals) with an acceptable accuracy.

This calibration is performed by measuring the LSI clock frequency with respect to TIM5 input clock (TIM5CLK). According to this measurement done at the precision of the HSE oscillator, the software can adjust the programmable 20-bit prescaler of the RTC to get an accurate time base or can compute accurate IWDG timeout.

Use the following procedure to calibrate the LSI:

1. Enable TIM5 timer and configure channel4 in input capture mode
2. Set the TIM5CH4\_IREMAP bit in the AFIO\_MAPR register to connect the LSI clock internally to TIM5 channel4 input capture for calibration purpose.
3. Measure the frequency of LSI clock using the TIM5 Capture/compare 4 event or interrupt.
4. Use the measured LSI frequency to update the 20-bit prescaler of the RTC depending on the desired time base and/or to compute the IWDG timeout.

## 6.2.6 System clock (SYSCLK) selection

After a system reset, the HSI oscillator is selected as system clock. When a clock source is used directly or through the PLL as system clock, it is not possible to stop it.

A switch from one clock source to another occurs only if the target clock source is ready (clock stable after startup delay or PLL locked). If a clock source which is not yet ready is selected, the switch will occur when the clock source will be ready. Status bits in the [Clock control register \(RCC\\_CR\)](#) indicate which clock(s) is (are) ready and which clock is currently used as system clock.

## 6.2.7 Clock security system (CSS)

Clock Security System can be activated by software. In this case, the clock detector is enabled after the HSE oscillator startup delay, and disabled when this oscillator is stopped.

If a failure is detected on the HSE oscillator clock, this oscillator is automatically disabled, a clock failure event is sent to the break input of the advanced-control timers (TIM1 and TIM8) and an interrupt is generated to inform the software about the failure (Clock Security System Interrupt CSSI), allowing the MCU to perform rescue operations. The CSSI is linked to the Cortex™-M3 NMI (Non-Maskable Interrupt) exception vector.

*Note:* Once the CSS is enabled and if the HSE clock fails, the CSS interrupt occurs and an NMI is automatically generated. The NMI will be executed indefinitely unless the CSS interrupt pending bit is cleared. As a consequence, in the NMI ISR user must clear the CSS interrupt by setting the CSSC bit in the [Clock interrupt register \(RCC\\_CIR\)](#).

If the HSE oscillator is used directly or indirectly as the system clock (indirectly means: it is used as PLL input clock, and the PLL clock is used as system clock), a detected failure causes a switch of the system clock to the HSI oscillator and the disabling of the external HSE oscillator. If the HSE oscillator clock (divided or not) is the clock entry of the PLL used as system clock when the failure occurs, the PLL is disabled too.

## 6.2.8 RTC clock

The RTCCLK clock source can be either the HSE/128, LSE or LSI clocks. This is selected by programming the RTCSEL[1:0] bits in the [Backup domain control register \(RCC\\_BDCR\)](#). This selection cannot be modified without resetting the Backup domain.



The LSE clock is in the Backup domain, whereas the HSE and LSI clocks are not. Consequently:

- If LSE is selected as RTC clock:
  - The RTC continues to work even if the  $V_{DD}$  supply is switched off, provided the  $V_{BAT}$  supply is maintained.
- If LSI is selected as Auto-Wakeup unit (AWU) clock:
  - The AWU state is not guaranteed if the  $V_{DD}$  supply is powered off. Refer to [Section 6.2.5: LSI clock on page 87](#) for more details on LSI calibration.
- If the HSE clock divided by 128 is used as the RTC clock:
  - The RTC state is not guaranteed if the  $V_{DD}$  supply is powered off or if the internal voltage regulator is powered off (removing power from the 1.8 V domain).
  - The DPB bit (Disable backup domain write protection) in the Power controller register must be set to 1 (refer to [Section 4.4.1: Power control register \(PWR\\_CR\)](#)).

### 6.2.9 Watchdog clock

If the Independent watchdog (IWDG) is started by either hardware option or software access, the LSI oscillator is forced ON and cannot be disabled. After the LSI oscillator temporization, the clock is provided to the IWDG.

### 6.2.10 Clock-out capability

The microcontroller clock output (MCO) capability allows the clock to be output onto the external MCO pin. The configuration registers of the corresponding GPIO port must be programmed in alternate function mode. One of 4 clock signals can be selected as the MCO clock.

- SYSCLK
- HSI
- HSE
- PLL clock divided by 2

The selection is controlled by the MCO[2:0] bits of the [Clock configuration register \(RCC\\_CFGR\)](#).

## 6.3 RCC registers

Refer to [Section 1.1 on page 40](#) for a list of abbreviations used in register descriptions.

### 6.3.1 Clock control register (RCC\_CR)

Address offset: 0x00

Reset value: 0x0000 XX83 where X is undefined.

Access: no wait state, word, half-word and byte access

31	30	29	28	27	26	25	24	23	22	21	20	19	18	17	16
Reserved						PLL RDY	PLLON	Reserved				CSS ON	HSE BYP	HSE RDY	HSE ON
						r	rw					rw	rw	r	rw
15	14	13	12	11	10	9	8	7	6	5	4	3	2	1	0
HSICAL[7:0]								HSITRIM[4:0]					Res.	HSI RDY	HSION
r	r	r	r	r	r	r	r	rw	rw	rw	rw	rw		r	rw

Bits 31:26 Reserved, always read as 0.

Bit 25 **PLL RDY**: PLL clock ready flag

Set by hardware to indicate that the PLL is locked.

0: PLL unlocked

1: PLL locked

Bit 24 **PLLON**: PLL enable

Set and cleared by software to enable PLL.

Cleared by hardware when entering Stop or Standby mode. This bit can not be reset if the PLL clock is used as system clock or is selected to become the system clock.

0: PLL OFF

1: PLL ON

Bits 23:20 Reserved, always read as 0.

Bit 19 **CSSON**: Clock security system enable

Set and cleared by software to enable clock detector.

0: Clock detector OFF

1: Clock detector ON if external 4-16 MHz oscillator is ready.

Bit 18 **HSEBYP**: External high-speed clock bypass

Set and cleared by software for bypassing the oscillator with an external clock. This bit can be written only if the external 4-16 MHz oscillator is disabled.

0: external 4-16 MHz oscillator not bypassed

1: external 4-16 MHz oscillator bypassed with external clock

Bit 17 **HSERDY**: External high-speed clock ready flag

Set by hardware to indicate that the external 4-16 MHz oscillator is stable. This bit needs 6 cycles of external 4-16 MHz oscillator clock to fall down after HSEON reset.

0: external 4-16 MHz oscillator not ready

1: external 4-16 MHz oscillator ready

Bit 16 **HSEON**: External high-speed clock enable

Set and cleared by software.

Cleared by hardware to stop the external 1-25MHz oscillator when entering in Stop or Standby mode. This bit cannot be reset if the external 4-16 MHz oscillator is used directly or indirectly as the system clock or is selected to become the system clock.

0: HSE oscillator OFF

1: HSE oscillator ON

Bits 15:8 **HSICAL[7:0]**: Internal high-speed clock calibration

These bits are initialized automatically at startup.

Bits 7:3 **HSITRIM[4:0]**: Internal high-speed clock trimming

These bits provide an additional user-programmable trimming value that is added to the HSICAL[7:0] bits. It can be programmed to adjust to variations in voltage and temperature that influence the frequency of the internal HSI RC.

The default value is 16, which, when added to the HSICAL value, should trim the HSI to 8 MHz  $\pm$  1%. The trimming step ( $F_{\text{hsitrim}}$ ) is around 40 kHz between two consecutive HSICAL steps.

Bit 2 Reserved, always read as 0.

Bit 1 **HSIRDY**: Internal high-speed clock ready flag

Set by hardware to indicate that internal 8 MHz RC oscillator is stable. After the HSION bit is cleared, HSIRDY goes low after 6 internal 8 MHz RC oscillator clock cycles.

0: internal 8 MHz RC oscillator not ready

1: internal 8 MHz RC oscillator ready

Bit 0 **HSION**: Internal high-speed clock enable

Set and cleared by software.

Set by hardware to force the internal 8 MHz RC oscillator ON when leaving Stop or Standby mode or in case of failure of the external 4-16 MHz oscillator used directly or indirectly as system clock. This bit cannot be reset if the internal 8 MHz RC is used directly or indirectly as system clock or is selected to become the system clock.

0: internal 8 MHz RC oscillator OFF

1: internal 8 MHz RC oscillator ON

### 6.3.2 Clock configuration register (RCC\_CFGR)

Address offset: 0x04

Reset value: 0x0000 0000

Access: 0 ≤ wait state ≤ 2, word, half-word and byte access

1 or 2 wait states inserted only if the access occurs during clock source switch.

31	30	29	28	27	26	25	24	23	22	21	20	19	18	17	16
Reserved					MCO[2:0]			Res.	USB PRE	PLLMUL[3:0]				PLL XTPRE	PLL SRC
					rw	rw	rw		rw	rw	rw	rw	rw	rw	rw
15	14	13	12	11	10	9	8	7	6	5	4	3	2	1	0
ADC PRE[1:0]		PPRE2[2:0]			PPRE1[2:0]			HPRE[3:0]				SWS[1:0]		SW[1:0]	
rw	rw	rw	rw	rw	rw	rw	rw	rw	rw	rw	rw	r	r	rw	rw

Bits 31:27 Reserved, always read as 0.

Bits 26:24 **MCO**: Microcontroller clock output

Set and cleared by software.

0xx: No clock

100: System clock (SYSCLK) selected

101: HSI clock selected

110: HSE clock selected

111: PLL clock divided by 2 selected

*Note: This clock output may have some truncated cycles at startup or during MCO clock source switching.*

*When the System Clock is selected to output to the MCO pin, make sure that this clock does not exceed 50 MHz (the maximum IO speed).*

Bit 22 **USBPRE**: USB prescaler

Set and cleared by software to generate 48 MHz USB clock. This bit must be valid before enabling the USB clock in the RCC\_APB1ENR register. This bit can't be reset if the USB clock is enabled.

0: PLL clock is divided by 1.5

1: PLL clock is not divided

**Bits 21:18 PLLMUL:** PLL multiplication factor

These bits are written by software to define the PLL multiplication factor. These bits can be written only when PLL is disabled.

Caution: The PLL output frequency must not exceed 72 MHz.

0000: PLL input clock x 2

0001: PLL input clock x 3

0010: PLL input clock x 4

0011: PLL input clock x 5

0100: PLL input clock x 6

0101: PLL input clock x 7

0110: PLL input clock x 8

0111: PLL input clock x 9

1000: PLL input clock x 10

1001: PLL input clock x 11

1010: PLL input clock x 12

1011: PLL input clock x 13

1100: PLL input clock x 14

1101: PLL input clock x 15

1110: PLL input clock x 16

1111: PLL input clock x 16

**Bit 17 PLLXTPRE:** HSE divider for PLL entry

Set and cleared by software to divide HSE before PLL entry. This bit can be written only when PLL is disabled.

0: HSE clock not divided

1: HSE clock divided by 2

**Bit 16 PLLSRC:** PLL entry clock source

Set and cleared by software to select PLL clock source. This bit can be written only when PLL is disabled.

0: HSI oscillator clock / 2 selected as PLL input clock

1: HSE oscillator clock selected as PLL input clock

**Bits 15:14 ADCPRE:** ADC prescaler

Set and cleared by software to select the frequency of the clock to the ADCs.

00: PCLK2 divided by 2

01: PCLK2 divided by 4

10: PCLK2 divided by 6

11: PCLK2 divided by 8

**Bits 13:11 PPRE2:** APB high-speed prescaler (APB2)

Set and cleared by software to control the division factor of the APB high-speed clock (PCLK2).

0xx: HCLK not divided

100: HCLK divided by 2

101: HCLK divided by 4

110: HCLK divided by 8

111: HCLK divided by 16

Bits 10:8 **PPRE1**: APB low-speed prescaler (APB1)

Set and cleared by software to control the division factor of the APB low-speed clock (PCLK1).

Warning: the software has to set correctly these bits to not exceed 36 MHz on this domain.

0xx: HCLK not divided

100: HCLK divided by 2

101: HCLK divided by 4

110: HCLK divided by 8

111: HCLK divided by 16

Bits 7:4 **HPRE**: AHB prescaler

Set and cleared by software to control the division factor of the AHB clock.

0xxx: SYSCLK not divided

1000: SYSCLK divided by 2

1001: SYSCLK divided by 4

1010: SYSCLK divided by 8

1011: SYSCLK divided by 16

1100: SYSCLK divided by 64

1101: SYSCLK divided by 128

1110: SYSCLK divided by 256

1111: SYSCLK divided by 512

*Note: The prefetch buffer must be kept on when using a prescaler different from 1 on the AHB clock. Refer to [Reading the Flash memory on page 52](#) section for more details.*

Bits 3:2 **SWS**: System clock switch status

Set and cleared by hardware to indicate which clock source is used as system clock.

00: HSI oscillator used as system clock

01: HSE oscillator used as system clock

10: PLL used as system clock

11: not applicable

Bits 1:0 **SW**: System clock switch

Set and cleared by software to select SYSCLK source.

Set by hardware to force HSI selection when leaving Stop and Standby mode or in case of failure of the HSE oscillator used directly or indirectly as system clock (if the Clock Security System is enabled).

00: HSI selected as system clock

01: HSE selected as system clock

10: PLL selected as system clock

11: not allowed

### 6.3.3 Clock interrupt register (RCC\_CIR)

Address offset: 0x08

Reset value: 0x0000 0000

Access: no wait state, word, half-word and byte access

31	30	29	28	27	26	25	24	23	22	21	20	19	18	17	16	
Reserved								CSSC	Reserved			PLL RDYC	HSE RDYC	HSI RDYC	LSE RDYC	LSI RDYC
								w				w	w	w	w	w
15	14	13	12	11	10	9	8	7	6	5	4	3	2	1	0	
Reserved			PLL RDYIE	HSE RDYIE	HSI RDYIE	LSE RDYIE	LSI RDYIE	CSSF	Reserved			PLL RDYF	HSE RDYF	HSI RDYF	LSE RDYF	LSI RDYF
			rw	rw	rw	rw	rw	r				r	r	r	r	r

Bits 31:24 Reserved, always read as 0.

Bit 23 **CSSC**: Clock security system interrupt clear

This bit is set by software to clear the CSSF flag.

0: No effect

1: Clear CSSF flag

Bits 22:21 Reserved, always read as 0.

Bit 20 **PLL RDYC**: PLL ready interrupt clear

This bit is set by software to clear the PLLRDYF flag.

0: No effect

1: PLLRDYF cleared

Bit 19 **HSERDYC**: HSE ready interrupt clear

This bit is set by software to clear the HSERDYF flag.

0: No effect

1: HSERDYF cleared

Bit 18 **HSIRDYC**: HSI ready interrupt clear

This bit is set software to clear the HSIRDYF flag.

0: No effect

1: HSIRDYF cleared

Bit 17 **LSERDYC**: LSE ready interrupt clear

This bit is set by software to clear the LSERDYF flag.

0: No effect

1: LSERDYF cleared

Bit 16 **LSIRDYC**: LSI ready interrupt clear

This bit is set by software to clear the LSIRDYF flag.

0: No effect

1: LSIRDYF cleared

Bits 15:13 Reserved, always read as 0.

- Bit 12 **PLLRDYIE**: PLL ready interrupt enable  
Set and cleared by software to enable/disable interrupt caused by PLL lock.  
0: PLL lock interrupt disabled  
1: PLL lock interrupt enabled
- Bit 11 **HSERDYIE**: HSE ready interrupt enable  
Set and cleared by software to enable/disable interrupt caused by the external 4-16 MHz oscillator stabilization.  
0: HSE ready interrupt disabled  
1: HSE ready interrupt enabled
- Bit 10 **HSIRDYIE**: HSI ready interrupt enable  
Set and cleared by software to enable/disable interrupt caused by the internal 8 MHz RC oscillator stabilization.  
0: HSI ready interrupt disabled  
1: HSI ready interrupt enabled
- Bit 9 **LSERDYIE**: LSE ready interrupt enable  
Set and cleared by software to enable/disable interrupt caused by the external 32 kHz oscillator stabilization.  
0: LSE ready interrupt disabled  
1: LSE ready interrupt enabled
- Bit 8 **LSIRDYIE**: LSI ready interrupt enable  
Set and cleared by software to enable/disable interrupt caused by internal RC 40 kHz oscillator stabilization.  
0: LSI ready interrupt disabled  
1: LSI ready interrupt enabled
- Bit 7 **CSSF**: Clock security system interrupt flag  
Set by hardware when a failure is detected in the external 4-16 MHz oscillator.  
Cleared by software setting the CSSC bit.  
0: No clock security interrupt caused by HSE clock failure  
1: Clock security interrupt caused by HSE clock failure
- Bits 6:5 Reserved, always read as 0.
- Bit 4 **PLLRDYF**: PLL ready interrupt flag  
Set by hardware when the PLL locks and PLLRDYDIE is set.  
Cleared by software setting the PLLRDYC bit.  
0: No clock ready interrupt caused by PLL lock  
1: Clock ready interrupt caused by PLL lock
- Bit3 **HSERDYF**: HSE ready interrupt flag  
Set by hardware when External Low Speed clock becomes stable and HSERDYDIE is set.  
Cleared by software setting the HSERDYC bit.  
0: No clock ready interrupt caused by the external 4-16 MHz oscillator  
1: Clock ready interrupt caused by the external 4-16 MHz oscillator
- Bit 2 **HSIRDYF**: HSI ready interrupt flag  
Set by hardware when the Internal High Speed clock becomes stable and HSIRDYDIE is set.  
Cleared by software setting the HSIRDYC bit.  
0: No clock ready interrupt caused by the internal 8 MHz RC oscillator  
1: Clock ready interrupt caused by the internal 8 MHz RC oscillator



- Bit 1 **LSERDYF**: LSE ready interrupt flag  
 Set by hardware when the External Low Speed clock becomes stable and LSERDYDIE is set.  
 Cleared by software setting the LSERDYC bit.  
 0: No clock ready interrupt caused by the external 32 kHz oscillator  
 1: Clock ready interrupt caused by the external 32 kHz oscillator
- Bit 0 **LSIRDYF**: LSI ready interrupt flag  
 Set by hardware when the internal low speed clock becomes stable and LSIRDYDIE is set.  
 Cleared by software setting the LSIRDYC bit.  
 0: No clock ready interrupt caused by the internal RC 40 kHz oscillator  
 1: Clock ready interrupt caused by the internal RC 40 kHz oscillator

### 6.3.4 APB2 peripheral reset register (RCC\_APB2RSTR)

Address offset: 0x0C

Reset value: 0x00000 0000

Access: no wait state, word, half-word and byte access

31	30	29	28	27	26	25	24	23	22	21	20	19	18	17	16
Reserved										TIM11 RST	TIM10 RST	TIM9 RST	Reserved		
										rw	rw	rw			
15	14	13	12	11	10	9	8	7	6	5	4	3	2	1	0
ADC3 RST	USART1 RST	TIM8 RST	SPI1 RST	TIM1 RST	ADC2 RST	ADC1 RST	IOPG RST	IOPF RST	IOPE RST	IOPD RST	IOPC RST	IOPB RST	IOPA RST	Res.	AFIO RST
rw	rw	rw	rw	rw	rw	rw	rw	rw	rw	rw	rw	rw	rw	Res.	rw

Bits 31:22 Reserved, always read as 0.

- Bit 21 **TIM11RST**: TIM11 timer reset  
 Set and cleared by software.  
 0: No effect  
 1: Reset TIM11 timer

- Bit 20 **TIM10RST**: TIM10 timer reset  
 Set and cleared by software.  
 0: No effect  
 1: Reset TIM10 timer

- Bit 19 **TIM9RST**: TIM9 timer reset  
 Set and cleared by software.  
 0: No effect  
 1: Reset TIM9 timer

Bits 18:16 Reserved, always read as 0.

- Bit 15 **ADC3RST**: ADC3 interface reset  
 Set and cleared by software.  
 0: No effect  
 1: Reset ADC3 interface

- Bit 14 **USART1RST**: USART1 reset  
Set and cleared by software.  
0: No effect  
1: Reset USART1
- ADC1RST**: ADC1 interface reset  
Set and cleared by software.  
0: No effect  
1: Reset ADC1 interface
- Bit 13 **TIM8RST**: TIM8 timer reset  
Set and cleared by software.  
0: No effect  
1: Reset TIM8 timer
- Bit 12 **SPI1RST**: SPI1 reset  
Set and cleared by software.  
0: No effect  
1: Reset SPI1
- Bit 11 **TIM1RST**: TIM1 timer reset  
Set and cleared by software.  
0: No effect  
1: Reset TIM1 timer
- Bit 10 **ADC2RST**: ADC 2 interface reset  
Set and cleared by software.  
0: No effect  
1: Reset ADC 2 interface
- Bit 9 **ADC1RST**: ADC 1 interface reset  
Set and cleared by software.  
0: No effect  
1: Reset ADC 1 interface
- Bit 8 **IOPGRST**: IO port G reset  
Set and cleared by software.  
0: No effect  
1: Reset IO port G
- Bit 7 **IOPFRST**: IO port F reset  
Set and cleared by software.  
0: No effect  
1: Reset IO port F
- Bit 6 **IOPERST**: IO port E reset  
Set and cleared by software.  
0: No effect  
1: Reset IO port E
- Bit 5 **IOPDRST**: IO port D reset  
Set and cleared by software.  
0: No effect  
1: Reset IO port D

- Bit 4 **IOPCRST**: IO port C reset  
Set and cleared by software.  
0: No effect  
1: Reset IO port C
- Bit 3 **IOPBRST**: IO port B reset  
Set and cleared by software.  
0: No effect  
1: Reset IO port B
- Bit 2 **IOPARST**: IO port A reset  
Set and cleared by software.  
0: No effect  
1: Reset IO port A
- Bit 1 Reserved, always read as 0.
- Bit 0 **AFIORST**: Alternate function IO reset  
Set and cleared by software.  
0: No effect  
1: Reset Alternate Function

### 6.3.5 APB1 peripheral reset register (RCC\_APB1RSTR)

Address offset: 0x10

Reset value: 0x0000 0000

Access: no wait state, word, half-word and byte access

31		30		29		28		27		26		25		24		23		22		21		20		19		18		17		16	
Reserved				DAC RST	PWR RST	BKP RST	Res.	CAN RST	Res.	USB RST	I2C2 RST	I2C1 RST	UART 5 RST	UART 4 RST	USART 3 RST	USART 2 RST	Res.														
				rw	rw	rw		rw		rw	rw	rw	rw	rw	rw	rw															
15		14		13		12		11		10		9		8		7		6		5		4		3		2		1		0	
SPI3 RST	SPI2 RST	Reserved				WWD GRST	Reserved				TIM14 RST	TIM13 RST	TIM12 RST	TIM7 RST	TIM6 RST	TIM5 RST	TIM4 RST	TIM3 RST	TIM2 RST												
rw	rw					rw					rw	rw	rw	rw	rw	rw	rw	rw	rw	rw											

Bits 31:30 Reserved, always read as 0.

- Bit 29 **DACRST**: DAC interface reset  
Set and cleared by software.  
0: No effect  
1: Reset DAC interface
- Bit 28 **PWRRST**: Power interface reset  
Set and cleared by software.  
0: No effect  
1: Reset power interface

- Bit 27 **BKPRST**: Backup interface reset  
Set and cleared by software.  
0: No effect  
1: Reset backup interface
- Bit 26 Reserved, always read as 0.
- Bit 25 **CANRST**: CAN reset  
Set and cleared by software.  
0: No effect  
1: Reset CAN
- Bit 24 Reserved, always read as 0.
- Bit 23 **USBRST**: USB reset  
Set and cleared by software.  
0: No effect  
1: Reset USB
- Bit 22 **I2C2RST**: I2C 2 reset  
Set and cleared by software.  
0: No effect  
1: Reset I2C 2
- Bit 21 **I2C1RST**: I2C 1 reset  
Set and cleared by software.  
0: No effect  
1: Reset I2C 1
- Bit 20 **UART5RST**: USART 5 reset  
Set and cleared by software.  
0: No effect  
1: Reset USART 5
- Bit 19 **UART4RST**: USART 4 reset  
Set and cleared by software.  
0: No effect  
1: Reset USART 4
- Bit 18 **USART3RST**: USART 3 reset  
Set and cleared by software.  
0: No effect  
1: Reset USART 3
- Bit 17 **USART2RST**: USART 2 reset  
Set and cleared by software.  
0: No effect  
1: Reset USART 2
- Bit 16 Reserved, always read as 0.
- Bit 15 **SPI3RST**: SPI 3 reset  
Set and cleared by software.  
0: No effect  
1: Reset SPI 3

Bit 14 **SPI2RST**: SPI 2 reset  
Set and cleared by software.  
0: No effect  
1: Reset SPI 2

Bits 13:12 Reserved, always read as 0.

Bit 11 **WWDGRST**: Window watchdog reset  
Set and cleared by software.  
0: No effect  
1: Reset window watchdog

Bits 10:9 Reserved, always read as 0.

Bit 8 **TIM14RST**: TIM14 timer reset  
Set and cleared by software.  
0: No effect  
1: Reset TIM14

Bit 7 **TIM13RST**: TIM13 timer reset  
Set and cleared by software.  
0: No effect  
1: Reset TIM13

Bit 6 **TIM12RST**: TIM12 timer reset  
Set and cleared by software.  
0: No effect  
1: Reset TIM12

Bit 5 **TIM7RST**: TIM7 timer reset  
Set and cleared by software.  
0: No effect  
1: Reset TIM7

Bit 4 **TIM6RST**: TIM6 timer reset  
Set and cleared by software.  
0: No effect  
1: Reset TIM6

Bit 3 **TIM5RST**: TIM5 timer reset  
Set and cleared by software.  
0: No effect  
1: Reset TIM5

Bit 2 **TIM4RST**: TIM4 timer reset  
Set and cleared by software.  
0: No effect  
1: Reset TIM4

Bit 1 **TIM3RST**: TIM3 timer reset  
Set and cleared by software.  
0: No effect  
1: Reset TIM3

Bit 0 **TIM2RST**: TIM2 timer reset  
Set and cleared by software.  
0: No effect  
1: Reset TIM2

### 6.3.6 AHB peripheral clock enable register (RCC\_AHBENR)

Address offset: 0x14

Reset value: 0x0000 0014

Access: no wait state, word, half-word and byte access

*Note: When the peripheral clock is not active, the peripheral register values may not be readable by software and the returned value is always 0x0.*

31	30	29	28	27	26	25	24	23	22	21	20	19	18	17	16
Reserved															
15	14	13	12	11	10	9	8	7	6	5	4	3	2	1	0
Reserved				SDIO EN	Res.	FSMC EN	Res.	CRCE N	Res.	FLITF EN	Res.	SRAM EN	DMA2 EN	DMA1 EN	
				rw		rw		rw		rw		rw	rw	rw	

Bits 31:11 Reserved, always read as 0.

Bit 10 **SDIOEN**: SDIO clock enable  
 Set and cleared by software.  
 0: SDIO clock disabled  
 1: SDIO clock enabled

Bits 9 Reserved, always read as 0.

Bit 8 **FSMCEN**: FSMC clock enable  
 Set and cleared by software.  
 0: FSMC clock disabled  
 1: FSMC clock enabled

Bit 7 Reserved, always read as 0.

Bit 6 **CRCEEN**: CRC clock enable  
 Set and cleared by software.  
 0: CRC clock disabled  
 1: CRC clock enabled

Bit 5 Reserved, always read as 0.

Bit 4 **FLITFEN**: FLITF clock enable  
 Set and cleared by software to disable/enable FLITF clock during Sleep mode.  
 0: FLITF clock disabled during Sleep mode  
 1: FLITF clock enabled during Sleep mode

Bit 3 Reserved, always read as 0.

Bit 2 **SRAMEN**: SRAM interface clock enable  
 Set and cleared by software to disable/enable SRAM interface clock during Sleep mode.  
 0: SRAM interface clock disabled during Sleep mode.  
 1: SRAM interface clock enabled during Sleep mode

Bit 1 **DMA2EN**: DMA2 clock enable  
 Set and cleared by software.  
 0: DMA2 clock disabled  
 1: DMA2 clock enabled

Bit 0 **DMA1EN**: DMA1 clock enable  
 Set and cleared by software.  
 0: DMA1 clock disabled  
 1: DMA1 clock enabled

### 6.3.7 APB2 peripheral clock enable register (RCC\_APB2ENR)

Address: 0x18

Reset value: 0x0000 0000

Access: word, half-word and byte access

No wait states, except if the access occurs while an access to a peripheral in the APB2 domain is on going. In this case, wait states are inserted until the access to APB2 peripheral is finished.

*Note: When the peripheral clock is not active, the peripheral register values may not be readable by software and the returned value is always 0x0.*

31	30	29	28	27	26	25	24	23	22	21	20	19	18	17	16
Reserved										TIM11 EN	TIM10 EN	TIM9 EN	Reserved		
										rw	rw	rw			
15	14	13	12	11	10	9	8	7	6	5	4	3	2	1	0
ADC3 EN	USAR T1EN	TIM8 EN	SPI1 EN	TIM1 EN	ADC2 EN	ADC1 EN	IOPG EN	IOPF EN	IOPE EN	IOPD EN	IOPC EN	IOPB EN	IOPA EN	Res.	AFIO EN
rw	rw	rw	rw	rw	rw	rw	rw	rw	rw	rw	rw	rw	rw		rw

Bits 31:22 Reserved, always read as 0.

Bit 21 **TIM11EN**: TIM11 timer clock enable  
 Set and cleared by software.  
 0: TIM11 timer clock disabled  
 1: TIM11 timer clock enabled

Bit 20 **TIM10EN**: TIM10 timer clock enable  
 Set and cleared by software.  
 0: TIM10 timer clock disabled  
 1: TIM10 timer clock enabled

Bit 19 **TIM9EN**: TIM9 timer clock enable  
 Set and cleared by software.  
 0: TIM9 timer clock disabled  
 1: TIM9 timer clock enabled

Bits 18:16 Reserved, always read as 0.

Bit 15 **ADC3EN**: ADC 3 interface clock enable  
 Set and cleared by software.  
 0: ADC 3 interface clock disabled  
 1: ADC 3 interface clock enabled

- Bit 14 **USART1EN**: USART1 clock enable  
Set and cleared by software.  
0: USART1 clock disabled  
1: USART1 clock enabled
- Bit 13 **TIM8EN**: TIM8 Timer clock enable  
Set and cleared by software.  
0: TIM8 timer clock disabled  
1: TIM8 timer clock enabled
- Bit 12 **SPI1EN**: SPI 1 clock enable  
Set and cleared by software.  
0: SPI 1 clock disabled  
1: SPI 1 clock enabled
- Bit 11 **TIM1EN**: TIM1 timer clock enable  
Set and cleared by software.  
0: TIM1 timer clock disabled  
1: TIM1 timer clock enabled
- Bit 10 **ADC2EN**: ADC 2 interface clock enable  
Set and cleared by software.  
0: ADC 2 interface clock disabled  
1: ADC 2 interface clock enabled
- Bit 9 **ADC1EN**: ADC 1 interface clock enable  
Set and cleared by software.  
0: ADC 1 interface disabled  
1: ADC 1 interface clock enabled
- Bit 8 **IOPGEN**: IO port G clock enable  
Set and cleared by software.  
0: IO port G clock disabled  
1: IO port G clock enabled
- Bit 7 **IOPFEN**: IO port F clock enable  
Set and cleared by software.  
0: IO port F clock disabled  
1: IO port F clock enabled
- Bit 6 **IOPEEN**: IO port E clock enable  
Set and cleared by software.  
0: IO port E clock disabled  
1: IO port E clock enabled
- Bit 5 **IOPDEN**: IO port D clock enable  
Set and cleared by software.  
0: IO port D clock disabled  
1: IO port D clock enabled
- Bit 4 **IOPCEN**: IO port C clock enable  
Set and cleared by software.  
0: IO port C clock disabled  
1: IO port C clock enabled



- Bit 3 **IOPBEN**: IO port B clock enable  
Set and cleared by software.  
0: IO port B clock disabled  
1: IO port B clock enabled
- Bit 2 **IOPAEN**: IO port A clock enable  
Set and cleared by software.  
0: IO port A clock disabled  
1: IO port A clock enabled
- Bit 1 Reserved, always read as 0.
- Bit 0 **AFIOEN**: Alternate function IO clock enable  
Set and cleared by software.  
0: Alternate Function IO clock disabled  
1: Alternate Function IO clock enabled

### 6.3.8 APB1 peripheral clock enable register (RCC\_APB1ENR)

Address: 0x1C

Reset value: 0x0000 0000

Access: word, half-word and byte access

No wait state, except if the access occurs while an access to a peripheral on APB1 domain is on going. In this case, wait states are inserted until this access to APB1 peripheral is finished.

*Note: When the peripheral clock is not active, the peripheral register values may not be readable by software and the returned value is always 0x0.*

31	30	29	28	27	26	25	24	23	22	21	20	19	18	17	16
Reserved		DAC EN	PWR EN	BKP EN	Res.	CAN EN	Res.	USB EN	I2C2 EN	I2C1 EN	UART5 EN	UART4 EN	USART3 EN	USART2 EN	Res.
		rw	rw	rw		rw		rw	rw	rw	rw	rw	rw	rw	
15	14	13	12	11	10	9	8	7	6	5	4	3	2	1	0
SPI3 EN	SPI2 EN	Reserved		WWD GEN	Reserved		TIM14 EN	TIM13 EN	TIM12 EN	TIM7 EN	TIM6 EN	TIM5 EN	TIM4 EN	TIM3 EN	TIM2 EN
rw	rw			rw			rw	rw	rw	rw	rw	rw	rw	rw	rw

Bits 31:30 Reserved, always read as 0.

- Bit 29 **DACEN**: DAC interface clock enable  
Set and cleared by software.  
0: DAC interface clock disabled  
1: DAC interface clock enable

- Bit 28 **PWREN**: Power interface clock enable  
Set and cleared by software.  
0: Power interface clock disabled  
1: Power interface clock enable

- Bit 27 **BKPEN**: Backup interface clock enable  
Set and cleared by software.  
0: Backup interface clock disabled  
1: Backup interface clock enabled
- Bit 26 Reserved, always read as 0.
- Bit 25 **CANEN**: CAN clock enable  
Set and cleared by software.  
0: CAN clock disabled  
1: CAN clock enabled
- Bit 24 Reserved, always read as 0.
- Bit 23 **USBEN**: USB clock enable  
Set and cleared by software.  
0: USB clock disabled  
1: USB clock enabled
- Bit 22 **I2C2EN**: I2C 2 clock enable  
Set and cleared by software.  
0: I2C 2 clock disabled  
1: I2C 2 clock enabled
- Bit 21 **I2C1EN**: I2C 1 clock enable  
Set and cleared by software.  
0: I2C 1 clock disabled  
1: I2C 1 clock enabled
- Bit 20 **USART5EN**: USART 5 clock enable  
Set and cleared by software.  
0: USART 5 clock disabled  
1: USART 5 clock enabled
- Bit 19 **USART4EN**: USART 4 clock enable  
Set and cleared by software.  
0: USART 4 clock disabled  
1: USART 4 clock enabled
- Bit 18 **USART3EN**: USART 3 clock enable  
Set and cleared by software.  
0: USART 3 clock disabled  
1: USART 3 clock enabled
- Bit 17 **USART2EN**: USART 2 clock enable  
Set and cleared by software.  
0: USART 2 clock disabled  
1: USART 2 clock enabled
- Bits 16 Reserved, always read as 0.
- Bit 15 **SPI3EN**: SPI 3 clock enable  
Set and cleared by software.  
0: SPI 3 clock disabled  
1: SPI 3 clock enabled

Bit 14 **SPI2EN**: SPI 2 clock enable  
Set and cleared by software.  
0: SPI 2 clock disabled  
1: SPI 2 clock enabled

Bits 13:12 Reserved, always read as 0.

Bit 11 **WWDGEN**: Window watchdog clock enable  
Set and cleared by software.  
0: Window watchdog clock disabled  
1: Window watchdog clock enabled

Bits 10:9 Reserved, always read as 0.

Bit 8 **TIM14EN**: TIM14 timer clock enable  
Set and cleared by software.  
0: TIM14 clock disabled  
1: TIM14 clock enabled

Bit 7 **TIM13EN**: TIM13 timer clock enable  
Set and cleared by software.  
0: TIM13 clock disabled  
1: TIM13 clock enabled

Bit 6 **TIM12EN**: TIM12 timer clock enable  
Set and cleared by software.  
0: TIM12 clock disabled  
1: TIM12 clock enabled

Bit 5 **TIM7EN**: TIM7 timer clock enable  
Set and cleared by software.  
0: TIM7 clock disabled  
1: TIM7 clock enabled

Bit 4 **TIM6EN**: TIM6 timer clock enable  
Set and cleared by software.  
0: TIM6 clock disabled  
1: TIM6 clock enabled

Bit 3 **TIM5EN**: TIM5 timer clock enable  
Set and cleared by software.  
0: TIM5 clock disabled  
1: TIM5 clock enabled

Bit 2 **TIM4EN**: TIM4 timer clock enable  
Set and cleared by software.  
0: TIM4 clock disabled  
1: TIM4 clock enabled

Bit 1 **TIM3EN**: TIM3 timer clock enable  
Set and cleared by software.  
0: TIM3 clock disabled  
1: TIM3 clock enabled

Bit 0 **TIM2EN**: TIM2 timer clock enable  
Set and cleared by software.  
0: TIM2 clock disabled  
1: TIM2 clock enabled

### 6.3.9 Backup domain control register (RCC\_BDCR)

Address offset: 0x20

Reset value: 0x0000 0000, reset by Backup domain Reset.

Access: 0 ≤ wait state ≤ 3, word, half-word and byte access

Wait states are inserted in case of successive accesses to this register.

*Note:* The LSEON, LSEBYP, RTCSEL and RTCEN bits of the Backup domain control register (RCC\_BDCR) are in the Backup domain. As a result, after Reset, these bits are write-protected and the DBP bit in the Power control register (PWR\_CR) has to be set before these can be modified. Refer to Section 5 on page 73 for further information. These bits are only reset after a Backup domain Reset (see Section 6.1.3: Backup domain reset). Any internal or external Reset will not have any effect on these bits.

	31	30	29	28	27	26	25	24	23	22	21	20	19	18	17	16	
Reserved																BDRST	
																rw	
	15	14	13	12	11	10	9	8	7	6	5	4	3	2	1	0	
RTC EN	Reserved						RTCSEL[1:0]		Reserved						LSE BYP	LSE RDY	LSEON
rw							rw	rw							rw	r	rw

Bits 31:17 Reserved, always read as 0.

Bit 16 **BDRST**: Backup domain software reset

Set and cleared by software.

0: Reset not activated

1: Resets the entire Backup domain

Bit 15 **RTCEN**: RTC clock enable

Set and cleared by software.

0: RTC clock disabled

1: RTC clock enabled

Bits 14:10 Reserved, always read as 0.

Bits 9:8 **RTCSEL[1:0]**: RTC clock source selection

Set by software to select the clock source for the RTC. Once the RTC clock source has been selected, it cannot be changed anymore unless the Backup domain is reset. The BDRST bit can be used to reset them.

00: No clock

01: LSE oscillator clock used as RTC clock

10: LSI oscillator clock used as RTC clock

11: HSE oscillator clock divided by 128 used as RTC clock

Bits 7:3 Reserved, always read as 0.

Bit 2 **LSEBYP**: External low-speed oscillator bypass

Set and cleared by software to bypass oscillator in debug mode. This bit can be written only when the external 32 kHz oscillator is disabled.

0: LSE oscillator not bypassed

1: LSE oscillator bypassed

- Bit 1 **LSERDY**: External low-speed oscillator ready  
 Set and cleared by hardware to indicate when the external 32 kHz oscillator is stable. After the LSEON bit is cleared, LSERDY goes low after 6 external low-speed oscillator clock cycles.  
 0: External 32 kHz oscillator not ready  
 1: External 32 kHz oscillator ready
- Bit 0 **LSEON**: External low-speed oscillator enable  
 Set and cleared by software.  
 0: External 32 kHz oscillator OFF  
 1: External 32 kHz oscillator ON

### 6.3.10 Control/status register (RCC\_CSR)

Address: 0x24

Reset value: 0x0C00 0000, reset by system Reset, except reset flags by power Reset only.

Access: 0 ≤ wait state ≤ 3, word, half-word and byte access

Wait states are inserted in case of successive accesses to this register.

31	30	29	28	27	26	25	24	23	22	21	20	19	18	17	16		
LPWR RSTF	WWDG RSTF	IWDG RSTF	SFT RSTF	POR RSTF	PIN RSTF	Res.	RMVF	Reserved									
rw	rw	rw	rw	rw	rw		rw										
15	14	13	12	11	10	9	8	7	6	5	4	3	2	1	0		
Reserved													LSI RDY	LSION			
													r	rw			

- Bit 31 **LPWRRSTF**: Low-power reset flag  
 Set by hardware when a Low-power management reset occurs.  
 Cleared by writing to the RMVF bit.  
 0: No Low-power management reset occurred  
 1: Low-power management reset occurred  
 For further information on Low-power management reset, refer to [Low-power management reset](#).
- Bit 30 **WWDGRSTF**: Window watchdog reset flag  
 Set by hardware when a window watchdog reset occurs.  
 Cleared by writing to the RMVF bit.  
 0: No window watchdog reset occurred  
 1: Window watchdog reset occurred
- Bit 29 **IWDGRSTF**: Independent watchdog reset flag  
 Set by hardware when an independent watchdog reset from V<sub>DD</sub> domain occurs.  
 Cleared by writing to the RMVF bit.  
 0: No watchdog reset occurred  
 1: Watchdog reset occurred

- Bit 28 **SFTRSTF**: Software reset flag  
Set by hardware when a software reset occurs.  
Cleared by writing to the RMVF bit.  
0: No software reset occurred  
1: Software reset occurred
- Bit 27 **PORRSTF**: POR/PDR reset flag  
Set by hardware when a POR/PDR reset occurs.  
Cleared by writing to the RMVF bit.  
0: No POR/PDR reset occurred  
1: POR/PDR reset occurred
- Bit 26 **PINRSTF**: PIN reset flag  
Set by hardware when a reset from the NRST pin occurs.  
Cleared by writing to the RMVF bit.  
0: No reset from NRST pin occurred  
1: Reset from NRST pin occurred
- Bit 25 Reserved, always read as 0.
- Bit 24 **RMVF**: Remove reset flag  
Set by software to clear the reset flags.  
0: No effect  
1: Clear the reset flags
- Bits 23:2 Reserved, always read as 0.
- Bit 1 **LSIRDY**: Internal low-speed oscillator ready  
Set and cleared by hardware to indicate when the internal RC 40 kHz oscillator is stable.  
After the LSION bit is cleared, LSIRDY goes low after 3 internal RC 40 kHz oscillator clock cycles.  
0: Internal RC 40 kHz oscillator not ready  
1: Internal RC 40 kHz oscillator ready
- Bit 0 **LSION**: Internal low-speed oscillator enable  
Set and cleared by software.  
0: Internal RC 40 kHz oscillator OFF  
1: Internal RC 40 kHz oscillator ON

6.3.11 RCC register map

The following table gives the RCC register map and the reset values.

Table 16. RCC register map and reset values

Offset	Register	31	30	29	28	27	26	25	24	23	22	21	20	19	18	17	16	15	14	13	12	11	10	9	8	7	6	5	4	3	2	1	0							
0x000	RCC_CR	Reserved						PLL RDY	PLL ON	Reserved						CSSON	HSEBYP	HSERDY	HSEON	HSICAL[7:0]						HSITRIM[4:0]				Reserved	HSIRDY	HSION								
	Reset value							0	0							0	0	0	0	0	0	0	0	0	0	0	0	0	0	0	0	0	0	0	0	0	0	0		
0x004	RCC_CFGR	Reserved						MCO [2:0]		Reserved	USBPRE	PLLMUL[3:0]			CSSON	HSEBYP	HSERDY	HSEON	ADC PRE [1:0]	PPRE2 [2:0]	PPRE1 [2:0]	HPRE[3:0]			SWS [1:0]		SW [1:0]													
	Reset value							0	0	0	0	0	0	0	0	0	0	0	0	0	0	0	0	0	0	0	0	0	0	0	0	0	0	0	0	0	0	0		
0x008	RCC_CIR	Reserved						CSSC	Reserved						PLL RDY	HSEBYP	HSERDY	HSEON	Reserved						Reserved	HSIRDY	HSION													
	Reset value							0							0	0	0	0	0	0	0	0	0	0	0	0	0	0	0	0	0	0	0	0	0	0	0	0	0	
0x00C	RCC_APB2RSTR	Reserved						Reserved						TIM11RST	TIM10RST	TIM9RST	Reserved						ADC3RST	USART1RST	TIM8RST	SPI1RST	TIM1RST	ADC2RST	ADC1RST	IOPGRST	IOPFRST	IOPDRST	IOPCRST	IOPBRST	IOPARST	Reserved	AFIORST			
	Reset value													0	0	0							0	0	0	0	0	0	0	0	0	0	0	0	0	0	0	0	0	0
0x010	RCC_APB1RSTR	Reserved	DACRST	PWRST	BKPRST	Reserved	CANRST	Reserved	USBRST	I2C2RST	I2C1RST	UART5RST	UART4RST	USART3RST	USART2RST	Reserved						SPI3RST	SPI2RST	Reserved						WWDGRST	Reserved									
	Reset value	0	0	0	0	0	0	0	0	0	0	0	0	0	0							0	0							0										
0x014	RCC_AHBENR	Reserved						Reserved						Reserved						SIOEN	Reserved						FSMCEN	CRCCEN	FLITFEN	SRAMEN	DM2AEN	DM1AEN								
	Reset value																			0							0	0	0	0	0	0	0							
0x018	RCC_APB2ENR	Reserved						Reserved						TIM11EN	TIM10EN	TIM9EN	Reserved						ADC3EN	USART1EN	TIM8EN	SPI1EN	TIM1EN	ADC2EN	ADC1EN	IOPGEN	IOPFEN	IOPDEN	IOPCEN	IOPBEN	IOPAEN	Reserved	AFIOEN			
	Reset value													0	0	0							0	0	0	0	0	0	0	0	0	0	0	0	0	0	0	0		
0x01C	RCC_APB1ENR	Reserved	DACEN	PWREN	BKPEN	Reserved	CANEN	Reserved	USBEN	I2C2EN	I2C1EN	UART5EN	UART4EN	USART3EN	USART2EN	Reserved						SPI3EN	SPI2EN	Reserved						WWDGEN	Reserved									
	Reset value	0	0	0	0	0	0	0	0	0	0	0	0	0	0							0	0							0										
0x020	RCC_BDCR	Reserved						Reserved						Reserved						BDRST	RTCEN	Reserved						RTC SEL [1:0]		Reserved										
	Reset value																			0	0							0	0											
0x024	RCC_CSR	LPWRSTF	WWDGRSTF	IWDGRSTF	SFTRSTF	PORRSTF	PINRSTF	Reserved	RMVF	Reserved						Reserved						Reserved						Reserved						LSIRDY	LSION					
	Reset value	0	0	0	0	1	1	0	0																									0	0					

Refer to [Table 1 on page 44](#) for the register boundary addresses.

## 7 Connectivity line devices: reset and clock control (RCC)

**Low-density devices** are STM32F101xx, STM32F102xx and STM32F103xx microcontrollers where the Flash memory density ranges between 16 and 32 Kbytes.

**Medium-density devices** are STM32F101xx, STM32F102xx and STM32F103xx microcontrollers where the Flash memory density ranges between 64 and 128 Kbytes.

**High-density devices** are STM32F101xx and STM32F103xx microcontrollers where the Flash memory density ranges between 256 and 512 Kbytes.

**XL-density devices** are STM32F101xx and STM32F103xx microcontrollers where the Flash memory density ranges between 768 Kbytes and 1 Mbyte.

**Connectivity line devices** are STM32F105xx and STM32F107xx microcontrollers.

This Section applies to all connectivity line devices, unless otherwise specified.

### 7.1 Reset

There are three types of reset, defined as system reset, power reset and backup domain reset.

#### 7.1.1 System reset

A system reset sets all registers to their reset values except the reset flags in the clock controller CSR register and the registers in the Backup domain (see [Figure 4](#)).

A system reset is generated when one of the following events occurs:

1. A low level on the NRST pin (external reset)
2. Window watchdog end of count condition (WWDG reset)
3. Independent watchdog end of count condition (IWDG reset)
4. A software reset (SW reset) (see [Software reset](#))
5. Low-power management reset (see [Low-power management reset](#))

The reset source can be identified by checking the reset flags in the Control/Status register, RCC\_CSR (see [Section 7.3.10: Control/status register \(RCC\\_CSR\)](#)).

#### Software reset

The SYSRESETREQ bit in Cortex™-M3 Application Interrupt and Reset Control Register must be set to force a software reset on the device. Refer to the *STM32F10xxx Cortex-M3 programming manual* (see [Related documents on page 1](#)) for more details.



## Low-power management reset

There are two ways to generate a low-power management reset:

1. Reset generated when entering Standby mode:  
This type of reset is enabled by resetting nRST\_STDBY bit in User Option Bytes. In this case, whenever a Standby mode entry sequence is successfully executed, the device is reset instead of entering Standby mode.
2. Reset when entering Stop mode:  
This type of reset is enabled by resetting nRST\_STOP bit in User Option Bytes. In this case, whenever a Stop mode entry sequence is successfully executed, the device is reset instead of entering Stop mode.

For further information on the User Option Bytes, refer to the STM32F10xxx Flash programming manual.

## 7.1.2 Power reset

A power reset is generated when one of the following events occurs:

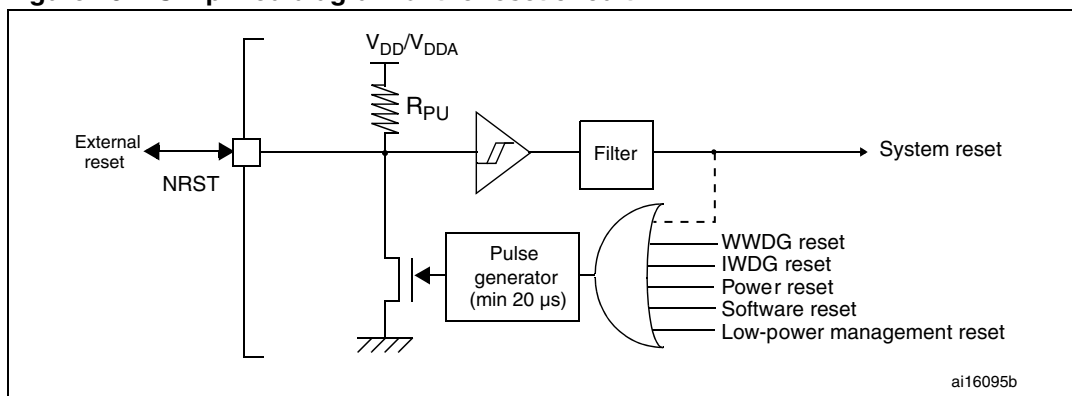
1. Power-on/power-down reset (POR/PDR reset)
2. When exiting Standby mode

A power reset sets all registers to their reset values except the Backup domain (see [Figure 4](#))

These sources act on the NRST pin and it is always kept low during the delay phase. The RESET service routine vector is fixed at address 0x0000\_0004 in the memory map. For more details, refer to [Table 61: Vector table for other STM32F10xxx devices on page 187](#).

The system reset signal provided to the device is output on the NRST pin. The pulse generator guarantees a minimum reset pulse duration of 20  $\mu$ s for each reset source (external or internal reset). In case of an external reset, the reset pulse is generated while the NRST pin is asserted low.

**Figure 10. Simplified diagram of the reset circuit**



### 7.1.3 Backup domain reset

The backup domain has two specific resets that affect only the backup domain (see [Figure 4](#)).

A backup domain reset is generated when one of the following events occurs:

1. Software reset, triggered by setting the BDRST bit in the [Backup domain control register \(RCC\\_BDCR\)](#).
2.  $V_{DD}$  or  $V_{BAT}$  power on, if both supplies have previously been powered off.

## 7.2 Clocks

Three different clock sources can be used to drive the system clock (SYSCLK):

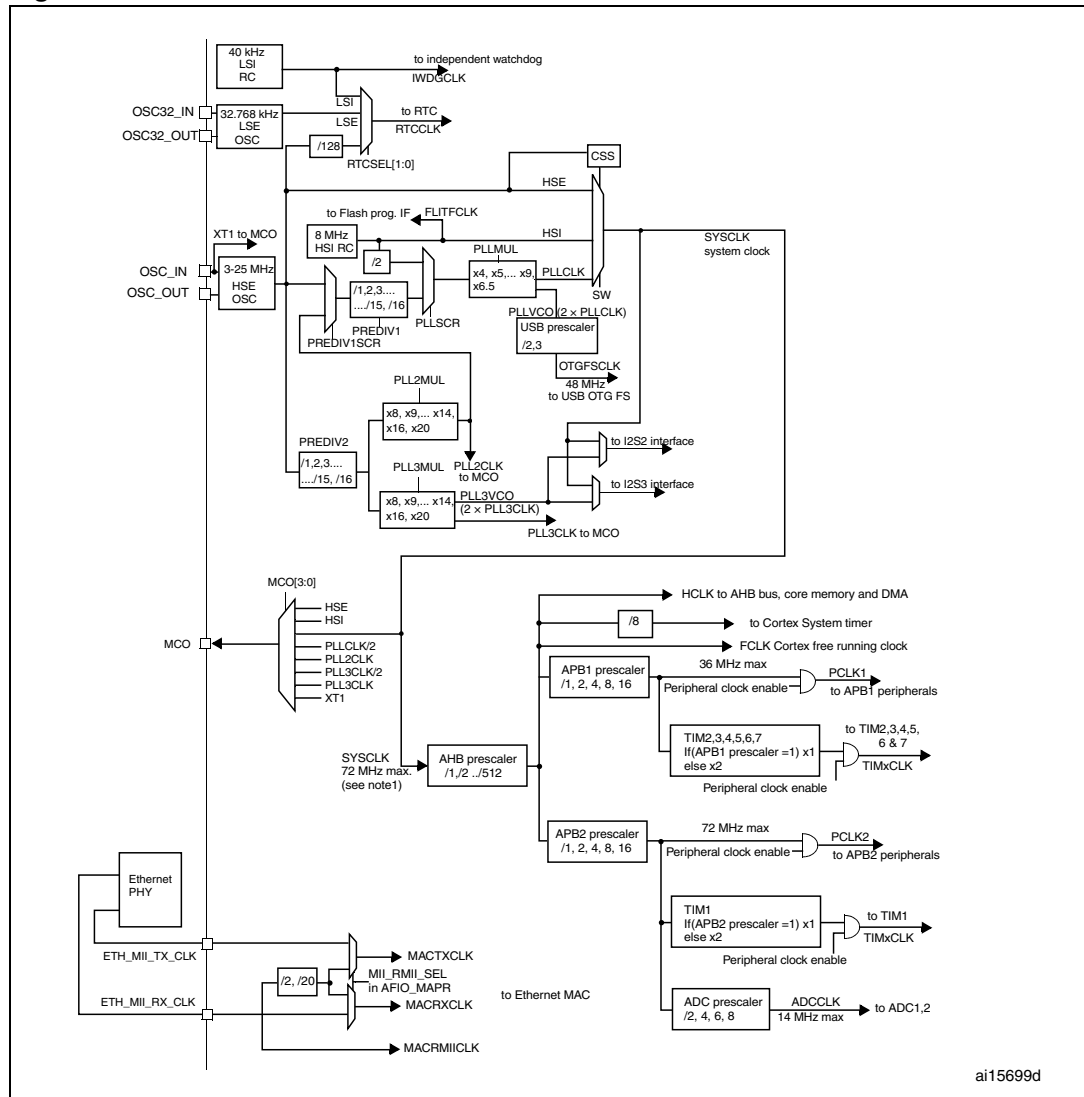
- HSI oscillator clock
- HSE oscillator clock
- PLL clock

The devices have the following two secondary clock sources:

- 40 kHz low speed internal RC (LSI RC) which drives the independent watchdog and optionally the RTC used for Auto-wakeup from Stop/Standby mode.
- 32.768 kHz low speed external crystal (LSE crystal) which optionally drives the real-time clock (RTCCLK)

Each clock source can be switched on or off independently when it is not used, to optimize power consumption.

Figure 11. Clock tree



1. When the HSI is used as a PLL clock input, the maximum system clock frequency that can be achieved is 36 MHz.
2. For full details about the internal and external clock source characteristics, please refer to the “Electrical characteristics” section in your device datasheet.

The advanced clock controller features 3 PLLs to provide a high degree of flexibility to the application in the choice of the external crystal or oscillator to run the core and peripherals at the highest frequency and guarantee the appropriate frequency for the Ethernet and USB OTG FS.

A single 25 MHz crystal can clock the entire system and all peripherals including the Ethernet and USB OTG FS peripherals. In order to achieve high-quality audio performance, an audio crystal can be used. In this case, the I2S master clock can generate all standard sampling frequencies from 8 kHz to 96 kHz with less than 0.5% accuracy.

For more details about clock configuration for applications requiring Ethernet, USB OTG FS and/or I<sup>2</sup>S (audio), please refer to "Appendix A Applicative block diagrams" in your connectivity line device datasheet.

Several prescalers allow the configuration of the AHB frequency, the high speed APB (APB2) and the low speed APB (APB1) domains. The maximum frequency of the AHB and the APB2 domains is 72 MHz. The maximum allowed frequency of the APB1 domain is 36 MHz.

All peripheral clocks are derived from the system clock (SYSCLK) except:

- The Flash memory programming interface clock which is always the HSI clock
- The USB OTG FS 48 MHz clock which is derived from the PLL VCO clock ( $2 \times$  PLLCLK), followed by a programmable prescaler (divide by 3 or 2). This selection is made through the OTGFSPRE bit in the RCC\_CFGR register. For proper USB OTG FS operation, the PLL should be configured to output 72 MHz or 48 MHz.
- The I2S2 and I2S3 clocks which can be derived from the system clock (SYSCLK) or the PLL3 VCO clock ( $2 \times$  PLL3CLK). This selection is made through the I2SxSRC bit in the RCC\_CFGR2 register. For more information on PLL3 and how to configure the I2S clock to achieve high-quality audio performance, please refer to [Section 24.4.3: Clock generator](#).
- The Ethernet MAC clocks (TX, RX and RMII) which are provided from the external PHY. For further information on the Ethernet configuration, please refer to [Section 28.4.4: MII/RMII selection](#).

When the Ethernet is used, the AHB clock frequency must be at least 25 MHz.

The RCC feeds the Cortex System Timer (SysTick) external clock with the AHB clock (HCLK) divided by 8. The SysTick can work either with this clock or with the Cortex clock (HCLK), configurable in the SysTick Control and Status Register. The ADCs are clocked by the clock of the High Speed domain (APB2) divided by 2, 4, 6 or 8.

The timer clock frequencies are automatically fixed by hardware. There are two cases:

1. if the APB prescaler is 1, the timer clock frequencies are set to the same frequency as that of the APB domain to which the timers are connected.
2. otherwise, they are set to twice ( $\times 2$ ) the frequency of the APB domain to which the timers are connected.

FCLK acts as Cortex<sup>TM</sup>-M3's free-running clock. For more details refer to the ARM [Cortex<sup>TM</sup>-M3 r1p1 Technical Reference Manual \(TRM\)](#).

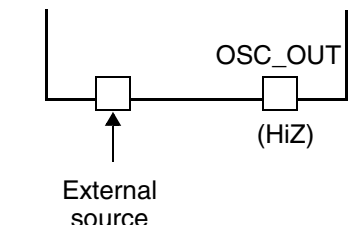
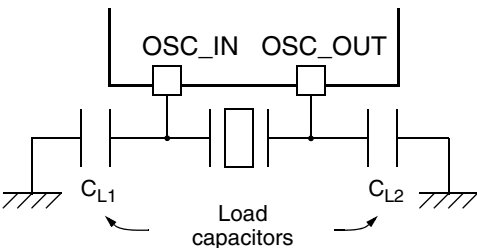
## 7.2.1 HSE clock

The high speed external clock signal (HSE) can be generated from two possible clock sources:

- HSE external crystal/ceramic resonator
- HSE user external clock

The resonator and the load capacitors have to be placed as close as possible to the oscillator pins in order to minimize output distortion and startup stabilization time. The loading capacitance values must be adjusted according to the selected oscillator.

Figure 12. HSE/ LSE clock sources

Clock source	Hardware configuration
External clock	
Crystal/ceramic resonators	

**External source (HSE bypass)**

In this mode, an external clock source must be provided. It can have a frequency of up to 50 MHz. You select this mode by setting the HSEBYP and HSEON bits in the *Clock control register (RCC\_CR)*. The external clock signal (square, sinus or triangle) with ~50% duty cycle has to drive the OSC\_IN pin while the OSC\_OUT pin should be left hi-Z. See *Figure 12*.

**External crystal/ceramic resonator (HSE crystal)**

The 3 to 25 MHz external oscillator has the advantage of producing a very accurate rate on the main clock.

The associated hardware configuration is shown in *Figure 12*. Refer to the electrical characteristics section of the *datasheet* for more details.

The HSERDY flag in the *Clock control register (RCC\_CR)* indicates if the high-speed external oscillator is stable or not. At startup, the clock is not released until this bit is set by hardware. An interrupt can be generated if enabled in the *Clock interrupt register (RCC\_CIR)*.

The HSE crystal can be switched on and off using the HSEON bit in the *Clock control register (RCC\_CR)*.

**7.2.2 HSI clock**

The HSI clock signal is generated from an internal 8 MHz RC Oscillator and can be used directly as a system clock or divided by 2 to be used as PLL input.

The HSI RC oscillator has the advantage of providing a clock source at low cost (no external components). It also has a faster startup time than the HSE crystal oscillator however, even with calibration the frequency is less accurate than an external crystal oscillator or ceramic resonator.

## Calibration

RC oscillator frequencies can vary from one chip to another due to manufacturing process variations, this is why each device is factory calibrated by ST for 1% accuracy at  $T_A = 25\text{ }^\circ\text{C}$ .

After reset, the factory calibration value is loaded in the HSICAL[7:0] bits in the [Clock control register \(RCC\\_CR\)](#).

If the application is subject to voltage or temperature variations this may affect the RC oscillator speed. You can trim the HSI frequency in the application using the HSITRIM[4:0] bits in the [Clock control register \(RCC\\_CR\)](#).

The HSIRDY flag in the [Clock control register \(RCC\\_CR\)](#) indicates if the HSI RC is stable or not. At startup, the HSI RC output clock is not released until this bit is set by hardware.

The HSI RC can be switched on and off using the HSION bit in the [Clock control register \(RCC\\_CR\)](#).

The HSI signal can also be used as a backup source (Auxiliary clock) if the HSE crystal oscillator fails. Refer to [Section 7.2.7: Clock security system \(CSS\) on page 120](#).

## 7.2.3 PLLs

The main PLL provides a frequency multiplier starting from one of the following clock sources:

- HSI clock divided by 2
- HSE or PLL2 clock through a configurable divider

Refer to [Figure 11](#) and [Clock control register \(RCC\\_CR\)](#).

PLL2 and PLL3 are clocked by HSE through a specific configurable divider. Refer to [Figure 11](#) and [Clock configuration register2 \(RCC\\_CFGR2\)](#)

The configuration of each PLL (selection of clock source, predivision factor and multiplication factor) must be done before enabling the PLL. Each PLL should be enabled after its input clock becomes stable (ready flag). Once the PLL is enabled, these parameters can not be changed.

When changing the entry clock source of the main PLL, the original clock source must be switched off only after the selection of the new clock source (done through bit PLLSRC in the Clock configuration register (RCC\_CFGR)).

An interrupt can be generated when the PLL is ready if enabled in the [Clock interrupt register \(RCC\\_CIR\)](#).

## 7.2.4 LSE clock

The LSE crystal is a 32.768 kHz Low Speed External crystal or ceramic resonator. It has the advantage providing a low-power but highly accurate clock source to the real-time clock peripheral (RTC) for clock/calendar or other timing functions.

The LSE crystal is switched on and off using the LSEON bit in [Backup domain control register \(RCC\\_BDCR\)](#).

The LSEIRDY flag in the [Backup domain control register \(RCC\\_BDCR\)](#) indicates if the LSE crystal is stable or not. At startup, the LSE crystal output clock signal is not released until this bit is set by hardware. An interrupt can be generated if enabled in the [Clock interrupt register \(RCC\\_CIR\)](#).

### External source (LSE bypass)

In this mode, an external clock source must be provided. It can have a frequency of up to 1 MHz. You select this mode by setting the LSEBYP and LSEON bits in the *Backup domain control register (RCC\_BDCR)*. The external clock signal (square, sinus or triangle) with ~50% duty cycle has to drive the OSC32\_IN pin while the OSC32\_OUT pin should be left Hi-Z. See *Figure 12*.

### 7.2.5 LSI clock

The LSI RC acts as an low-power clock source that can be kept running in Stop and Standby mode for the independent watchdog (IWDG) and Auto-wakeup unit (AWU). The clock frequency is around 40 kHz (between 30 kHz and 60 kHz). For more details, refer to the electrical characteristics section of the datasheets.

The LSI RC can be switched on and off using the LSION bit in the *Control/status register (RCC\_CSR)*.

The LSIRDY flag in the *Control/status register (RCC\_CSR)* indicates if the low-speed internal oscillator is stable or not. At startup, the clock is not released until this bit is set by hardware. An interrupt can be generated if enabled in the *Clock interrupt register (RCC\_CIR)*.

#### LSI calibration

The frequency dispersion of the Low Speed Internal RC (LSI) oscillator can be calibrated to have accurate RTC time base and/or IWDG timeout (when LSI is used as clock source for these peripherals) with an acceptable accuracy.

This calibration is performed by measuring the LSI clock frequency with respect to TIM5 input clock (TIM5CLK). According to this measurement done at the precision of the HSE oscillator, the software can adjust the programmable 20-bit prescaler of the RTC to get an accurate time base or can compute accurate IWDG timeout.

Use the following procedure to calibrate the LSI:

1. Enable TIM5 timer and configure channel4 in input capture mode
2. Set the TIM5CH4\_IREMAP bit in the AFIO\_MAPR register to connect the LSI clock internally to TIM5 channel4 input capture for calibration purpose.
3. Measure the frequency of LSI clock using the TIM5 Capture/compare 4 event or interrupt.
4. Use the measured LSI frequency to update the 20-bit prescaler of the RTC depending on the desired time base and/or to compute the IWDG timeout.

### 7.2.6 System clock (SYSCLK) selection

After a system reset, the HSI oscillator is selected as system clock. When a clock source is used directly or through the PLL as the system clock, it is not possible to stop it.

A switch from one clock source to another occurs only if the target clock source is ready (clock stable after startup delay or PLL locked). If a clock source which is not yet ready is selected, the switch will occur when the clock source will be ready. Status bits in the *Clock control register (RCC\_CR)* indicate which clock(s) is (are) ready and which clock is currently used as system clock.

### 7.2.7 Clock security system (CSS)

Clock Security System can be activated by software. In this case, the clock detector is enabled after the HSE oscillator startup delay, and disabled when this oscillator is stopped.

If a failure is detected on the HSE oscillator clock, this oscillator is automatically disabled, a clock failure event is sent to the break input of the TIM1 Advanced control timer and an interrupt is generated to inform the software about the failure (Clock Security System Interrupt CSSI), allowing the MCU to perform rescue operations. The CSSI is linked to the Cortex™-M3 NMI (Non-Maskable Interrupt) exception vector.

*Note:* Once the CSS is enabled and if the HSE clock fails, the CSS interrupt occurs and an NMI is automatically generated. The NMI will be executed indefinitely unless the CSS interrupt pending bit is cleared. As a consequence, in the NMI ISR user must clear the CSS interrupt by setting the CSSC bit in the [Clock interrupt register \(RCC\\_CIR\)](#).

If the HSE oscillator is used directly or indirectly as the system clock (indirectly means: it is used as PLL input clock directly or through PLL2, and the PLL clock is used as system clock), a detected failure causes a switch of the system clock to the HSI oscillator and the disabling of the external HSE oscillator. If the HSE oscillator clock is the clock entry of the PLL (directly or through PLL2) used as system clock when the failure occurs, the PLL is disabled too.

### 7.2.8 RTC clock

The RTCCLK clock source can be either the HSE/128, LSE or LSI clocks. This is selected by programming the RTCSEL[1:0] bits in the [Backup domain control register \(RCC\\_BDCR\)](#). This selection cannot be modified without resetting the Backup domain.

The LSE clock is in the Backup domain, whereas the HSE and LSI clocks are not. Consequently:

- If LSE is selected as RTC clock:
  - The RTC continues to work even if the  $V_{DD}$  supply is switched off, provided the  $V_{BAT}$  supply is maintained.
- If LSI is selected as Auto-Wakeup unit (AWU) clock:
  - The AWU state is not guaranteed if the  $V_{DD}$  supply is powered off. Refer to [Section 7.2.5: LSI clock on page 119](#) for more details on LSI calibration.
- If the HSE clock divided by 128 is used as RTC clock:
  - The RTC state is not guaranteed if the  $V_{DD}$  supply is powered off or if the internal voltage regulator is powered off (removing power from the 1.8 V domain).
  - The DPB bit (Disable backup domain write protection) in the Power controller register must be set to 1 (refer to [Section 4.4.1: Power control register \(PWR\\_CR\)](#)).

### 7.2.9 Watchdog clock

If the Independent watchdog (IWDG) is started by either hardware option or software access, the LSI oscillator is forced ON and cannot be disabled. After the LSI oscillator temporization, the clock is provided to the IWDG.



### 7.2.10 Clock-out capability

The microcontroller clock output (MCO) capability allows the clock to be output onto the external MCO pin. The configuration registers of the corresponding GPIO port must be programmed in alternate function mode. One of 8 clock signals can be selected as the MCO clock.

- SYCLK
- HSI
- HSE
- PLL clock divided by 2 selected
- PLL2 clock selected
- PLL3 clock divided by 2 selected
- XT1 external 3-25 MHz oscillator clock selected (for Ethernet)
- PLL3 clock selected (for Ethernet)

The selected clock to output onto MCO must not exceed 50 MHz (the maximum I/O speed).

The selection is controlled by the MCO[3:0] bits of the *Clock configuration register (RCC\_CFGR)*.

## 7.3 RCC registers

Refer to *Section 1.1 on page 40* for a list of abbreviations used in register descriptions.

### 7.3.1 Clock control register (RCC\_CR)

Address offset: 0x00

Reset value: 0x0000 XX83 where X is undefined.

Access: no wait state, word, half-word and byte access

31	30	29	28	27	26	25	24	23	22	21	20	19	18	17	16	
Reserved		PLL3 RDY	PLL3 ON	PLL2 RDY	PLL2 ON	PLL3RDY	PLLON	Reserved				CSSON	HSEBYP	HSERDY	HSEON	
		r	rw	r	rw	r	rw					rw	rw	r	rw	
15	14	13	12	11	10	9	8	7	6	5	4	3	2	1	0	
HSICAL[7:0]							HSITRIM[4:0]					Res.		HSIRDY	HSION	
r	r	r	r	r	r	r	r	rw	rw	rw	rw	rw			r	rw

Bits 31:30 Reserved, always read as 0.

Bit 29 **PLL3RDY**: PLL3 clock ready flag

Set by hardware to indicate that the PLL3 is locked.

0: PLL3 unlocked

1: PLL3 locked

Bit 28 **PLL3ON**: PLL3 enable

Set and cleared by software to enable PLL3.

Cleared by hardware when entering Stop or Standby mode.

0: PLL3 OFF

1: PLL3 ON

- Bit 27 **PLL2RDY**: PLL2 clock ready flag  
Set by hardware to indicate that the PLL2 is locked.  
0: PLL2 unlocked  
1: PLL2 locked
- Bit 26 **PLL2ON**: PLL2 enable  
Set and cleared by software to enable PLL2.  
Cleared by hardware when entering Stop or Standby mode. This bit can not be cleared if the PLL2 clock is used indirectly as system clock (i.e. it is used as PLL clock entry that is used as system clock).  
0: PLL2 OFF  
1: PLL2 ON
- Bit 25 **PLL2RDY**: PLL clock ready flag  
Set by hardware to indicate that the PLL is locked.  
0: PLL unlocked  
1: PLL locked
- Bit 24 **PLLON**: PLL enable  
Set and cleared by software to enable PLL.  
Cleared by hardware when entering Stop or Standby mode. This bit can not be reset if the PLL clock is used as system clock or is selected to become the system clock. Software must disable the USB OTG FS clock before clearing this bit.  
0: PLL OFF  
1: PLL ON
- Bits 23:20 Reserved, always read as 0.
- Bit 19 **CSSON**: Clock security system enable  
Set and cleared by software to enable clock detector.  
0: Clock detector OFF  
1: Clock detector ON if external 3-25 MHz oscillator is ready.
- Bit 18 **HSEBYP**: External high-speed clock bypass  
Set and cleared by software for bypassing the oscillator with an external clock. This bit can be written only if the external 3-25 MHz oscillator is disabled.  
0: external 3-25 MHz oscillator not bypassed  
1: external 3-25 MHz oscillator bypassed with external clock
- Bit 17 **HSERDY**: External high-speed clock ready flag  
Set by hardware to indicate that the external 3-25 MHz oscillator is stable. This bit needs 6 cycles of external 3-25 MHz oscillator clock to fall down after HSEON reset.  
0: external 3-25 MHz oscillator not ready  
1: external 3-25 MHz oscillator ready
- Bit 16 **HSEON**: External high-speed clock enable  
Set and cleared by software.  
Cleared by hardware to stop the external 3-25MHz oscillator when entering Stop or Standby mode. This bit can not be reset if the external 3-25 MHz oscillator is used directly or indirectly as system clock or is selected to become the system clock.  
0: HSE oscillator OFF  
1: HSE oscillator ON
- Bits 15:8 **HSICAL[7:0]**: Internal high-speed clock calibration  
These bits are initialized automatically at startup.

Bits 7:3 **HSITRIM[4:0]**: Internal high-speed clock trimming

These bits provide an additional user-programmable trimming value that is added to the HSICAL[7:0] bits. It can be programmed to adjust to variations in voltage and temperature that influence the frequency of the internal HSI RC.

The default value is 16, which, when added to the HSICAL value, should trim the HSI to 8 MHz ± 1%. The trimming step ( $F_{hsitrim}$ ) is around 40 kHz between two consecutive HSICAL steps.

Bit 2 Reserved, always read as 0.

Bit 1 **HSIRDY**: Internal high-speed clock ready flag

Set by hardware to indicate that internal 8 MHz RC oscillator is stable. After the HSION bit is cleared, HSIRDY goes low after 6 internal 8 MHz RC oscillator clock cycles.

0: Internal 8 MHz RC oscillator not ready

1: Internal 8 MHz RC oscillator ready

Bit 0 **HSION**: Internal high-speed clock enable

Set and cleared by software.

Set by hardware to force the internal 8 MHz RC oscillator ON when leaving Stop or Standby mode or in case of failure of the external 3-25 MHz oscillator used directly or indirectly as system clock. This bit can not be cleared if the internal 8 MHz RC is used directly or indirectly as system clock or is selected to become the system clock.

0: Internal 8 MHz RC oscillator OFF

1: Internal 8 MHz RC oscillator ON

### 7.3.2 Clock configuration register (RCC\_CFGR)

Address offset: 0x04

Reset value: 0x0000 0000

Access: 0 ≤ wait state ≤ 2, word, half-word and byte access

1 or 2 wait states inserted only if the access occurs during a clock source switch.

Reserved				MCO[3:0]				Res.	OTGFS PRE	PLLMUL[3:0]				PLL XTPRE	PLL SRC
r	w	r	w	r	w	r	w		r	r	r	r	r	r	r
31	30	29	28	27	26	25	24	23	22	21	20	19	18	17	16
ADC PRE[1:0]		PPRE2[2:0]			PPRE1[2:0]			HPRE[3:0]				SWS[1:0]		SW[1:0]	
r	w	r	w	r	w	r	w	r	r	r	r	r	r	r	w
15	14	13	12	11	10	9	8	7	6	5	4	3	2	1	0

Bits 31:27 Reserved, always read as 0.

Bits 26:24 **MCO[3:0]**: Microcontroller clock output

Set and cleared by software.

00xx: No clock

0100: System clock (SYSCLK) selected

0101: HSI clock selected

0110: HSE clock selected

0111: PLL clock divided by 2 selected

1000: PLL2 clock selected

1001: PLL3 clock divided by 2 selected

1010: XT1 external 3-25 MHz oscillator clock selected (for Ethernet)

1011: PLL3 clock selected (for Ethernet)

*Note: This clock output may have some truncated cycles at startup or during MCO clock source switching.*

*The selected clock to output onto the MCO pin must not exceed 50 MHz (the maximum I/O speed).*

Bit 22 **OTGFSPRE**: USB OTG FS prescaler

Set and cleared by software to generate the 48 MHz USB OTG FS clock. This bit must be valid before enabling the OTG FS clock in the RCC\_APB1ENR register. This bit can not be cleared if the OTG FS clock is enabled.

0: PLL VCO (2 × PLLCLK) clock is divided by 3 (PLL must be configured to output 72 MHz)

1: PLL VCO (2 × PLLCLK) clock is divided by 2 (PLL must be configured to output 48 MHz)

Bits 21:18 **PLLMUL[3:0]**: PLL multiplication factor

These bits are written by software to define the PLL multiplication factor. They can be written only when PLL is disabled.

000x: Reserved

0010: PLL input clock x 4

0011: PLL input clock x 5

0100: PLL input clock x 6

0101: PLL input clock x 7

0110: PLL input clock x 8

0111: PLL input clock x 9

10xx: Reserved

1100: Reserved

1101: PLL input clock x 6.5

111x: Reserved

**Caution:** The PLL output frequency must not exceed 72 MHz.

Bit 17 **PLLXTPRE**: LSB of division factor PREDIV1

Set and cleared by software to select the least significant bit of the PREDIV1 division factor. It is the same bit as bit(0) in the RCC\_CFGR2 register, so modifying bit(0) in the RCC\_CFGR2 register changes this bit accordingly.

If bits[3:1] in register RCC\_CFGR2 are not set, this bit controls if PREDIV1 divides its input clock by 2 (PLLXTPRE=1) or not (PLLXTPRE=0).

This bit can be written only when PLL is disabled.

Bit 16 **PLLSRC**: PLL entry clock source

Set and cleared by software to select PLL clock source. This bit can be written only when PLL is disabled.

0: HSI oscillator clock / 2 selected as PLL input clock

1: Clock from PREDIV1 selected as PLL input clock

*Note: When changing the main PLL's entry clock source, the original clock source must be switched off only after the selection of the new clock source.*

Bits 14:14 **ADCPRE[1:0]**: ADC prescaler

Set and cleared by software to select the frequency of the clock to the ADCs.

00: PCLK2 divided by 2

01: PCLK2 divided by 4

10: PCLK2 divided by 6

11: PCLK2 divided by 8

Bits 13:11 **PPRE2[2:0]**: APB high-speed prescaler (APB2)

Set and cleared by software to control the division factor of the APB High speed clock (PCLK2).

0xx: HCLK not divided

100: HCLK divided by 2

101: HCLK divided by 4

110: HCLK divided by 8

111: HCLK divided by 16

Bits 10:8 **PPRE1[2:0]**: APB Low-speed prescaler (APB1)

Set and cleared by software to control the division factor of the APB Low speed clock (PCLK1).

0xx: HCLK not divided

100: HCLK divided by 2

101: HCLK divided by 4

110: HCLK divided by 8

111: HCLK divided by 16

**Caution:** Software must configure these bits ensure that the frequency in this domain does not exceed 36 MHz.

Bits 7:4 **HPRE[3:0]**: AHB prescaler

Set and cleared by software to control AHB clock division factor.

0xxx: SYSCLK not divided

1000: SYSCLK divided by 2

1001: SYSCLK divided by 4

1010: SYSCLK divided by 8

1011: SYSCLK divided by 16

1100: SYSCLK divided by 64

1101: SYSCLK divided by 128

1110: SYSCLK divided by 256

1111: SYSCLK divided by 512

*Note:* The prefetch buffer must be kept on when using a prescaler different from 1 on the AHB clock. Refer to the section [Reading the Flash memory on page 52](#) for more details.

**Caution:** The AHB clock frequency must be at least 25 MHz when the Ethernet is used.

Bits 3:2 **SWS[1:0]**: System clock switch status

Set and cleared by hardware to indicate which clock source is used as system clock.

00: HSI oscillator used as system clock

01: HSE oscillator used as system clock

10: PLL used as system clock

11: Not applicable

Bits 1:0 **SW[1:0]**: System clock Switch

Set and cleared by software to select SYSCLK source.

Set by hardware to force HSI selection when leaving Stop and Standby mode or in case of failure of the HSE oscillator used directly or indirectly as system clock (if the Clock Security System is enabled).

00: HSI selected as system clock

01: HSE selected as system clock

10: PLL selected as system clock

11: Not allowed

### 7.3.3 Clock interrupt register (RCC\_CIR)

Address offset: 0x08

Reset value: 0x0000 0000

Access: no wait state, word, half-word and byte access

31	30	29	28	27	26	25	24	23	22	21	20	19	18	17	16
Reserved								CSSC	PLL3 RDYC	PLL2 RDYC	PLL RDYC	HSE RDYC	HSI RDYC	LSE RDYC	LSI RDYC
								w	w	w	w	w	w	w	w
15	14	13	12	11	10	9	8	7	6	5	4	3	2	1	0
Res.	PLL3 RDYIE	PLL2 RDYIE	PLL RDYIE	HSE RDYIE	HSI RDYIE	LSE RDYIE	LSI RDYIE	CSSF	PLL3 RDYF	PLL2 RDYF	PLL RDYF	HSE RDYF	HSI RDYF	LSE RDYF	LSI RDYF
	rw	rw	rw	rw	rw	rw	rw	r	r	r	r	r	r	r	r

Bits 31:24 Reserved, always read as 0.

Bit 23 **CSSC**: Clock security system interrupt clear

This bit is set by software to clear the CSSF flag.

0: No effect

1: Clear CSSF flag

Bit 22 **PLL3RDYC**: PLL3 Ready Interrupt Clear

This bit is set by software to clear the PLL3RDYF flag.

0: No effect

1: Clear PLL3RDYF flag

Bit 21 **PLL2RDYC**: PLL2 Ready Interrupt Clear

This bit is set by software to clear the PLL2RDYF flag.

0: No effect

1: Clear PLL2RDYF flag

Bit 20 **PLLRDYC**: PLL ready interrupt clear

This bit is set by software to clear the PLLRDYF flag.

0: No effect

1: Clear PLLRDYF flag

Bit 19 **HSERDYC**: HSE ready interrupt clear

This bit is set by software to clear the HSERDYF flag.

0: No effect

1: Clear HSERDYF flag

- Bit 18 **HSIRDYC**: HSI ready interrupt clear  
This bit is set by software to clear the HSIRDYF flag.  
0: No effect  
1: Clear HSIRDYF flag
- Bit 17 **LSERDYC**: LSE ready interrupt clear  
This bit is set by software to clear the LSERDYF flag.  
0: No effect  
1: Clear LSERDYF flag
- Bit 16 **LSIRDYC**: LSI ready interrupt clear  
This bit is set by software to clear the LSIRDYF flag.  
0: No effect  
1: Clear LSIRDYF flag
- Bit 15 Reserved, always read as 0.
- Bit 14 **PLL3RDYIE**: PLL3 Ready Interrupt Enable  
Set and cleared by software to enable/disable interrupt caused by PLL3 lock.  
0: PLL3 lock interrupt disabled  
1: PLL3 lock interrupt enabled
- Bit 13 **PLL2RDYIE**: PLL2 Ready Interrupt Enable  
Set and cleared by software to enable/disable interrupt caused by PLL2 lock.  
0: PLL2 lock interrupt disabled  
1: PLL2 lock interrupt enabled
- Bit 12 **PLLRDYIE**: PLL ready interrupt enable  
Set and cleared by software to enable/disable interrupt caused by PLL lock.  
0: PLL lock interrupt disabled  
1: PLL lock interrupt enabled
- Bit 11 **HSERDYIE**: HSE ready interrupt enable  
Set and cleared by software to enable/disable interrupt caused by the external 3-25 MHz oscillator stabilization.  
0: HSE ready interrupt disabled  
1: HSE ready interrupt enabled
- Bit 10 **HSIRDYIE**: HSI ready interrupt enable  
Set and cleared by software to enable/disable interrupt caused by the internal 8 MHz RC oscillator stabilization.  
0: HSI ready interrupt disabled  
1: HSI ready interrupt enabled
- Bit 9 **LSERDYIE**: LSE ready interrupt enable  
Set and cleared by software to enable/disable interrupt caused by the external 32 kHz oscillator stabilization.  
0: LSE ready interrupt disabled  
1: LSE ready interrupt enabled
- Bit 8 **LSIRDYIE**: LSI ready interrupt enable  
Set and cleared by software to enable/disable interrupt caused by internal RC 40 kHz oscillator stabilization.  
0: LSI ready interrupt disabled  
1: LSI ready interrupt enabled

- Bit 7 **CSSF**: Clock security system interrupt flag  
Set by hardware when a failure is detected in the external 3-25 MHz oscillator. It is cleared by software setting the CSSC bit.  
0: No clock security interrupt caused by HSE clock failure  
1: Clock security interrupt caused by HSE clock failure
- Bit 6 **PLL3RDYF**: PLL3 Ready Interrupt flag  
Set by hardware when the PLL3 locks and PLL3RDYIE is set. It is cleared by software setting the PLL3RDYC bit.  
0: No clock ready interrupt caused by PLL3 lock  
1: Clock ready interrupt caused by PLL3 lock
- Bit 5 **PLL2RDYF**: PLL2 Ready Interrupt flag  
Set by hardware when the PLL2 locks and PLL2RDYIE is set. It is cleared by software setting the PLL2RDYC bit.  
0: No clock ready interrupt caused by PLL2 lock  
1: Clock ready interrupt caused by PLL2 lock
- Bit 4 **PLLRDYF**: PLL ready interrupt flag  
Set by hardware when the PLL locks and PLLRDYIE is set. It is cleared by software setting the PLLRDYC bit.  
0: No clock ready interrupt caused by PLL lock  
1: Clock ready interrupt caused by PLL lock
- Bit 3 **HSERDYF**: HSE ready interrupt flag  
Set by hardware when External Low Speed clock becomes stable and HSERDYIE is set. It is cleared by software setting the HSERDYC bit.  
0: No clock ready interrupt caused by the external 3-25 MHz oscillator  
1: Clock ready interrupt caused by the external 3-25 MHz oscillator
- Bit 2 **HSIRDYF**: HSI ready interrupt flag  
Set by hardware when the Internal High Speed clock becomes stable and HSIRDYIE is set. It is cleared by software setting the HSIRDYC bit.  
0: No clock ready interrupt caused by the internal 8 MHz RC oscillator  
1: Clock ready interrupt caused by the internal 8 MHz RC oscillator
- Bit 1 **LSERDYF**: LSE ready interrupt flag  
Set by hardware when the External Low Speed clock becomes stable and LSERDYIE is set. It is cleared by software setting the LSERDYC bit.  
0: No clock ready interrupt caused by the external 32 kHz oscillator  
1: Clock ready interrupt caused by the external 32 kHz oscillator
- Bit 0 **LSIRDYF**: LSI ready interrupt flag  
Set by hardware when Internal Low Speed clock becomes stable and LSIRDYIE is set. It is cleared by software setting the LSIRDYC bit.  
0: No clock ready interrupt caused by the internal RC 40 kHz oscillator  
1: Clock ready interrupt caused by the internal RC 40 kHz oscillator



### 7.3.4 APB2 peripheral reset register (RCC\_APB2RSTR)

Address offset: 0x0C

Reset value: 0x00000 0000

Access: no wait state, word, half-word and byte access

31	30	29	28	27	26	25	24	23	22	21	20	19	18	17	16	
Reserved																
15	14	13	12	11	10	9	8	7	6	5	4	3	2	1	0	
Res.	USART1 RST	Res.	SPI1 RST	TIM1 RST	ADC2 RST	ADC1 RST	Reserved			IOPE RST	IOPD RST	IOPC RST	IOPB RST	IOPA RST	Res.	AFIO RST
	rw		rw	rw	rw	rw				rw	rw	rw	rw	rw		rw

Bits 31:15 Reserved, always read as 0.

Bit 14 **USART1RST**: USART1 reset  
Set and cleared by software.  
0: No effect  
1: Reset USART1

Bit 13 Reserved, always read as 0.

Bit 12 **SPI1RST**: SPI 1 reset  
Set and cleared by software.  
0: No effect  
1: Reset SPI 1

Bit 11 **TIM1RST**: TIM1 timer reset  
Set and cleared by software.  
0: No effect  
1: Reset TIM1 timer

Bit 10 **ADC2RST**: ADC 2 interface reset  
Set and cleared by software.  
0: No effect  
1: Reset ADC 2 interface

Bit 9 **ADC1RST**: ADC 1 interface reset  
Set and cleared by software.  
0: No effect  
1: Reset ADC 1 interface

Bits 8:7 Reserved, always read as 0.

Bit 6 **IOPERST**: I/O port E reset  
Set and cleared by software.  
0: No effect  
1: Reset I/O port E

Bit 5 **IOPDRST**: I/O port D reset  
Set and cleared by software.  
0: No effect  
1: Reset I/O port D

- Bit 4 **IOPCRST**: IO port C reset  
Set and cleared by software.  
0: No effect  
1: Reset I/O port C
- Bit 3 **IOPBRST**: IO port B reset  
Set and cleared by software.  
0: No effect  
1: Reset I/O port B
- Bit 2 **IOPARST**: I/O port A reset  
Set and cleared by software.  
0: No effect  
1: Reset I/O port A
- Bit 1 Reserved, always read as 0.
- Bit 0 **AFIORST**: Alternate function I/O reset  
Set and cleared by software.  
0: No effect  
1: Reset Alternate Function

### 7.3.5 APB1 peripheral reset register (RCC\_APB1RSTR)

Address offset: 0x10

Reset value: 0x0000 0000

Access: no wait state, word, half-word and byte access

31		30		29		28		27		26		25		24		23		22		21		20		19		18		17		16	
Reserved				DAC RST	PWR RST	BKP RST	CAN2 RST	CAN1 RST	Reserved				I2C2 RST	I2C1 RST	UART 5 RST	UART 4 RST	USART 3 RST	USART 2 RST	Res.												
				rw	rw	rw	rw	rw					rw	rw	rw	rw	rw	rw													
15		14		13		12		11		10		9		8		7		6		5		4		3		2		1		0	
SPI3 RST	SPI2 RST	Reserved				WWD GRST	Reserved				TIM7 RST	TIM6 RST	TIM5 RST	TIM4 RST	TIM3 RST	TIM2 RST															
rw	rw					rw					rw	rw	rw	rw	rw	rw															

Bits 31:30 Reserved, always read as 0.

- Bit 29 **DACRST**: DAC interface reset  
Set and cleared by software.  
0: No effect  
1: Reset DAC interface

- Bit 28 **PWRRST**: Power interface reset  
Set and cleared by software.  
0: No effect  
1: Reset power interface

- Bit 27 **BKPRST**: Backup interface reset  
Set and cleared by software.  
0: No effect  
1: Reset backup interface
- Bit 26 **CAN2RST**: CAN2 reset  
Set and cleared by software.  
0: No effect  
1: Reset CAN2
- Bit 25 **CAN1RST**: CAN1 reset  
Set and cleared by software.  
0: No effect  
1: Reset CAN1
- Bits 24:23 Reserved, always read as 0.
- Bit 22 **I2C2RST**: I2C 2 reset  
Set and cleared by software.  
0: No effect  
1: Reset I2C 2
- Bit 21 **I2C1RST**: I2C1 reset  
Set and cleared by software.  
0: No effect  
1: Reset I2C 1
- Bit 20 **USART5RST**: USART 5 reset  
Set and cleared by software.  
0: No effect  
1: Reset USART 5
- Bit 19 **USART4RST**: USART 4 reset  
Set and cleared by software.  
0: No effect  
1: Reset USART 4
- Bit 18 **USART3RST**: USART 3 reset  
Set and cleared by software.  
0: No effect  
1: Reset USART 3
- Bit 17 **USART2RST**: USART 2 reset  
Set and cleared by software.  
0: No effect  
1: Reset USART 2
- Bits 16 Reserved, always read as 0.
- Bit 15 **SPI3RST**: SPI3 reset  
Set and cleared by software.  
0: No effect  
1: Reset SPI 3
- Bit 14 **SPI2RST**: SPI2 reset  
Set and cleared by software.  
0: No effect  
1: Reset SPI2

Bits 13:12 Reserved, always read as 0.

Bit 11 **WWDGRST**: Window watchdog reset  
Set and cleared by software.  
0: No effect  
1: Reset window watchdog

Bits 10:6 Reserved, always read as 0.

Bit 5 **TIM7RST**: Timer 7 reset  
Set and cleared by software.  
0: No effect  
1: Reset timer 7

Bit 4 **TIM6RST**: Timer 6 reset  
Set and cleared by software.  
0: No effect  
1: Reset timer 6

Bit 3 **TIM5RST**: Timer 5 reset  
Set and cleared by software.  
0: No effect  
1: Reset timer 5

Bit 2 **TIM4RST**: Timer 4 reset  
Set and cleared by software.  
0: No effect  
1: Reset timer 4

Bit 1 **TIM3RST**: Timer 3 reset  
Set and cleared by software.  
0: No effect  
1: Reset timer 3

Bit 0 **TIM2RST**: Timer 2 reset  
Set and cleared by software.  
0: No effect  
1: Reset timer 2

### 7.3.6 AHB Peripheral Clock enable register (RCC\_AHBENR)

Address offset: 0x14

Reset value: 0x0000 0014

Access: no wait state, word, half-word and byte access

Reserved													ETH MACR XEN			
													rw			
31	30	29	28	27	26	25	24	23	22	21	20	19	18	17	16	
15	14	13	12	11	10	9	8	7	6	5	4	3	2	1	0	
ETHM ACTX EN	ETHM ACEN	Res.	OTGF SEN	Reserved						CRCEN	Res.	FLITFE N	Res.	SRAM EN	DMA2 EN	DMA1 EN
rw	rw		rw							rw		rw		rw	rw	rw

Bits 31:17 Reserved, always read as 0.

Bit 16 **ETHMACRXEN**: Ethernet MAC RX clock enable

Set and cleared by software.

0: Ethernet MAC RX clock disabled

1: Ethernet MAC RX clock enabled

*Note: In the RMII mode, if this clock is enabled, the RMII clock of the MAC is also enabled.*

Bit 15 **ETHMACTXEN**: Ethernet MAC TX clock enable

Set and cleared by software.

0: Ethernet MAC TX clock disabled

1: Ethernet MAC TX clock enabled

*Note: In the RMII mode, if this clock is enabled, the RMII clock of the MAC is also enabled.*

Bit 14 **ETHMACEN**: Ethernet MAC clock enable

Set and cleared by software. Selection of PHY interface (MII/RMII) must be done before enabling the MAC clock.

0: Ethernet MAC clock disabled

1: Ethernet MAC clock enabled

Bit 13 Reserved, always read as 0.

Bit 12 **OTGFSEN**: USB OTG FS clock enable

Set and cleared by software.

0: USB OTG FS clock disabled

1: USB OTG FS clock enabled

Bits 11:7 Reserved, always read as 0.

Bit 6 **CRCEN**: CRC clock enable

Set and cleared by software.

0: CRC clock disabled

1: CRC clock enabled

Bit 5 Reserved, always read as 0.

- Bit 4 **FLITFEN**: FLITF clock enable  
 Set and cleared by software to disable/enable FLITF clock during sleep mode.  
 0: FLITF clock disabled during Sleep mode  
 1: FLITF clock enabled during Sleep mode
- Bit 3 Reserved, always read as 0.
- Bit 2 **SRAMEN**: SRAM interface clock enable  
 Set and cleared by software to disable/enable SRAM interface clock during Sleep mode.  
 0: SRAM interface clock disabled during Sleep mode  
 1: SRAM interface clock enabled during Sleep mode
- Bit 1 **DMA2EN**: DMA2 clock enable  
 Set and cleared by software.  
 0: DMA2 clock disabled  
 1: DMA2 clock enabled
- Bit 0 **DMA1EN**: DMA1 clock enable  
 Set and cleared by software.  
 0: DMA1 clock disabled  
 1: DMA1 clock enabled

### 7.3.7 APB2 peripheral clock enable register (RCC\_APB2ENR)

Address: 0x18

Reset value: 0x0000 0000

Access: word, half-word and byte access

No wait states, except if the access occurs while an access to a peripheral in the APB2 domain is on going. In this case, wait states are inserted until the access to APB2 peripheral is finished.

31	30	29	28	27	26	25	24	23	22	21	20	19	18	17	16	
Reserved																
15	14	13	12	11	10	9	8	7	6	5	4	3	2	1	0	
Res.	USAR T1EN	Res.	SPI1 EN	TIM1 EN	ADC2 EN	ADC1 EN	Reserved			IOPE EN	IOPD EN	IOPC EN	IOPB EN	IOPA EN	Res.	AFIO EN
	rw		rw	rw	rw	rw				rw	rw	rw	rw	rw		rw

- Bits 31:15 Reserved, always read as 0.
- Bit 14 **USART1EN**: USART1 clock enable  
 Set and cleared by software.  
 0: USART1 clock disabled  
 1: USART1 clock enabled
- Bit 13 Reserved, always read as 0.
- Bit 12 **SPI1EN**: SPI 1 clock enable  
 Set and cleared by software.  
 0: SPI 1 clock disabled  
 1: SPI 1 clock enabled

- Bit 11 **TIM1EN**: TIM1 Timer clock enable  
Set and cleared by software.  
0: TIM1 timer clock disabled  
1: TIM1 timer clock enabled
- Bit 10 **ADC2EN**: ADC 2 interface clock enable  
Set and cleared by software.  
0: ADC 2 interface clock disabled  
1: ADC 2 interface clock enabled
- Bit 9 **ADC1EN**: ADC 1 interface clock enable  
Set and cleared by software.  
0: ADC 1 interface disabled  
1: ADC 1 interface clock enabled
- Bits 8:7 Reserved, always read as 0.
- Bit 6 **IOPEEN**: I/O port E clock enable  
Set and cleared by software.  
0: I/O port E clock disabled  
1: I/O port E clock enabled
- Bit 5 **IOPDEN**: I/O port D clock enable  
Set and cleared by software.  
0: I/O port D clock disabled  
1: I/O port D clock enabled
- Bit 4 **IOPCEN**: I/O port C clock enable  
Set and cleared by software.  
0: I/O port C clock disabled  
1: I/O port C clock enabled
- Bit 3 **IOPBEN**: I/O port B clock enable  
Set and cleared by software.  
0: I/O port B clock disabled  
1: I/O port B clock enabled
- Bit 2 **IOPAEN**: I/O port A clock enable  
Set and cleared by software.  
0: I/O port A clock disabled  
1: I/O port A clock enabled
- Bit 1 Reserved, always read as 0.
- Bit 0 **AFIOEN**: Alternate function I/O clock enable  
Set and cleared by software.  
0: Alternate Function I/O clock disabled  
1: Alternate Function I/O clock enabled

### 7.3.8 APB1 peripheral clock enable register (RCC\_APB1ENR)

Address: 0x1C

Reset value: 0x0000 0000

Access: word, half-word and byte access

No wait state, except if the access occurs while an access to a peripheral on APB1 domain is on going. In this case, wait states are inserted until this access to APB1 peripheral is finished.

31	30	29	28	27	26	25	24	23	22	21	20	19	18	17	16
Reserved		DAC EN	PWR EN	BKP EN	CAN2 EN	CAN1 EN	Reserved		I2C2 EN	I2C1 EN	UART5 EN	UART4 EN	USART3 EN	USART2 EN	Res.
		rw	rw	rw	rw	rw			rw	rw	rw	rw	rw	rw	
15	14	13	12	11	10	9	8	7	6	5	4	3	2	1	0
SPI3 EN	SPI2 EN	Reserved		WWD GEN	Reserved					TIM7 EN	TIM6 EN	TIM5 EN	TIM4 EN	TIM3 EN	TIM2 EN
rw	rw			rw						rw	rw	rw	rw	rw	rw

Bits 31:30 Reserved, always read as 0.

Bit 29 **DACEN**: DAC interface clock enable  
 Set and cleared by software.  
 0: DAC interface clock disabled  
 1: DAC interface clock enable

Bit 28 **PWREN**: Power interface clock enable  
 Set and cleared by software.  
 0: Power interface clock disabled  
 1: Power interface clock enable

Bit 27 **BKPEN**: Backup interface clock enable  
 Set and cleared by software.  
 0: Backup interface clock disabled  
 1: Backup interface clock enabled

Bit 26 **CAN2EN**: CAN2 clock enable  
 Set and cleared by software.  
 0: CAN2 clock disabled  
 1: CAN2 clock enabled

Bit 25 **CAN1EN**: CAN1 clock enable  
 Set and cleared by software.  
 0: CAN1 clock disabled  
 1: CAN1 clock enabled

Bits 24:23 Reserved, always read as 0.

Bit 22 **I2C2EN**: I2C 2 clock enable  
 Set and cleared by software.  
 0: I2C 2 clock disabled  
 1: I2C 2 clock enabled



- Bit 21 **I2C1EN**: I2C 1 clock enable  
Set and cleared by software.  
0: I2C 1 clock disabled  
1: I2C 1 clock enabled
- Bit 20 **USART5EN**: USART 5 clock enable  
Set and cleared by software.  
0: USART 5 clock disabled  
1: USART 5 clock enabled
- Bit 19 **USART4EN**: USART 4 clock enable  
Set and cleared by software.  
0: USART 4 clock disabled  
1: USART 4 clock enabled
- Bit 18 **USART3EN**: USART 3 clock enable  
Set and cleared by software.  
0: USART 3 clock disabled  
1: USART 3 clock enabled
- Bit 17 **USART2EN**: USART 2 clock enable  
Set and cleared by software.  
0: USART 2 clock disabled  
1: USART 2 clock enabled
- Bits 16 Reserved, always read as 0.
- Bit 15 **SPI3EN**: SPI 3 clock enable  
Set and cleared by software.  
0: SPI 3 clock disabled  
1: SPI 3 clock enabled
- Bit 14 **SPI2EN**: SPI 2 clock enable  
Set and cleared by software.  
0: SPI 2 clock disabled  
1: SPI 2 clock enabled
- Bits 13:12 Reserved, always read as 0.
- Bit 11 **WWDGEN**: Window watchdog clock enable  
Set and cleared by software.  
0: Window watchdog clock disabled  
1: Window watchdog clock enabled
- Bits 10:6 Reserved, always read as 0.
- Bit 5 **TIM7EN**: Timer 7 clock enable  
Set and cleared by software.  
0: Timer 7 clock disabled  
1: Timer 7 clock enabled
- Bit 4 **TIM6EN**: Timer 6 clock enable  
Set and cleared by software.  
0: Timer 6 clock disabled  
1: Timer 6 clock enabled

- Bit 3 **TIM5EN**: Timer 5 clock enable  
Set and cleared by software.  
0: Timer 5 clock disabled  
1: Timer 5 clock enabled
- Bit 2 **TIM4EN**: Timer 4 clock enable  
Set and cleared by software.  
0: Timer 4 clock disabled  
1: Timer 4 clock enabled
- Bit 1 **TIM3EN**: Timer 3 clock enable  
Set and cleared by software.  
0: Timer 3 clock disabled  
1: Timer 3 clock enabled
- Bit 0 **TIM2EN**: Timer 2 clock enable  
Set and cleared by software.  
0: Timer 2 clock disabled  
1: Timer 2 clock enabled

### 7.3.9 Backup domain control register (RCC\_BDCR)

Address: 0x20

Reset value: 0x0000 0000, reset by Backup domain Reset.

Access: 0 ≤ wait state ≤ 3, word, half-word and byte access

Wait states are inserted in the case of successive accesses to this register.

*Note:* **LSEON**, **LSEBYP**, **RTCSEL** and **RTCEN** bits of the **Backup domain control register (RCC\_BDCR)** are in the Backup domain. As a result, after Reset, these bits are write-protected and the **DBP** bit in the **Power control register (PWR\_CR)** has to be set before these can be modified. Refer to [Section 5 on page 73](#) for further information. These bits are only reset after a Backup domain Reset (see [Section 7.1.3: Backup domain reset](#)). Any internal or external Reset will not have any effect on these bits.

	31	30	29	28	27	26	25	24	23	22	21	20	19	18	17	16	
Reserved																BDRST	
																rw	
	15	14	13	12	11	10	9	8	7	6	5	4	3	2	1	0	
RTC EN	Reserved						RTCSEL[1:0]		Reserved						LSE BYP	LSE RDY	LSEON
rw							rw	rw							rw	r	rw

Bits 31:17 Reserved, always read as 0.

- Bit 16 **BDRST**: Backup domain software reset  
Set and cleared by software.  
0: Reset not activated  
1: Resets the entire Backup domain

Bit 15 **RTCEN**: RTC clock enable

Set and cleared by software.

0: RTC clock disabled

1: RTC clock enabled

Bits 14:10 Reserved, always read as 0.

Bits 9:8 **RTCSEL[1:0]**: RTC clock source selection

Set by software to select the clock source for the RTC. Once the RTC clock source has been selected, it cannot be changed anymore unless the Backup domain is reset. The BDRST bit can be used to reset the RTCSEL[1:0] bits.

00: No clock

01: LSE oscillator clock used as RTC clock

10: LSI oscillator clock used as RTC clock

11: HSE oscillator clock divided by 128 used as RTC clock

Bits 7:3 Reserved, always read as 0.

Bit 2 **LSEBYP**: External Low Speed oscillator bypass

Set and cleared by software to bypass oscillator in debug mode. This bit can be written only when the external 32 kHz oscillator is disabled.

0: LSE oscillator not bypassed

1: LSE oscillator bypassed

Bit 1 **LSERDY**: External Low Speed oscillator ready

Set and cleared by hardware to indicate when the external 32 kHz oscillator is stable. After the LSEON bit is cleared, LSERDY goes low after 6 external low speed oscillator clock cycles

0: External 32 kHz oscillator not ready

1: External 32 kHz oscillator ready

Bit 0 **LSEON**: External Low Speed oscillator enable

Set and cleared by software.

0: External 32 kHz oscillator OFF

1: External 32 kHz oscillator ON

### 7.3.10 Control/status register (RCC\_CSR)

Address: 0x24

Reset value: 0x0C00 0000, reset by system Reset, except reset flags by power Reset only.

Access: 0 ≤ wait state ≤ 3, word, half-word and byte access

Wait states are inserted in the case of successive accesses to this register.

31	30	29	28	27	26	25	24	23	22	21	20	19	18	17	16
LPWR RSTF	WWDG RSTF	IWDG RSTF	SFT RSTF	POR RSTF	PIN RSTF	Res.	RMVF	Reserved							
rw	rw	rw	rw	rw	rw		rw								
15	14	13	12	11	10	9	8	7	6	5	4	3	2	1	0
Reserved													LSI RDY	LSION	
													r	rw	

- Bit 31 LPWRRSTF:** Low-power reset flag  
 Set by hardware when a Low-power management reset occurs. It is cleared by writing to the RMVF bit.  
 0: No Low-power management reset occurred  
 1: Low-power management reset occurred  
 For further information on Low-power management reset, refer to [Section : Low-power management reset](#).
- Bit 30 WWDGRSTF:** Window watchdog reset flag  
 Set by hardware when a window watchdog reset occurs. It is cleared by writing to the RMVF bit.  
 0: No window watchdog reset occurred  
 1: Window watchdog reset occurred
- Bit 29 IWDGRSTF:** Independent watchdog reset flag  
 Set by hardware when an independent watchdog reset from V<sub>DD</sub> domain occurs. It is cleared by writing to the RMVF bit.  
 0: No watchdog reset occurred  
 1: Watchdog reset occurred
- Bit 28 SFTRSTF:** Software reset flag  
 Set by hardware when a software reset occurs. It is cleared by writing to the RMVF bit.  
 0: No software reset occurred  
 1: Software reset occurred
- Bit 27 PORRSTF:** POR/PDR reset flag  
 Set by hardware when a POR/PDR reset occurs. It is cleared by writing to the RMVF bit.  
 0: No POR/PDR reset occurred  
 1: POR/PDR reset occurred
- Bit 26 PINRSTF:** PIN reset flag  
 Set by hardware when a reset from the NRST pin occurs. It is cleared by writing to the RMVF bit.  
 0: No reset from NRST pin occurred  
 1: Reset from NRST pin occurred
- Bit 25** Reserved, always read as 0.

Bit 24 **RMVF**: Remove reset flag  
 Set by software to clear the reset flags.  
 0: No effect  
 1: Clear the reset flags

Bits 23:2 Reserved, always read as 0.

Bit 1 **LSIRDY**: Internal low speed oscillator ready  
 Set and cleared by hardware to indicate when the internal RC 40 kHz oscillator is stable.  
 After the LSION bit is cleared, LSIRDY goes low after 3 internal 40 kHz RC oscillator clock cycles.  
 0: Internal RC 40 kHz oscillator not ready  
 1: Internal RC 40 kHz oscillator ready

Bit 0 **LSION**: Internal low speed oscillator enable  
 Set and cleared by software.  
 0: Internal RC 40 kHz oscillator OFF  
 1: Internal RC 40 kHz oscillator ON

### 7.3.11 AHB peripheral clock reset register (RCC\_AHBRSTR)

Address offset: 0x28

Reset value: 0x0000 0000

Access: no wait state, word, half-word and byte access

31	30	29	28	27	26	25	24	23	22	21	20	19	18	17	16
Reserved															
15	14	13	12	11	10	9	8	7	6	5	4	3	2	1	0
Res.	ETHMAC RST	Res.	OTGFS RST	Reserved											
	rw		rw												

Bits 31:15 Reserved, always read as 0.

Bit 14 **ETHMACRST** Ethernet MAC reset  
 Set and cleared by software.  
 0: No effect  
 1: Reset ETHERNET MAC

Bit 13 Reserved, always read as 0.

Bit 12 **OTGFSRST** USB OTG FS reset  
 Set and cleared by software.  
 0: No effect  
 1: Reset USB OTG FS

Bits 11:0 Reserved, always read as 0.

### 7.3.12 Clock configuration register2 (RCC\_CFGR2)

Address offset: 0x2C

Reset value: 0x0000 0000

Access: no wait state, word, half-word and byte access

31	30	29	28	27	26	25	24	23	22	21	20	19	18	17	16
Reserved													I2S3S RC	I2S2S RC	PREDI V1SRC
													rw	rw	rw
15	14	13	12	11	10	9	8	7	6	5	4	3	2	1	0
PLL3MUL[3:0]				PLL2MUL[3:0]				PREDIV2[3:0]				PREDIV1[3:0]			
rw	rw	rw	rw	rw	rw	rw	rw	rw	rw	rw	rw	rw	rw	rw	rw

Bits 31:19 Reserved, always read as 0.

Bit 18 **I2S3SRC**: I2S3 clock source

Set and cleared by software to select I2S3 clock source. This bit must be valid before enabling I2S3 clock.

0: System clock (SYSCLK) selected as I2S3 clock entry

1: PLL3 VCO clock selected as I2S3 clock entry

Bit 17 **I2S2SRC**: I2S2 clock source

Set and cleared by software to select I2S2 clock source. This bit must be valid before enabling I2S2 clock.

0: System clock (SYSCLK) selected as I2S2 clock entry

1: PLL3 VCO clock selected as I2S2 clock entry

Bit 16 **PREDIV1SRC**: PREDIV1 entry clock source

Set and cleared by software to select PREDIV1 clock source. This bit can be written only when PLL is disabled.

0: HSE oscillator clock selected as PREDIV1 clock entry

1: PLL2 selected as PREDIV1 clock entry

Bits 15:12 **PLL3MUL[3:0]**: PLL3 Multiplication Factor

Set and cleared by software to control PLL3 multiplication factor. These bits can be written only when PLL3 is disabled.

00xx: Reserved

010x: Reserved

0110: PLL3 clock entry x 8

0111: PLL3 clock entry x 9

1000: PLL3 clock entry x 10

1001: PLL3 clock entry x 11

1010: PLL3 clock entry x 12

1011: PLL3 clock entry x 13

1100: PLL3 clock entry x 14

1101: Reserved

1110: PLL3 clock entry x 16

1111: PLL3 clock entry x 20

Bits 11:8 **PLL2MUL[3:0]**: PLL2 Multiplication Factor

Set and cleared by software to control PLL2 multiplication factor. These bits can be written only when PLL2 is disabled.

00xx: Reserved  
010x: Reserved  
0110: PLL2 clock entry x 8  
0111: PLL2 clock entry x 9  
1000: PLL2 clock entry x 10  
1001: PLL2 clock entry x 11  
1010: PLL2 clock entry x 12  
1011: PLL2 clock entry x 13  
1100: PLL2 clock entry x 14  
1101: Reserved  
1110: PLL2 clock entry x 16  
1111: PLL2 clock entry x 20

Bits 7:4 **PREDIV2[3:0]**: PREDIV2 division factor

Set and cleared by software to select PREDIV2 division factor. These bits can be written only when both PLL2 and PLL3 are disabled.

0000: PREDIV2 input clock not divided  
0001: PREDIV2 input clock divided by 2  
0010: PREDIV2 input clock divided by 3  
0011: PREDIV2 input clock divided by 4  
0100: PREDIV2 input clock divided by 5  
0101: PREDIV2 input clock divided by 6  
0110: PREDIV2 input clock divided by 7  
0111: PREDIV2 input clock divided by 8  
1000: PREDIV2 input clock divided by 9  
1001: PREDIV2 input clock divided by 10  
1010: PREDIV2 input clock divided by 11  
1011: PREDIV2 input clock divided by 12  
1100: PREDIV2 input clock divided by 13  
1101: PREDIV2 input clock divided by 14  
1110: PREDIV2 input clock divided by 15  
1111: PREDIV2 input clock divided by 16

Bits 3:0 **PREDIV1[3:0]**: PREDIV1 division factor

Set and cleared by software to select PREDIV1 division factor. These bits can be written only when PLL is disabled.

Note: Bit(0) is the same as bit(17) in the RCC\_CFGR register, so modifying bit(17) in the RCC\_CFGR register changes Bit(0) accordingly.

- 0000: PREDIV1 input clock not divided
- 0001: PREDIV1 input clock divided by 2
- 0010: PREDIV1 input clock divided by 3
- 0011: PREDIV1 input clock divided by 4
- 0100: PREDIV1 input clock divided by 5
- 0101: PREDIV1 input clock divided by 6
- 0110: PREDIV1 input clock divided by 7
- 0111: PREDIV1 input clock divided by 8
- 1000: PREDIV1 input clock divided by 9
- 1001: PREDIV1 input clock divided by 10
- 1010: PREDIV1 input clock divided by 11
- 1011: PREDIV1 input clock divided by 12
- 1100: PREDIV1 input clock divided by 13
- 1101: PREDIV1 input clock divided by 14
- 1110: PREDIV1 input clock divided by 15
- 1111: PREDIV1 input clock divided by 16

### 7.3.13 RCC register map

The following table gives the RCC register map and the reset values.

Table 17. RCC register map and reset values

Offset	Register	31	30	29	28	27	26	25	24	23	22	21	20	19	18	17	16	15	14	13	12	11	10	9	8	7	6	5	4	3	2	1	0		
0x000	<b>RCC_CR</b>	Reserved	PLL3RDY	PLL3ON	PLL2RDY	PLL2ON	PLL1RDY	PLL1ON	Reserved				CSSON	HSEBYF	HSERDY	HSEON	HSICAL[7:0]						HSITRIM[4:0]				Reserved	HSIRDY	HSION						
	Reset value		0	0	0	0	0	0	0	0	0	0	0	0	0	0	0	x	x	x	x	x	x	x	x	x	1	0	0	0	0	0	1	1	
0x004	<b>RCC_CFGR</b>	Reserved				MCO [3:0]				Reserved	OTGFSPRE	PLLMUL [3:0]			PLLXTPRE	PLLSFC	ADCPRE [1:0]	PPRE2 [2:0]		PPRE1 [2:0]		HPRE[3:0]			SWS [1:0]		SW [1:0]								
	Reset value	0	0	0	0	0	0	0	0	0	0	0	0	0	0	0	0	0	0	0	0	0	0	0	0	0	0	0	0	0	0	0			
0x008	<b>RCC_CIR</b>	Reserved										CSSC	PLL3RDYC	PLL2RDYC	PLL1RDYC	HSERDYC	HSIRDYC	LSERDYC	LSIRDYC	Reserved	PLL3RDYIE	PLL2RDYIE	PLL1RDYIE	HSERDYIE	HSIRDYIE	LSERDYIE	LSIRDYIE	CSSF	PLL3RDYF	PLL2RDYF	PLL1RDYF	HSERDYF	HSIRDYF	LSERDYF	LSIRDYF
	Reset value	0	0	0	0	0	0	0	0	0	0	0	0	0	0	0	0	0	0	0	0	0	0	0	0	0	0	0	0	0	0	0	0		
0x00C	<b>RCC_APB2RSTR</b>	Reserved																Reserved	Reserved	USART1RST	Reserved	SPI1RST	TIM1RST	ADC2RST	ADC1RST	Reserved		IOPERST	IOPDRST	IOPCRST	IOPBRST	IOPARST	Reserved	AFIORST	
	Reset value	0	0	0	0	0	0	0	0	0	0	0	0	0	0	0	0	0	0	0	0	0	0	0	0	0	0	0	0	0	0	0	0		
0x010	<b>RCC_APB1RSTR</b>	Reserved	DACRST	PWRFRST	BKPRST	CAN2RST	CAN1RST	Reserved				I2C2RST	I2C1RST	UART5RST	UART4RST	USART3RST	USART2RST	Reserved	SPI3RST	SPI2RST	Reserved		WWDGGRST	Reserved											
	Reset value	0	0	0	0	0	0	0	0	0	0	0	0	0	0	0	0	0	0	0	0	0	0	0	0	0	0	0	0	0	0	0	0		





Table 17. RCC register map and reset values (continued)

Offset	Register	31	30	29	28	27	26	25	24	23	22	21	20	19	18	17	16	15	14	13	12	11	10	9	8	7	6	5	4	3	2	1	0								
0x014	RCC_AHBENR	Reserved															ETHMACRXEN	ETHMACTXEN	ETHMACEN	Reserved	OTGFSEN	Reserved											CRCEN	Reserved	FLITFEN	Reserved	SRAMEN	DM2AEN	DM1AEN		
	Reset value																0	0	0	0	0												0	0	1	0	1	0	0		
0x018	RCC_APB2ENR	Reserved															Reserved	USART1EN	Reserved	SPI1EN	TIM1EN	ADC2EN	ADC1EN	Reserved											IOPEEN	IOPDEN	IOPCEN	IOPBEN	IOPAEN	Reserved	AFIOEN
	Reset value																0	0	0	0	0	0	0												0	0	0	0	0	0	0
0x01C	RCC_APB1ENR	Reserved	DACEN	PWREN	BKPEN	CAN2EN	CAN1EN	Reserved				I2C2EN	I2C1EN	UART5EN	UART4EN	USART3EN	USART2EN	Reserved	SPI3EN	SPI2EN	Reserved		WWDGEN	Reserved											TIM7EN	TIM6EN	TIM5EN	TIM4EN	TIM3EN	TIM2EN	
	Reset value		0	0	0	0	0					0	0	0	0	0	0	0	0	0	0	0	0	0												0	0	0	0	0	0
0x020	RCC_BDCR	Reserved															BDRST	RTCEN	Reserved				RTC SEL [1:0]		Reserved											LSEBYP	LSERDY	LSEON			
	Reset value																0	0					0 0													0	0	0			
0x024	RCC_CSR	LPWRSTF	WWDGRSTF	IWDGRSTF	SFTRSTF	PORRSTF	PINRSTF	Reserved		RMVF	Reserved																LSIRDY	LSION													
	Reset value	0	0	0	0	1	1			0																	0	0													
0x028	RCC_AHBSTR	Reserved															ETHMACRST	Reserved	OTGFSRST	Reserved																					
	Reset value																0	0	0																						
0x02C	RCC_CFGR2	Reserved															I2S3SRC	I2S2SRC	PREDIV1SRC	PLL3MUL [3:0]			PLL2MUL [3:0]			PREDIV2[3:0]			PREDIV1[3:0]												
	Reset value																0	0	0	0 0 0			0 0 0			0 0 0			0 0 0												

Refer to [Table 1 on page 44](#) for the register boundary addresses.

## 8 General-purpose and alternate-function I/Os (GPIOs and AFIOs)

**Low-density devices** are STM32F101xx, STM32F102xx and STM32F103xx microcontrollers where the Flash memory density ranges between 16 and 32 Kbytes.

**Medium-density devices** are STM32F101xx, STM32F102xx and STM32F103xx microcontrollers where the Flash memory density ranges between 64 and 128 Kbytes.

**High-density devices** are STM32F101xx and STM32F103xx microcontrollers where the Flash memory density ranges between 256 and 512 Kbytes.

**XL-density devices** are STM32F101xx and STM32F103xx microcontrollers where the Flash memory density ranges between 768 Kbytes and 1 Mbyte.

**Connectivity line devices** are STM32F105xx and STM32F107xx microcontrollers.

This section applies to the whole STM32F10xxx family, unless otherwise specified.

### 8.1 GPIO functional description

Each of the general-purpose I/O ports has two 32-bit configuration registers (GPIOx\_CRL, GPIOx\_CRH), two 32-bit data registers (GPIOx\_IDR, GPIOx\_ODR), a 32-bit set/reset register (GPIOx\_BSRR), a 16-bit reset register (GPIOx\_BRR) and a 32-bit locking register (GPIOx\_LCKR).

Subject to the specific hardware characteristics of each I/O port listed in the *datasheet*, each port bit of the General Purpose IO (GPIO) Ports, can be individually configured by software in several modes:

- Input floating
- Input pull-up
- Input-pull-down
- Analog
- Output open-drain
- Output push-pull
- Alternate function push-pull
- Alternate function open-drain

Each I/O port bit is freely programmable, however the I/O port registers have to be accessed as 32-bit words (half-word or byte accesses are not allowed). The purpose of the GPIOx\_BSRR and GPIOx\_BRR registers is to allow atomic read/modify accesses to any of the GPIO registers. This way, there is no risk that an IRQ occurs between the read and the modify access.

*Figure 13* shows the basic structure of an I/O Port bit.

Figure 13. Basic structure of a standard I/O port bit

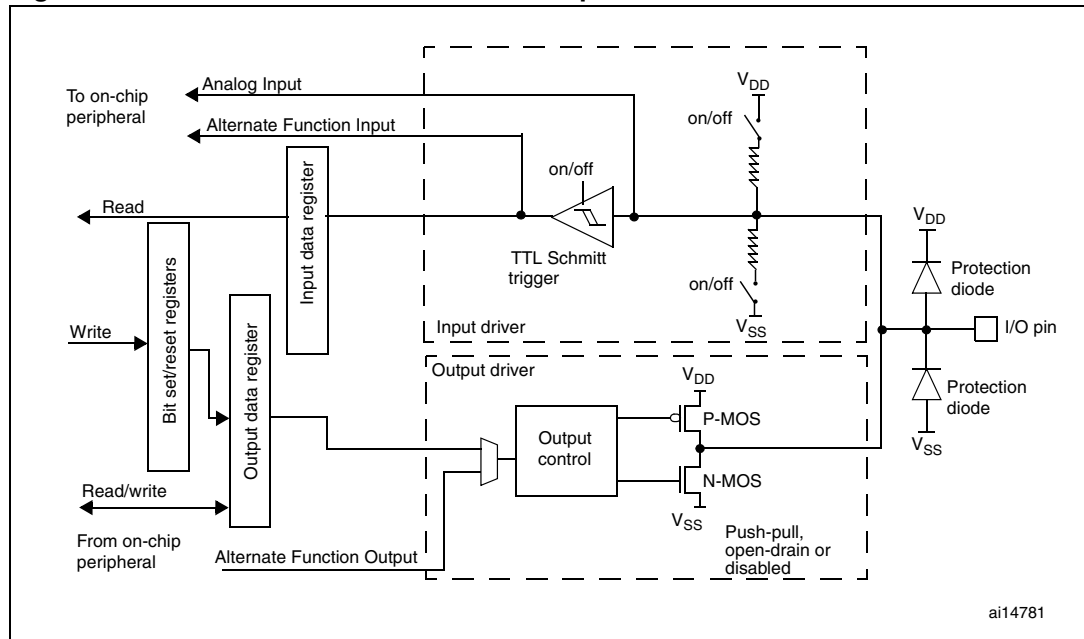
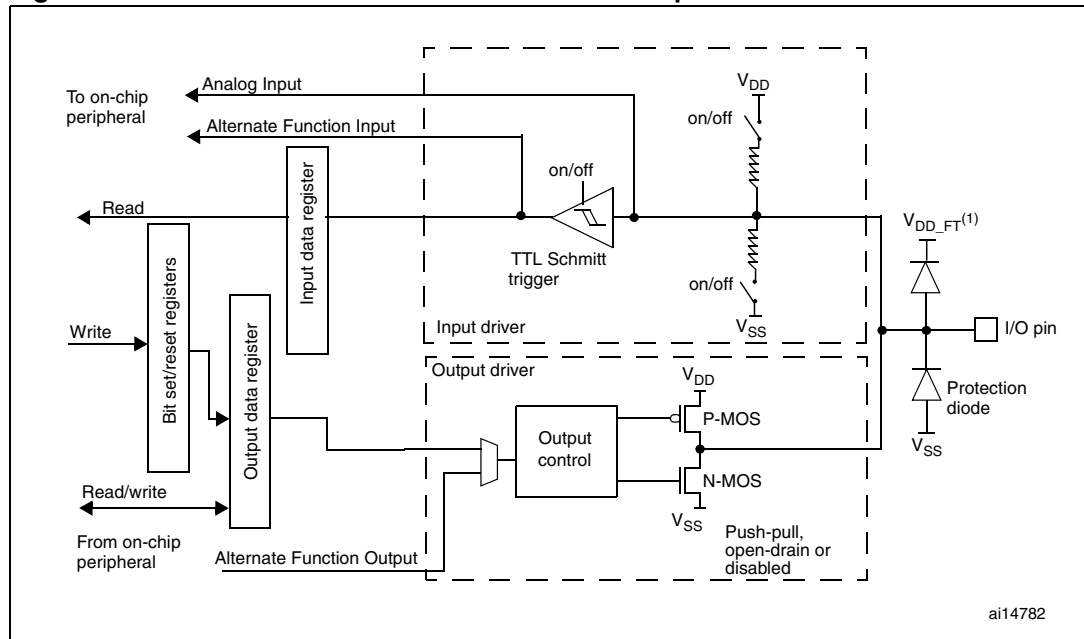


Figure 14. Basic structure of a five-volt tolerant I/O port bit



1.  $V_{DD\_FT}$  is a potential specific to five-volt tolerant I/Os and different from  $V_{DD}$ .

**Table 18. Port bit configuration table**

Configuration mode		CNF1	CNF0	MODE1	MODE0	PxODR register
General purpose output	Push-pull	0	0	01 10 11 see <a href="#">Table 19</a>	00	0 or 1
	Open-drain		1			0 or 1
Alternate Function output	Push-pull	1	0			don't care
	Open-drain		1			don't care
Input	Analog	0	0	don't care		
	Input floating		1	don't care		
	Input pull-down	1	0	0		
	Input pull-up			1		

**Table 19. Output MODE bits**

MODE[1:0]	Meaning
00	Reserved
01	Max. output speed 10 MHz
10	Max. output speed 2 MHz
11	Max. output speed 50 MHz

### 8.1.1 General-purpose I/O (GPIO)

During and just after reset, the alternate functions are not active and the I/O ports are configured in Input Floating mode (CNF<sub>x</sub>[1:0]=01b, MODEx[1:0]=00b).

The JTAG pins are in input PU/PD after reset:

- PA15: JTDI in PU
- PA14: JTCK in PD
- PA13: JTMS in PU
- PB4: NJTRST in PU

When configured as output, the value written to the Output Data register (GPIO<sub>x</sub>\_ODR) is output on the I/O pin. It is possible to use the output driver in Push-Pull mode or Open-Drain mode (only the N-MOS is activated when outputting 0).

The Input Data register (GPIO<sub>x</sub>\_IDR) captures the data present on the I/O pin at every APB2 clock cycle.

All GPIO pins have an internal weak pull-up and weak pull-down which can be activated or not when configured as input.

### 8.1.2 Atomic bit set or reset

There is no need for the software to disable interrupts when programming the GPIO<sub>x</sub>\_ODR at bit level: it is possible to modify only one or several bits in a single atomic APB2 write access. This is achieved by programming to '1' the Bit Set/Reset Register (GPIO<sub>x</sub>\_BSRR,

or for reset only GPIOx\_BRR) to select the bits you want to modify. The unselected bits will not be modified.

### 8.1.3 External interrupt/wakeup lines

All ports have external interrupt capability. To use external interrupt lines, the port must be configured in input mode. For more information on external interrupts, refer to:

- [Section 9.2: External interrupt/event controller \(EXTI\) on page 189](#) and
- [Section 9.2.3: Wakeup event management on page 190](#)

### 8.1.4 Alternate functions (AF)

It is necessary to program the Port Bit Configuration Register before using a default alternate function.

- For alternate function inputs, the port must be configured in Input mode (floating, pull-up or pull-down) and the input pin must be driven externally.

*Note: It is also possible to emulate the AFI input pin by software by programming the GPIO controller. In this case, the port should be configured in Alternate Function Output mode. And obviously, the corresponding port should not be driven externally as it will be driven by the software using the GPIO controller.*

- For alternate function outputs, the port must be configured in Alternate Function Output mode (Push-Pull or Open-Drain).
- For bidirectional Alternate Functions, the port bit must be configured in Alternate Function Output mode (Push-Pull or Open-Drain). In this case the input driver is configured in input floating mode

If you configure a port bit as Alternate Function Output, this disconnects the output register and connects the pin to the output signal of an on-chip peripheral.

If software configures a GPIO pin as Alternate Function Output, but peripheral is not activated, its output is not specified.

### 8.1.5 Software remapping of I/O alternate functions

To optimize the number of peripheral I/O functions for different device packages, it is possible to remap some alternate functions to some other pins. This is achieved by software, by programming the corresponding registers (refer to [AFIO registers on page 168](#)). In that case, the alternate functions are no longer mapped to their original assignments.

### 8.1.6 GPIO locking mechanism

The locking mechanism allows the IO configuration to be frozen. When the LOCK sequence has been applied on a port bit, it is no longer possible to modify the value of the port bit until the next reset.

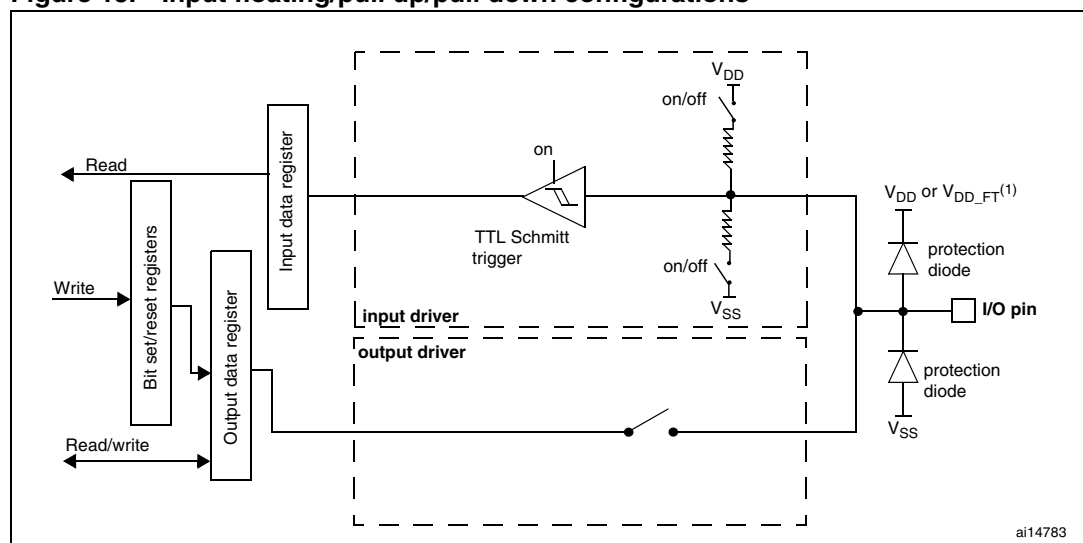
### 8.1.7 Input configuration

When the I/O Port is programmed as Input:

- The Output Buffer is disabled
- The Schmitt Trigger Input is activated
- The weak pull-up and pull-down resistors are activated or not depending on input configuration (pull-up, pull-down or floating):
- The data present on the I/O pin is sampled into the Input Data Register every APB2 clock cycle
- A read access to the Input Data Register obtains the I/O State.

The [Figure 15 on page 150](#) shows the Input Configuration of the I/O Port bit.

**Figure 15. Input floating/pull up/pull down configurations**



1.  $V_{DD\_FT}$  is a potential specific to five-volt tolerant I/Os and different from  $V_{DD}$ .

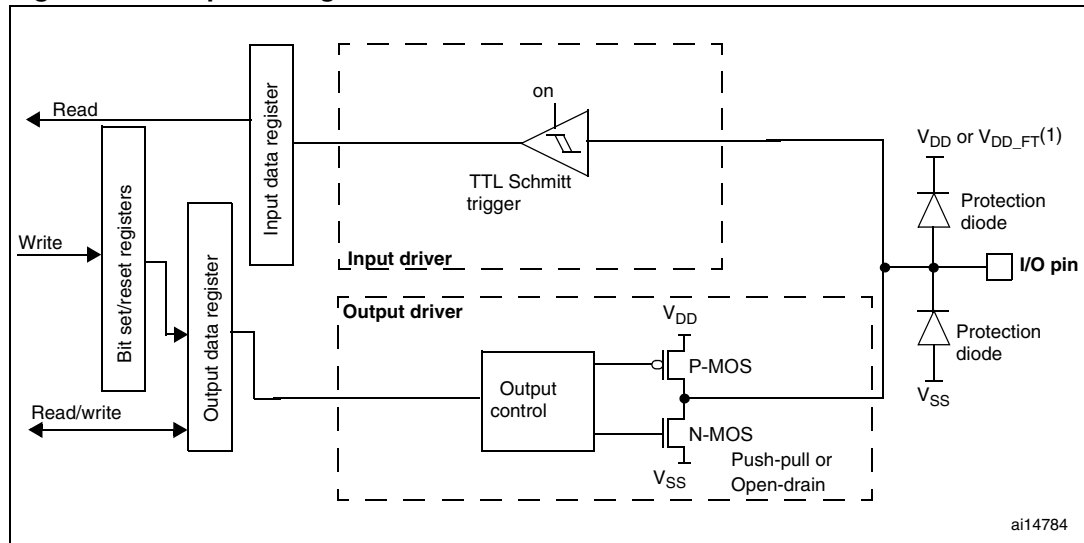
### 8.1.8 Output configuration

When the I/O Port is programmed as Output:

- The Output Buffer is enabled:
  - Open Drain Mode: A “0” in the Output register activates the N-MOS while a “1” in the Output register leaves the port in Hi-Z. (the P-MOS is never activated)
  - Push-Pull Mode: A “0” in the Output register activates the N-MOS while a “1” in the Output register activates the P-MOS.
- The Schmitt Trigger Input is activated.
- The weak pull-up and pull-down resistors are disabled.
- The data present on the I/O pin is sampled into the Input Data Register every APB2 clock cycle
- A read access to the Input Data Register gets the I/O state in open drain mode
- A read access to the Output Data register gets the last written value in Push-Pull mode

The [Figure 16 on page 151](#) shows the Output configuration of the I/O Port bit.

Figure 16. Output configuration



1.  $V_{DD\_FT}$  is a potential specific to five-volt tolerant I/Os and different from  $V_{DD}$ .

### 8.1.9 Alternate function configuration

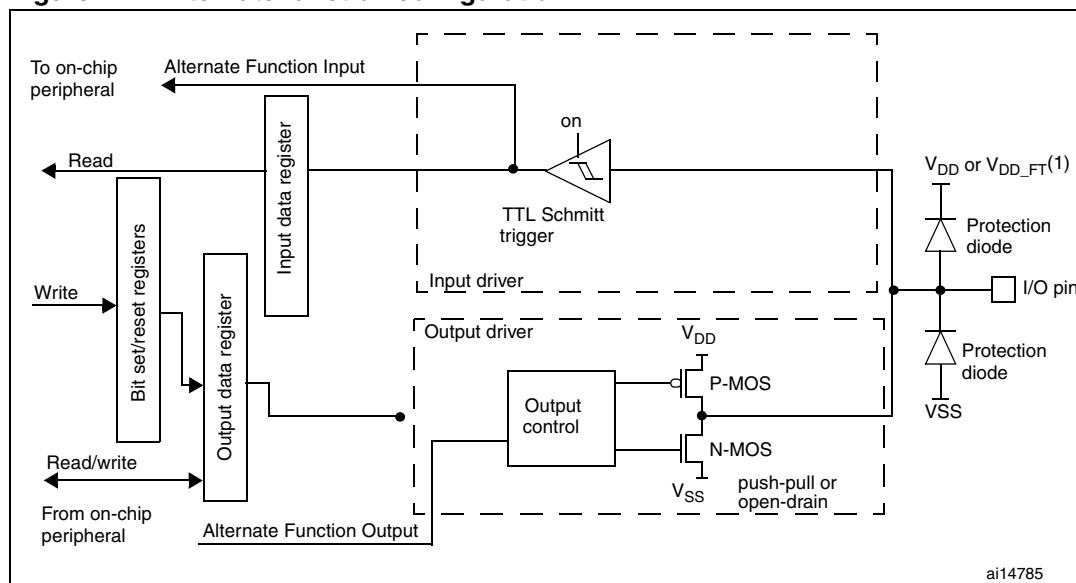
When the I/O Port is programmed as Alternate Function:

- The Output Buffer is turned on in Open Drain or Push-Pull configuration
- The Output Buffer is driven by the signal coming from the peripheral (alternate function out)
- The Schmitt Trigger Input is activated
- The weak pull-up and pull-down resistors are disabled.
- The data present on the I/O pin is sampled into the Input Data Register every APB2 clock cycle
- A read access to the Input Data Register gets the I/O state in open drain mode
- A read access to the Output Data register gets the last written value in Push-Pull mode

The [Figure 17 on page 152](#) shows the Alternate Function Configuration of the I/O Port bit. Also, refer to [Section 8.4: AFIO registers on page 168](#) for further information.

A set of Alternate Function I/O registers allow you to remap some alternate functions to different pins. Refer to

Figure 17. Alternate function configuration



1.  $V_{DD\_FT}$  is a potential specific to five-volt tolerant I/Os and different from  $V_{DD}$ .

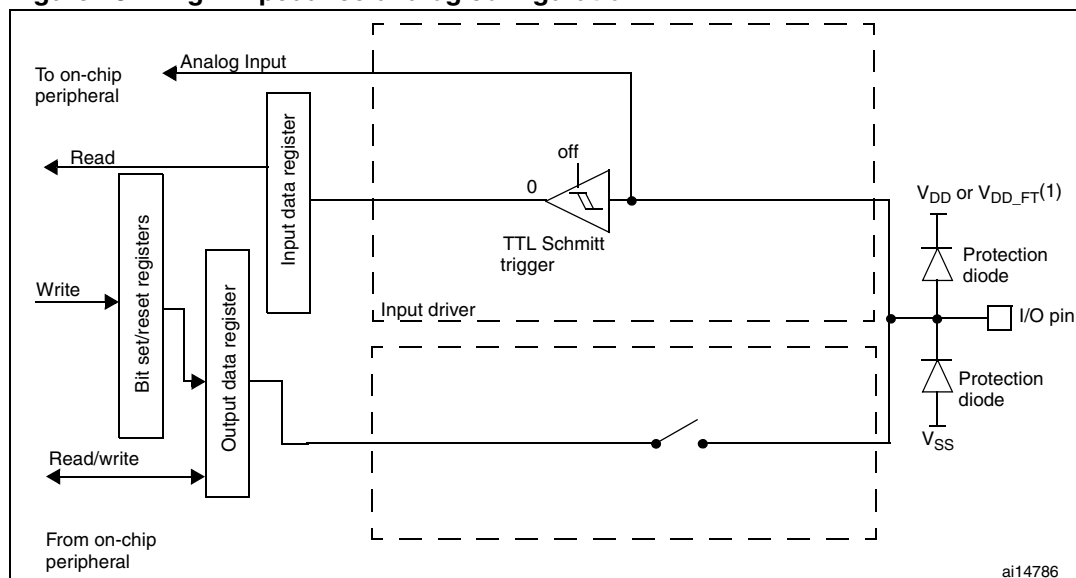
### 8.1.10 Analog configuration

When the I/O Port is programmed as Analog configuration:

- The Output Buffer is disabled.
- The Schmitt Trigger Input is de-activated providing zero consumption for every analog value of the I/O pin. The output of the Schmitt Trigger is forced to a constant value (0).
- The weak pull-up and pull-down resistors are disabled.
- Read access to the Input Data Register gets the value “0”.

The [Figure 18 on page 152](#) shows the high impedance-analog configuration of the I/O Port bit.

Figure 18. High impedance-analog configuration





### 8.1.11 Peripherals' GPIO configurations

Table 20 to Table 31 give the GPIO configurations of the device peripherals.

**Table 20. Advanced timers TIM1/TIM8**

TIM1/8 pinout	configuration	GPIO configuration
TIM1/8_CHx	Input capture channel x	Input floating
	Output compare channel x	Alternate function push-pull
TIM1/8_CHxN	Complementary output channel x	Alternate function push-pull
TIM1/8_BKIN	Break input	Input floating
TIM1/8_ETR	External trigger timer input	Input floating

**Table 21. General-purpose timers TIM2/3/4/5**

TIM2/3/4/5 pinout	Configuration	GPIO configuration
TIM2/3/4/5_CHx	Input capture channel x	Input floating
	Output compare channel x	Alternate function push-pull
TIM2/3/4/5_ETR	External trigger timer input	Input floating

**Table 22. USARTs**

USART pinout	Configuration	GPIO configuration
USARTx_TX	Full duplex	Alternate function push-pull
	Half duplex synchronous mode	Alternate function push-pull
USARTx_RX	Full duplex	Input floating / Input pull-up
	Half duplex synchronous mode	Not used. Can be used as a general IO
USARTx_CK	Synchronous mode	Alternate function push-pull
USARTx_RTS	Hardware flow control	Alternate function push-pull
USARTx_CTS	Hardware flow control	Input floating/ Input pull-up

**Table 23. SPI**

SPI pinout	Configuration	GPIO configuration
SPIx_SCK	Master	Alternate function push-pull
	Slave	Input floating
SPIx_MOSI	Full duplex / Master	Alternate function push-pull
	Full duplex / slave	Input floating / Input pull-up
	Simplex bidirectional data wire / Master	Alternate function push-pull
	Simplex bidirectional data wire/ Slave	Not used. Can be used as a GPIO

**Table 23. SPI (continued)**

SPI pinout	Configuration	GPIO configuration
SPIx_MISO	Full duplex / Master	Input floating / Input pull-up
	Full Duplex / slave	Alternate function push-pull
	Simplex bidirectional data wire / Master	Not used. Can be used as a GPIO
	Simplex bidirectional data wire/ Slave	Alternate function push-pull
SPIx_NSS	Hardware Master /Slave	Input floating/ Input pull-up / Input pull-down
	Hardware Master/ NSS output enabled	Alternate function push-pull
	Software	Not used. Can be used as a GPIO

**Table 24. I2S**

I2S pinout	Configuration	GPIO configuration
I2Sx_WS	Master	Alternate function push-pull
	Slave	Input floating
I2Sx_CK	Master	Alternate function push-pull
	Slave	Input floating
I2Sx_SD	Transmitter	Alternate function push-pull
	Receiver	Input floating/ Input pull-up/ Input pull-down
I2Sx_MCK	Master	Alternate function push-pull
	Slave	Not used. Can be used as a GPIO

**Table 25. I2C**

I2C pinout	Configuration	GPIO configuration
I2Cx_SCL	I2C clock	Alternate function open drain
I2Cx_SDA	I2C Data I/O	Alternate function open drain

**Table 26. BxCAN**

BxCAN pinout	GPIO configuration
CAN_TX (Transmit data line)	Alternate function push-pull
CAN_RX (Receive data line)	Input floating / Input pull-up

**Table 27. USB<sup>(1)</sup>**

USB pinout	GPIO configuration
USB_DM / USB_DP	As soon as the USB is enabled, these pins are connected to the USB internal transceiver automatically.

1. This table applies to low-, medium-, high and XL-density devices only.

**Table 28. OTG\_FS pin configuration<sup>(1)</sup>**

OTG_FS pinout	Configuration	GPIO configuration
OTG_FS_SOF	Host	AF push-pull, if used
	Device	AF push-pull, if used
	OTG	AF push-pull, if used
OTG_FS_VBUS <sup>(2)</sup>	Host	Input floating
	Device	Input floating
	OTG	Input floating
OTG_FS_ID	Host	No need if the Force host mode is selected by software (FHMOD set in the OTG_FS_GUSBCFG register)
	Device	No need if the Force device mode is selected by software (FDMOD set in the OTG_FS_GUSBCFG register)
	OTG	Input pull-up
OTG_FS_DM	Host	Controlled automatically by the USB power-down
	Device	Controlled automatically by the USB power-down
	OTG	Controlled automatically by the USB power-down
OTG_FS_DP	Host	Controlled automatically by the USB power-down
	Device	Controlled automatically by the USB power-down
	OTG	Controlled automatically by the USB power-down

1. This table applies to connectivity line devices only.
2. For the OTG\_FS\_VBUS pin (PA9) to be used by another shared peripheral or as a general-purpose IO, the PHY Power-down mode has to be active (clear bit 16 in the OTG\_FS\_GCCFG register).

**Table 29. SDIO**

SDIO pinout	GPIO configuration
SDIO_CK	Alternate function push-pull
SDIO_CMD	Alternate function push-pull
SDIO[D7:D0]	Alternate function push-pull

The GPIO configuration of the ADC inputs should be analog.

**Figure 19. ADC / DAC**

ADC/DAC pin	GPIO configuration
ADC/DAC	Analog

**Table 30. FSMC**

FSMC pinout	GPIO configuration
FSMC_A[25:0] FSMC_D[15:0]	Alternate function push-pull
FSMC_CK	Alternate function push-pull
FSMC_NOE FSMC_NWE	Alternate function push-pull
FSMC_NE[4:1] FSMC_NCE[3:2] FSMC_NCE4_1 FSMC_NCE4_2	Alternate function push-pull
FSMC_NWAIT FSMC_CD	Input floating/ Input pull-up
FSMC_NIOS16, FSMC_INTR FSMC_INT[3:2]	Input floating
FSMC_NL FSMC_NBL[1:0]	Alternate function push-pull
FSMC_NIORD, FSMC_NIOWR FSMC_NREG	Alternate function push-pull

**Table 31. Other IOs**

Pins	Alternate function	GPIO configuration
TAMPER-RTC pin	RTC output	Forced by hardware when configuring the BKP_CR and BKP_RTCCR registers
	Tamper event input	
MCO	Clock output	Alternate function push-pull
EXTI input lines	External input interrupts	Input floating / input pull-up / input pull-down

## 8.2 GPIO registers

Refer to [Section 1.1 on page 40](#) for a list of abbreviations used in register descriptions.

The peripheral registers have to be accessed by words (32-bit).

### 8.2.1 Port configuration register low (GPIOx\_CRL) (x=A..G)

Address offset: 0x00

Reset value: 0x4444 4444

31	30	29	28	27	26	25	24	23	22	21	20	19	18	17	16
CNF7[1:0]		MODE7[1:0]		CNF6[1:0]		MODE6[1:0]		CNF5[1:0]		MODE5[1:0]		CNF4[1:0]		MODE4[1:0]	
rw	rw	rw	rw	rw	rw	rw	rw	rw	rw	rw	rw	rw	rw	rw	rw
15	14	13	12	11	10	9	8	7	6	5	4	3	2	1	0
CNF3[1:0]		MODE3[1:0]		CNF2[1:0]		MODE2[1:0]		CNF1[1:0]		MODE1[1:0]		CNF0[1:0]		MODE0[1:0]	
rw	rw	rw	rw	rw	rw	rw	rw	rw	rw	rw	rw	rw	rw	rw	rw

Bits 31:30, 27:26, 23:22, 19:18, 15:14, 11:10, 7:6, 3:2 **CNFy[1:0]**: Port x configuration bits (y= 0 .. 7)  
 These bits are written by software to configure the corresponding I/O port.  
 Refer to [Table 18: Port bit configuration table on page 148](#).

**In input mode (MODE[1:0]=00):**

- 00: Analog mode
- 01: Floating input (reset state)
- 10: Input with pull-up / pull-down
- 11: Reserved

**In output mode (MODE[1:0] > 00):**

- 00: General purpose output push-pull
- 01: General purpose output Open-drain
- 10: Alternate function output Push-pull
- 11: Alternate function output Open-drain

Bits 29:28, 25:24, 21:20, 17:16, 13:12, 9:8, 5:4, 1:0 **MODEy[1:0]**: Port x mode bits (y= 0 .. 7)  
 These bits are written by software to configure the corresponding I/O port.  
 Refer to [Table 18: Port bit configuration table on page 148](#).

- 00: Input mode (reset state)
- 01: Output mode, max speed 10 MHz.
- 10: Output mode, max speed 2 MHz.
- 11: Output mode, max speed 50 MHz.

### 8.2.2 Port configuration register high (GPIOx\_CRH) (x=A..G)

Address offset: 0x04

Reset value: 0x4444 4444

31	30	29	28	27	26	25	24	23	22	21	20	19	18	17	16
CNF15[1:0]		MODE15[1:0]		CNF14[1:0]		MODE14[1:0]		CNF13[1:0]		MODE13[1:0]		CNF12[1:0]		MODE12[1:0]	
rw	rw	rw	rw	rw	rw	rw	rw	rw	rw	rw	rw	rw	rw	rw	rw
15	14	13	12	11	10	9	8	7	6	5	4	3	2	1	0
CNF11[1:0]		MODE11[1:0]		CNF10[1:0]		MODE10[1:0]		CNF9[1:0]		MODE9[1:0]		CNF8[1:0]		MODE8[1:0]	
rw	rw	rw	rw	rw	rw	rw	rw	rw	rw	rw	rw	rw	rw	rw	rw

Bits 31:30, 27:26, 23:22, 19:18, 15:14, 11:10, 7:6, 3:2 **CNFy[1:0]**: Port x configuration bits (y= 8 .. 15)  
 These bits are written by software to configure the corresponding I/O port.  
 Refer to [Table 18: Port bit configuration table on page 148](#).

- In input mode (MODE[1:0]=00):**  
 00: Analog mode  
 01: Floating input (reset state)  
 10: Input with pull-up / pull-down  
 11: Reserved
- In output mode (MODE[1:0] > 00):**  
 00: General purpose output push-pull  
 01: General purpose output Open-drain  
 10: Alternate function output Push-pull  
 11: Alternate function output Open-drain

Bits 29:28, 25:24, 21:20, 17:16, 13:12, 9:8, 5:4, 1:0 **MODEy[1:0]**: Port x mode bits (y= 8 .. 15)  
 These bits are written by software to configure the corresponding I/O port.  
 Refer to [Table 18: Port bit configuration table on page 148](#).

- 00: Input mode (reset state)  
 01: Output mode, max speed 10 MHz.  
 10: Output mode, max speed 2 MHz.  
 11: Output mode, max speed 50 MHz.

### 8.2.3 Port input data register (GPIOx\_IDR) (x=A..G)

Address offset: 0x08h

Reset value: 0x0000 XXXX

31	30	29	28	27	26	25	24	23	22	21	20	19	18	17	16
Reserved															
15	14	13	12	11	10	9	8	7	6	5	4	3	2	1	0
IDR15	IDR14	IDR13	IDR12	IDR11	IDR10	IDR9	IDR8	IDR7	IDR6	IDR5	IDR4	IDR3	IDR2	IDR1	IDR0
r	r	r	r	r	r	r	r	r	r	r	r	r	r	r	r

Bits 31:16 Reserved, always read as 0.

Bits 15:0 **IDRy[15:0]**: Port input data (y= 0 .. 15)  
 These bits are read only and can be accessed in Word mode only. They contain the input value of the corresponding I/O port.

### 8.2.4 Port output data register (GPIOx\_ODR) (x=A..G)

Address offset: 0x0C

Reset value: 0x0000 0000

31	30	29	28	27	26	25	24	23	22	21	20	19	18	17	16
Reserved															
15	14	13	12	11	10	9	8	7	6	5	4	3	2	1	0
ODR15	ODR14	ODR13	ODR12	ODR11	ODR10	ODR9	ODR8	ODR7	ODR6	ODR5	ODR4	ODR3	ODR2	ODR1	ODR0
r/w	r/w	r/w	r/w	r/w	r/w	r/w	r/w	r/w	r/w	r/w	r/w	r/w	r/w	r/w	r/w

Bits 31:16 Reserved, always read as 0.

Bits 15:0 **ODRy[15:0]**: Port output data (y= 0 .. 15)

These bits can be read and written by software and can be accessed in Word mode only.

*Note: For atomic bit set/reset, the ODR bits can be individually set and cleared by writing to the GPIOx\_BSRR register (x = A .. G).*

### 8.2.5 Port bit set/reset register (GPIOx\_BSRR) (x=A..G)

Address offset: 0x10

Reset value: 0x0000 0000

31	30	29	28	27	26	25	24	23	22	21	20	19	18	17	16
BR15	BR14	BR13	BR12	BR11	BR10	BR9	BR8	BR7	BR6	BR5	BR4	BR3	BR2	BR1	BR0
w	w	w	w	w	w	w	w	w	w	w	w	w	w	w	w
15	14	13	12	11	10	9	8	7	6	5	4	3	2	1	0
BS15	BS14	BS13	BS12	BS11	BS10	BS9	BS8	BS7	BS6	BS5	BS4	BS3	BS2	BS1	BS0
w	w	w	w	w	w	w	w	w	w	w	w	w	w	w	w

Bits 31:16 **BRy**: Port x Reset bit y (y= 0 .. 15)

These bits are write-only and can be accessed in Word mode only.

0: No action on the corresponding ODRx bit

1: Reset the corresponding ODRx bit

*Note: If both BSx and BRx are set, BSx has priority.*

Bits 15:0 **BSy**: Port x Set bit y (y= 0 .. 15)

These bits are write-only and can be accessed in Word mode only.

0: No action on the corresponding ODRx bit

1: Set the corresponding ODRx bit

### 8.2.6 Port bit reset register (GPIOx\_BRR) (x=A..G)

Address offset: 0x14

Reset value: 0x0000 0000

31	30	29	28	27	26	25	24	23	22	21	20	19	18	17	16
Reserved															
15	14	13	12	11	10	9	8	7	6	5	4	3	2	1	0
BR15	BR14	BR13	BR12	BR11	BR10	BR9	BR8	BR7	BR6	BR5	BR4	BR3	BR2	BR1	BR0
w	w	w	w	w	w	w	w	w	w	w	w	w	w	w	w

Bits 31:16 Reserved

Bits 15:0 **BRy**: Port x Reset bit y (y= 0 .. 15)

These bits are write-only and can be accessed in Word mode only.

0: No action on the corresponding ODRx bit

1: Reset the corresponding ODRx bit

### 8.2.7 Port configuration lock register (GPIOx\_LCKR) (x=A..G)

This register is used to lock the configuration of the port bits when a correct write sequence is applied to bit 16 (LCKK). The value of bits [15:0] is used to lock the configuration of the GPIO. During the write sequence, the value of LCKR[15:0] must not change. When the LOCK sequence has been applied on a port bit it is no longer possible to modify the value of the port bit until the next reset.

Each lock bit freezes the corresponding 4 bits of the control register (CRL, CRH).

Address offset: 0x18

Reset value: 0x0000 0000

31	30	29	28	27	26	25	24	23	22	21	20	19	18	17	16
Reserved															LCKK
															rw
15	14	13	12	11	10	9	8	7	6	5	4	3	2	1	0
LCK15	LCK14	LCK13	LCK12	LCK11	LCK10	LCK9	LCK8	LCK7	LCK6	LCK5	LCK4	LCK3	LCK2	LCK1	LCK0
rw	rw	rw	rw	rw	rw	rw	rw	rw	rw	rw	rw	rw	rw	rw	rw

Bits 31:17 Reserved



Bit 16 **LCKK[16]**: Lock key

This bit can be read anytime. It can only be modified using the Lock Key Writing Sequence.  
0: Port configuration lock key not active  
1: Port configuration lock key active. GPIOx\_LCKR register is locked until an MCU reset occurs.

**LOCK key writing sequence:**

Write 1

Write 0

Write 1

Read 0

Read 1 (this read is optional but confirms that the lock is active)

*Note:* During the LOCK Key Writing sequence, the value of LCK[15:0] must not change.

Any error in the lock sequence will abort the lock.

Bits 15:0 **LCKy**: Port x Lock bit y (y= 0 .. 15)

These bits are read write but can only be written when the LCKK bit is 0.

0: Port configuration not locked

1: Port configuration locked.

## 8.3 Alternate function I/O and debug configuration (AFIO)

To optimize the number of peripherals available for the 64-pin or the 100-pin or the 144-pin package, it is possible to remap some alternate functions to some other pins. This is achieved by software, by programming the [AF remap and debug I/O configuration register \(AFIO\\_MAPR\)](#) on page 170. In this case, the alternate functions are no longer mapped to their original assignments.

### 8.3.1 Using OSC32\_IN/OSC32\_OUT pins as GPIO ports PC14/PC15

The LSE oscillator pins OSC32\_IN and OSC32\_OUT can be used as general-purpose I/O PC14 and PC15, respectively, when the LSE oscillator is off. The LSE has priority over the GP I/Os function.

- Note:*
- 1 The PC14/PC15 GPIO functionality is lost when the 1.8 V domain is powered off (by entering standby mode) or when the backup domain is supplied by V<sub>BAT</sub> (V<sub>DD</sub> no more supplied). In this case the I/Os are set in analog mode.
  - 2 Refer to the note on IO usage restrictions in [Section 4.1.2 on page 61](#).

### 8.3.2 Using OSC\_IN/OSC\_OUT pins as GPIO ports PD0/PD1

The HSE oscillator pins OSC\_IN/OSC\_OUT can be used as general-purpose I/O PD0/PD1 by programming the PD01\_REMAP bit in the [AF remap and debug I/O configuration register \(AFIO\\_MAPR\)](#).

This remap is available only on 36-, 48- and 64-pin packages (PD0 and PD1 are available on 100-pin and 144-pin packages, no need for remapping).

- Note:* The external interrupt/event function is not remapped. PD0 and PD1 cannot be used for external interrupt/event generation on 36-, 48- and 64-pin packages.

### 8.3.3 CAN1 alternate function remapping

The CAN signals can be mapped on Port A, Port B or Port D as shown in [Table 32](#). For port D, remapping is not possible in devices delivered in 36-, 48- and 64-pin packages.

**Table 32. CAN1 alternate function remapping**

Alternate function <sup>(1)</sup>	CAN_REMAP[1:0] = "00"	CAN_REMAP[1:0] = "10" <sup>(2)</sup>	CAN_REMAP[1:0] = "11" <sup>(3)</sup>
CAN1_RX or CAN_RX	PA11	PB8	PD0
CAN1_TX or CAN_TX	PA12	PB9	PD1

1. CAN1\_RX and CAN1\_TX in connectivity line devices; CAN\_RX and CAN\_TX in other devices with a single CAN interface.
2. Remap not available on 36-pin package
3. This remapping is available only on 100-pin and 144-pin packages, when PD0 and PD1 are not remapped on OSC-IN and OSC-OUT.

### 8.3.4 CAN2 alternate function remapping

CAN2 is available in connectivity line devices. The external signal can be remapped as shown in [Chapter Table 33](#).

**Table 33. CAN2 alternate function remapping**

Alternate function	CAN2_REMAP = "0"	CAN2_REMAP = "1"
CAN2_RX	PB12	PB5
CAN2_TX	PB13	PB6

### 8.3.5 JTAG/SWD alternate function remapping

The debug interface signals are mapped on the GPIO ports as shown in [Table 34](#).

**Table 34. Debug interface signals**

Alternate function	GPIO port
JTMS / SWDIO	PA13
JTCK / SWCLK	PA14
JTDI	PA15
JTDO / TRACESWO	PB3
NJTRST	PB4
TRACECK	PE2
TRACED0	PE3
TRACED1	PE4
TRACED2	PE5
TRACED3	PE6

To optimize the number of free GPIOs during debugging, this mapping can be configured in different ways by programming the SWJ\_CFG[1:0] bits in the [AF remap and debug I/O configuration register \(AFIO\\_MAPR\)](#). Refer to [Table 35](#)

**Table 35. Debug port mapping**

SWJ_CFG [2:0]	Available debug ports	SWJ I/O pin assigned				
		PA13 / JTMS/ SWDIO	PA14 / JTCK/S WCLK	PA15 / JTDI	PB3 /JTDO/ TRACE SWO	PB4/ NJTRST
000	Full SWJ (JTAG-DP + SW-DP) (Reset state)	X	X	X	X	X
001	Full SWJ (JTAG-DP + SW-DP) but without NJTRST	X	X	X	x	free
010	JTAG-DP Disabled and SW-DP Enabled	X	X	free	free <sup>(1)</sup>	free
100	JTAG-DP Disabled and SW-DP Disabled	free	free	free	free	free
Other	Forbidden					

1. Released only if not using asynchronous trace.

### 8.3.6 ADC alternate function remapping

Refer to [AF remap and debug I/O configuration register \(AFIO\\_MAPR\)](#).

**Table 36. ADC1 external trigger injected conversion alternate function remapping<sup>(1)</sup>**

Alternate function	ADC1_ETRGINJ_REMAP = 0	ADC1_ETRGINJ_REMAP = 1
ADC1 external trigger injected conversion	ADC1 external trigger injected conversion is connected to EXTI15	ADC1 external trigger injected conversion is connected to TIM8_CH4

1. Remap available only for high-density and XL-density devices.

**Table 37. ADC1 external trigger regular conversion alternate function remapping<sup>(1)</sup>**

Alternate function	ADC1_ETRGREG_REMAP = 0	ADC1_ETRGREG_REMAP = 1
ADC1 external trigger regular conversion	ADC1 external trigger regular conversion is connected to EXTI11	ADC1 external trigger regular conversion is connected to TIM8_TRGO

1. Remap available only for high-density and XL-density devices.

**Table 38. ADC2 external trigger injected conversion alternate function remapping<sup>(1)</sup>**

Alternate function	ADC2_ETRGINJ_REMAP = 0	ADC2_ETRGINJ_REMAP = 1
ADC2 external trigger injected conversion	ADC2 external trigger injected conversion is connected to EXTI 15	ADC2 external trigger injected conversion is connected to TIM8_CH4

1. Remap available only for high-density and XL-density devices.

**Table 39. ADC2 external trigger regular conversion alternate function remapping<sup>(1)</sup>**

Alternate function	ADC2_ETRGREG_REG = 0	ADC2_ETRGREG_REG = 1
ADC2 external trigger regular conversion	ADC2 external trigger regular conversion is connected to EXTI11	ADC2 external trigger regular conversion is connected to TIM8_TRGO

1. Remap available only for high-density and XL-density devices.

### 8.3.7 Timer alternate function remapping

Timer 4 channels 1 to 4 can be remapped from Port B to Port D. Other timer remapping possibilities are listed in [Table 42](#) to [Table 44](#). Refer to [AF remap and debug I/O configuration register \(AFIO\\_MAPR\)](#).

**Table 40. TIM5 alternate function remapping<sup>(1)</sup>**

Alternate function	TIM5CH4_IEMAP = 0	TIM5CH4_IEMAP = 1
TIM5_CH4	TIM5 Channel4 is connected to PA3	LSI internal clock is connected to TIM5_CH4 input for calibration purpose.

1. Remap available only for high-density, XL-density and connectivity line devices.

**Table 41. TIM4 alternate function remapping**

Alternate function	TIM4_REMAP = 0	TIM4_REMAP = 1 <sup>(1)</sup>
TIM4_CH1	PB6	PD12
TIM4_CH2	PB7	PD13
TIM4_CH3	PB8	PD14
TIM4_CH4	PB9	PD15

1. Remap available only for 100-pin and for 144-pin package.

**Table 42. TIM3 alternate function remapping**

Alternate function	TIM3_REMAP[1:0] = "00" (no remap)	TIM3_REMAP[1:0] = "10" (partial remap)	TIM3_REMAP[1:0] = "11" (full remap) <sup>(1)</sup>
TIM3_CH1	PA6	PB4	PC6
TIM3_CH2	PA7	PB5	PC7
TIM3_CH3	PB0		PC8
TIM3_CH4	PB1		PC9

1. Remap available only for 64-pin, 100-pin and 144-pin packages.

**Table 43. TIM2 alternate function remapping**

Alternate function	TIM2_REMAP[1:0] = "00" (no remap)	TIM2_REMAP[1:0] = "01" (partial remap)	TIM2_REMAP[1:0] = "10" (partial remap) <sup>(1)</sup>	TIM2_REMAP[1:0] = "11" (full remap) <sup>(1)</sup>
TIM2_CH1_ETR <sup>(2)</sup>	PA0	PA15	PA0	PA15
TIM2_CH2	PA1	PB3	PA1	PB3
TIM2_CH3	PA2		PB10	
TIM2_CH4	PA3		PB11	

1. Remap not available on 36-pin package.
2. TIM2\_CH1 and TIM2\_ETR share the same pin but cannot be used at the same time (which is why we have this notation: TIM2\_CH1\_ETR).

**Table 44. TIM1 alternate function remapping**

Alternate functions mapping	TIM1_REMAP[1:0] = "00" (no remap)	TIM1_REMAP[1:0] = "01" (partial remap)	TIM1_REMAP[1:0] = "11" (full remap) <sup>(1)</sup>
TIM1_ETR	PA12		PE7
TIM1_CH1	PA8		PE9
TIM1_CH2	PA9		PE11
TIM1_CH3	PA10		PE13
TIM1_CH4	PA11		PE14
TIM1_BKIN	PB12 <sup>(2)</sup>	PA6	PE15
TIM1_CH1N	PB13	PA7	PE8
TIM1_CH2N	PB14 <sup>(2)</sup>	PB0	PE10
TIM1_CH3N	PB15 <sup>(2)</sup>	PB1	PE12

1. Remap available only for 100-pin and 144-pin packages.
2. Remap not available on 36-pin package.

**Table 45. TIM9 remapping<sup>(1)</sup>**

Alternate function	TIM9_REMAP = 0	TIM9_REMAP = 1
TIM9_CH1	PA2	PE5
TIM9_CH1	PA3	PE6

1. Refer to the AF remap and debug I/O configuration register [Section 8.4.7: AF remap and debug I/O configuration register2 \(AFIO\\_MAPR2\)](#).

**Table 46. TIM10 remapping<sup>(1)</sup>**

Alternate function	TIM10_REMAP = 0	TIM10_REMAP = 1
TIM10_CH1	PB8	PF6

1. Refer to the AF remap and debug I/O configuration register [Section 8.4.7: AF remap and debug I/O configuration register2 \(AFIO\\_MAPR2\)](#).

**Table 47. TIM11 remapping<sup>(1)</sup>**

Alternate function	TIM11_REMAP = 0	TIM11_REMAP = 1
TIM11_CH1	PB9	PF7

1. Refer to the AF remap and debug I/O configuration register [Section 8.4.7: AF remap and debug I/O configuration register2 \(AFIO\\_MAPR2\)](#).

**Table 48. TIM13 remapping<sup>(1)</sup>**

Alternate function	TIM13_REMAP = 0	TIM13_REMAP = 1
TIM13_CH1	PA6	PF8

1. Refer to the AF remap and debug I/O configuration register [Section 8.4.7: AF remap and debug I/O configuration register2 \(AFIO\\_MAPR2\)](#).

**Table 49. TIM14 remapping<sup>(1)</sup>**

Alternate function	TIM14_REMAP = 0	TIM14_REMAP = 1
TIM14_CH1	PA7	PF9

1. Refer to the AF remap and debug I/O configuration register [Section 8.4.7: AF remap and debug I/O configuration register2 \(AFIO\\_MAPR2\)](#).

### 8.3.8 USART alternate function remapping

Refer to [AF remap and debug I/O configuration register \(AFIO\\_MAPR\)](#).

**Table 50. USART3 remapping**

Alternate function	USART3_REMAP[1:0] = "00" (no remap)	USART3_REMAP[1:0] = "01" (partial remap) <sup>(1)</sup>	USART3_REMAP[1:0] = "11" (full remap) <sup>(2)</sup>
USART3_TX	PB10	PC10	PD8
USART3_RX	PB11	PC11	PD9
USART3_CK	PB12	PC12	PD10
USART3_CTS	PB13		PD11
USART3_RTS	PB14		PD12

1. Remap available only for 64-pin, 100-pin and 144-pin packages
2. Remap available only for 100-pin and 144-pin packages.

**Table 51. USART2 remapping**

Alternate functions	USART2_REMAP = 0	USART2_REMAP = 1 <sup>(1)</sup>
USART2_CTS	PA0	PD3
USART2_RTS	PA1	PD4
USART2_TX	PA2	PD5
USART2_RX	PA3	PD6
USART2_CK	PA4	PD7

1. Remap available only for 100-pin and 144-pin packages.

**Table 52. USART1 remapping**

Alternate function	USART1_REMAP = 0	USART1_REMAP = 1
USART1_TX	PA9	PB6
USART1_RX	PA10	PB7

### 8.3.9 I2C1 alternate function remapping

Refer to [AF remap and debug I/O configuration register \(AFIO\\_MAPR\)](#)

**Table 53. I2C1 remapping**

Alternate function	I2C1_REMAP = 0	I2C1_REMAP = 1 <sup>(1)</sup>
I2C1_SCL	PB6	PB8
I2C1_SDA	PB7	PB9

1. Remap not available on 36-pin package.

### 8.3.10 SPI1 alternate function remapping

Refer to [AF remap and debug I/O configuration register \(AFIO\\_MAPR\)](#)

**Table 54. SPI1 remapping**

Alternate function	SPI1_REMAP = 0	SPI1_REMAP = 1
SPI1_NSS	PA4	PA15
SPI1_SCK	PA5	PB3
SPI1_MISO	PA6	PB4
SPI1_MOSI	PA7	PB5

### 8.3.11 SPI3/I2S3 alternate function remapping

Refer to [AF remap and debug I/O configuration register \(AFIO\\_MAPR\)](#). This remap is available only in connectivity line devices.

**Table 55. SPI3/I2S3 remapping**

Alternate function	SPI3_REMAP = 0	SPI3_REMAP = 1
SPI3_NSS / I2S3_WS	PA15	PA4
SPI3_SCK / I2S3_CK	PB3	PC10
SPI3_MISO	PB4	PC11
SPI3_MOSI / I2S3_SD	PB5	PC12

### 8.3.12 Ethernet alternate function remapping

Refer to [AF remap and debug I/O configuration register \(AFIO\\_MAPR\)](#). Ethernet is available only in connectivity line devices.

**Table 56. ETH remapping**

Alternate function	ETH_REMAP = 0	ETH_REMAP = 1
RX_DV-CRS_DV	PA7	PD8
RXD0	PC4	PD9
RXD1	PC5	PD10
RXD2	PB0	PD11
RXD3	PB1	PD12

## 8.4 AFIO registers

Refer to [Section 1.1 on page 40](#) for a list of abbreviations used in register descriptions.

*Note:* To read/write the `AFIO_EVCR`, `AFIO_MAPR` and `AFIO_EXTICRX` registers, the AFIO clock should first be enabled. Refer to [Section 6.3.7: APB2 peripheral clock enable register \(RCC\\_APB2ENR\)](#).

The peripheral registers have to be accessed by words (32-bit).



### 8.4.1 Event control register (AFIO\_EVCR)

Address offset: 0x00

Reset value: 0x0000 0000

31	30	29	28	27	26	25	24	23	22	21	20	19	18	17	16
Reserved															
15	14	13	12	11	10	9	8	7	6	5	4	3	2	1	0
Reserved								EVOE	PORT[2:0]			PIN[3:0]			
								rw	rw	rw	rw	rw	rw	rw	rw

Bits 31:8 Reserved

Bit 7 **EVOE**: Event output enable

Set and cleared by software. When set the EVENTOUT Cortex output is connected to the I/O selected by the PORT[2:0] and PIN[3:0] bits.

Bits 6:4 **PORT[2:0]**: Port selection

Set and cleared by software. Select the port used to output the Cortex EVENTOUT signal.

*Note: The EVENTOUT signal output capability is not extended to ports PF and PG.*

- 000: PA selected
- 001: PB selected
- 010: PC selected
- 011: PD selected
- 100: PE selected

Bits 3:0 **PIN[3:0]**: Pin selection (x = A .. E)

Set and cleared by software. Select the pin used to output the Cortex EVENTOUT signal.

- 0000: Px0 selected
- 0001: Px1 selected
- 0010: Px2 selected
- 0011: Px3 selected
- ...
- 1111: Px15 selected

### 8.4.2 AF remap and debug I/O configuration register (AFIO\_MAPR)

Address offset: 0x04

Reset value: 0x0000 0000

#### Memory map and bit definitions for low-, medium- high- and XL-density devices:

Reserved				SWJ_CFG[2:0]			Reserved				ADC2_ETRGR EG_REMAP	ADC2_ETRGINJ_REMAP	ADC1_ETRREG_REMAP	ADC1_ETRGINJ_REMAP	TIM5CH4_IEMAP
				w	w	w					rw	rw	rw	rw	rw
15	14	13	12	11	10	9	8	7	6	5	4	3	2	1	0
PD01_REMAP	CAN_REMAP [1:0]		TIM4_REMAP	TIM3_REMAP [1:0]		TIM2_REMAP [1:0]		TIM1_REMAP [1:0]		USART3_REMAP[1:0]		USART2_REMAP	USART1_REMAP	I2C1_REMAP	SPI1_REMAP
rw	rw	rw	rw	rw	rw	rw	rw	rw	rw	rw	rw	rw	rw	rw	rw

Bits 31:27 Reserved

Bits 26:24 **SWJ\_CFG[2:0]:** Serial wire JTAG configuration

These bits are write-only (when read, the value is undefined). They are used to configure the SWJ and trace alternate function I/Os. The SWJ (Serial Wire JTAG) supports JTAG or SWD access to the Cortex debug port. The default state after reset is SWJ ON without trace. This allows JTAG or SW mode to be enabled by sending a specific sequence on the JTMS / JTCK pin.

- 000: Full SWJ (JTAG-DP + SW-DP): Reset State
- 001: Full SWJ (JTAG-DP + SW-DP) but without NJTRST
- 010: JTAG-DP Disabled and SW-DP Enabled
- 100: JTAG-DP Disabled and SW-DP Disabled
- Other combinations: no effect

Bits 23:21 Reserved.

Bits 20 **ADC2\_ETRGREG\_REMAP:** ADC 2 external trigger regular conversion remapping

Set and cleared by software. This bit controls the trigger input connected to ADC2 external trigger regular conversion. When this bit is reset, the ADC2 external trigger regular conversion is connected to EXTI11. When this bit is set, the ADC2 external event regular conversion is connected to TIM8\_TRGO.

Bits 19 **ADC2\_ETRGINJ\_REMAP:** ADC 2 external trigger injected conversion remapping

Set and cleared by software. This bit controls the trigger input connected to ADC2 external trigger injected conversion. When this bit is reset, the ADC2 external trigger injected conversion is connected to EXTI15. When this bit is set, the ADC2 external event injected conversion is connected to TIM8\_Channel4.

Bits 18 **ADC1\_ETRGREG\_REMAP:** ADC 1 external trigger regular conversion remapping

Set and cleared by software. This bit controls the trigger input connected to ADC1 External trigger regular conversion. When reset the ADC1 External trigger regular conversion is connected to EXTI11. When set the ADC1 External Event regular conversion is connected to TIM8 TRGO.

- Bits 17 **ADC1\_ETRGINJ\_REMAP**: ADC 1 External trigger injected conversion remapping  
Set and cleared by software. This bit controls the trigger input connected to ADC1 External trigger injected conversion. When reset the ADC1 External trigger injected conversion is connected to EXTI15. When set the ADC1 External Event injected conversion is connected to TIM8 Channel4.
- Bits 16 **TIM5CH4\_IEMAP**: TIM5 channel4 internal remap  
Set and cleared by software. This bit controls the TIM5\_CH4 internal mapping. When reset the timer TIM5\_CH4 is connected to PA3. When set the LSI internal clock is connected to TIM5\_CH4 input for calibration purpose.
- Bit 15 **PD01\_REMAP**: Port D0/Port D1 mapping on OSC\_IN/OSC\_OUT  
This bit is set and cleared by software. It controls the mapping of PD0 and PD1 GPIO functionality. When the HSE oscillator is not used (application running on internal 8 MHz RC) PD0 and PD1 can be mapped on OSC\_IN and OSC\_OUT. This is available only on 36-, 48- and 64-pin packages (PD0 and PD1 are available on 100-pin and 144-pin packages, no need for remapping).  
0: No remapping of PD0 and PD1  
1: PD0 remapped on OSC\_IN, PD1 remapped on OSC\_OUT,
- Bits 14:13 **CAN\_REMAP[1:0]**: CAN alternate function remapping  
These bits are set and cleared by software. They control the mapping of alternate functions CAN\_RX and CAN\_TX in devices with a single CAN interface.  
00: CAN\_RX mapped to PA11, CAN\_TX mapped to PA12  
01: Not used  
10: CAN\_RX mapped to PB8, CAN\_TX mapped to PB9 (not available on 36-pin package)  
11: CAN\_RX mapped to PD0, CAN\_TX mapped to PD1
- Bit 12 **TIM4\_REMAP**: TIM4 remapping  
This bit is set and cleared by software. It controls the mapping of TIM4 channels 1 to 4 onto the GPIO ports.  
0: No remap (TIM4\_CH1/PB6, TIM4\_CH2/PB7, TIM4\_CH3/PB8, TIM4\_CH4/PB9)  
1: Full remap (TIM4\_CH1/PD12, TIM4\_CH2/PD13, TIM4\_CH3/PD14, TIM4\_CH4/PD15)  
*Note: TIM4\_ETR on PE0 is not re-mapped.*
- Bits 11:10 **TIM3\_REMAP[1:0]**: TIM3 remapping  
These bits are set and cleared by software. They control the mapping of TIM3 channels 1 to 4 on the GPIO ports.  
00: No remap (CH1/PA6, CH2/PA7, CH3/PB0, CH4/PB1)  
01: Not used  
10: Partial remap (CH1/PB4, CH2/PB5, CH3/PB0, CH4/PB1)  
11: Full remap (CH1/PC6, CH2/PC7, CH3/PC8, CH4/PC9)  
*Note: TIM3\_ETR on PE0 is not re-mapped.*
- Bits 9:8 **TIM2\_REMAP[1:0]**: TIM2 remapping  
These bits are set and cleared by software. They control the mapping of TIM2 channels 1 to 4 and external trigger (ETR) on the GPIO ports.  
00: No remap (CH1/ETR/PA0, CH2/PA1, CH3/PA2, CH4/PA3)  
01: Partial remap (CH1/ETR/PA15, CH2/PB3, CH3/PA2, CH4/PA3)  
10: Partial remap (CH1/ETR/PA0, CH2/PA1, CH3/PB10, CH4/PB11)  
11: Full remap (CH1/ETR/PA15, CH2/PB3, CH3/PB10, CH4/PB11)

**Bits 7:6 TIM1\_REMAP[1:0]:** TIM1 remapping

These bits are set and cleared by software. They control the mapping of TIM2 channels 1 to 4, 1N to 3N, external trigger (ETR) and Break input (BKIN) on the GPIO ports.

00: No remap (ETR/PA12, CH1/PA8, CH2/PA9, CH3/PA10, CH4/PA11, BKIN/PB12, CH1N/PB13, CH2N/PB14, CH3N/PB15)

01: Partial remap (ETR/PA12, CH1/PA8, CH2/PA9, CH3/PA10, CH4/PA11, BKIN/PA6, CH1N/PA7, CH2N/PB0, CH3N/PB1)

10: not used

11: Full remap (ETR/PE7, CH1/PE9, CH2/PE11, CH3/PE13, CH4/PE14, BKIN/PE15, CH1N/PE8, CH2N/PE10, CH3N/PE12)

**Bits 5:4 USART3\_REMAP[1:0]:** USART3 remapping

These bits are set and cleared by software. They control the mapping of USART3 CTS, RTS,CK,TX and RX alternate functions on the GPIO ports.

00: No remap (TX/PB10, RX/PB11, CK/PB12, CTS/PB13, RTS/PB14)

01: Partial remap (TX/PC10, RX/PC11, CK/PC12, CTS/PB13, RTS/PB14)

10: not used

11: Full remap (TX/PD8, RX/PD9, CK/PD10, CTS/PD11, RTS/PD12)

**Bit 3 USART2\_REMAP:** USART2 remapping

This bit is set and cleared by software. It controls the mapping of USART2 CTS, RTS,CK,TX and RX alternate functions on the GPIO ports.

0: No remap (CTS/PA0, RTS/PA1, TX/PA2, RX/PA3, CK/PA4)

1: Remap (CTS/PD3, RTS/PD4, TX/PD5, RX/PD6, CK/PD7)

**Bit 2 USART1\_REMAP:** USART1 remapping

This bit is set and cleared by software. It controls the mapping of USART1 TX and RX alternate functions on the GPIO ports.

0: No remap (TX/PA9, RX/PA10)

1: Remap (TX/PB6, RX/PB7)

**Bit 1 I2C1\_REMAP:** I2C1 remapping

This bit is set and cleared by software. It controls the mapping of I2C1 SCL and SDA alternate functions on the GPIO ports.

0: No remap (SCL/PB6, SDA/PB7)

1: Remap (SCL/PB8, SDA/PB9)

**Bit 0 SPI1\_REMAP:** SPI1 remapping

This bit is set and cleared by software. It controls the mapping of SPI1 NSS, SCK, MISO, MOSI alternate functions on the GPIO ports.

0: No remap (NSS/PA4, SCK/PA5, MISO/PA6, MOSI/PA7)

1: Remap (NSS/PA15, SCK/PB3, MISO/PB4, MOSI/PB5)

**Memory map and bit definitions for connectivity line devices:**

31	30	29	28	27	26	25	24	23	22	21	20	19	18	17	16
Res.	PTP_PPS_REMAP	TIM2ITR1_IEMAP	SPI3_REMAP	Res.	SWJ_CFG[2:0]			MII_RMII_SEL	CAN2_REMAP	ETH_REMAP	Reserved				TIM5CH4_IEMAP
	rw	rw	rw		w	w	w	rw	rw	rw	rw	rw			
15	14	13	12	11	10	9	8	7	6	5	4	3	2	1	0
PD01_REMAP	CAN1_REMAP[1:0]	TIM4_REMAP	TIM3_REMAP[1:0]	TIM2_REMAP[1:0]	TIM1_REMAP[1:0]	USART3_REMAP[1:0]		USART2_REMAP	USART1_REMAP	I2C1_REMAP	SPI1_REMAP				
rw	rw	rw	rw	rw	rw	rw	rw	rw	rw	rw	rw	rw	rw	rw	rw

Bit 31 Reserved

Bit 30 **PTP\_PPS\_REMAP**: Ethernet PTP PPS remapping  
 This bit is set and cleared by software. It enables the Ethernet MAC PPS\_PTS to be output on the PB5 pin.  
 0: PTP\_PPS not output on PB5 pin.  
 1: PTP\_PPS is output on PB5 pin.  
*Note: This bit is available only in connectivity line devices and is reserved otherwise.*

Bit 29 **TIM2ITR1\_IEMAP**: TIM2 internal trigger 1 remapping  
 This bit is set and cleared by software. It controls the TIM2\_ITR1 internal mapping.  
 0: Connect TIM2\_ITR1 internally to the Ethernet PTP output for calibration purposes.  
 1: Connect USB OTG SOF (Start of Frame) output to TIM2\_ITR1 for calibration purposes.  
*Note: This bit is available only in connectivity line devices and is reserved otherwise.*

Bit 28 **SPI3\_REMAP**: SPI3/I2S3 remapping  
 This bit is set and cleared by software. It controls the mapping of SPI3\_NSS/I2S3\_WS, SPI3\_SCK/I2S3\_CK, SPI3\_MISO, SPI3\_MOSI/I2S3\_SD alternate functions on the GPIO ports.  
 0: No remap (SPI\_NSS-I2S3\_WS/PA15, SPI3\_SCK-I2S3\_CK/PB3, SPI3\_MISO/PB4, SPI3\_MOSI-I2S3\_SD/PB5)  
 1: Remap (SPI3\_NSS-I2S3\_WS/PA4, SPI3\_SCK-I2S3\_CK/PC10, SPI3\_MISO/PC11, SPI3\_MOSI-I2S3\_SD/PC12)  
*Note: This bit is available only in connectivity line devices and is reserved otherwise.*

Bit 27 Reserved

Bits 26:24 **SWJ\_CFG[2:0]**: Serial wire JTAG configuration  
 These bits are write-only (when read, the value is undefined). They are used to configure the SWJ and trace alternate function I/Os. The SWJ (Serial Wire JTAG) supports JTAG or SWD access to the Cortex debug port. The default state after reset is SWJ ON without trace. This allows JTAG or SW mode to be enabled by sending a specific sequence on the JTMS / JTCK pin.  
 000: Full SWJ (JTAG-DP + SW-DP): Reset State  
 001: Full SWJ (JTAG-DP + SW-DP) but without NJTRST  
 010: JTAG-DP Disabled and SW-DP Enabled  
 100: JTAG-DP Disabled and SW-DP Disabled  
 Other combinations: no effect

Bit 23 **MII\_RMII\_SEL**: MII or RMII selection  
 This bit is set and cleared by software. It configures the Ethernet MAC internally for use with an external MII or RMII PHY.  
 0: Configure Ethernet MAC for connection with an MII PHY  
 1: Configure Ethernet MAC for connection with an RMII PHY  
*Note: This bit is available only in connectivity line devices and is reserved otherwise.*

- Bit 22 **CAN2\_REMAP**: CAN2 I/O remapping  
This bit is set and cleared by software. It controls the CAN2\_TX and CAN2\_RX pins.  
0: No remap (CAN2\_RX/PB12, CAN2\_TX/PB13)  
1: Remap (CAN2\_RX/PB5, CAN2\_TX/PB6)  
*Note: This bit is available only in connectivity line devices and is reserved otherwise.*
- Bit 21 **ETH\_REMAP**: Ethernet MAC I/O remapping  
This bit is set and cleared by software. It controls the Ethernet MAC connections with the PHY.  
0: No remap (RX\_DV-CRS\_DV/PA7, RXD0/PC4, RXD1/PC5, RXD2/PB0, RXD3/PB1)  
1: Remap (RX\_DV-CRS\_DV/PD8, RXD0/PD9, RXD1/PD10, RXD2/PD11, RXD3/PD12)  
*Note: This bit is available only in connectivity line devices and is reserved otherwise.*
- Bits 20:17 Reserved
- Bits 16 **TIM5CH4\_IEMAP**: TIM5 channel4 internal remap  
Set and cleared by software. This bit controls the TIM5\_CH4 internal mapping. When reset the timer TIM5\_CH4 is connected to PA3. When set the LSI internal clock is connected to TIM5\_CH4 input for calibration purpose.
- Bit 15 **PD01\_REMAP**: Port D0/Port D1 mapping on OSC\_IN/OSC\_OUT  
This bit is set and cleared by software. It controls the mapping of PD0 and PD1 GPIO functionality. When the HSE oscillator is not used (application running on internal 8 MHz RC) PD0 and PD1 can be mapped on OSC\_IN and OSC\_OUT. This is available only on 36-, 48- and 64-pin packages (PD0 and PD1 are available on 100-pin and 144-pin packages, no need for remapping).  
0: No remapping of PD0 and PD1  
1: PD0 remapped on OSC\_IN, PD1 remapped on OSC\_OUT,
- Bits 14:13 **CAN1\_REMAP[1:0]**: CAN1 alternate function remapping  
These bits are set and cleared by software. They control the mapping of alternate functions CAN1\_RX and CAN1\_TX.  
00: CAN1\_RX mapped to PA11, CAN1\_TX mapped to PA12  
01: Not used  
10: CAN1\_RX mapped to PB8, CAN1\_TX mapped to PB9 (not available on 36-pin package)  
11: CAN1\_RX mapped to PD0, CAN1\_TX mapped to PD1
- Bit 12 **TIM4\_REMAP**: TIM4 remapping  
This bit is set and cleared by software. It controls the mapping of TIM4 channels 1 to 4 onto the GPIO ports.  
0: No remap (TIM4\_CH1/PB6, TIM4\_CH2/PB7, TIM4\_CH3/PB8, TIM4\_CH4/PB9)  
1: Full remap (TIM4\_CH1/PD12, TIM4\_CH2/PD13, TIM4\_CH3/PD14, TIM4\_CH4/PD15)  
*Note: TIM4\_ETR on PE0 is not re-mapped.*
- Bits 11:10 **TIM3\_REMAP[1:0]**: TIM3 remapping  
These bits are set and cleared by software. They control the mapping of TIM3 channels 1 to 4 on the GPIO ports.  
00: No remap (CH1/PA6, CH2/PA7, CH3/PB0, CH4/PB1)  
01: Not used  
10: Partial remap (CH1/PB4, CH2/PB5, CH3/PB0, CH4/PB1)  
11: Full remap (CH1/PC6, CH2/PC7, CH3/PC8, CH4/PC9)  
*Note: TIM3\_ETR on PE0 is not re-mapped.*

**Bits 9:8 TIM2\_REMAP[1:0]:** TIM2 remapping

These bits are set and cleared by software. They control the mapping of TIM2 channels 1 to 4 and external trigger (ETR) on the GPIO ports.

00: No remap (CH1/ETR/PA0, CH2/PA1, CH3/PA2, CH4/PA3)

01: Partial remap (CH1/ETR/PA15, CH2/PB3, CH3/PA2, CH4/PA3)

10: Partial remap (CH1/ETR/PA0, CH2/PA1, CH3/PB10, CH4/PB11)

11: Full remap (CH1/ETR/PA15, CH2/PB3, CH3/PB10, CH4/PB11)

**Bits 7:6 TIM1\_REMAP[1:0]:** TIM1 remapping

These bits are set and cleared by software. They control the mapping of TIM2 channels 1 to 4, 1N to 3N, external trigger (ETR) and Break input (BKIN) on the GPIO ports.

00: No remap (ETR/PA12, CH1/PA8, CH2/PA9, CH3/PA10, CH4/PA11, BKIN/PB12, CH1N/PB13, CH2N/PB14, CH3N/PB15)

01: Partial remap (ETR/PA12, CH1/PA8, CH2/PA9, CH3/PA10, CH4/PA11, BKIN/PA6, CH1N/PA7, CH2N/PB0, CH3N/PB1)

10: not used

11: Full remap (ETR/PE7, CH1/PE9, CH2/PE11, CH3/PE13, CH4/PE14, BKIN/PE15, CH1N/PE8, CH2N/PE10, CH3N/PE12)

**Bits 5:4 USART3\_REMAP[1:0]:** USART3 remapping

These bits are set and cleared by software. They control the mapping of USART3 CTS, RTS, CK, TX and RX alternate functions on the GPIO ports.

00: No remap (TX/PB10, RX/PB11, CK/PB12, CTS/PB13, RTS/PB14)

01: Partial remap (TX/PC10, RX/PC11, CK/PC12, CTS/PB13, RTS/PB14)

10: not used

11: Full remap (TX/PD8, RX/PD9, CK/PD10, CTS/PD11, RTS/PD12)

**Bit 3 USART2\_REMAP:** USART2 remapping

This bit is set and cleared by software. It controls the mapping of USART2 CTS, RTS, CK, TX and RX alternate functions on the GPIO ports.

0: No remap (CTS/PA0, RTS/PA1, TX/PA2, RX/PA3, CK/PA4)

1: Remap (CTS/PD3, RTS/PD4, TX/PD5, RX/PD6, CK/PD7)

**Bit 2 USART1\_REMAP:** USART1 remapping

This bit is set and cleared by software. It controls the mapping of USART1 TX and RX alternate functions on the GPIO ports.

0: No remap (TX/PA9, RX/PA10)

1: Remap (TX/PB6, RX/PB7)

**Bit 1 I2C1\_REMAP:** I2C1 remapping

This bit is set and cleared by software. It controls the mapping of I2C1 SCL and SDA alternate functions on the GPIO ports.

0: No remap (SCL/PB6, SDA/PB7)

1: Remap (SCL/PB8, SDA/PB9)

**Bit 0 SPI1\_REMAP:** SPI1 remapping

This bit is set and cleared by software. It controls the mapping of SPI1 NSS, SCK, MISO, MOSI alternate functions on the GPIO ports.

0: No remap (NSS/PA4, SCK/PA5, MISO/PA6, MOSI/PA7)

1: Remap (NSS/PA15, SCK/PB3, MISO/PB4, MOSI/PB5)

### 8.4.3 External interrupt configuration register 1 (AFIO\_EXTICR1)

Address offset: 0x08

Reset value: 0x0000

31	30	29	28	27	26	25	24	23	22	21	20	19	18	17	16
Reserved															
15	14	13	12	11	10	9	8	7	6	5	4	3	2	1	0
EXTI3[3:0]				EXTI2[3:0]				EXTI1[3:0]				EXTI0[3:0]			
rw	rw	rw	rw	rw	rw	rw	rw	rw	rw	rw	rw	rw	rw	rw	rw

Bits 31:16 Reserved

Bits 15:0 **EXTIx[3:0]**: EXTI x configuration (x= 0 to 3)

These bits are written by software to select the source input for EXTIx external interrupt.

Refer to [Section 9.2.5: External interrupt/event line mapping on page 191](#)

- 0000: PA[x] pin
- 0001: PB[x] pin
- 0010: PC[x] pin
- 0011: PD[x] pin
- 0100: PE[x] pin
- 0101: PF[x] pin
- 0110: PG[x] pin

### 8.4.4 External interrupt configuration register 2 (AFIO\_EXTICR2)

Address offset: 0x0C

Reset value: 0x0000

31	30	29	28	27	26	25	24	23	22	21	20	19	18	17	16
Reserved															
15	14	13	12	11	10	9	8	7	6	5	4	3	2	1	0
EXTI7[3:0]				EXTI6[3:0]				EXTI5[3:0]				EXTI4[3:0]			
rw	rw	rw	rw	rw	rw	rw	rw	rw	rw	rw	rw	rw	rw	rw	rw

Bits 31:16 Reserved

Bits 15:0 **EXTIx[3:0]**: EXTI x configuration (x= 4 to 7)

These bits are written by software to select the source input for EXTIx external interrupt.

- 0000: PA[x] pin
- 0001: PB[x] pin
- 0010: PC[x] pin
- 0011: PD[x] pin
- 0100: PE[x] pin
- 0101: PF[x] pin
- 0110: PG[x] pin



### 8.4.5 External interrupt configuration register 3 (AFIO\_EXTICR3)

Address offset: 0x10

Reset value: 0x0000

31	30	29	28	27	26	25	24	23	22	21	20	19	18	17	16
Reserved															
15	14	13	12	11	10	9	8	7	6	5	4	3	2	1	0
EXTI11[3:0]				EXTI10[3:0]				EXTI9[3:0]				EXTI8[3:0]			
rw	rw	rw	rw	rw	rw	rw	rw	rw	rw	rw	rw	rw	rw	rw	rw

Bits 31:16 Reserved

Bits 15:0 **EXTIx[3:0]**: EXTI x configuration (x= 8 to 11)

These bits are written by software to select the source input for EXTIx external interrupt.

- 0000: PA[x] pin
- 0001: PB[x] pin
- 0010: PC[x] pin
- 0011: PD[x] pin
- 0100: PE[x] pin
- 0101: PF[x] pin
- 0110: PG[x] pin

### 8.4.6 External interrupt configuration register 4 (AFIO\_EXTICR4)

Address offset: 0x14

Reset value: 0x0000

31	30	29	28	27	26	25	24	23	22	21	20	19	18	17	16
Reserved															
15	14	13	12	11	10	9	8	7	6	5	4	3	2	1	0
EXTI15[3:0]				EXTI14[3:0]				EXTI13[3:0]				EXTI12[3:0]			
rw	rw	rw	rw	rw	rw	rw	rw	rw	rw	rw	rw	rw	rw	rw	rw

Bits 31:16 Reserved

Bits 15:0 **EXTIx[3:0]**: EXTI x configuration (x= 12 to 15)

These bits are written by software to select the source input for EXTIx external interrupt.

- 0000: PA[x] pin
- 0001: PB[x] pin
- 0010: PC[x] pin
- 0011: PD[x] pin
- 0100: PE[x] pin
- 0101: PF[x] pin
- 0110: PG[x] pin

### 8.4.7 AF remap and debug I/O configuration register2 (AFIO\_MAPR2)

Address offset: 0x1C

Reset value: 0x0000 0000

31	30	29	28	27	26	25	24	23	22	21	20	19	18	17	16	
Reserved																
15	14	13	12	11	10	9	8	7	6	5	4	3	2	1	0	
Reserved				FSMC_NADV	TIM14_REMAP	TIM13_REMAP	TIM11_REMAP	TIM10_REMAP	TIM9_REMAP	Reserved						
				rw	rw	rw	rw	rw	rw							

Bits 31:11 Reserved.

Bit 10 **FSMC\_NADV**: NADV connect/disconnect

This bit is set and cleared by software. It controls the use of the optional FSMC\_NADV signal.

0: The NADV signal is connected to the output (default)

1: The NADV signal is *not* connected. The I/O pin can be used by another peripheral.

Bit 9 **TIM14\_REMAP**: TIM14 remapping

This bit is set and cleared by software. It controls the mapping of the TIM14\_CH1 alternate function onto the GPIO ports.

0: No remap (PA7)

1: Remap (PF9)

Bit 8 **TIM13\_REMAP**: TIM13 remapping

This bit is set and cleared by software. It controls the mapping of the TIM13\_CH1 alternate function onto the GPIO ports.

0: No remap (PA6)

1: Remap (PF8)

Bit 7 **TIM11\_REMAP**: TIM11 remapping

This bit is set and cleared by software. It controls the mapping of the TIM11\_CH1 alternate function onto the GPIO ports.

0: No remap (PB9)

1: Remap (PF7)

Bit 6 **TIM10\_REMAP**: TIM10 remapping

This bit is set and cleared by software. It controls the mapping of the TIM10\_CH1 alternate function onto the GPIO ports.

0: No remap (PB8)

1: Remap (PF6)

Bit 5 **TIM9\_REMAP**: TIM9 remapping

This bit is set and cleared by software. It controls the mapping of the TIM9\_CH1 and TIM9\_CH2 alternate functions onto the GPIO ports.

0: No remap (TIM9\_CH1 on PA2 and TIM9\_CH2 on PA3)

1: Remap (TIM9\_CH1 on PE5 and TIM9\_CH2 on PE6)

Bits 4:0 Reserved.

## 8.5 GPIO and AFIO register maps

Refer to [Table 1 on page 44](#) for the register boundary addresses. The following tables give the GPIO and AFIO register map and the reset values.

**Table 57. GPIO register map and reset values**

Offset	Register	31	30	29	28	27	26	25	24	23	22	21	20	19	18	17	16	15	14	13	12	11	10	9	8	7	6	5	4	3	2	1	0																	
0x00	GPIOx_CRL	CNF7 [1:0]	MODE7 [1:0]	CNF6 [1:0]	MODE6 [1:0]	CNF5 [1:0]	MODE5 [1:0]	CNF4 [1:0]	MODE4 [1:0]	CNF3 [1:0]	MODE3 [1:0]	CNF2 [1:0]	MODE2 [1:0]	CNF1 [1:0]	MODE1 [1:0]	CNF0 [1:0]	MODE0 [1:0]																																	
	Reset value	0	1	0	0	0	1	0	0	0	1	0	0	0	1	0	0	0	1	0	0	0	1	0	0	0	1	0	0	0	1	0	0																	
0x04	GPIOx_CRH	CNF15 [1:0]	MODE15 [1:0]	CNF14 [1:0]	MODE14 [1:0]	CNF13 [1:0]	MODE13 [1:0]	CNF12 [1:0]	MODE12 [1:0]	CNF11 [1:0]	MODE11 [1:0]	CNF10 [1:0]	MODE10 [1:0]	CNF9 [1:0]	MODE9 [1:0]	CNF8 [1:0]	MODE8 [1:0]																																	
	Reset value	0	1	0	0	0	1	0	0	0	1	0	0	0	1	0	0	0	1	0	0	0	1	0	0	0	1	0	0	0	1	0	0																	
0x08	GPIOx_IDR	Reserved																IDR[15:0]																																
	Reset value																	0	0	0	0	0	0	0	0	0	0	0	0	0	0	0	0	0	0	0	0	0	0	0	0	0	0	0	0	0	0			
0x0C	GPIOx_ODR	Reserved																ODR[15:0]																																
	Reset value																	0	0	0	0	0	0	0	0	0	0	0	0	0	0	0	0	0	0	0	0	0	0	0	0	0	0	0	0	0	0	0	0	0
0x10	GPIOx_BSRR	BR[15:0]																BSR[15:0]																																
	Reset value	0	0	0	0	0	0	0	0	0	0	0	0	0	0	0	0	0	0	0	0	0	0	0	0	0	0	0	0	0	0	0	0	0																
0x14	GPIOx_BRR	Reserved																BR[15:0]																																
	Reset value																	0	0	0	0	0	0	0	0	0	0	0	0	0	0	0	0	0	0	0	0	0	0	0	0	0	0	0	0	0	0	0	0	
0x18	GPIOx_LCKR	Reserved																LCKK	LCK[15:0]																															
	Reset value																	0	0	0	0	0	0	0	0	0	0	0	0	0	0	0	0	0	0	0	0	0	0	0	0	0	0	0	0	0	0	0	0	0

**Table 58. AFIO register map and reset values**

Offset	Register	31	30	29	28	27	26	25	24	23	22	21	20	19	18	17	16	15	14	13	12	11	10	9	8	7	6	5	4	3	2	1	0																																																		
0x00	AFIO_EVCR	Reserved																								EVOE	PORT[2:0]			PIN[3:0]																																																					
	Reset value																									0	0	0	0	0	0	0	0																																																		
0x04	AFIO_MAPR low-, medium-, high- and XL- density devices	Reserved				SWJ_CFG[2]			Reserved			ADC2_ETRGREG_REMAP			ADC2_ETRGINJ_REMAP			ADC1_ETRGREG_REMAP			ADC1_ETRGINJ_REMAP			TIM5CH4_IEMAP			PD01_REMAP			CAN1_REMAP[1]			CAN1_REMAP[0]			TIM4_REMAP			TIM3_REMAP[1]			TIM3_REMAP[0]			TIM2_REMAP[1]			TIM2_REMAP[0]			TIM1_REMAP[1]			TIM1_REMAP[0]			USART3_REMAP[1]			USART3_REMAP[0]			USART2_REMAP			USART1_REMAP			I2C1_REMAP			SPI1_REMAP											
	Reset value					0	0	0	0				0	0	0	0	0	0	0	0	0	0	0	0	0	0	0	0	0	0	0	0	0	0	0	0	0	0	0	0	0	0	0	0	0	0	0	0	0	0	0	0																															
0x04	AFIO_MAPR connectivity line devices	Reserved		PTP_PPS_REMAP		TIM2ITR1_IEMAP		SPI3_REMAP		Reserved		SWJ_CFG[2]			SWJ_CFG[1]			SWJ_CFG[0]			MII_RMII_SEL			CAN2_REMAP			ETH_REMAP			Reserved			TIM5CH4_IEMAP			PD01_REMAP			CAN1_REMAP[1]			CAN1_REMAP[0]			TIM4_REMAP			TIM3_REMAP[1]			TIM3_REMAP[0]			TIM2_REMAP[1]			TIM2_REMAP[0]			TIM1_REMAP[1]			TIM1_REMAP[0]			USART3_REMAP[1]			USART3_REMAP[0]			USART2_REMAP			USART1_REMAP			I2C1_REMAP			SPI1_REMAP		
	Reset value	0	0	0	0	0	0	0	0	0	0	0	0	0	0	0	0	0	0	0	0	0	0	0	0	0	0	0	0	0	0	0	0	0	0	0	0	0	0	0	0	0	0	0	0	0	0	0	0	0	0	0	0	0	0	0	0																										
0x08	AFIO_EXTICR1	Reserved																EXTI3[3:0]			EXTI2[3:0]			EXTI1[3:0]			EXTI0[3:0]																																																								
	Reset value																	0	0	0	0	0	0	0	0	0	0	0	0	0	0	0	0	0	0	0	0																																														
0x0C	AFIO_EXTICR2	Reserved																EXTI7[3:0]			EXTI6[3:0]			EXTI5[3:0]			EXTI4[3:0]																																																								
	Reset value																	0	0	0	0	0	0	0	0	0	0	0	0	0	0	0	0	0	0	0	0																																														

**Table 58. AFIO register map and reset values (continued)**

Offset	Register	31	30	29	28	27	26	25	24	23	22	21	20	19	18	17	16	15	14	13	12	11	10	9	8	7	6	5	4	3	2	1	0					
0x10	<b>AFIO_EXTICR3</b>	Reserved																EXTI11[3:0]			EXTI10[3:0]			EXTI9[3:0]			EXTI8[3:0]											
	Reset value																	0	0	0	0	0	0	0	0	0	0	0	0	0	0	0	0					
0x14	<b>AFIO_EXTICR4</b>	Reserved																EXTI15[3:0]			EXTI14[3:0]			EXTI13[3:0]			EXTI12[3:0]											
	Reset value																	0	0	0	0	0	0	0	0	0	0	0	0	0	0	0	0					
0x1C	<b>AFIO_MAPR2</b>	Reserved																				FSMC_NADV	TIM14_REMAP	TIM13_REMAP	TIM11_REMAP	TIM10_REMAP	TIM9_REMAP	Reserved										
	Reset value																					0	0	0	0	0	0											

Refer to [Table 1 on page 44](#) for the register boundary addresses.

## 9 Interrupts and events

**Low-density devices** are STM32F101xx, STM32F102xx and STM32F103xx microcontrollers where the Flash memory density ranges between 16 and 32 Kbytes.

**Medium-density devices** are STM32F101xx, STM32F102xx and STM32F103xx microcontrollers where the Flash memory density ranges between 64 and 128 Kbytes.

**High-density devices** are STM32F101xx and STM32F103xx microcontrollers where the Flash memory density ranges between 256 and 512 Kbytes.

**XL-density devices** are STM32F101xx and STM32F103xx microcontrollers where the Flash memory density ranges between 768 Kbytes and 1 Mbyte.

**Connectivity line devices** are STM32F105xx and STM32F107xx microcontrollers.

This Section applies to the whole STM32F10xxx family, unless otherwise specified.

### 9.1 Nested vectored interrupt controller (NVIC)

#### Features

- 68 maskable interrupt channels (not including the 16 interrupt lines of Cortex™-M3)
- 16 programmable priority levels (4 bits of interrupt priority are used)
- Low-latency exception and interrupt handling
- Power management control
- Implementation of System Control Registers

The NVIC and the processor core interface are closely coupled, which enables low latency interrupt processing and efficient processing of late arriving interrupts.

All interrupts including the core exceptions are managed by the NVIC. For more information on exceptions and NVIC programming, refer to *STM32F10xxx Cortex-M3 programming manual* (see [Related documents on page 1](#)).

#### 9.1.1 SysTick calibration value register

The SysTick calibration value is set to 9000, which gives a reference time base of 1 ms with the SysTick clock set to 9 MHz (max HCLK/8).

#### 9.1.2 Interrupt and exception vectors

[Table 59](#) and [Table 61](#) are the vector tables for connectivity line and other STM32F10xxx devices, respectively.

**Table 59. Vector table for connectivity line devices**

Position	Priority	Type of priority	Acronym	Description	Address
	-	-	-	Reserved	0x0000_0000
	-3	fixed	Reset	Reset	0x0000_0004

**Table 59. Vector table for connectivity line devices (continued)**

Position	Priority	Type of priority	Acronym	Description	Address
	-2	fixed	NMI	Non maskable interrupt. The RCC Clock Security System (CSS) is linked to the NMI vector.	0x0000_0008
	-1	fixed	HardFault	All class of fault	0x0000_000C
	0	settable	MemManage	Memory management	0x0000_0010
	1	settable	BusFault	Pre-fetch fault, memory access fault	0x0000_0014
	2	settable	UsageFault	Undefined instruction or illegal state	0x0000_0018
	-	-	-	Reserved	0x0000_001C - 0x0000_002B
	3	settable	SVCall	System service call via SWI instruction	0x0000_002C
	4	settable	Debug Monitor	Debug Monitor	0x0000_0030
	-	-	-	Reserved	0x0000_0034
	5	settable	PendSV	Pendable request for system service	0x0000_0038
	6	settable	SysTick	System tick timer	0x0000_003C
0	7	settable	WWDG	Window Watchdog interrupt	0x0000_0040
1	8	settable	PVD	PVD through EXTI Line detection interrupt	0x0000_0044
2	9	settable	TAMPER	Tamper interrupt	0x0000_0048
3	10	settable	RTC	RTC global interrupt	0x0000_004C
4	11	settable	FLASH	Flash global interrupt	0x0000_0050
5	12	settable	RCC	RCC global interrupt	0x0000_0054
6	13	settable	EXTI0	EXTI Line0 interrupt	0x0000_0058
7	14	settable	EXTI1	EXTI Line1 interrupt	0x0000_005C
8	15	settable	EXTI2	EXTI Line2 interrupt	0x0000_0060
9	16	settable	EXTI3	EXTI Line3 interrupt	0x0000_0064
10	17	settable	EXTI4	EXTI Line4 interrupt	0x0000_0068
11	18	settable	DMA1_Channel1	DMA1 Channel1 global interrupt	0x0000_006C
12	19	settable	DMA1_Channel2	DMA1 Channel2 global interrupt	0x0000_0070
13	20	settable	DMA1_Channel3	DMA1 Channel3 global interrupt	0x0000_0074
14	21	settable	DMA1_Channel4	DMA1 Channel4 global interrupt	0x0000_0078
15	22	settable	DMA1_Channel5	DMA1 Channel5 global interrupt	0x0000_007C
16	23	settable	DMA1_Channel6	DMA1 Channel6 global interrupt	0x0000_0080
17	24	settable	DMA1_Channel7	DMA1 Channel7 global interrupt	0x0000_0084
18	25	settable	ADC1_2	ADC1 and ADC2 global interrupt	0x0000_0088

Table 59. Vector table for connectivity line devices (continued)

Position	Priority	Type of priority	Acronym	Description	Address
19	26	settable	CAN1_TX	CAN1 TX interrupts	0x0000_008C
20	27	settable	CAN1_RX0	CAN1 RX0 interrupts	0x0000_0090
21	28	settable	CAN1_RX1	CAN1 RX1 interrupt	0x0000_0094
22	29	settable	CAN1_SCE	CAN1 SCE interrupt	0x0000_0098
23	30	settable	EXTI9_5	EXTI Line[9:5] interrupts	0x0000_009C
24	31	settable	TIM1_BRK	TIM1 Break interrupt	0x0000_00A0
25	32	settable	TIM1_UP	TIM1 Update interrupt	0x0000_00A4
26	33	settable	TIM1_TRG_COM	TIM1 Trigger and Commutation interrupts	0x0000_00A8
27	34	settable	TIM1_CC	TIM1 Capture Compare interrupt	0x0000_00AC
28	35	settable	TIM2	TIM2 global interrupt	0x0000_00B0
29	36	settable	TIM3	TIM3 global interrupt	0x0000_00B4
30	37	settable	TIM4	TIM4 global interrupt	0x0000_00B8
31	38	settable	I2C1_EV	I <sup>2</sup> C1 event interrupt	0x0000_00BC
32	39	settable	I2C1_ER	I <sup>2</sup> C1 error interrupt	0x0000_00C0
33	40	settable	I2C2_EV	I <sup>2</sup> C2 event interrupt	0x0000_00C4
34	41	settable	I2C2_ER	I <sup>2</sup> C2 error interrupt	0x0000_00C8
35	42	settable	SPI1	SPI1 global interrupt	0x0000_00CC
36	43	settable	SPI2	SPI2 global interrupt	0x0000_00D0
37	44	settable	USART1	USART1 global interrupt	0x0000_00D4
38	45	settable	USART2	USART2 global interrupt	0x0000_00D8
39	46	settable	USART3	USART3 global interrupt	0x0000_00DC
40	47	settable	EXTI15_10	EXTI Line[15:10] interrupts	0x0000_00E0
41	48	settable	RTCAlarm	RTC alarm through EXTI line interrupt	0x0000_00E4
42	49	settable	OTG_FS_WKUP	USB On-The-Go FS Wakeup through EXTI line interrupt	0x0000_00E8
-	-	-	-	Reserved	0x0000_00EC - 0x0000_0104
50	57	settable	TIM5	TIM5 global interrupt	0x0000_0108
51	58	settable	SPI3	SPI3 global interrupt	0x0000_010C
52	59	settable	UART4	UART4 global interrupt	0x0000_0110
53	60	settable	UART5	UART5 global interrupt	0x0000_0114
54	61	settable	TIM6	TIM6 global interrupt	0x0000_0118
55	62	settable	TIM7	TIM7 global interrupt	0x0000_011C

**Table 59. Vector table for connectivity line devices (continued)**

Position	Priority	Type of priority	Acronym	Description	Address
56	63	settable	DMA2_Channel1	DMA2 Channel1 global interrupt	0x0000_0120
57	64	settable	DMA2_Channel2	DMA2 Channel2 global interrupt	0x0000_0124
58	65	settable	DMA2_Channel3	DMA2 Channel3 global interrupt	0x0000_0128
59	66	settable	DMA2_Channel4	DMA2 Channel4 global interrupt	0x0000_012C
60	67	settable	DMA2_Channel5	DMA2 Channel5 global interrupt	0x0000_0130
61	68	settable	ETH	Ethernet global interrupt	0x0000_0134
62	69	settable	ETH_WKUP	Ethernet Wakeup through EXT1 line interrupt	0x0000_0138
63	70	settable	CAN2_TX	CAN2 TX interrupts	0x0000_013C
64	71	settable	CAN2_RX0	CAN2 RX0 interrupts	0x0000_0140
65	72	settable	CAN2_RX1	CAN2 RX1 interrupt	0x0000_0144
66	73	settable	CAN2_SCE	CAN2 SCE interrupt	0x0000_0148
67	74	settable	OTG_FS	USB On The Go FS global interrupt	0x0000_014C

**Table 60. Vector table for XL-density devices**

Position	Priority	Type of priority	Acronym	Description	Address
	-	-	-	Reserved	0x0000_0000
	-3	fixed	Reset	Reset	0x0000_0004
	-2	fixed	NMI	Nonmaskable interrupt. The RCC Clock Security System (CSS) is linked to the NMI vector.	0x0000_0008
	-1	fixed	HardFault	All class of fault	0x0000_000C
	0	settable	MemManage	Memory management	0x0000_0010
	1	settable	BusFault	Prefetch fault, memory access fault	0x0000_0014
	2	settable	UsageFault	Undefined instruction or illegal state	0x0000_0018
	-	-	-	Reserved	0x0000_001C - 0x0000_002B
	3	settable	SVCall	System service call via SWI instruction	0x0000_002C
	4	settable	Debug Monitor	Debug monitor	0x0000_0030
	-	-	-	Reserved	0x0000_0034
	5	settable	PendSV	Pendable request for system service	0x0000_0038
	6	settable	SysTick	Systick timer	0x0000_003C
0	7	settable	WWDG	Window watchdog interrupt	0x0000_0040



Table 60. Vector table for XL-density devices (continued)

Position	Priority	Type of priority	Acronym	Description	Address
1	8	settable	PVD	PVD through EXTI Line detection interrupt	0x0000_0044
2	9	settable	TAMPER	Tamper interrupt	0x0000_0048
3	10	settable	RTC	RTC global interrupt	0x0000_004C
4	11	settable	FLASH	Flash global interrupt	0x0000_0050
5	12	settable	RCC	RCC global interrupt	0x0000_0054
6	13	settable	EXTI0	EXTI Line0 interrupt	0x0000_0058
7	14	settable	EXTI1	EXTI Line1 interrupt	0x0000_005C
8	15	settable	EXTI2	EXTI Line2 interrupt	0x0000_0060
9	16	settable	EXTI3	EXTI Line3 interrupt	0x0000_0064
10	17	settable	EXTI4	EXTI Line4 interrupt	0x0000_0068
11	18	settable	DMA1_Channel1	DMA1 Channel1 global interrupt	0x0000_006C
12	19	settable	DMA1_Channel2	DMA1 Channel2 global interrupt	0x0000_0070
13	20	settable	DMA1_Channel3	DMA1 Channel3 global interrupt	0x0000_0074
14	21	settable	DMA1_Channel4	DMA1 Channel4 global interrupt	0x0000_0078
15	22	settable	DMA1_Channel5	DMA1 Channel5 global interrupt	0x0000_007C
16	23	settable	DMA1_Channel6	DMA1 Channel6 global interrupt	0x0000_0080
17	24	settable	DMA1_Channel7	DMA1 Channel7 global interrupt	0x0000_0084
18	25	settable	ADC1_2	ADC1 and ADC2 global interrupt	0x0000_0088
19	26	settable	USB_HP_CAN_TX	USB high priority or CAN TX interrupts	0x0000_008C
20	27	settable	USB_LP_CAN_RX0	USB low priority or CAN RX0 interrupts	0x0000_0090
21	28	settable	CAN_RX1	CAN RX1 interrupt	0x0000_0094
22	29	settable	CAN_SCE	CAN SCE interrupt	0x0000_0098
23	30	settable	EXTI9_5	EXTI Line[9:5] interrupts	0x0000_009C
24	31	settable	TIM1_BRK_TIM9	TIM1 Break interrupt and TIM9 global interrupt	0x0000_00A0
25	32	settable	TIM1_UP_TIM10	TIM1 Update interrupt and TIM10 global interrupt	0x0000_00A4
26	33	settable	TIM1_TRG_COM_TIM11	TIM1 Trigger and Commutation interrupts and TIM11 global interrupt	0x0000_00A8
27	34	settable	TIM1_CC	TIM1 Capture Compare interrupt	0x0000_00AC
28	35	settable	TIM2	TIM2 global interrupt	0x0000_00B0
29	36	settable	TIM3	TIM3 global interrupt	0x0000_00B4
30	37	settable	TIM4	TIM4 global interrupt	0x0000_00B8

**Table 60. Vector table for XL-density devices (continued)**

Position	Priority	Type of priority	Acronym	Description	Address
31	38	settable	I2C1_EV	I2C1 event interrupt	0x0000_00BC
32	39	settable	I2C1_ER	I2C1 error interrupt	0x0000_00C0
33	40	settable	I2C2_EV	I2C2 event interrupt	0x0000_00C4
34	41	settable	I2C2_ER	I2C2 error interrupt	0x0000_00C8
35	42	settable	SPI1	SPI1 global interrupt	0x0000_00CC
36	43	settable	SPI2	SPI2 global interrupt	0x0000_00D0
37	44	settable	USART1	USART1 global interrupt	0x0000_00D4
38	45	settable	USART2	USART2 global interrupt	0x0000_00D8
39	46	settable	USART3	USART3 global interrupt	0x0000_00DC
40	47	settable	EXTI15_10	EXTI Line[15:10] interrupts	0x0000_00E0
41	48	settable	RTCAlarm	RTC alarm through EXTI line interrupt	0x0000_00E4
42	49	settable	USBWakeUp	USB wakeup from suspend through EXTI line interrupt	0x0000_00E8
43	50	settable	TIM8_BRK_TIM12	TIM8 Break interrupt and TIM12 global interrupt	0x0000_00EC
44	51	settable	TIM8_UP_TIM13	TIM8 Update interrupt and TIM13 global interrupt	0x0000_00F0
45	52	settable	TIM8_TRG_COM_TIM14	TIM8 Trigger and Commutation interrupts and TIM14 global interrupt	0x0000_00F4
46	53	settable	TIM8_CC	TIM8 Capture Compare interrupt	0x0000_00F8
47	54	settable	ADC3	ADC3 global interrupt	0x0000_00FC
48	55	settable	FSMC	FSMC global interrupt	0x0000_0100
49	56	settable	SDIO	SDIO global interrupt	0x0000_0104
50	57	settable	TIM5	TIM5 global interrupt	0x0000_0108
51	58	settable	SPI3	SPI3 global interrupt	0x0000_010C
52	59	settable	UART4	UART4 global interrupt	0x0000_0110
53	60	settable	UART5	UART5 global interrupt	0x0000_0114
54	61	settable	TIM6	TIM6 global interrupt	0x0000_0118
55	62	settable	TIM7	TIM7 global interrupt	0x0000_011C
56	63	settable	DMA2_Channel1	DMA2 Channel1 global interrupt	0x0000_0120
57	64	settable	DMA2_Channel2	DMA2 Channel2 global interrupt	0x0000_0124
58	65	settable	DMA2_Channel3	DMA2 Channel3 global interrupt	0x0000_0128
59	66	settable	DMA2_Channel4_5	DMA2 Channel4 and DMA2 Channel5 global interrupts	0x0000_012C

Table 61. Vector table for other STM32F10xxx devices

Position	Priority	Type of priority	Acronym	Description	Address
	-	-	-	Reserved	0x0000_0000
	-3	fixed	Reset	Reset	0x0000_0004
	-2	fixed	NMI	Non maskable interrupt. The RCC Clock Security System (CSS) is linked to the NMI vector.	0x0000_0008
	-1	fixed	HardFault	All class of fault	0x0000_000C
	0	settable	MemManage	Memory management	0x0000_0010
	1	settable	BusFault	Prefetch fault, memory access fault	0x0000_0014
	2	settable	UsageFault	Undefined instruction or illegal state	0x0000_0018
	-	-	-	Reserved	0x0000_001C - 0x0000_002B
	3	settable	SVCall	System service call via SWI instruction	0x0000_002C
	4	settable	Debug Monitor	Debug Monitor	0x0000_0030
	-	-	-	Reserved	0x0000_0034
	5	settable	PendSV	Pendable request for system service	0x0000_0038
	6	settable	SysTick	System tick timer	0x0000_003C
0	7	settable	WWDG	Window watchdog interrupt	0x0000_0040
1	8	settable	PVD	PVD through EXTI Line detection interrupt	0x0000_0044
2	9	settable	TAMPER	Tamper interrupt	0x0000_0048
3	10	settable	RTC	RTC global interrupt	0x0000_004C
4	11	settable	FLASH	Flash global interrupt	0x0000_0050
5	12	settable	RCC	RCC global interrupt	0x0000_0054
6	13	settable	EXTI0	EXTI Line0 interrupt	0x0000_0058
7	14	settable	EXTI1	EXTI Line1 interrupt	0x0000_005C
8	15	settable	EXTI2	EXTI Line2 interrupt	0x0000_0060
9	16	settable	EXTI3	EXTI Line3 interrupt	0x0000_0064
10	17	settable	EXTI4	EXTI Line4 interrupt	0x0000_0068
11	18	settable	DMA1_Channel1	DMA1 Channel1 global interrupt	0x0000_006C
12	19	settable	DMA1_Channel2	DMA1 Channel2 global interrupt	0x0000_0070
13	20	settable	DMA1_Channel3	DMA1 Channel3 global interrupt	0x0000_0074
14	21	settable	DMA1_Channel4	DMA1 Channel4 global interrupt	0x0000_0078
15	22	settable	DMA1_Channel5	DMA1 Channel5 global interrupt	0x0000_007C
16	23	settable	DMA1_Channel6	DMA1 Channel6 global interrupt	0x0000_0080

**Table 61. Vector table for other STM32F10xxx devices (continued)**

Position	Priority	Type of priority	Acronym	Description	Address
17	24	settable	DMA1_Channel7	DMA1 Channel7 global interrupt	0x0000_0084
18	25	settable	ADC1_2	ADC1 and ADC2 global interrupt	0x0000_0088
19	26	settable	USB_HP_CAN_TX	USB High Priority or CAN TX interrupts	0x0000_008C
20	27	settable	USB_LP_CAN_RX0	USB Low Priority or CAN RX0 interrupts	0x0000_0090
21	28	settable	CAN_RX1	CAN RX1 interrupt	0x0000_0094
22	29	settable	CAN_SCE	CAN SCE interrupt	0x0000_0098
23	30	settable	EXTI9_5	EXTI Line[9:5] interrupts	0x0000_009C
24	31	settable	TIM1_BRK	TIM1 Break interrupt	0x0000_00A0
25	32	settable	TIM1_UP	TIM1 Update interrupt	0x0000_00A4
26	33	settable	TIM1_TRG_COM	TIM1 Trigger and Commutation interrupts	0x0000_00A8
27	34	settable	TIM1_CC	TIM1 Capture Compare interrupt	0x0000_00AC
28	35	settable	TIM2	TIM2 global interrupt	0x0000_00B0
29	36	settable	TIM3	TIM3 global interrupt	0x0000_00B4
30	37	settable	TIM4	TIM4 global interrupt	0x0000_00B8
31	38	settable	I2C1_EV	I <sup>2</sup> C1 event interrupt	0x0000_00BC
32	39	settable	I2C1_ER	I <sup>2</sup> C1 error interrupt	0x0000_00C0
33	40	settable	I2C2_EV	I <sup>2</sup> C2 event interrupt	0x0000_00C4
34	41	settable	I2C2_ER	I <sup>2</sup> C2 error interrupt	0x0000_00C8
35	42	settable	SPI1	SPI1 global interrupt	0x0000_00CC
36	43	settable	SPI2	SPI2 global interrupt	0x0000_00D0
37	44	settable	USART1	USART1 global interrupt	0x0000_00D4
38	45	settable	USART2	USART2 global interrupt	0x0000_00D8
39	46	settable	USART3	USART3 global interrupt	0x0000_00DC
40	47	settable	EXTI15_10	EXTI Line[15:10] interrupts	0x0000_00E0
41	48	settable	RTCAlarm	RTC alarm through EXTI line interrupt	0x0000_00E4
42	49	settable	USBWakeup	USB wakeup from suspend through EXTI line interrupt	0x0000_00E8
43	50	settable	TIM8_BRK	TIM8 Break interrupt	0x0000_00EC
44	51	settable	TIM8_UP	TIM8 Update interrupt	0x0000_00F0
45	52	settable	TIM8_TRG_COM	TIM8 Trigger and Commutation interrupts	0x0000_00F4
46	53	settable	TIM8_CC	TIM8 Capture Compare interrupt	0x0000_00F8

**Table 61. Vector table for other STM32F10xxx devices (continued)**

Position	Priority	Type of priority	Acronym	Description	Address
47	54	settable	ADC3	ADC3 global interrupt	0x0000_00FC
48	55	settable	FSMC	FSMC global interrupt	0x0000_0100
49	56	settable	SDIO	SDIO global interrupt	0x0000_0104
50	57	settable	TIM5	TIM5 global interrupt	0x0000_0108
51	58	settable	SPI3	SPI3 global interrupt	0x0000_010C
52	59	settable	UART4	UART4 global interrupt	0x0000_0110
53	60	settable	UART5	UART5 global interrupt	0x0000_0114
54	61	settable	TIM6	TIM6 global interrupt	0x0000_0118
55	62	settable	TIM7	TIM7 global interrupt	0x0000_011C
56	63	settable	DMA2_Channel1	DMA2 Channel1 global interrupt	0x0000_0120
57	64	settable	DMA2_Channel2	DMA2 Channel2 global interrupt	0x0000_0124
58	65	settable	DMA2_Channel3	DMA2 Channel3 global interrupt	0x0000_0128
59	66	settable	DMA2_Channel4_5	DMA2 Channel4 and DMA2 Channel5 global interrupts	0x0000_012C

## 9.2 External interrupt/event controller (EXTI)

The external interrupt/event controller consists of up to 20 edge detectors in connectivity line devices, or 19 edge detectors in other devices for generating event/interrupt requests. Each input line can be independently configured to select the type (pulse or pending) and the corresponding trigger event (rising or falling or both). Each line can also be masked independently. A pending register maintains the status line of the interrupt requests.

### 9.2.1 Main features

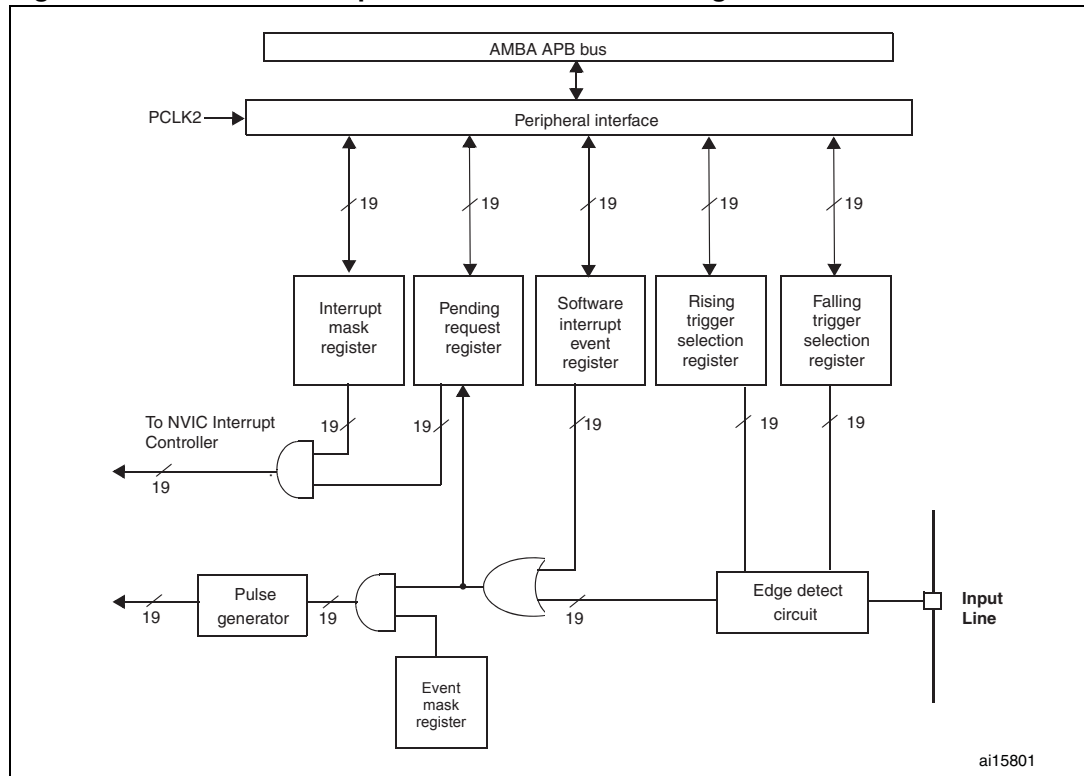
The EXTI controller main features are the following:

- Independent trigger and mask on each interrupt/event line
- Dedicated status bit for each interrupt line
- Generation of up to 20 software event/interrupt requests
- Detection of external signal with pulse width lower than APB2 clock period. Refer to the electrical characteristics section of the datasheet for details on this parameter.

### 9.2.2 Block diagram

The block diagram is shown in [Figure 20](#).

Figure 20. External interrupt/event controller block diagram



### 9.2.3 Wakeup event management

The STM32F10xxx is able to handle external or internal events in order to wake up the core (WFE). The wakeup event can be generated either by:

- enabling an interrupt in the peripheral control register but not in the NVIC, and enabling the SEVONPEND bit in the Cortex-M3 System Control register. When the MCU resumes from WFE, the peripheral interrupt pending bit and the peripheral NVIC IRQ channel pending bit (in the NVIC interrupt clear pending register) have to be cleared.
- or configuring an external or internal EXTI line in event mode. When the CPU resumes from WFE, it is not necessary to clear the peripheral interrupt pending bit or the NVIC IRQ channel pending bit as the pending bit corresponding to the event line is not set.

In connectivity line devices, Ethernet wakeup events also have the WFE wakeup capability.

To use an external line as a wakeup event, refer to [Section 9.2.4: Functional description](#).

### 9.2.4 Functional description

To generate the interrupt, the interrupt line should be configured and enabled. This is done by programming the two trigger registers with the desired edge detection and by enabling the interrupt request by writing a '1' to the corresponding bit in the interrupt mask register. When the selected edge occurs on the external interrupt line, an interrupt request is generated. The pending bit corresponding to the interrupt line is also set. This request is reset by writing a '1' in the pending register.

To generate the event, the event line should be configured and enabled. This is done by programming the two trigger registers with the desired edge detection and by enabling the

event request by writing a '1' to the corresponding bit in the event mask register. When the selected edge occurs on the event line, an event pulse is generated. The pending bit corresponding to the event line is not set

An interrupt/event request can also be generated by software by writing a '1' in the software interrupt/event register.

### Hardware interrupt selection

To configure the 20 lines as interrupt sources, use the following procedure:

- Configure the mask bits of the 20 Interrupt lines (EXTI\_IMR)
- Configure the Trigger Selection bits of the Interrupt lines (EXTI\_RTISR and EXTI\_FTSR)
- Configure the enable and mask bits that control the NVIC IRQ channel mapped to the External Interrupt Controller (EXTI) so that an interrupt coming from one of the 20 lines can be correctly acknowledged.

### Hardware event selection

To configure the 20 lines as event sources, use the following procedure:

- Configure the mask bits of the 20 Event lines (EXTI\_EMR)
- Configure the Trigger Selection bits of the Event lines (EXTI\_RTISR and EXTI\_FTSR)

### Software interrupt/event selection

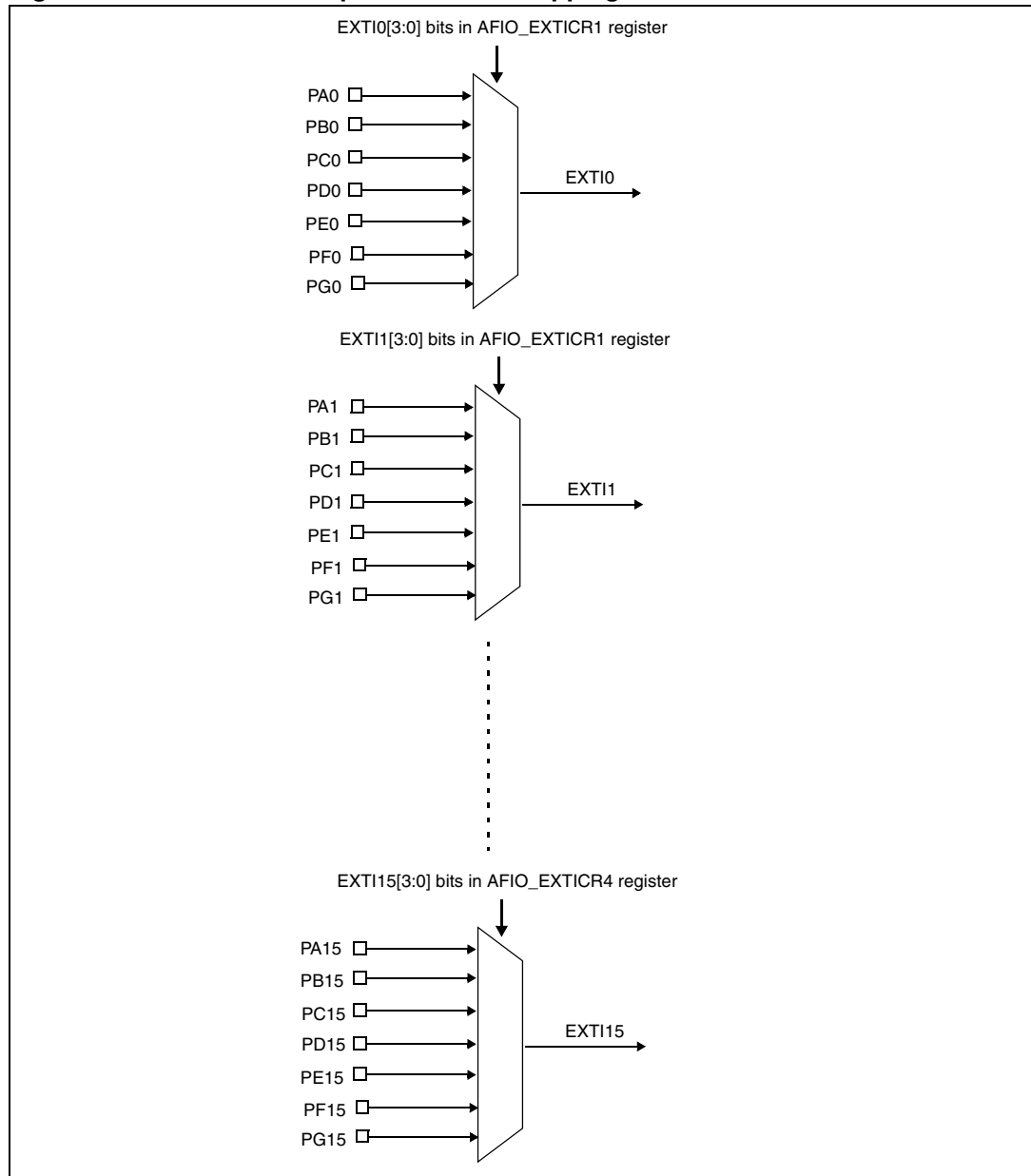
The 20 lines can be configured as software interrupt/event lines. The following is the procedure to generate a software interrupt.

- Configure the mask bits of the 20 Interrupt/Event lines (EXTI\_IMR, EXTI\_EMR)
- Set the required bit of the software interrupt register (EXTI\_SWIER)

## 9.2.5 External interrupt/event line mapping

The 112 GPIOs are connected to the 16 external interrupt/event lines in the following manner:

**Figure 21. External interrupt/event GPIO mapping**



1. To configure the AFIO\_EXTICRx for the mapping of external interrupt/event lines onto GPIOs, the AFIO clock should first be enabled. Refer to [Section 6.3.7: APB2 peripheral clock enable register \(RCC\\_APB2ENR\)](#) for low-, medium-, high- and XL-density devices and, to [Section 7.3.7: APB2 peripheral clock enable register \(RCC\\_APB2ENR\)](#) for connectivity line devices.

The four other EXTI lines are connected as follows:

- EXTI line 16 is connected to the PVD output
- EXTI line 17 is connected to the RTC Alarm event
- EXTI line 18 is connected to the USB Wakeup event
- EXTI line 19 is connected to the Ethernet Wakeup event (available only in connectivity line devices)



### 9.3 EXTI registers

Refer to [Section 1.1 on page 40](#) for a list of abbreviations used in register descriptions.

The peripheral registers have to be accessed by words (32-bit).

#### 9.3.1 Interrupt mask register (EXTI\_IMR)

Address offset: 0x00

Reset value: 0x0000 0000

31	30	29	28	27	26	25	24	23	22	21	20	19	18	17	16
Reserved												MR19	MR18	MR17	MR16
												rw	rw	rw	rw
15	14	13	12	11	10	9	8	7	6	5	4	3	2	1	0
MR15	MR14	MR13	MR12	MR11	MR10	MR9	MR8	MR7	MR6	MR5	MR4	MR3	MR2	MR1	MR0
rw	rw	rw	rw	rw	rw	rw	rw	rw	rw	rw	rw	rw	rw	rw	rw

Bits 31:20 Reserved, must be kept at reset value (0).

Bits 19:0 **MRx**: Interrupt Mask on line x

0: Interrupt request from Line x is masked

1: Interrupt request from Line x is not masked

*Note: Bit 19 is used in connectivity line devices only and is reserved otherwise.*

#### 9.3.2 Event mask register (EXTI\_EMR)

Address offset: 0x04

Reset value: 0x0000 0000

31	30	29	28	27	26	25	24	23	22	21	20	19	18	17	16
Reserved												MR19	MR18	MR17	MR16
												rw	rw	rw	rw
15	14	13	12	11	10	9	8	7	6	5	4	3	2	1	0
MR15	MR14	MR13	MR12	MR11	MR10	MR9	MR8	MR7	MR6	MR5	MR4	MR3	MR2	MR1	MR0
rw	rw	rw	rw	rw	rw	rw	rw	rw	rw	rw	rw	rw	rw	rw	rw

Bits 31:20 Reserved, must be kept at reset value (0).

Bits 19:0 **MRx**: Event mask on line x

0: Event request from Line x is masked

1: Event request from Line x is not masked

*Note: Bit 19 is used in connectivity line devices only and is reserved otherwise.*

### 9.3.3 Rising trigger selection register (EXTI\_RTSR)

Address offset: 0x08  
 Reset value: 0x0000 0000

31	30	29	28	27	26	25	24	23	22	21	20	19	18	17	16
Reserved												TR19	TR18	TR17	TR16
												rw	rw	rw	rw
15	14	13	12	11	10	9	8	7	6	5	4	3	2	1	0
TR15	TR14	TR13	TR12	TR11	TR10	TR9	TR8	TR7	TR6	TR5	TR4	TR3	TR2	TR1	TR0
rw	rw	rw	rw	rw	rw	rw	rw	rw	rw	rw	rw	rw	rw	rw	rw

Bits 31:20 Reserved, must be kept at reset value (0).

Bits 19:0 **TRx**: Rising trigger event configuration bit of line x  
 0: Rising trigger disabled (for Event and Interrupt) for input line  
 1: Rising trigger enabled (for Event and Interrupt) for input line.

*Note: Bit 19 is used in connectivity line devices only and is reserved otherwise.*

*Note: The external wakeup lines are edge triggered, no glitches must be generated on these lines. If a rising edge on external interrupt line occurs during writing of EXTI\_RTISR register, the pending bit will not be set.*

*Rising and Falling edge triggers can be set for the same interrupt line. In this configuration, both generate a trigger condition.*

### 9.3.4 Falling trigger selection register (EXTI\_FTISR)

Address offset: 0x0C  
 Reset value: 0x0000 0000

31	30	29	28	27	26	25	24	23	22	21	20	19	18	17	16
Reserved												TR19	TR18	TR17	TR16
												rw	rw	rw	rw
15	14	13	12	11	10	9	8	7	6	5	4	3	2	1	0
TR15	TR14	TR13	TR12	TR11	TR10	TR9	TR8	TR7	TR6	TR5	TR4	TR3	TR2	TR1	TR0
rw	rw	rw	rw	rw	rw	rw	rw	rw	rw	rw	rw	rw	rw	rw	rw

Bits 31:20 Reserved, must be kept at reset value (0).

Bits 19:0 **TRx**: Falling trigger event configuration bit of line x  
 0: Falling trigger disabled (for Event and Interrupt) for input line  
 1: Falling trigger enabled (for Event and Interrupt) for input line.

*Note: Bit 19 used in connectivity line devices and is reserved otherwise.*

*Note: The external wakeup lines are edge triggered, no glitches must be generated on these lines. If a falling edge on external interrupt line occurs during writing of EXTI\_FTISR register, the pending bit will not be set.*

*Rising and Falling edge triggers can be set for the same interrupt line. In this configuration, both generate a trigger condition.*

### 9.3.5 Software interrupt event register (EXTI\_SWIER)

Address offset: 0x10  
 Reset value: 0x0000 0000

31	30	29	28	27	26	25	24	23	22	21	20	19	18	17	16
Reserved												SWIER 19	SWIER 18	SWIER 17	SWIER 16
												rw	rw	rw	rw
15	14	13	12	11	10	9	8	7	6	5	4	3	2	1	0
SWIER 15	SWIER 14	SWIER 13	SWIER 12	SWIER 11	SWIER 10	SWIER 9	SWIER 8	SWIER 7	SWIER 6	SWIER 5	SWIER 4	SWIER 3	SWIER 2	SWIER 1	SWIER 0
rw	rw	rw	rw	rw	rw	rw	rw	rw	rw	rw	rw	rw	rw	rw	rw

Bits 31:20 Reserved, must be kept at reset value (0).

Bits 19:0 **SWIERx**: Software interrupt on line x

Writing a 1 to this bit when it is at 0 sets the corresponding pending bit in EXTI\_PR. If the interrupt is enabled on this line on the EXTI\_IMR and EXTI\_EMR, an interrupt request is generated.

This bit is cleared by clearing the corresponding bit of EXTI\_PR (by writing a 1 into the bit).

*Note: Bit 19 used in connectivity line devices and is reserved otherwise.*

### 9.3.6 Pending register (EXTI\_PR)

Address offset: 0x14  
 Reset value: undefined

31	30	29	28	27	26	25	24	23	22	21	20	19	18	17	16
Reserved												PR19	PR18	PR17	PR16
												rc_w1	rc_w1	rc_w1	rc_w1
15	14	13	12	11	10	9	8	7	6	5	4	3	2	1	0
PR15	PR14	PR13	PR12	PR11	PR10	PR9	PR8	PR7	PR6	PR5	PR4	PR3	PR2	PR1	PR0
rc_w1	rc_w1	rc_w1	rc_w1	rc_w1	rc_w1	rc_w1	rc_w1	rc_w1	rc_w1	rc_w1	rc_w1	rc_w1	rc_w1	rc_w1	rc_w1

Bits 31:20 Reserved, must be kept at reset value (0).

Bits 19:0 **PRx**: Pending bit

0: No trigger request occurred

1: selected trigger request occurred

This bit is set when the selected edge event arrives on the external interrupt line. This bit is cleared by writing a 1 into the bit or by changing the sensitivity of the edge detector.

*Note: Bit 19 is used in connectivity line devices only and is reserved otherwise.*

### 9.3.7 EXTI register map

The following table gives the EXTI register map and the reset values. Bits 19 in all registers, are used in connectivity line devices and is reserved otherwise.

**Table 62. External interrupt/event controller register map and reset values**

Offset	Register	31	30	29	28	27	26	25	24	23	22	21	20	19	18	17	16	15	14	13	12	11	10	9	8	7	6	5	4	3	2	1	0
0x00	<b>EXTI_IMR</b> Reset value	Reserved													MR[19:0]																		
															0   0																		
0x04	<b>EXTI_EMR</b> Reset value	Reserved													MR[19:0]																		
															0   0																		
0x08	<b>EXTI_RTSR</b> Reset value	Reserved													TR[19:0]																		
															0   0																		
0x0C	<b>EXTI_FTSR</b> Reset value	Reserved													TR[19:0]																		
															0   0																		
0x10	<b>EXTI_SWIER</b> Reset value	Reserved													SWIER[19:0]																		
															0   0																		
0x14	<b>EXTI_PR</b> Reset value	Reserved													PR[19:0]																		
															0   0																		

Refer to [Table 1 on page 44](#) for the register boundary addresses.

## 10 DMA controller (DMA)

**Low-density devices** are STM32F101xx, STM32F102xx and STM32F103xx microcontrollers where the Flash memory density ranges between 16 and 32 Kbytes.

**Medium-density devices** are STM32F101xx, STM32F102xx and STM32F103xx microcontrollers where the Flash memory density ranges between 64 and 128 Kbytes.

**High-density devices** are STM32F101xx and STM32F103xx microcontrollers where the Flash memory density ranges between 256 and 512 Kbytes.

**XL-density devices** are STM32F101xx and STM32F103xx microcontrollers where the Flash memory density ranges between 768 Kbytes and 1 Mbyte.

**Connectivity line devices** are STM32F105xx and STM32F107xx microcontrollers.

This section applies to the whole STM32F10xxx family, unless otherwise specified.

### 10.1 DMA introduction

Direct memory access (DMA) is used in order to provide high-speed data transfer between peripherals and memory as well as memory to memory. Data can be quickly moved by DMA without any CPU actions. This keeps CPU resources free for other operations.

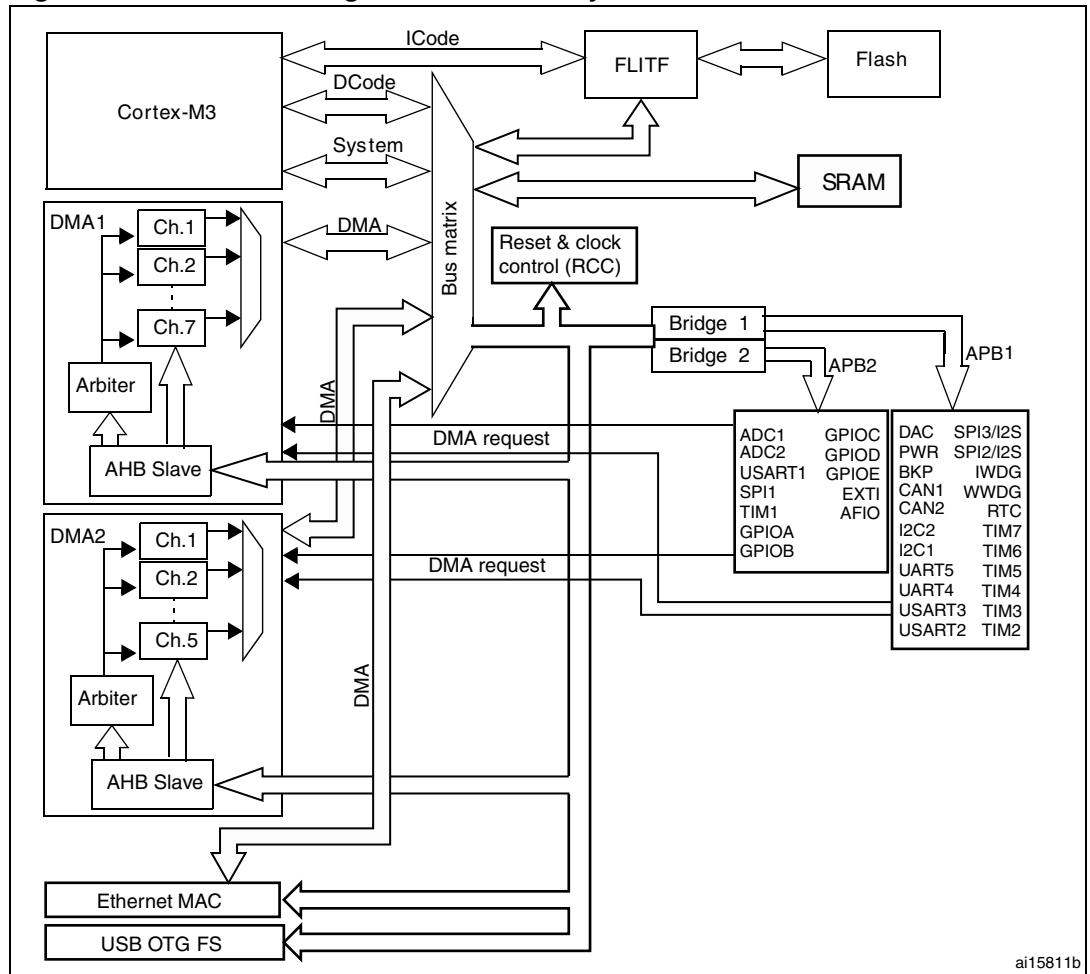
The two DMA controllers have 12 channels in total (7 for DMA1 and 5 for DMA2), each dedicated to managing memory access requests from one or more peripherals. It has an arbiter for handling the priority between DMA requests.

### 10.2 DMA main features

- 12 independently configurable channels (requests): 7 for DMA1 and 5 for DMA2
- Each of the 12 channels is connected to dedicated hardware DMA requests, software trigger is also supported on each channel. This configuration is done by software.
- Priorities between requests from channels of one DMA are software programmable (4 levels consisting of *very high*, *high*, *medium*, *low*) or hardware in case of equality (request 1 has priority over request 2, etc.)
- Independent source and destination transfer size (byte, half word, word), emulating packing and unpacking. Source/destination addresses must be aligned on the data size.
- Support for circular buffer management
- 3 event flags (DMA Half Transfer, DMA Transfer complete and DMA Transfer Error) logically ORed together in a single interrupt request for each channel
- Memory-to-memory transfer
- Peripheral-to-memory and memory-to-peripheral, and peripheral-to-peripheral transfers
- Access to Flash, SRAM, APB1, APB2 and AHB peripherals as source and destination
- Programmable number of data to be transferred: up to 65536

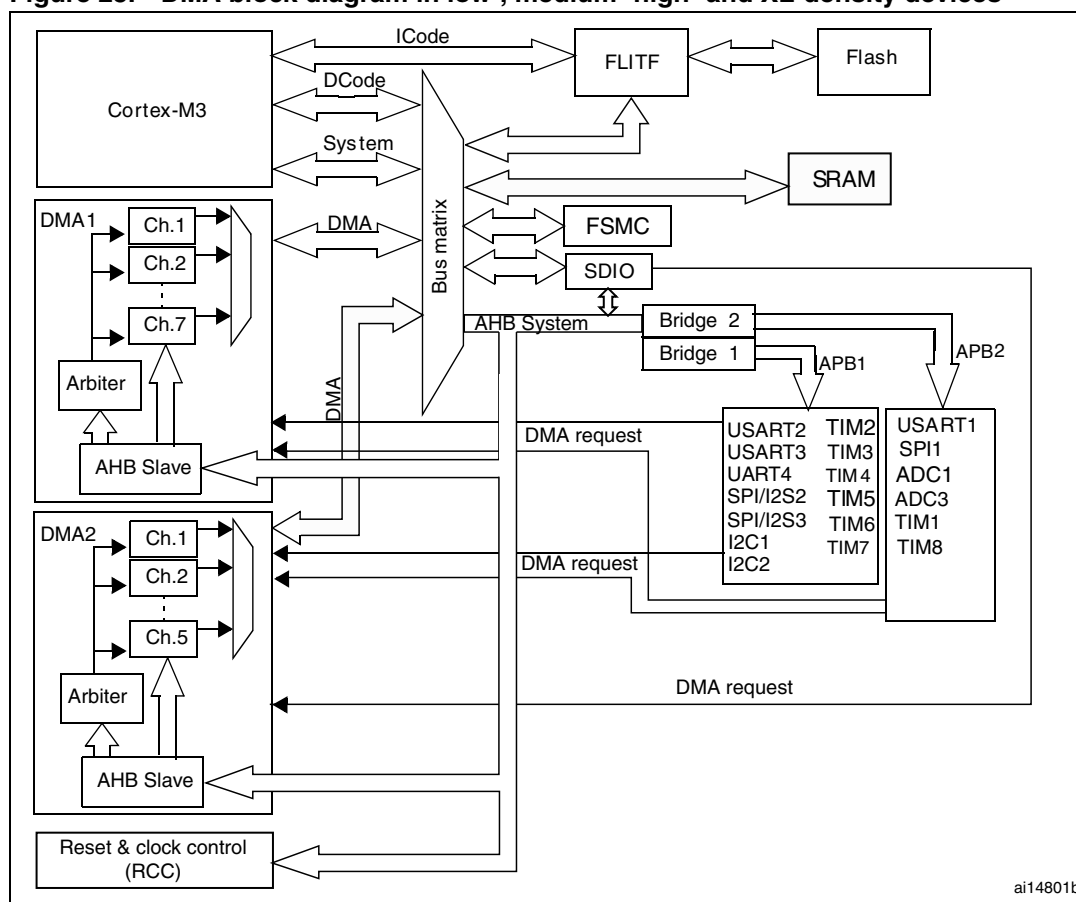
The block diagram is shown in [Figure 22](#).

Figure 22. DMA block diagram in connectivity line devices



ai15811b

Figure 23. DMA block diagram in low-, medium- high- and XL-density devices



1. The DMA2 controller is available only in high-density and XL-density devices.
1. ADC3, SPI/I2S3, UART4, SDIO, TIM5, TIM6, DAC, TIM7, TIM8 DMA requests are available only in high-density devices

### 10.3 DMA functional description

The DMA controller performs direct memory transfer by sharing the system bus with the Cortex™-M3 core. The DMA request may stop the CPU access to the system bus for some bus cycles, when the CPU and DMA are targeting the same destination (memory or peripheral). The bus matrix implements round-robin scheduling, thus ensuring at least half of the system bus bandwidth (both to memory and peripheral) for the CPU.

#### 10.3.1 DMA transactions

After an event, the peripheral sends a request signal to the DMA Controller. The DMA controller serves the request depending on the channel priorities. As soon as the DMA Controller accesses the peripheral, an Acknowledge is sent to the peripheral by the DMA Controller. The peripheral releases its request as soon as it gets the Acknowledge from the DMA Controller. Once the request is deasserted by the peripheral, the DMA Controller release the Acknowledge. If there are more requests, the peripheral can initiate the next transaction.

In summary, each DMA transfer consists of three operations:

- The loading of data from the peripheral data register or a location in memory addressed through an internal current peripheral/memory address register. The start address used for the first transfer is the base peripheral/memory address programmed in the DMA\_CPARx or DMA\_CMARx register
- The storage of the data loaded to the peripheral data register or a location in memory addressed through an internal current peripheral/memory address register. The start address used for the first transfer is the base peripheral/memory address programmed in the DMA\_CPARx or DMA\_CMARx register
- The post-decrementing of the DMA\_CNDTRx register, which contains the number of transactions that have still to be performed.

### 10.3.2 Arbiter

The arbiter manages the channel requests based on their priority and launches the peripheral/memory access sequences.

The priorities are managed in two stages:

- Software: each channel priority can be configured in the DMA\_CCRx register. There are four levels:
  - Very high priority
  - High priority
  - Medium priority
  - Low priority
- Hardware: if 2 requests have the same software priority level, the channel with the lowest number will get priority versus the channel with the highest number. For example, channel 2 gets priority over channel 4.

*Note:* In high-density, XL-density and connectivity line devices, the DMA1 controller has priority over the DMA2 controller.

### 10.3.3 DMA channels

Each channel can handle DMA transfer between a peripheral register located at a fixed address and a memory address. The amount of data to be transferred (up to 65535) is programmable. The register which contains the amount of data items to be transferred is decremented after each transaction.

#### Programmable data sizes

Transfer data sizes of the peripheral and memory are fully programmable through the PSIZE and MSIZE bits in the DMA\_CCRx register.

#### Pointer incrementation

Peripheral and memory pointers can optionally be automatically post-incremented after each transaction depending on the PINC and MINC bits in the DMA\_CCRx register. If incremented mode is enabled, the address of the next transfer will be the address of the previous one incremented by 1, 2 or 4 depending on the chosen data size. The first transfer address is the one programmed in the DMA\_CPARx/DMA\_CMARx registers. During transfer operations, these registers keep the initially programmed value. The current transfer



addresses (in the current internal peripheral/memory address register) are not accessible by software.

If the channel is configured in noncircular mode, no DMA request is served after the last transfer (that is once the number of data items to be transferred has reached zero). In order to reload a new number of data items to be transferred into the DMA\_CNDTRx register, the DMA channel must be disabled.

*Note: If a DMA channel is disabled, the DMA registers are not reset. The DMA channel registers (DMA\_CCRx, DMA\_CPARx and DMA\_CMARx) retain the initial values programmed during the channel configuration phase.*

In circular mode, after the last transfer, the DMA\_CNDTRx register is automatically reloaded with the initially programmed value. The current internal address registers are reloaded with the base address values from the DMA\_CPARx/DMA\_CMARx registers.

### Channel configuration procedure

The following sequence should be followed to configure a DMA channelx (where x is the channel number).

1. Set the peripheral register address in the DMA\_CPARx register. The data will be moved from/ to this address to/ from the memory after the peripheral event.
2. Set the memory address in the DMA\_CMARx register. The data will be written to or read from this memory after the peripheral event.
3. Configure the total number of data to be transferred in the DMA\_CNDTRx register. After each peripheral event, this value will be decremented.
4. Configure the channel priority using the PL[1:0] bits in the DMA\_CCRx register
5. Configure data transfer direction, circular mode, peripheral & memory incremented mode, peripheral & memory data size, and interrupt after half and/or full transfer in the DMA\_CCRx register
6. Activate the channel by setting the ENABLE bit in the DMA\_CCRx register.

As soon as the channel is enabled, it can serve any DMA request from the peripheral connected on the channel.

Once half of the bytes are transferred, the half-transfer flag (HTIF) is set and an interrupt is generated if the Half-Transfer Interrupt Enable bit (HTIE) is set. At the end of the transfer, the Transfer Complete Flag (TCIF) is set and an interrupt is generated if the Transfer Complete Interrupt Enable bit (TCIE) is set.

### Circular mode

Circular mode is available to handle circular buffers and continuous data flows (e.g. ADC scan mode). This feature can be enabled using the CIRC bit in the DMA\_CCRx register. When circular mode is activated, the number of data to be transferred is automatically reloaded with the initial value programmed during the channel configuration phase, and the DMA requests continue to be served.

### Memory-to-memory mode

The DMA channels can also work without being triggered by a request from a peripheral. This mode is called Memory to Memory mode.

If the MEM2MEM bit in the DMA\_CCRx register is set, then the channel initiates transfers as soon as it is enabled by software by setting the Enable bit (EN) in the DMA\_CCRx register.

The transfer stops once the DMA\_CNDTRx register reaches zero. Memory to Memory mode may not be used at the same time as Circular mode.

### 10.3.4 Programmable data width, data alignment and endians

When PSIZE and MSIZE are not equal, the DMA performs some data alignments as described in [Table 63: Programmable data width & endian behavior \(when bits PINC = MINC = 1\)](#).

**Table 63. Programmable data width & endian behavior (when bits PINC = MINC = 1)**

Source port width	Destination port width	Number of data items to transfer (NDT)	Source content: address / data	Transfer operations	Destination content: address / data
8	8	4	@0x0 / B0 @0x1 / B1 @0x2 / B2 @0x3 / B3	1: READ B0[7:0] @0x0 then WRITE B0[7:0] @0x0 2: READ B1[7:0] @0x1 then WRITE B1[7:0] @0x1 3: READ B2[7:0] @0x2 then WRITE B2[7:0] @0x2 4: READ B3[7:0] @0x3 then WRITE B3[7:0] @0x3	@0x0 / B0 @0x1 / B1 @0x2 / B2 @0x3 / B3
8	16	4	@0x0 / B0 @0x1 / B1 @0x2 / B2 @0x3 / B3	1: READ B0[7:0] @0x0 then WRITE 00B0[15:0] @0x0 2: READ B1[7:0] @0x1 then WRITE 00B1[15:0] @0x2 3: READ B3[7:0] @0x2 then WRITE 00B2[15:0] @0x4 4: READ B4[7:0] @0x3 then WRITE 00B3[15:0] @0x6	@0x0 / 00B0 @0x2 / 00B1 @0x4 / 00B2 @0x6 / 00B3
8	32	4	@0x0 / B0 @0x1 / B1 @0x2 / B2 @0x3 / B3	1: READ B0[7:0] @0x0 then WRITE 000000B0[31:0] @0x0 2: READ B1[7:0] @0x1 then WRITE 000000B1[31:0] @0x4 3: READ B3[7:0] @0x2 then WRITE 000000B2[31:0] @0x8 4: READ B4[7:0] @0x3 then WRITE 000000B3[31:0] @0xC	@0x0 / 000000B0 @0x4 / 000000B1 @0x8 / 000000B2 @0xC / 000000B3
16	8	4	@0x0 / B1B0 @0x2 / B3B2 @0x4 / B5B4 @0x6 / B7B6	1: READ B1B0[15:0] @0x0 then WRITE B0[7:0] @0x0 2: READ B3B2[15:0] @0x2 then WRITE B2[7:0] @0x1 3: READ B5B4[15:0] @0x4 then WRITE B4[7:0] @0x2 4: READ B7B6[15:0] @0x6 then WRITE B6[7:0] @0x3	@0x0 / B0 @0x1 / B2 @0x2 / B4 @0x3 / B6
16	16	4	@0x0 / B1B0 @0x2 / B3B2 @0x4 / B5B4 @0x6 / B7B6	1: READ B1B0[15:0] @0x0 then WRITE B1B0[15:0] @0x0 2: READ B3B2[15:0] @0x2 then WRITE B3B2[15:0] @0x2 3: READ B5B4[15:0] @0x4 then WRITE B5B4[15:0] @0x4 4: READ B7B6[15:0] @0x6 then WRITE B7B6[15:0] @0x6	@0x0 / B1B0 @0x2 / B3B2 @0x4 / B5B4 @0x6 / B7B6
16	32	4	@0x0 / B1B0 @0x2 / B3B2 @0x4 / B5B4 @0x6 / B7B6	1: READ B1B0[15:0] @0x0 then WRITE 0000B1B0[31:0] @0x0 2: READ B3B2[15:0] @0x2 then WRITE 0000B3B2[31:0] @0x4 3: READ B5B4[15:0] @0x4 then WRITE 0000B5B4[31:0] @0x8 4: READ B7B6[15:0] @0x6 then WRITE 0000B7B6[31:0] @0xC	@0x0 / 0000B1B0 @0x4 / 0000B3B2 @0x8 / 0000B5B4 @0xC / 0000B7B6
32	8	4	@0x0 / B3B2B1B0 @0x4 / B7B6B5B4 @0x8 / BBBAB9B8 @0xC / BFBEBDBC	1: READ B3B2B1B0[31:0] @0x0 then WRITE B0[7:0] @0x0 2: READ B7B6B5B4[31:0] @0x4 then WRITE B4[7:0] @0x1 3: READ BBBAB9B8[31:0] @0x8 then WRITE B8[7:0] @0x2 4: READ BFBEBDBC[31:0] @0xC then WRITE BC[7:0] @0x3	@0x0 / B0 @0x1 / B4 @0x2 / B8 @0x3 / BC
32	16	4	@0x0 / B3B2B1B0 @0x4 / B7B6B5B4 @0x8 / BBBAB9B8 @0xC / BFBEBDBC	1: READ B3B2B1B0[31:0] @0x0 then WRITE B1B0[7:0] @0x0 2: READ B7B6B5B4[31:0] @0x4 then WRITE B5B4[7:0] @0x1 3: READ BBBAB9B8[31:0] @0x8 then WRITE B9B8[7:0] @0x2 4: READ BFBEBDBC[31:0] @0xC then WRITE BDBC[7:0] @0x3	@0x0 / B1B0 @0x2 / B5B4 @0x4 / B9B8 @0x6 / BDBC
32	32	4	@0x0 / B3B2B1B0 @0x4 / B7B6B5B4 @0x8 / BBBAB9B8 @0xC / BFBEBDBC	1: READ B3B2B1B0[31:0] @0x0 then WRITE B3B2B1B0[31:0] @0x0 2: READ B7B6B5B4[31:0] @0x4 then WRITE B7B6B5B4[31:0] @0x4 3: READ BBBAB9B8[31:0] @0x8 then WRITE BBBAB9B8[31:0] @0x8 4: READ BFBEBDBC[31:0] @0xC then WRITE BFBEBDBC[31:0] @0xC	@0x0 / B3B2B1B0 @0x4 / B7B6B5B4 @0x8 / BBBAB9B8 @0xC / BFBEBDBC

#### Addressing an AHB peripheral that does not support byte or halfword write operations

When the DMA initiates an AHB byte or halfword write operation, the data are duplicated on the unused lanes of the HWDATA[31:0] bus. So when the used AHB slave peripheral does not support byte or halfword write operations (when HSIZE is not used by the peripheral)



and does not generate any error, the DMA writes the 32 HWDATA bits as shown in the two examples below:

- To write the halfword “0xABCD”, the DMA sets the HWDATA bus to “0xABCDABCD” with HSIZE = HalfWord
- To write the byte “0xAB”, the DMA sets the HWDATA bus to “0xABABABAB” with HSIZE = Byte

Assuming that the AHB/APB bridge is an AHB 32-bit slave peripheral that does not take the HSIZE data into account, it will transform any AHB byte or halfword operation into a 32-bit APB operation in the following manner:

- an AHB byte write operation of the data “0xB0” to 0x0 (or to 0x1, 0x2 or 0x3) will be converted to an APB word write operation of the data “0xB0B0B0B0” to 0x0
- an AHB halfword write operation of the data “0xB1B0” to 0x0 (or to 0x2) will be converted to an APB word write operation of the data “0xB1B0B1B0” to 0x0

For instance, if you want to write the APB backup registers (16-bit registers aligned to a 32-bit address boundary), you must configure the memory source size (MSIZE) to “16-bit” and the peripheral destination size (PSIZE) to “32-bit”.

### 10.3.5 Error management

A DMA transfer error can be generated by reading from or writing to a reserved address space. When a DMA transfer error occurs during a DMA read or a write access, the faulty channel is automatically disabled through a hardware clear of its EN bit in the corresponding Channel configuration register (DMA\_CCRx). The channel's transfer error interrupt flag (TEIF) in the DMA\_IFR register is set and an interrupt is generated if the transfer error interrupt enable bit (TEIE) in the DMA\_CCRx register is set.

### 10.3.6 Interrupts

An interrupt can be produced on a Half-transfer, Transfer complete or Transfer error for each DMA channel. Separate interrupt enable bits are available for flexibility.

**Table 64. DMA interrupt requests**

Interrupt event	Event flag	Enable Control bit
Half-transfer	HTIF	HTIE
Transfer complete	TCIF	TCIE
Transfer error	TEIF	TEIE

*Note:* In high-density and XL-density devices, DMA2 Channel4 and DMA2 Channel5 interrupts are mapped onto the same interrupt vector. In connectivity line devices, DMA2 Channel4 and DMA2 Channel5 interrupts have separate interrupt vectors. All other DMA1 and DMA2 Channel interrupts have their own interrupt vector.

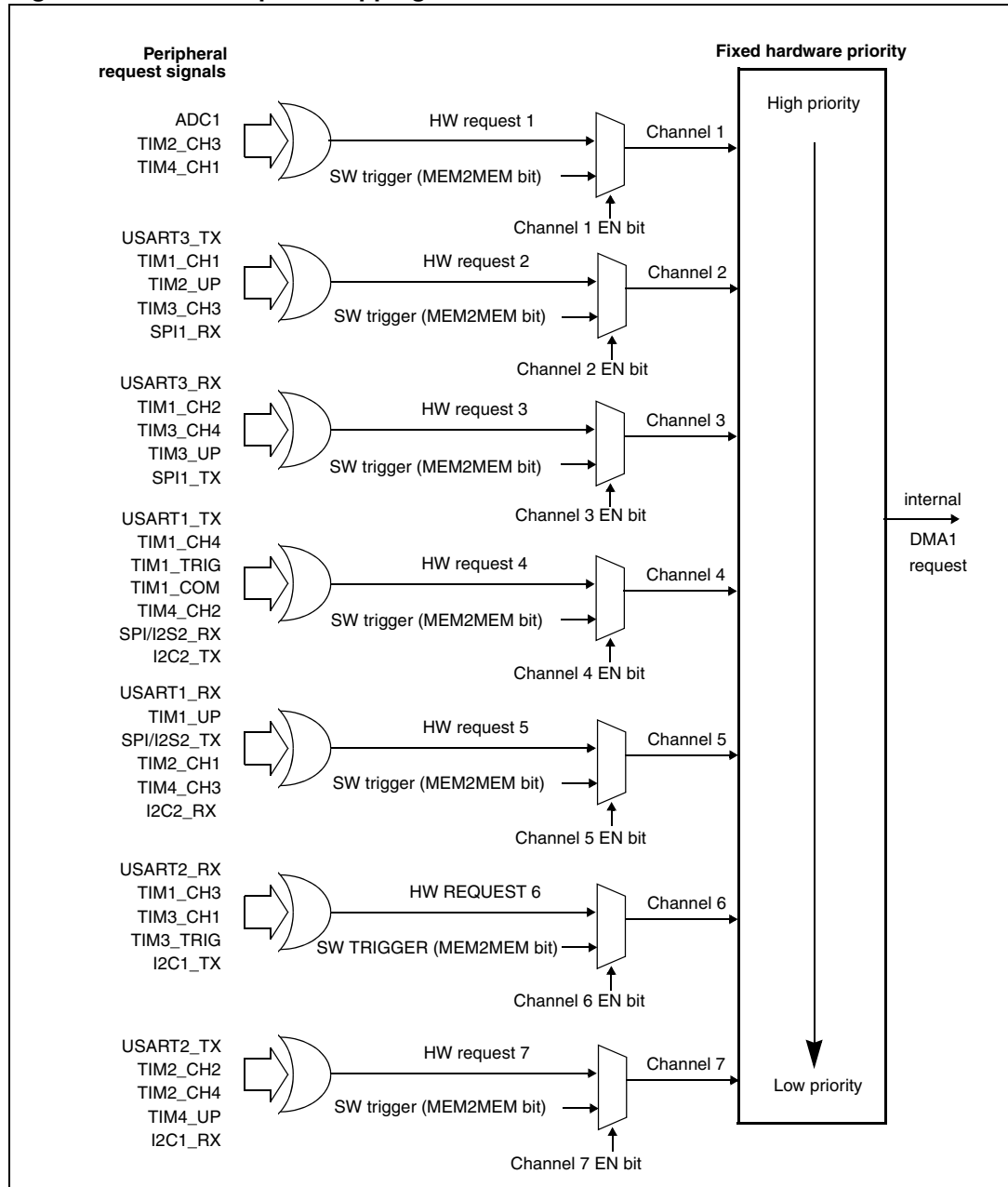
### 10.3.7 DMA request mapping

#### DMA1 controller

The 7 requests from the peripherals (TIMx[1,2,3,4], ADC1, SPI1, SPI/I2S2, I2Cx[1,2] and USARTx[1,2,3]) are simply logically ORed before entering the DMA1, this means that only one request must be enabled at a time. Refer to *Figure 24: DMA1 request mapping*.

The peripheral DMA requests can be independently activated/de-activated by programming the DMA control bit in the registers of the corresponding peripheral.

**Figure 24. DMA1 request mapping**



*Table 65* lists the DMA requests for each channel.

Table 65. Summary of DMA1 requests for each channel

Peripherals	Channel 1	Channel 2	Channel 3	Channel 4	Channel 5	Channel 6	Channel 7
ADC1	ADC1						
SPI/I <sup>2</sup> S		SPI1_RX	SPI1_TX	SPI2/I2S2_RX	SPI2/I2S2_TX		
USART		USART3_TX	USART3_RX	USART1_TX	USART1_RX	USART2_RX	USART2_TX
I <sup>2</sup> C				I2C2_TX	I2C2_RX	I2C1_TX	I2C1_RX
TIM1		TIM1_CH1	TIM1_CH2	TIM1_CH4 TIM1_TRIG TIM1_COM	TIM1_UP	TIM1_CH3	
TIM2	TIM2_CH3	TIM2_UP			TIM2_CH1		TIM2_CH2 TIM2_CH4
TIM3		TIM3_CH3	TIM3_CH4 TIM3_UP			TIM3_CH1 TIM3_TRIG	
TIM4	TIM4_CH1			TIM4_CH2	TIM4_CH3		TIM4_UP

### DMA2 controller

The 5 requests from the peripherals (TIMx[5,6,7,8], ADC3, SPI/I2S3, UART4, DAC\_Channel[1,2]and SDIO) are simply logically ORed before entering the DMA2, this means that only one request must be enabled at a time. Refer to [Figure 25: DMA2 request mapping](#).

The peripheral DMA requests can be independently activated/de-activated by programming the DMA control bit in the registers of the corresponding peripheral.

*Note:* The DMA2 controller and its relative requests are available only in high-density, XL-density and connectivity line devices.

Figure 25. DMA2 request mapping

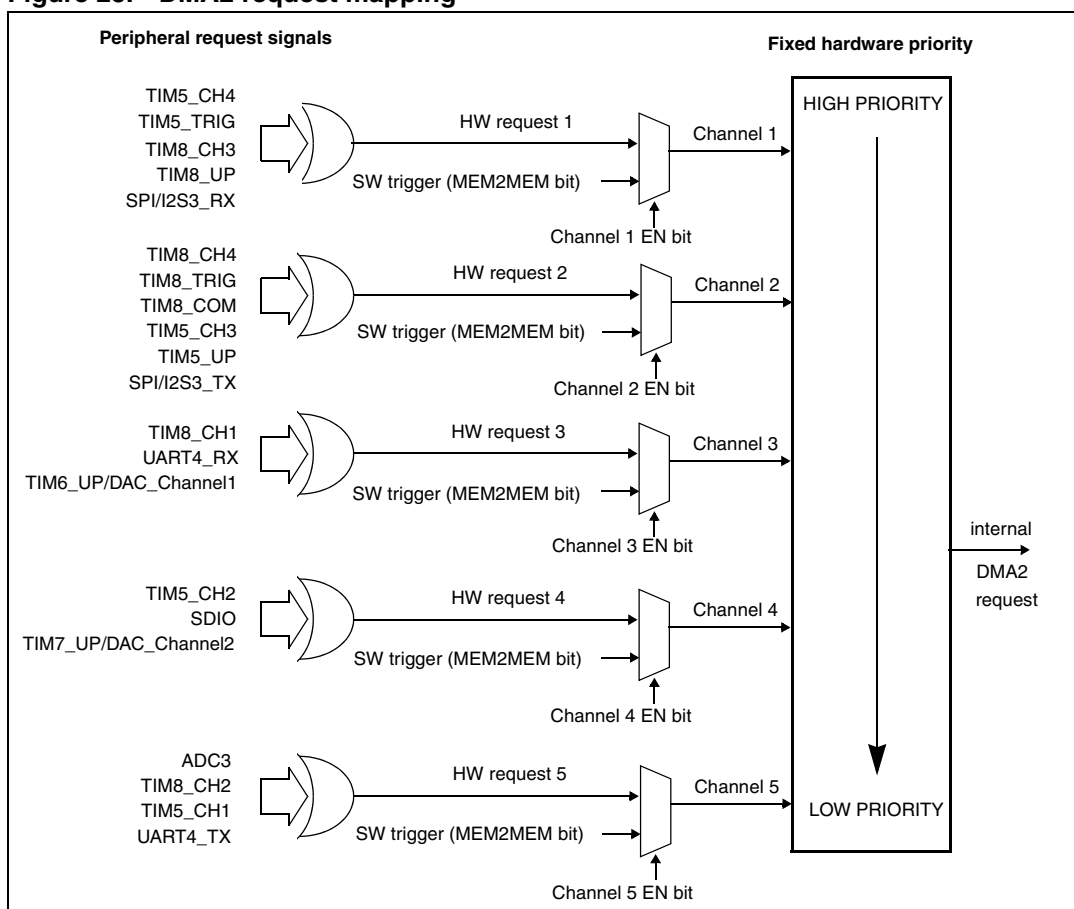


Table 66 lists the DMA2 requests for each channel.

Table 66. Summary of DMA2 requests for each channel

Peripherals	Channel 1	Channel 2	Channel 3	Channel 4	Channel 5
ADC3 <sup>(1)</sup>					ADC3
SPI/I2S3	SPI/I2S3_RX	SPI/I2S3_TX			
UART4			UART4_RX		UART4_TX
SDIO <sup>(1)</sup>				SDIO	
TIM5	TIM5_CH4 TIM5_TRIG	TIM5_CH3 TIM5_UP		TIM5_CH2	TIM5_CH1
TIM6/ DAC_Channel1			TIM6_UP/ DAC_Channel1		
TIM7/ DAC_Channel2				TIM7_UP/ DAC_Channel2	
TIM8 <sup>(1)</sup>	TIM8_CH3 TIM8_UP	TIM8_CH4 TIM8_TRIG TIM8_COM	TIM8_CH1		TIM8_CH2

1. ADC3, SDIO and TIM8 DMA requests are available only in high-density and XL-density devices.

## 10.4 DMA registers

Refer to [Section 1.1 on page 40](#) for a list of abbreviations used in the register descriptions.

*Note:* In the following registers, all bits relative to channel6 and channel7 are not relevant for DMA2 since it has only 5 channels.

The peripheral registers can be accessed by bytes (8-bit), half-words (16-bit) or words (32-bit).

### 10.4.1 DMA interrupt status register (DMA\_ISR)

Address offset: 0x00

Reset value: 0x0000 0000

31	30	29	28	27	26	25	24	23	22	21	20	19	18	17	16
Reserved				TEIF7	HTIF7	TCIF7	GIF7	TEIF6	HTIF6	TCIF6	GIF6	TEIF5	HTIF5	TCIF5	GIF5
				r	r	r	r	r	r	r	r	r	r	r	r
15	14	13	12	11	10	9	8	7	6	5	4	3	2	1	0
TEIF4	HTIF4	TCIF4	GIF4	TEIF3	HTIF3	TCIF3	GIF3	TEIF2	HTIF2	TCIF2	GIF2	TEIF1	HTIF1	TCIF1	GIF1
r	r	r	r	r	r	r	r	r	r	r	r	r	r	r	r

Bits 31:28 Reserved, always read as 0.

Bits 27, 23, 19, 15, 11, 7, 3 **TEIFx**: Channel x transfer error flag (x = 1 ..7)  
 This bit is set by hardware. It is cleared by software writing 1 to the corresponding bit in the DMA\_IFCR register.  
 0: No transfer error (TE) on channel x  
 1: A transfer error (TE) occurred on channel x

Bits 26, 22, 18, 14, 10, 6, 2 **HTIFx**: Channel x half transfer flag (x = 1 ..7)  
 This bit is set by hardware. It is cleared by software writing 1 to the corresponding bit in the DMA\_IFCR register.  
 0: No half transfer (HT) event on channel x  
 1: A half transfer (HT) event occurred on channel x

Bits 25, 21, 17, 13, 9, 5, 1 **TCIFx**: Channel x transfer complete flag (x = 1 ..7)  
 This bit is set by hardware. It is cleared by software writing 1 to the corresponding bit in the DMA\_IFCR register.  
 0: No transfer complete (TC) event on channel x  
 1: A transfer complete (TC) event occurred on channel x

Bits 24, 20, 16, 12, 8, 4, 0 **GIFx**: Channel x global interrupt flag (x = 1 ..7)  
 This bit is set by hardware. It is cleared by software writing 1 to the corresponding bit in the DMA\_IFCR register.  
 0: No TE, HT or TC event on channel x  
 1: A TE, HT or TC event occurred on channel x

### 10.4.2 DMA interrupt flag clear register (DMA\_IFCR)

Address offset: 0x04

Reset value: 0x0000 0000

31				30				29				28				27				26				25				24				23				22				21				20				19				18				17				16			
Reserved																CTEIF7	CHTIF7	CTCIF7	CGIF7	CTEIF6	CHTIF6	CTCIF6	CGIF6	CTEIF5	CHTIF5	CTCIF5	CGIF5																																				
																w	w	w	w	w	w	w	w	w	w	w	w																																				
15				14				13				12				11				10				9				8				7				6				5				4				3				2				1				0			
CTEIF4	CHTIF4	CTCIF4	CGIF4	CTEIF3	CHTIF3	CTCIF3	CGIF3	CTEIF2	CHTIF2	CTCIF2	CGIF2	CTEIF1	CHTIF1	CTCIF1	CGIF1																																																
w	w	w	w	w	w	w	w	w	w	w	w	w	w	w	w																																																

Bits 31:28 Reserved, always read as 0.

Bits 27, 23, 19, 15, **CTEIFx**: Channel x transfer error clear (x = 1 ..7)

11, 7, 3 This bit is set and cleared by software.

0: No effect

1: Clears the corresponding TEIF flag in the DMA\_ISR register

Bits 26, 22, 18, 14, **CHTIFx**: Channel x half transfer clear (x = 1 ..7)

10, 6, 2 This bit is set and cleared by software.

0: No effect

1: Clears the corresponding HTIF flag in the DMA\_ISR register

Bits 25, 21, 17, 13, **CTCIFx**: Channel x transfer complete clear (x = 1 ..7)

9, 5, 1 This bit is set and cleared by software.

0: No effect

1: Clears the corresponding TCIF flag in the DMA\_ISR register

Bits 24, 20, 16, 12, **CGIFx**: Channel x global interrupt clear (x = 1 ..7)

8, 4, 0 This bit is set and cleared by software.

0: No effect

1: Clears the GIF, TEIF, HTIF and TCIF flags in the DMA\_ISR register



### 10.4.3 DMA channel x configuration register (DMA\_CCRx) (x = 1..7, where x = channel number)

Address offset: 0x08 + 0d20 × (channel number – 1)

Reset value: 0x0000 0000

31	30	29	28	27	26	25	24	23	22	21	20	19	18	17	16
Reserved															
15	14	13	12	11	10	9	8	7	6	5	4	3	2	1	0
Res.	MEM2 MEM	PL[1:0]		MSIZE[1:0]		PSIZE[1:0]		MINC	PINC	CIRC	DIR	TEIE	HTIE	TCIE	EN
	rw	rw	rw	rw	rw	rw	rw	rw	rw	rw	rw	rw	rw	rw	rw

Bits 31:15 Reserved, always read as 0.

Bit 14 **MEM2MEM**: Memory to memory mode  
 This bit is set and cleared by software.  
 0: Memory to memory mode disabled  
 1: Memory to memory mode enabled

Bits 13:12 **PL[1:0]**: Channel priority level  
 These bits are set and cleared by software.  
 00: Low  
 01: Medium  
 10: High  
 11: Very high

Bits 11:10 **MSIZE[1:0]**: Memory size  
 These bits are set and cleared by software.  
 00: 8-bits  
 01: 16-bits  
 10: 32-bits  
 11: Reserved

Bits 9:8 **PSIZE[1:0]**: Peripheral size  
 These bits are set and cleared by software.  
 00: 8-bits  
 01: 16-bits  
 10: 32-bits  
 11: Reserved

Bit 7 **MINC**: Memory increment mode  
 This bit is set and cleared by software.  
 0: Memory increment mode disabled  
 1: Memory increment mode enabled

Bit 6 **PINC**: Peripheral increment mode  
 This bit is set and cleared by software.  
 0: Peripheral increment mode disabled  
 1: Peripheral increment mode enabled

Bit 5 **CIRC**: Circular mode  
 This bit is set and cleared by software.  
 0: Circular mode disabled  
 1: Circular mode enabled

- Bit 4 **DIR**: Data transfer direction  
 This bit is set and cleared by software.  
 0: Read from peripheral  
 1: Read from memory
- Bit 3 **TEIE**: Transfer error interrupt enable  
 This bit is set and cleared by software.  
 0: TE interrupt disabled  
 1: TE interrupt enabled
- Bit 2 **HTIE**: Half transfer interrupt enable  
 This bit is set and cleared by software.  
 0: HT interrupt disabled  
 1: HT interrupt enabled
- Bit 1 **TCIE**: Transfer complete interrupt enable  
 This bit is set and cleared by software.  
 0: TC interrupt disabled  
 1: TC interrupt enabled
- Bit 0 **EN**: Channel enable  
 This bit is set and cleared by software.  
 0: Channel disabled  
 1: Channel enabled

#### 10.4.4 DMA channel x number of data register (DMA\_CNDTRx) (x = 1..7), where x = channel number

Address offset: 0x0C + 0d20 × (channel number – 1)

Reset value: 0x0000 0000

31	30	29	28	27	26	25	24	23	22	21	20	19	18	17	16
Reserved															
15	14	13	12	11	10	9	8	7	6	5	4	3	2	1	0
NDT															
rw	rw	rw	rw	rw	rw	rw	rw	rw	rw	rw	rw	rw	rw	rw	rw

Bits 31:16 Reserved, always read as 0.

Bits 15:0 **NDT[15:0]**: Number of data to transfer

Number of data to be transferred (0 up to 65535). This register can only be written when the channel is disabled. Once the channel is enabled, this register is read-only, indicating the remaining bytes to be transmitted. This register decrements after each DMA transfer.

Once the transfer is completed, this register can either stay at zero or be reloaded automatically by the value previously programmed if the channel is configured in auto-reload mode.

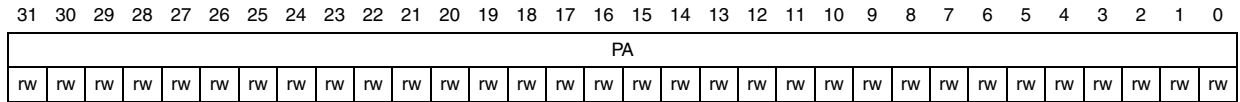
If this register is zero, no transaction can be served whether the channel is enabled or not.

**10.4.5 DMA channel x peripheral address register (DMA\_CPARx) (x = 1..7), where x = channel number)**

Address offset:  $0x10 + 0d20 \times (\text{channel number} - 1)$

Reset value: 0x0000 0000

This register must *not* be written when the channel is enabled.



Bits 31:0 **PA[31:0]**: Peripheral address

Base address of the peripheral data register from/to which the data will be read/written.

When PSIZE is 01 (16-bit), the PA[0] bit is ignored. Access is automatically aligned to a half-word address.

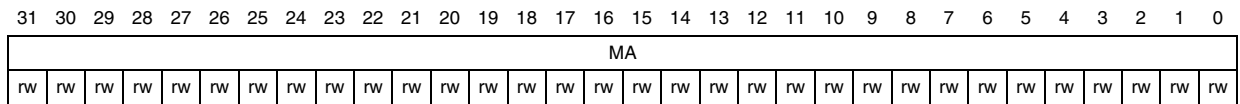
When PSIZE is 10 (32-bit), PA[1:0] are ignored. Access is automatically aligned to a word address.

**10.4.6 DMA channel x memory address register (DMA\_CMARx) (x = 1..7), where x = channel number)**

Address offset:  $0x14 + 0d20 \times (\text{channel number} - 1)$

Reset value: 0x0000 0000

This register must *not* be written when the channel is enabled.



Bits 31:0 **MA[31:0]**: Memory address

Base address of the memory area from/to which the data will be read/written.

When MSIZE is 01 (16-bit), the MA[0] bit is ignored. Access is automatically aligned to a half-word address.

When MSIZE is 10 (32-bit), MA[1:0] are ignored. Access is automatically aligned to a word address.

### 10.4.7 DMA register map

The following table gives the DMA register map and the reset values.

**Table 67. DMA register map and reset values**

Offset	Register	31	30	29	28	27	26	25	24	23	22	21	20	19	18	17	16	15	14	13	12	11	10	9	8	7	6	5	4	3	2	1	0															
0x000	DMA_ISR	Reserved					TEIF7	HTIF7	TCIF7	GIF7	TEIF6	HTIF6	TCIF6	GIF6	TEIF5	HTIF5	TCIF5	GIF5	TEIF4	HTIF4	TCIF4	GIF4	TEIF3	HTIF3	TCIF3	GIF3	TEIF2	HTIF2	TCIF2	GIF2	TEIF1	HTIF1	TCIF1	GIF1														
	Reset value						0	0	0	0	0	0	0	0	0	0	0	0	0	0	0	0	0	0	0	0	0	0	0	0	0	0	0	0														
0x004	DMA_IFCR	Reserved					CTEIF7	CHTIF7	CTCIF7	CGIF7	CTEIF6	CHTIF6	CTCIF6	CGIF6	CTEIF5	CHTIF5	CTCIF5	CGIF5	CTEIF4	CHTIF4	CTCIF4	CGIF4	CTEIF3	CHTIF3	CTCIF3	CGIF3	CTEIF2	CHTIF2	CTCIF2	CGIF2	CTEIF1	CHTIF1	CTCIF1	CGIF1														
	Reset value						0	0	0	0	0	0	0	0	0	0	0	0	0	0	0	0	0	0	0	0	0	0	0	0	0	0	0	0														
0x008	DMA_CCR1	Reserved																	MEM2MEM	PL [1:0]	M SIZE [1:0]	PSIZE [1:0]	MINC	PINC	CIRC	DIR	TEIE	HTIE	TCIE	EN																		
	Reset value																		0	0	0	0	0	0	0	0	0	0	0	0	0	0	0	0	0	0	0	0	0	0	0	0						
0x00C	DMA_CNDTR1	Reserved																	NDT[15:0]																													
	Reset value																		0	0	0	0	0	0	0	0	0	0	0	0	0	0	0	0	0	0	0	0	0	0	0	0	0	0	0	0	0	0
0x010	DMA_CPAR1	PA[31:0]																																														
	Reset value	0	0	0	0	0	0	0	0	0	0	0	0	0	0	0	0	0	0	0	0	0	0	0	0	0	0	0	0	0	0	0	0	0	0													
0x014	DMA_CMAR1	MA[31:0]																																														
	Reset value	0	0	0	0	0	0	0	0	0	0	0	0	0	0	0	0	0	0	0	0	0	0	0	0	0	0	0	0	0	0	0	0	0	0													
0x018	Reserved																																															
0x01C	DMA_CCR2	Reserved																	MEM2MEM	PL [1:0]	M SIZE [1:0]	PSIZE [1:0]	MINC	PINC	CIRC	DIR	TEIE	HTIE	TCIE	EN																		
	Reset value																		0	0	0	0	0	0	0	0	0	0	0	0	0	0	0	0	0	0	0	0	0	0	0							
0x020	DMA_CNDTR2	Reserved																	NDT[15:0]																													
	Reset value																		0	0	0	0	0	0	0	0	0	0	0	0	0	0	0	0	0	0	0	0	0	0	0	0	0	0	0	0	0	0
0x024	DMA_CPAR2	PA[31:0]																																														
	Reset value	0	0	0	0	0	0	0	0	0	0	0	0	0	0	0	0	0	0	0	0	0	0	0	0	0	0	0	0	0	0	0	0	0	0													
0x028	DMA_CMAR2	MA[31:0]																																														
	Reset value	0	0	0	0	0	0	0	0	0	0	0	0	0	0	0	0	0	0	0	0	0	0	0	0	0	0	0	0	0	0	0	0	0	0													
0x02C	Reserved																																															
0x030	DMA_CCR3	Reserved																	MEM2MEM	PL [1:0]	M SIZE [1:0]	PSIZE [1:0]	MINC	PINC	CIRC	DIR	TEIE	HTIE	TCIE	EN																		
	Reset value																		0	0	0	0	0	0	0	0	0	0	0	0	0	0	0	0	0	0	0	0	0	0	0							
0x034	DMA_CNDTR3	Reserved																	NDT[15:0]																													
	Reset value																		0	0	0	0	0	0	0	0	0	0	0	0	0	0	0	0	0	0	0	0	0	0	0	0	0	0	0	0	0	0
0x038	DMA_CPAR3	PA[31:0]																																														
	Reset value	0	0	0	0	0	0	0	0	0	0	0	0	0	0	0	0	0	0	0	0	0	0	0	0	0	0	0	0	0	0	0	0	0	0													
0x03C	DMA_CMAR3	MA[31:0]																																														
	Reset value	0	0	0	0	0	0	0	0	0	0	0	0	0	0	0	0	0	0	0	0	0	0	0	0	0	0	0	0	0	0	0	0	0	0													
0x040	Reserved																																															
0x044	DMA_CCR4	Reserved																	MEM2MEM	PL [1:0]	M SIZE [1:0]	PSIZE [1:0]	MINC	PINC	CIRC	DIR	TEIE	HTIE	TCIE	EN																		
	Reset value																		0	0	0	0	0	0	0	0	0	0	0	0	0	0	0	0	0	0	0	0	0	0	0							
0x048	DMA_CNDTR4	Reserved																	NDT[15:0]																													
	Reset value																		0	0	0	0	0	0	0	0	0	0	0	0	0	0	0	0	0	0	0	0	0	0	0	0	0	0	0	0	0	0



Table 67. DMA register map and reset values (continued)

Offset	Register	31	30	29	28	27	26	25	24	23	22	21	20	19	18	17	16	15	14	13	12	11	10	9	8	7	6	5	4	3	2	1	0					
0x04C	DMA_CPAR4	PA[31:0]																																				
	Reset value	0	0	0	0	0	0	0	0	0	0	0	0	0	0	0	0	0	0	0	0	0	0	0	0	0	0	0	0	0	0	0	0	0	0			
0x050	DMA_CMAR4	MA[31:0]																																				
	Reset value	0	0	0	0	0	0	0	0	0	0	0	0	0	0	0	0	0	0	0	0	0	0	0	0	0	0	0	0	0	0	0	0	0	0			
0x054	Reserved																																					
0x058	DMA_CCR5	Reserved															MEM2MEM	PL [1:0]	M SIZE [1:0]	PSIZE [1:0]	MINC	PINC	CIRC	DIR	TEIE	HTIE	TCIE	EN										
	Reset value																0	0	0	0	0	0	0	0	0	0	0	0	0	0	0	0	0	0	0	0	0	0
0x05C	DMA_CNDTR5	Reserved															NDT[15:0]																					
	Reset value																0	0	0	0	0	0	0	0	0	0	0	0	0	0	0	0	0	0	0	0	0	0
0x060	DMA_CPAR5	PA[31:0]																																				
	Reset value	0	0	0	0	0	0	0	0	0	0	0	0	0	0	0	0	0	0	0	0	0	0	0	0	0	0	0	0	0	0	0	0	0	0			
0x064	DMA_CMAR5	MA[31:0]																																				
	Reset value	0	0	0	0	0	0	0	0	0	0	0	0	0	0	0	0	0	0	0	0	0	0	0	0	0	0	0	0	0	0	0	0	0	0			
0x068	Reserved																																					
0x06C	DMA_CCR6	Reserved															MEM2MEM	PL [1:0]	M SIZE [1:0]	PSIZE [1:0]	MINC	PINC	CIRC	DIR	TEIE	HTIE	TCIE	EN										
	Reset value																0	0	0	0	0	0	0	0	0	0	0	0	0	0	0	0	0	0	0	0	0	0
0x070	DMA_CNDTR6	Reserved															NDT[15:0]																					
	Reset value																0	0	0	0	0	0	0	0	0	0	0	0	0	0	0	0	0	0	0	0	0	0
0x074	DMA_CPAR6	PA[31:0]																																				
	Reset value	0	0	0	0	0	0	0	0	0	0	0	0	0	0	0	0	0	0	0	0	0	0	0	0	0	0	0	0	0	0	0	0	0	0			
0x078	DMA_CMAR6	MA[31:0]																																				
	Reset value	0	0	0	0	0	0	0	0	0	0	0	0	0	0	0	0	0	0	0	0	0	0	0	0	0	0	0	0	0	0	0	0	0	0			
0x07C	Reserved																																					
0x080	DMA_CCR7	Reserved															MEM2MEM	PL [1:0]	M SIZE [1:0]	PSIZE [1:0]	MINC	PINC	CIRC	DIR	TEIE	HTIE	TCIE	EN										
	Reset value																0	0	0	0	0	0	0	0	0	0	0	0	0	0	0	0	0	0	0	0	0	0
0x084	DMA_CNDTR7	Reserved															NDT[15:0]																					
	Reset value																0	0	0	0	0	0	0	0	0	0	0	0	0	0	0	0	0	0	0	0	0	0
0x088	DMA_CPAR7	PA[31:0]																																				
	Reset value	0	0	0	0	0	0	0	0	0	0	0	0	0	0	0	0	0	0	0	0	0	0	0	0	0	0	0	0	0	0	0	0	0	0			
0x08C	DMA_CMAR7	MA[31:0]																																				
	Reset value	0	0	0	0	0	0	0	0	0	0	0	0	0	0	0	0	0	0	0	0	0	0	0	0	0	0	0	0	0	0	0	0	0	0	0		
0x090	Reserved																																					

Refer to *Register boundary addresses* table.

## 11 Analog-to-digital converter (ADC)

**Low-density devices** are STM32F101xx, STM32F102xx and STM32F103xx microcontrollers where the Flash memory density ranges between 16 and 32 Kbytes.

**Medium-density devices** are STM32F101xx, STM32F102xx and STM32F103xx microcontrollers where the Flash memory density ranges between 64 and 128 Kbytes.

**High-density devices** are STM32F101xx and STM32F103xx microcontrollers where the Flash memory density ranges between 256 and 512 Kbytes.

**XL-density devices** are STM32F101xx and STM32F103xx microcontrollers where the Flash memory density ranges between 768 Kbytes and 1 Mbyte.

**Connectivity line devices** are STM32F105xx and STM32F107xx microcontrollers.

This Section applies to the whole STM32F10xxx family, unless otherwise specified.

### 11.1 ADC introduction

The 12-bit ADC is a successive approximation analog-to-digital converter. It has up to 18 multiplexed channels allowing it measure signals from 16 external and two internal sources. A/D conversion of the various channels can be performed in single, continuous, scan or discontinuous mode. The result of the ADC is stored in a left-aligned or right-aligned 16-bit data register.

The analog watchdog feature allows the application to detect if the input voltage goes outside the user-defined high or low thresholds.

The ADC input clock is generated from the PCLK2 clock divided by a prescaler and it must not exceed 14 MHz, refer to [Figure 8: Clock tree](#) for low-, medium-, high- and XL-density devices, and to [Figure 11: Clock tree](#) for connectivity line devices.

## 11.2 ADC main features

- 12-bit resolution
- Interrupt generation at End of Conversion, End of Injected conversion and Analog watchdog event
- Single and continuous conversion modes
- Scan mode for automatic conversion of channel 0 to channel 'n'
- Self-calibration
- Data alignment with in-built data coherency
- Channel by channel programmable sampling time
- External trigger option for both regular and injected conversion
- Discontinuous mode
- Dual mode (on devices with 2 ADCs or more)
- ADC conversion time:
  - STM32F103xx performance line devices: 1  $\mu$ s at 56 MHz (1.17  $\mu$ s at 72 MHz)
  - STM32F101xx access line devices: 1  $\mu$ s at 28 MHz (1.55  $\mu$ s at 36 MHz)
  - STM32F102xx USB access line devices: 1.2  $\mu$ s at 48 MHz
  - STM32F105xx and STM32F107xx devices: 1  $\mu$ s at 56 MHz (1.17  $\mu$ s at 72 MHz)
- ADC supply requirement: 2.4 V to 3.6 V
- ADC input range:  $V_{REF-} \leq V_{IN} \leq V_{REF+}$
- DMA request generation during regular channel conversion

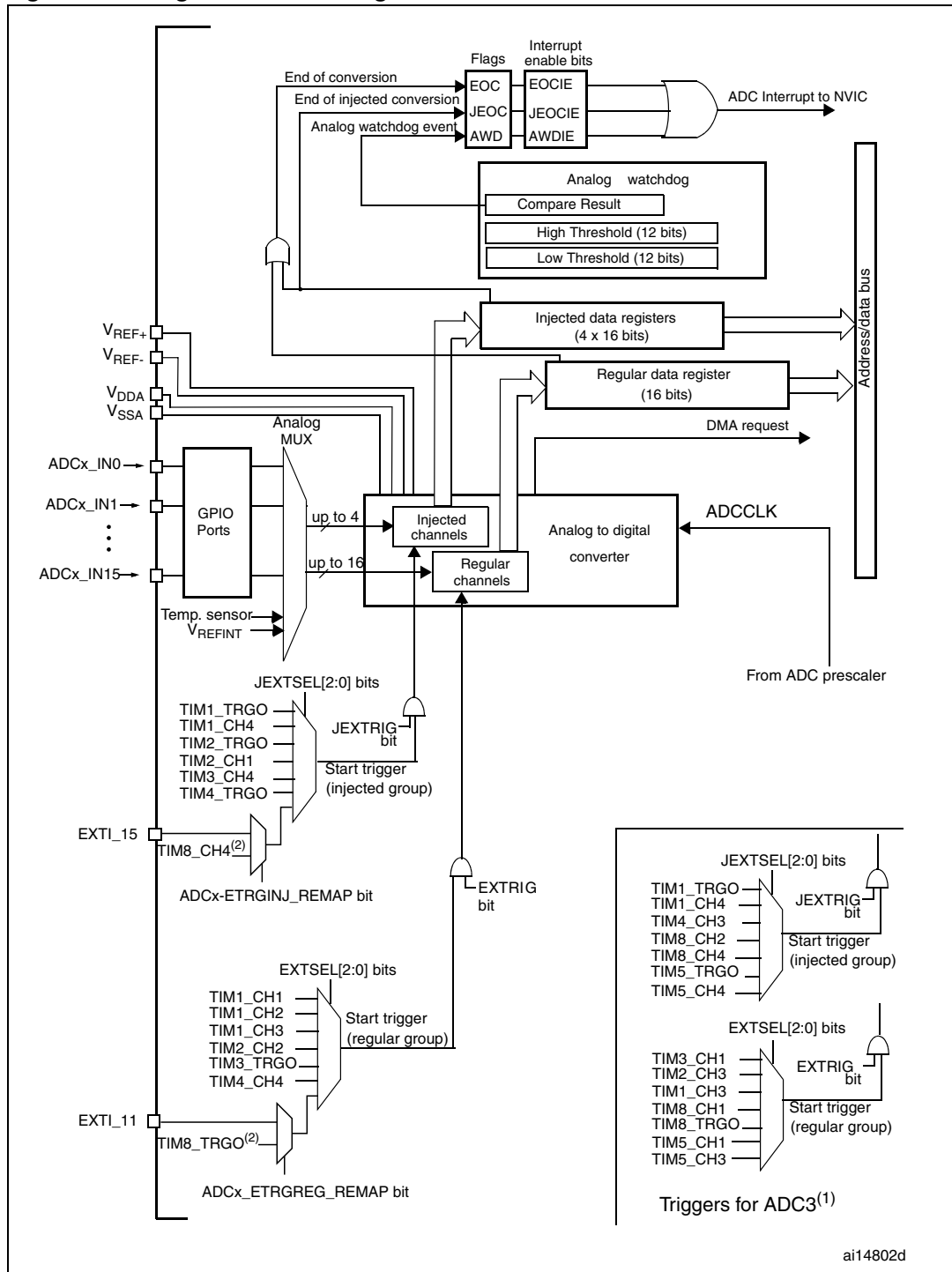
The block diagram of the ADC is shown in [Figure 26](#).

*Note:*  $V_{REF-}$ , if available (depending on package), must be tied to  $V_{SSA}$ .

## 11.3 ADC functional description

[Figure 26](#) shows a single ADC block diagram and [Table 68](#) gives the ADC pin description.

Figure 26. Single ADC block diagram



1. ADC3 has regular and injected conversion triggers different from those of ADC1 and ADC2.
2. TIM8\_CH4 and TIM8\_TRGO with their corresponding remap bits exist only in High-density and XL-density products.



Table 68. ADC pins

Name	Signal type	Remarks
$V_{REF+}$	Input, analog reference positive	The higher/positive reference voltage for the ADC, $2.4\text{ V} \leq V_{REF+} \leq V_{DDA}$
$V_{DDA}^{(1)}$	Input, analog supply	Analog power supply equal to $V_{DD}$ and $2.4\text{ V} \leq V_{DDA} \leq 3.6\text{ V}$
$V_{REF-}$	Input, analog reference negative	The lower/negative reference voltage for the ADC, $V_{REF-} = V_{SSA}$
$V_{SSA}^{(1)}$	Input, analog supply ground	Ground for analog power supply equal to $V_{SS}$
ADCx_IN[15:0]	Analog signals	16 analog channels

1.  $V_{DDA}$  and  $V_{SSA}$  have to be connected to  $V_{DD}$  and  $V_{SS}$ , respectively.

### 11.3.1 ADC on-off control

The ADC can be powered-on by setting the ADON bit in the ADC\_CR2 register. When the ADON bit is set for the first time, it wakes up the ADC from Power Down mode.

Conversion starts when ADON bit is set for a second time by software after ADC power-up time ( $t_{STAB}$ ).

You can stop conversion and put the ADC in power down mode by resetting the ADON bit. In this mode the ADC consumes almost no power (only a few  $\mu\text{A}$ ).

### 11.3.2 ADC clock

The ADCCLK clock provided by the Clock Controller is synchronous with the PCLK2 (APB2 clock). The RCC controller has a dedicated programmable prescaler for the ADC clock, refer to [Low-, medium-, high- and XL-density reset and clock control \(RCC\) on page 81](#) for more details.

### 11.3.3 Channel selection

There are 16 multiplexed channels. It is possible to organize the conversions in two groups: regular and injected. A group consists of a sequence of conversions which can be done on any channel and in any order. For instance, it is possible to do the conversion in the following order: Ch3, Ch8, Ch2, Ch2, Ch0, Ch2, Ch2, Ch15.

- The **regular group** is composed of up to 16 conversions. The regular channels and their order in the conversion sequence must be selected in the ADC\_SQRx registers. The total number of conversions in the regular group must be written in the L[3:0] bits in the ADC\_SQR1 register.
- The **injected group** is composed of up to 4 conversions. The injected channels and their order in the conversion sequence must be selected in the ADC\_JSQR register. The total number of conversions in the injected group must be written in the L[1:0] bits in the ADC\_JSQR register.

If the ADC\_SQRx or ADC\_JSQR registers are modified during a conversion, the current conversion is reset and a new start pulse is sent to the ADC to convert the new chosen group.

### Temperature sensor/ $V_{REFINT}$ internal channels

The Temperature sensor is connected to channel ADCx\_IN16 and the internal reference voltage  $V_{REFINT}$  is connected to ADCx\_IN17. These two internal channels can be selected and converted as injected or regular channels.

*Note:* The sensor and  $V_{REFINT}$  are only available on the master ADC1 peripheral.

### 11.3.4 Single conversion mode

In Single conversion mode the ADC does one conversion. This mode is started either by setting the ADON bit in the ADC\_CR2 register (for a regular channel only) or by external trigger (for a regular or injected channel), while the CONT bit is 0.

Once the conversion of the selected channel is complete:

- If a regular channel was converted:
  - The converted data is stored in the 16-bit ADC\_DR register
  - The EOC (End Of Conversion) flag is set
  - and an interrupt is generated if the EOCIE is set.
- If an injected channel was converted:
  - The converted data is stored in the 16-bit ADC\_DRJ1 register
  - The JEOC (End Of Conversion Injected) flag is set
  - and an interrupt is generated if the JEOCIE bit is set.

The ADC is then stopped.

### 11.3.5 Continuous conversion mode

In continuous conversion mode ADC starts another conversion as soon as it finishes one. This mode is started either by external trigger or by setting the ADON bit in the ADC\_CR2 register, while the CONT bit is 1.

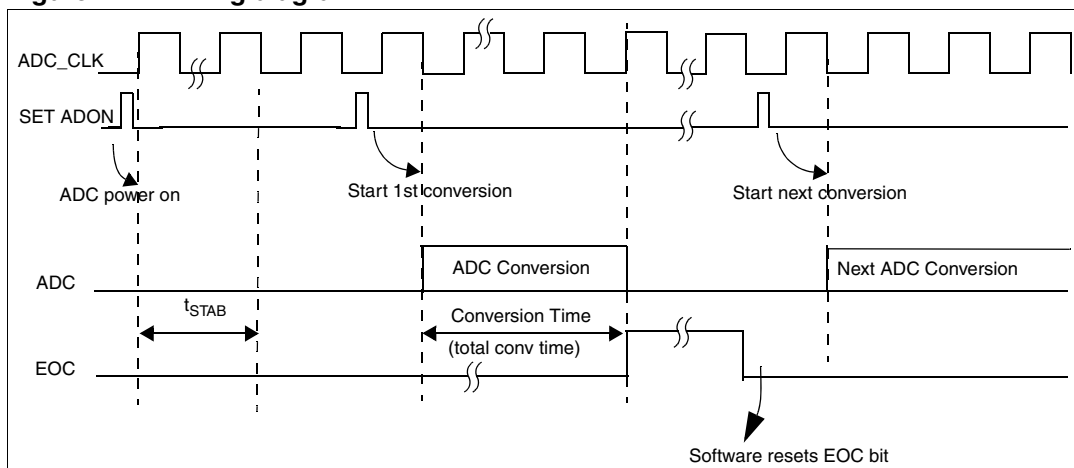
After each conversion:

- If a regular channel was converted:
  - The converted data is stored in the 16-bit ADC\_DR register
  - The EOC (End Of Conversion) flag is set
  - An interrupt is generated if the EOCIE is set.
- If an injected channel was converted:
  - The converted data is stored in the 16-bit ADC\_DRJ1 register
  - The JEOC (End Of Conversion Injected) flag is set
  - An interrupt is generated if the JEOCIE bit is set.

### 11.3.6 Timing diagram

As shown in [Figure 27](#), the ADC needs a stabilization time of  $t_{STAB}$  before it starts converting accurately. After the start of ADC conversion and after 14 clock cycles, the EOC flag is set and the 16-bit ADC Data register contains the result of the conversion.

Figure 27. Timing diagram



### 11.3.7 Analog watchdog

The AWD analog watchdog status bit is set if the analog voltage converted by the ADC is below a low threshold or above a high threshold. These thresholds are programmed in the 12 least significant bits of the ADC\_HTR and ADC\_LTR 16-bit registers. An interrupt can be enabled by using the AWDIE bit in the ADC\_CR1 register.

The threshold value is independent of the alignment selected by the ALIGN bit in the ADC\_CR2 register. The comparison is done before the alignment (see Section 11.5).

The analog watchdog can be enabled on one or more channels by configuring the ADC\_CR1 register as shown in Table 69.

Figure 28. Analog watchdog guarded area

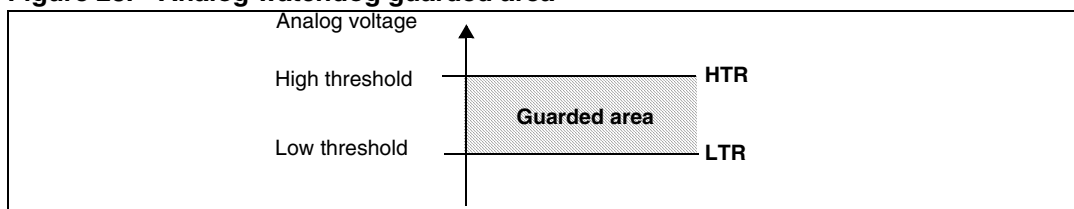


Table 69. Analog watchdog channel selection

Channels to be guarded by analog watchdog	ADC_CR1 register control bits (x = don't care)		
	AWDSGL bit	AWDEN bit	JAWDEN bit
None	x	0	0
All injected channels	0	0	1
All regular channels	0	1	0
All regular and injected channels	0	1	1
Single <sup>(1)</sup> injected channel	1	0	1
Single <sup>(1)</sup> regular channel	1	1	0
Single <sup>(1)</sup> regular or injected channel	1	1	1

1. Selected by AWDCH[4:0] bits

### 11.3.8 Scan mode

This mode is used to scan a group of analog channels.

Scan mode can be selected by setting the SCAN bit in the ADC\_CR1 register. Once this bit is set, ADC scans all the channels selected in the ADC\_SQRx registers (for regular channels) or in the ADC\_JSQR (for injected channels). A single conversion is performed for each channel of the group. After each end of conversion the next channel of the group is converted automatically. If the CONT bit is set, conversion does not stop at the last selected group channel but continues again from the first selected group channel.

If the DMA bit is set, the direct memory access controller is used to transfer the converted data of regular group channels to SRAM after each EOC.

The injected channel converted data is always stored in the ADC\_JDRx registers.

### 11.3.9 Injected channel management

#### Triggered injection

To use triggered injection, the JAUTO bit must be cleared and SCAN bit must be set in the ADC\_CR1 register.

1. Start conversion of a group of regular channels either by external trigger or by setting the ADON bit in the ADC\_CR2 register.
2. If an external injected trigger occurs during the regular group channel conversion, the current conversion is reset and the injected channel sequence is converted in Scan once mode.
3. Then, the regular group channel conversion is resumed from the last interrupted regular conversion. If a regular event occurs during an injected conversion, it doesn't interrupt it but the regular sequence is executed at the end of the injected sequence.

*Figure 29* shows the timing diagram.

*Note:* When using triggered injection, one must ensure that the interval between trigger events is longer than the injection sequence. For instance, if the sequence length is 28 ADC clock cycles (that is two conversions with a 1.5 clock-period sampling time), the minimum interval between triggers must be 29 ADC clock cycles.

#### Auto-injection

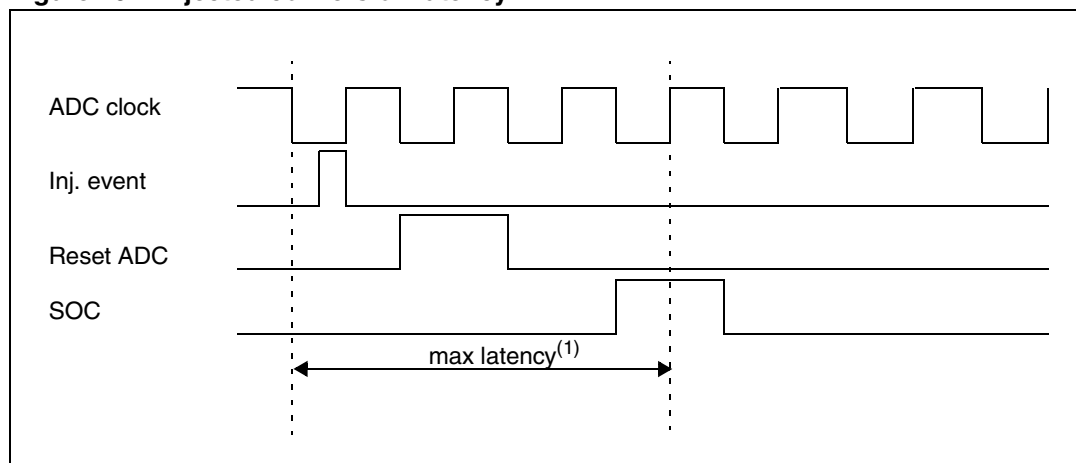
If the JAUTO bit is set, then the injected group channels are automatically converted after the regular group channels. This can be used to convert a sequence of up to 20 conversions programmed in the ADC\_SQRx and ADC\_JSQR registers.

In this mode, external trigger on injected channels must be disabled.

If the CONT bit is also set in addition to the JAUTO bit, regular channels followed by injected channels are continuously converted.

For ADC clock prescalers ranging from 4 to 8, a delay of 1 ADC clock period is automatically inserted when switching from regular to injected sequence (respectively injected to regular). When the ADC clock prescaler is set to 2, the delay is 2 ADC clock periods.

*Note:* It is not possible to use both auto-injected and discontinuous modes simultaneously.

**Figure 29. Injected conversion latency**

1. The maximum latency value can be found in the electrical characteristics of the STM32F101xx and STM32F103xx datasheets.

### 11.3.10 Discontinuous mode

#### Regular group

This mode is enabled by setting the DISCEN bit in the ADC\_CR1 register. It can be used to convert a short sequence of  $n$  conversions ( $n \leq 8$ ) which is a part of the sequence of conversions selected in the ADC\_SQRx registers. The value of  $n$  is specified by writing to the DISCNUM[2:0] bits in the ADC\_CR1 register.

When an external trigger occurs, it starts the next  $n$  conversions selected in the ADC\_SQRx registers until all the conversions in the sequence are done. The total sequence length is defined by the L[3:0] bits in the ADC\_SQR1 register.

Example:

$n = 3$ , channels to be converted = 0, 1, 2, 3, 6, 7, 9, 10  
 1st trigger: sequence converted 0, 1, 2  
 2nd trigger: sequence converted 3, 6, 7  
 3rd trigger: sequence converted 9, 10 and an EOC event generated  
 4th trigger: sequence converted 0, 1, 2

*Note:* When a regular group is converted in discontinuous mode, no rollover will occur.

When all sub groups are converted, the next trigger starts conversion of the first sub-group. In the example above, the 4th trigger reconverts the 1st sub-group channels 0, 1 and 2.

#### Injected group

This mode is enabled by setting the JDISCEN bit in the ADC\_CR1 register. It can be used to convert the sequence selected in the ADC\_JSQR register, channel by channel, after an external trigger event.

When an external trigger occurs, it starts the next channel conversions selected in the ADC\_JSQR registers until all the conversions in the sequence are done. The total sequence length is defined by the JL[1:0] bits in the ADC\_JSQR register.

Example:

- n = 1, channels to be converted = 1, 2, 3
- 1st trigger: channel 1 converted
- 2nd trigger: channel 2 converted
- 3rd trigger: channel 3 converted and EOC and JEOC events generated
- 4th trigger: channel 1

- Note:*
- 1 When all injected channels are converted, the next trigger starts the conversion of the first injected channel. In the example above, the 4th trigger reconverts the 1st injected channel 1.
  - 2 It is not possible to use both auto-injected and discontinuous modes simultaneously.
  - 3 The user must avoid setting discontinuous mode for both regular and injected groups together. Discontinuous mode must be enabled only for one group conversion.

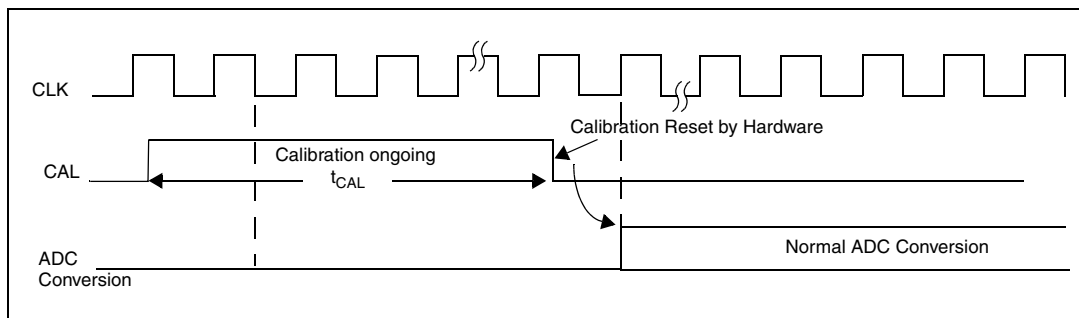
### 11.4 Calibration

The ADC has an built-in self calibration mode. Calibration significantly reduces accuracy errors due to internal capacitor bank variations. During calibration, an error-correction code (digital word) is calculated for each capacitor, and during all subsequent conversions, the error contribution of each capacitor is removed using this code.

Calibration is started by setting the CAL bit in the ADC\_CR2 register. Once calibration is over, the CAL bit is reset by hardware and normal conversion can be performed. It is recommended to calibrate the ADC once at power-on. The calibration codes are stored in the ADC\_DR as soon as the calibration phase ends.

- Note:*
- 1 It is recommended to perform a calibration after each power-up.
  - 2 Before starting a calibration the ADC must have been in power-off state (ADON bit = '0') for at least two ADC clock cycles.

**Figure 30. Calibration timing diagram**



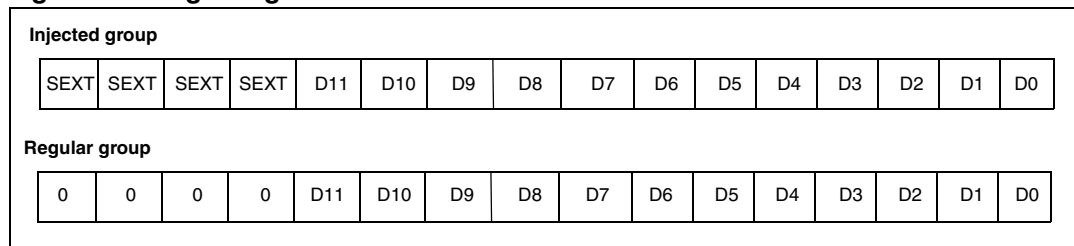
### 11.5 Data alignment

ALIGN bit in the ADC\_CR2 register selects the alignment of data stored after conversion. Data can be left or right aligned as shown in [Figure 31](#). and [Figure 32](#).

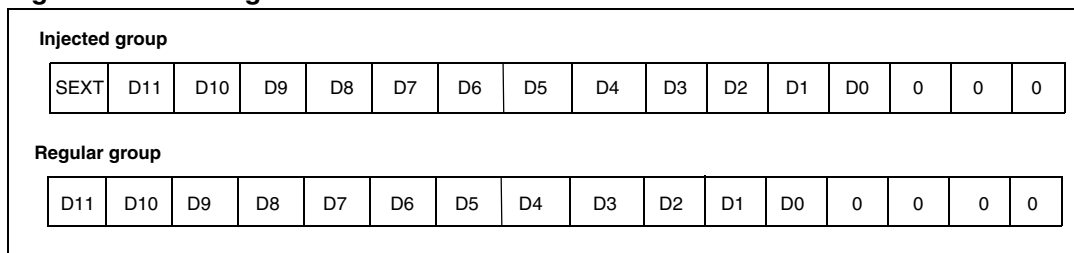
The injected group channels converted data value is decreased by the user-defined offset written in the ADC\_JOFRx registers so the result can be a negative value. The SEXT bit is the extended sign value.

For regular group channels no offset is subtracted so only twelve bits are significant.

**Figure 31. Right alignment of data**



**Figure 32. Left alignment of data**



## 11.6 Channel-by-channel programmable sample time

ADC samples the input voltage for a number of ADC\_CLK cycles which can be modified using the SMP[2:0] bits in the ADC\_SMPR1 and ADC\_SMPR2 registers. Each channel can be sampled with a different sample time.

The total conversion time is calculated as follows:

$$T_{conv} = \text{Sampling time} + 12.5 \text{ cycles}$$

Example:

With an ADCCLK = 14 MHz and a sampling time of 1.5 cycles:

$$T_{conv} = 1.5 + 12.5 = 14 \text{ cycles} = 1 \mu\text{s}$$

## 11.7 Conversion on external trigger

Conversion can be triggered by an external event (e.g. timer capture, EXTI line). If the EXT-TRIG control bit is set then external events are able to trigger a conversion. The EXT-SEL[2:0] and JEXTSEL[2:0] control bits allow the application to select decide which out of 8 possible events can trigger conversion for the regular and injected groups.

*Note: When an external trigger is selected for ADC regular or injected conversion, only the rising edge of the signal can start the conversion.*

**Table 70. External trigger for regular channels for ADC1 and ADC2**

Source	Type	EXTSEL[2:0]
TIM1_CC1 event	Internal signal from on-chip timers	000
TIM1_CC2 event		001
TIM1_CC3 event		010
TIM2_CC2 event		011
TIM3_TRGO event		100
TIM4_CC4 event		101
EXTI line11/TIM8_TRGO event <sup>(1)(2)</sup>	External pin/Internal signal from on-chip timers	110
SWSTART	Software control bit	111

1. The TIM8\_TRGO event exists only in high-density and XL-density devices.
2. The selection of the external trigger EXTI line11 or TIM8\_TRGO event for regular channels is done through configuration bits ADC1\_ETRGREG\_REMAP and ADC2\_ETRGREG\_REMAP for ADC1 and ADC2, respectively.

**Table 71. External trigger for injected channels for ADC1 and ADC2**

Source	Connection type	JEXTSEL[2:0]
TIM1_TRGO event	Internal signal from on-chip timers	000
TIM1_CC4 event		001
TIM2_TRGO event		010
TIM2_CC1 event		011
TIM3_CC4 event		100
TIM4_TRGO event		101
EXTI line15/TIM8_CC4 event <sup>(1)(2)</sup>	External pin/Internal signal from on-chip timers	110
JSWSTART	Software control bit	111

1. The TIM8\_CC4 event exists only in high-density and XL-density devices.
2. The selection of the external trigger EXTI line15 or TIM8\_CC4 event for injected channels is done through configuration bits ADC1\_ETRGINJ\_REMAP and ADC2\_ETRGINJ\_REMAP for ADC1 and ADC2, respectively.



**Table 72. External trigger for regular channels for ADC3**

Source	Connection type	EXTSEL[2:0]
TIM3_CC1 event	Internal signal from on-chip timers	000
TIM2_CC3 event		001
TIM1_CC3 event		010
TIM8_CC1 event		011
TIM8_TRGO event		100
TIM5_CC1 event		101
TIM5_CC3 event		110
SWSTART	Software control bit	111

**Table 73. External trigger for injected channels for ADC3**

Source	Connection type	JEXTSEL[2:0]
TIM1_TRGO event	Internal signal from on-chip timers	000
TIM1_CC4 event		001
TIM4_CC3 event		010
TIM8_CC2 event		011
TIM8_CC4 event		100
TIM5_TRGO event		101
TIM5_CC4 event		110
JSWSTART	Software control bit	111

The software source trigger events can be generated by setting a bit in a register (SWSTART and JSWSTART in ADC\_CR2).

A regular group conversion can be interrupted by an injected trigger.

## 11.8 DMA request

Since converted regular channels value are stored in a unique data register, it is necessary to use DMA for conversion of more than one regular channel. This avoids the loss of data already stored in the ADC\_DR register.

Only the end of conversion of a regular channel generates a DMA request, which allows the transfer of its converted data from the ADC\_DR register to the destination location selected by the user.

*Note:* Only ADC1 and ADC3 have this DMA capability. ADC2-converted data can be transferred in dual ADC mode using DMA thanks to master ADC1.

## 11.9 Dual ADC mode

In devices with two ADCs or more, dual ADC mode can be used (see [Figure 33](#)).

In dual ADC mode the start of conversion is triggered alternately or simultaneously by the ADC1 master to the ADC2 slave, depending on the mode selected by the DUALMOD[2:0] bits in the ADC1\_CR1 register.

*Note:* In dual mode, when configuring conversion to be triggered by an external event, the user must set the trigger for the master only and set a software trigger for the slave to prevent spurious triggers to start unwanted slave conversion. However, external triggers must be enabled on both master and slave ADCs.

The following six possible modes are implemented:

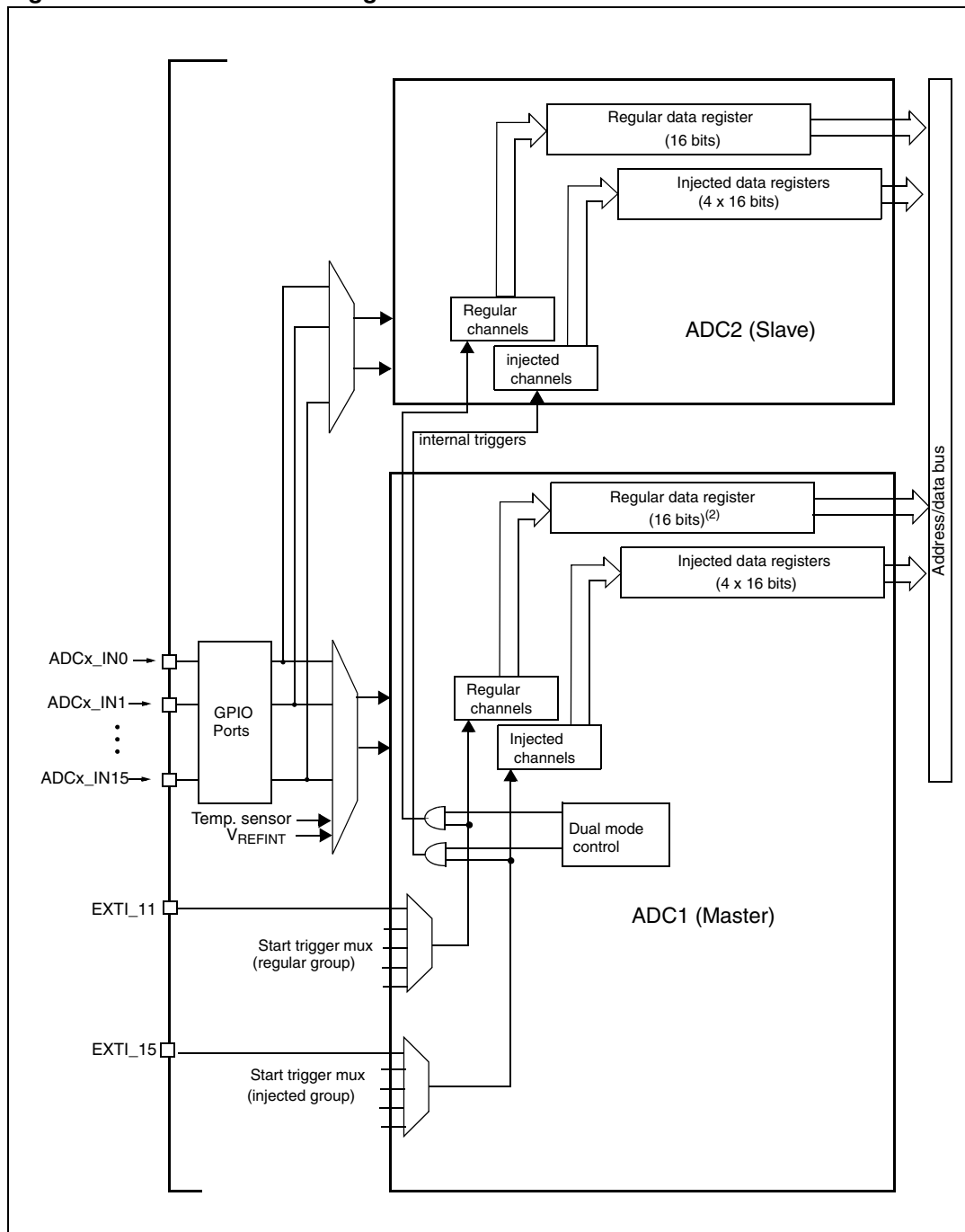
- Injected simultaneous mode
- Regular simultaneous mode
- Fast interleaved mode
- Slow interleaved mode
- Alternate trigger mode
- Independent mode

It is also possible to use the previous modes combined in the following ways:

- Injected simultaneous mode + Regular simultaneous mode
- Regular simultaneous mode + Alternate trigger mode
- Injected simultaneous mode + Interleaved mode

*Note:* In dual ADC mode, to read the slave converted data on the master data register, the DMA bit must be enabled even if it is not used to transfer converted regular channel data.

Figure 33. Dual ADC block diagram<sup>(1)</sup>



1. External triggers are present on ADC2 but are not shown for the purposes of this diagram.
2. In some dual ADC modes, the ADC1 data register (ADC1\_DR) contains both ADC1 and ADC2 regular converted data over the entire 32 bits.

### 11.9.1 Injected simultaneous mode

This mode converts an injected channel group. The source of external trigger comes from the injected group mux of ADC1 (selected by the JEXTSEL[2:0] bits in the ADC1\_CR2 register). A simultaneous trigger is provided to ADC2.

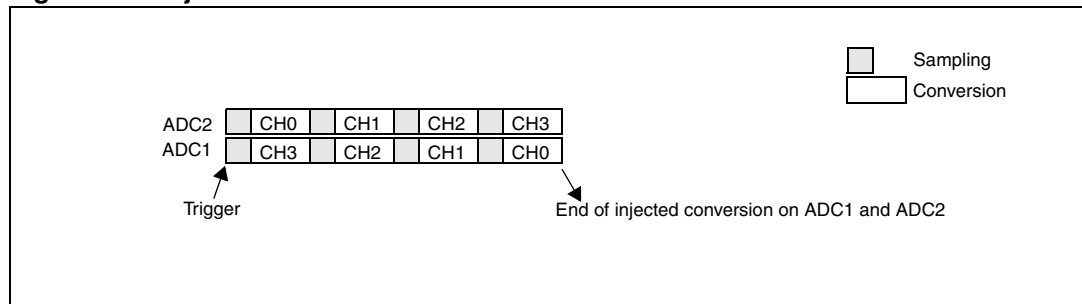
*Note:* Do not convert the same channel on the two ADCs (no overlapping sampling times for the two ADCs when converting the same channel).

At the end of conversion event on ADC1 or ADC2:

- The converted data is stored in the ADC\_JDRx registers of each ADC interface.
- An JEOC interrupt is generated (if enabled on one of the two ADC interfaces) when the ADC1/ADC2 injected channels are all converted.

*Note:* In simultaneous mode, one must convert sequences with the same length or ensure that the interval between triggers is longer than the longest of the 2 sequences. Otherwise, the ADC with the shortest sequence may restart while the ADC with the longest sequence is completing the previous conversions.

**Figure 34. Injected simultaneous mode on 4 channels**



### 11.9.2 Regular simultaneous mode

This mode is performed on a regular channel group. The source of the external trigger comes from the regular group mux of ADC1 (selected by the EXTSEL[2:0] bits in the ADC1\_CR2 register). A simultaneous trigger is provided to the ADC2.

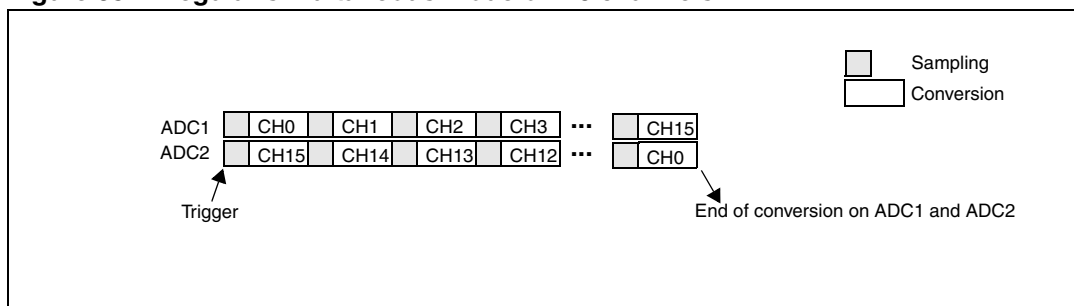
*Note:* Do not convert the same channel on the two ADCs (no overlapping sampling times for the two ADCs when converting the same channel).

At the end of conversion event on ADC1 or ADC2:

- A 32-bit DMA transfer request is generated (if DMA bit is set) which transfers to SRAM the ADC1\_DR 32-bit register containing the ADC2 converted data in the upper halfword and the ADC1 converted data in the lower halfword.
- An EOC interrupt is generated (if enabled on one of the two ADC interfaces) when ADC1/ADC2 regular channels are all converted.

*Note:* In regular simultaneous mode, one must convert sequences with the same length or ensure that the interval between triggers is longer than the longest of the 2 sequences. Otherwise, the ADC with the shortest sequence may restart while the ADC with the longest sequence is completing the previous conversions.

**Figure 35. Regular simultaneous mode on 16 channels**



### 11.9.3 Fast interleaved mode

This mode can be started only on a regular channel group (usually one channel). The source of external trigger comes from the regular channel mux of ADC1. After an external trigger occurs:

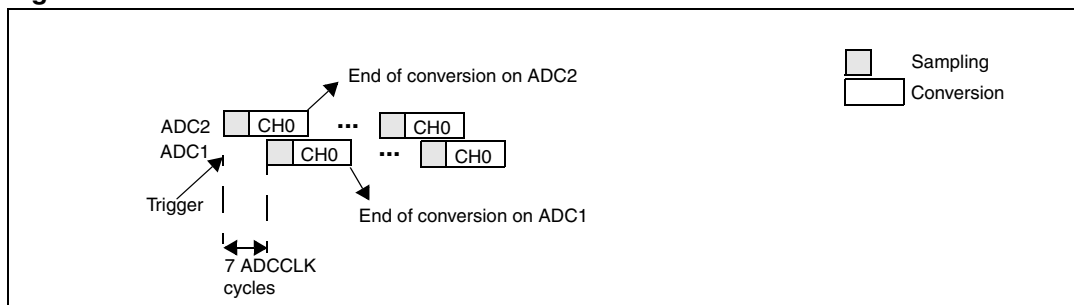
- ADC2 starts immediately and
- ADC1 starts after a delay of 7 ADC clock cycles.

If CONT bit is set on both ADC1 and ADC2 the selected regular channels of both ADCs are continuously converted.

After an EOC interrupt is generated by ADC1 (if enabled through the EOCIE bit) a 32-bit DMA transfer request is generated (if the DMA bit is set) which transfers to SRAM the ADC1\_DR 32-bit register containing the ADC2 converted data in the upper halfword and the ADC1 converted data in the lower halfword.

*Note: The maximum sampling time allowed is <7 ADCCLK cycles to avoid the overlap between ADC1 and ADC2 sampling phases in the event that they convert the same channel.*

**Figure 36. Fast interleaved mode on 1 channel in continuous conversion mode**



### 11.9.4 Slow interleaved mode

This mode can be started only on a regular channel group (only one channel). The source of external trigger comes from regular channel mux of ADC1. After external trigger occurs:

- ADC2 starts immediately and
- ADC1 starts after a delay of 14 ADC clock cycles.
- ADC2 starts after a second delay of 14 ADC cycles, and so on.

*Note: The maximum sampling time allowed is <14 ADCCLK cycles to avoid an overlap with the next conversion.*

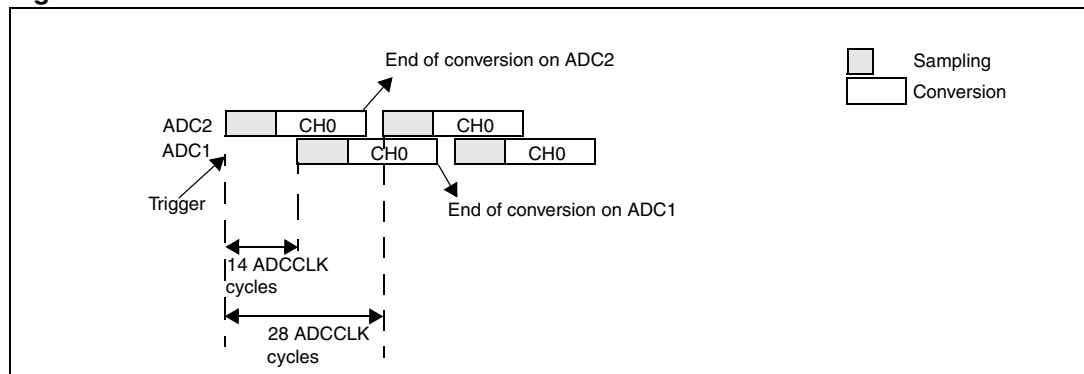
After an EOC interrupt is generated by ADC1 (if enabled through the EOCIE bit) a 32-bit DMA transfer request is generated (if the DMA bit is set) which transfers to SRAM the ADC1\_DR 32-bit register containing the ADC2 converted data in the upper halfword and the ADC1 converted data in the lower halfword.

A new ADC2 start is automatically generated after 28 ADC clock cycles

CONT bit can not be set in the mode since it continuously converts the selected regular channel.

*Note: The application must ensure that no external trigger for injected channel occurs when interleaved mode is enabled.*

**Figure 37. Slow interleaved mode on 1 channel**



### 11.9.5 Alternate trigger mode

This mode can be started only on an injected channel group. The source of external trigger comes from the injected group mux of ADC1.

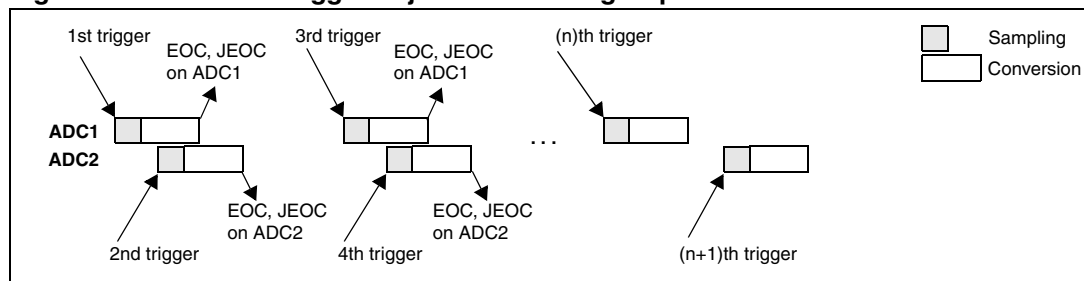
- When the 1st trigger occurs, all injected group channels in ADC1 are converted.
- When the 2nd trigger arrives, all injected group channels in ADC2 are converted
- and so on.

A JEOP interrupt, if enabled, is generated after all injected group channels of ADC1 are converted.

A JEOP interrupt, if enabled, is generated after all injected group channels of ADC2 are converted.

If another external trigger occurs after all injected group channels have been converted then the alternate trigger process restarts by converting ADC1 injected group channels.

**Figure 38. Alternate trigger: injected channel group of each ADC**



If the injected discontinuous mode is enabled for both ADC1 and ADC2:

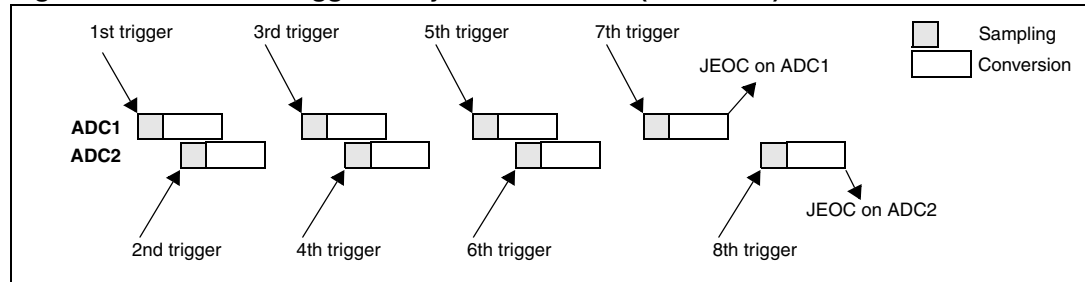
- When the 1st trigger occurs, the first injected channel in ADC1 is converted.
- When the 2nd trigger arrives, the first injected channel in ADC2 are converted
- and so on....

A JEOC interrupt, if enabled, is generated after all injected group channels of ADC1 are converted.

A JEOC interrupt, if enabled, is generated after all injected group channels of ADC2 are converted.

If another external trigger occurs after all injected group channels have been converted then the alternate trigger process restarts.

**Figure 39. Alternate trigger: 4 injected channels (each ADC) in discontinuous model**



### 11.9.6 Independent mode

In this mode the dual ADC synchronization is bypassed and each ADC interfaces works independently.

### 11.9.7 Combined regular/injected simultaneous mode

It is possible to interrupt simultaneous conversion of a regular group to start simultaneous conversion of an injected group.

*Note:* In combined regular/injected simultaneous mode, one must convert sequences with the same length or ensure that the interval between triggers is longer than the longest of the 2 sequences. Otherwise, the ADC with the shortest sequence may restart while the ADC with the longest sequence is completing the previous conversions.

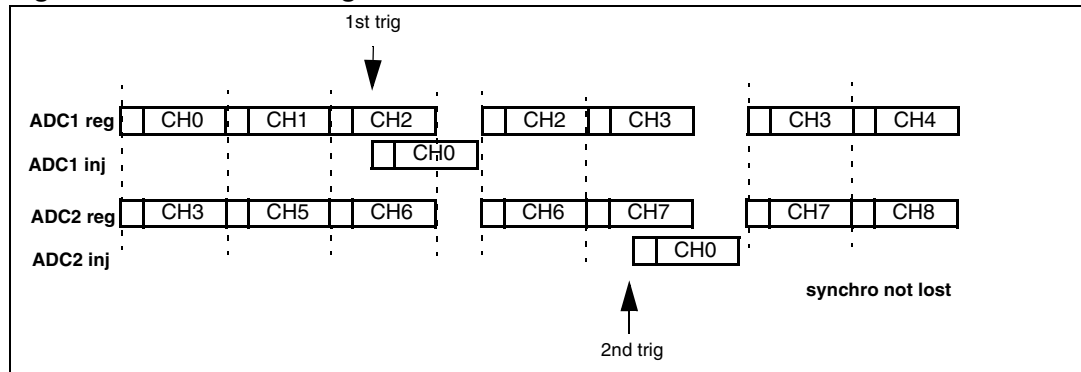
### 11.9.8 Combined regular simultaneous + alternate trigger mode

It is possible to interrupt regular group simultaneous conversion to start alternate trigger conversion of an injected group. [Figure 40](#) shows the behavior of an alternate trigger interrupting a regular simultaneous conversion.

The injected alternate conversion is immediately started after the injected event arrives. If regular conversion is already running, in order to ensure synchronization after the injected conversion, the regular conversion of both (master/slave) ADCs is stopped and resumed synchronously at the end of the injected conversion.

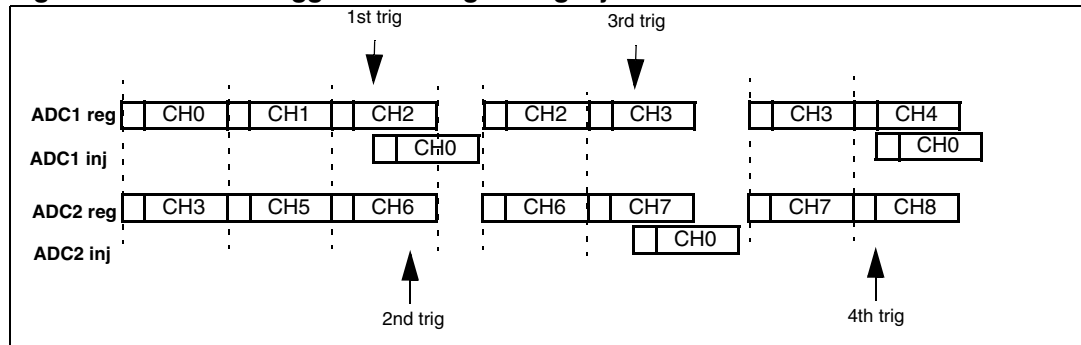
*Note:* In combined regular simultaneous + alternate trigger mode, one must convert sequences with the same length or ensure that the interval between triggers is longer than the longest of the 2 sequences. Otherwise, the ADC with the shortest sequence may restart while the ADC with the longest sequence is completing the previous conversions.

**Figure 40. Alternate + Regular simultaneous**



If a trigger occurs during an injected conversion that has interrupted a regular conversion, it will be ignored. [Figure 41](#) shows the behavior in this case (2nd trig is ignored).

**Figure 41. Case of trigger occurring during injected conversion**

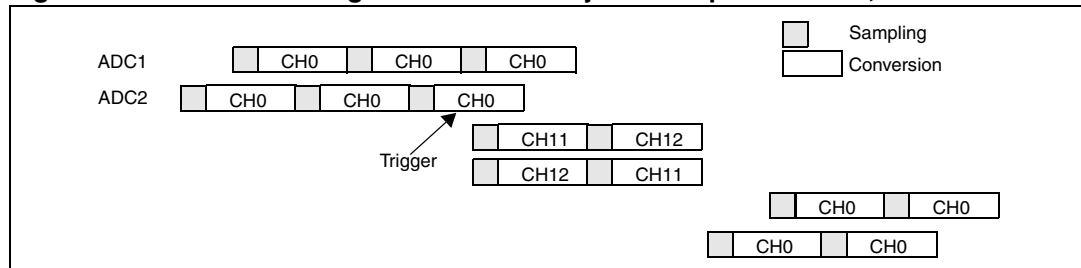


### 11.9.9 Combined injected simultaneous + interleaved

It is possible to interrupt an interleaved conversion with an injected event. In this case the interleaved conversion is interrupted and the injected conversion starts, at the end of the injected sequence the interleaved conversion is resumed. [Figure 42](#) shows the behavior using an example.

*Note:* When the ADC clock prescaler is set to 4, the interleaved mode does not recover with evenly spaced sampling periods: the sampling interval is 8 ADC clock periods followed by 6 ADC clock periods, instead of 7 clock periods followed by 7 clock periods.

**Figure 42. Interleaved single channel with injected sequence CH11, CH12**





## 11.10 Temperature sensor

The temperature sensor can be used to measure the ambient temperature ( $T_A$ ) of the device.

The temperature sensor is internally connected to the ADCx\_IN16 input channel which is used to convert the sensor output voltage into a digital value. The recommended sampling time for the temperature sensor is 17.1  $\mu$ s.

The block diagram of the temperature sensor is shown in [Figure 43](#).

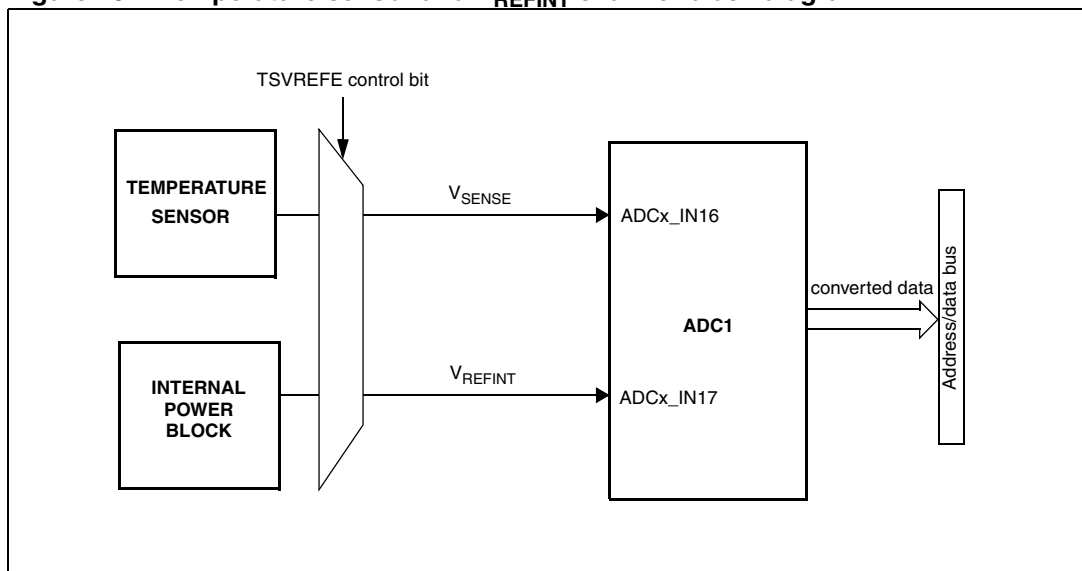
When not in use, this sensor can be put in power down mode.

*Note: The TSVREFE bit must be set to enable both internal channels: ADCx\_IN16 (temperature sensor) and ADCx\_IN17 ( $V_{REFINT}$ ) conversion.*

The temperature sensor output voltage changes linearly with temperature. The offset of this line varies from chip to chip due to process variation (up to 45 °C from one chip to another).

The internal temperature sensor is more suited to applications that detect temperature variations instead of absolute temperatures. If accurate temperature readings are needed, an external temperature sensor part should be used.

**Figure 43. Temperature sensor and  $V_{REFINT}$  channel block diagram**



### Reading the temperature

To use the sensor:

1. Select the ADCx\_IN16 input channel.
2. Select a sample time of 17.1 μs
3. Set the TSVREFE bit in the *ADC control register 2 (ADC\_CR2)* to wake up the temperature sensor from power down mode.
4. Start the ADC conversion by setting the ADON bit (or by external trigger).
5. Read the resulting V<sub>SENSE</sub> data in the ADC data register
6. Obtain the temperature using the following formula:

$$\text{Temperature (in } ^\circ\text{C)} = \{(V_{25} - V_{\text{SENSE}}) / \text{Avg\_Slope}\} + 25.$$

Where,

V<sub>25</sub> = V<sub>SENSE</sub> value for 25° C and

Avg\_Slope = Average Slope for curve between Temperature vs. V<sub>SENSE</sub> (given in mV/° C or μV/ °C).

Refer to the Electrical characteristics section for the actual values of V<sub>25</sub> and Avg\_Slope.

*Note:* The sensor has a startup time after waking from power down mode before it can output V<sub>SENSE</sub> at the correct level. The ADC also has a startup time after power-on, so to minimize the delay, the ADON and TSVREFE bits should be set at the same time.

## 11.11 ADC interrupts

An interrupt can be produced on end of conversion for regular and injected groups and when the analog watchdog status bit is set. Separate interrupt enable bits are available for flexibility.

*Note:* ADC1 and ADC2 interrupts are mapped onto the same interrupt vector. ADC3 interrupts are mapped onto a separate interrupt vector.

Two other flags are present in the ADC\_SR register, but there is no interrupt associated with them:

- JSTRT (Start of conversion for injected group channels)
- STRT (Start of conversion for regular group channels)

**Table 74. ADC interrupts**

Interrupt event	Event flag	Enable Control bit
End of conversion regular group	EOC	EOCIE
End of conversion injected group	JEOC	JEOCIE
Analog watchdog status bit is set	AWD	AWDIE

## 11.12 ADC registers

Refer to [Section 1.1 on page 40](#) for a list of abbreviations used in register descriptions.

The peripheral registers have to be accessed by words (32-bit).

### 11.12.1 ADC status register (ADC\_SR)

Address offset: 0x00

Reset value: 0x0000 0000

31	30	29	28	27	26	25	24	23	22	21	20	19	18	17	16
Reserved															
15	14	13	12	11	10	9	8	7	6	5	4	3	2	1	0
Reserved											STRT	JSTRT	JEOC	EOC	AWD
Reserved											rc_w0	rc_w0	rc_w0	rc_w0	rc_w0

Bits 31:5 Reserved, must be kept cleared.

Bit 4 **STRT**: Regular channel Start flag

This bit is set by hardware when regular channel conversion starts. It is cleared by software.

0: No regular channel conversion started

1: Regular channel conversion has started

Bit 3 **JSTRT**: Injected channel Start flag

This bit is set by hardware when injected channel group conversion starts. It is cleared by software.

0: No injected group conversion started

1: Injected group conversion has started

Bit 2 **JEOC**: Injected channel end of conversion

This bit is set by hardware at the end of all injected group channel conversion. It is cleared by software.

0: Conversion is not complete

1: Conversion complete

Bit 1 **EOC**: End of conversion

This bit is set by hardware at the end of a group channel conversion (regular or injected). It is cleared by software or by reading the ADC\_DR.

0: Conversion is not complete

1: Conversion complete

Bit 0 **AWD**: Analog watchdog flag

This bit is set by hardware when the converted voltage crosses the values programmed in the ADC\_LTR and ADC\_HTR registers. It is cleared by software.

0: No Analog watchdog event occurred

1: Analog watchdog event occurred

### 11.12.2 ADC control register 1 (ADC\_CR1)

Address offset: 0x04

Reset value: 0x0000 0000

31	30	29	28	27	26	25	24	23	22	21	20	19	18	17	16	
Reserved								AWDEN	JAWDEN	Reserved			DUALMOD[3:0]			
Res.								rw	rw	Res.			rw	rw	rw	rw
15	14	13	12	11	10	9	8	7	6	5	4	3	2	1	0	
DISCNUM[2:0]			JDISCEN	DISCEN	JAUTO	AWDSGL	SCAN	JEOCIE	AWDIE	EOCIE	AWDCH[4:0]					
rw	rw	rw	rw	rw	rw	rw	rw	rw	rw	rw	rw	rw	rw	rw	rw	

Bits 31:24 Reserved, must be kept cleared.

Bit 23 **AWDEN**: Analog watchdog enable on regular channels

This bit is set/reset by software.

0: Analog watchdog disabled on regular channels

1: Analog watchdog enabled on regular channels

Bit 22 **JAWDEN**: Analog watchdog enable on injected channels

This bit is set/reset by software.

0: Analog watchdog disabled on injected channels

1: Analog watchdog enabled on injected channels

Bits 21:20 Reserved, must be kept cleared.

Bits 19:16 **DUALMOD[3:0]**: Dual mode selection

These bits are written by software to select the operating mode.

0000: Independent mode.

0001: Combined regular simultaneous + injected simultaneous mode

0010: Combined regular simultaneous + alternate trigger mode

0011: Combined injected simultaneous + fast interleaved mode

0100: Combined injected simultaneous + slow Interleaved mode

0101: Injected simultaneous mode only

0110: Regular simultaneous mode only

0111: Fast interleaved mode only

1000: Slow interleaved mode only

1001: Alternate trigger mode only

*Note: These bits are reserved in ADC2 and ADC3.*

*In dual mode, a change of channel configuration generates a restart that can produce a loss of synchronization. It is recommended to disable dual mode before any configuration change.*

Bits 15:13 **DISCNUM[2:0]**: Discontinuous mode channel count

These bits are written by software to define the number of regular channels to be converted in discontinuous mode, after receiving an external trigger.

000: 1 channel

001: 2 channels

.....

111: 8 channels

- Bit 12 **JDSCEN**: Discontinuous mode on injected channels  
This bit set and cleared by software to enable/disable discontinuous mode on injected group channels  
0: Discontinuous mode on injected channels disabled  
1: Discontinuous mode on injected channels enabled
- Bit 11 **DISCEN**: Discontinuous mode on regular channels  
This bit set and cleared by software to enable/disable Discontinuous mode on regular channels.  
0: Discontinuous mode on regular channels disabled  
1: Discontinuous mode on regular channels enabled
- Bit 10 **JAUTO**: Automatic Injected Group conversion  
This bit set and cleared by software to enable/disable automatic injected group conversion after regular group conversion.  
0: Automatic injected group conversion disabled  
1: Automatic injected group conversion enabled
- Bit 9 **AWDSGL**: Enable the watchdog on a single channel in scan mode  
This bit set and cleared by software to enable/disable the analog watchdog on the channel identified by the AWDCH[4:0] bits.  
0: Analog watchdog enabled on all channels  
1: Analog watchdog enabled on a single channel
- Bit 8 **SCAN**: Scan mode  
This bit is set and cleared by software to enable/disable Scan mode. In Scan mode, the inputs selected through the ADC\_SQRx or ADC\_JSQRx registers are converted.  
0: Scan mode disabled  
1: Scan mode enabled  
*Note: An EOC or JEOC interrupt is generated only on the end of conversion of the last channel if the corresponding EOCIE or JEOCIE bit is set*
- Bit 7 **JEOCIE**: Interrupt enable for injected channels  
This bit is set and cleared by software to enable/disable the end of conversion interrupt for injected channels.  
0: JEOC interrupt disabled  
1: JEOC interrupt enabled. An interrupt is generated when the JEOC bit is set.
- Bit 6 **AWDIE**: Analog watchdog interrupt enable  
This bit is set and cleared by software to enable/disable the analog watchdog interrupt. In Scan mode if the watchdog thresholds are crossed, scan is aborted only if this bit is enabled.  
0: Analog watchdog interrupt disabled  
1: Analog watchdog interrupt enabled
- Bit 5 **EOCIE**: Interrupt enable for EOC  
This bit is set and cleared by software to enable/disable the End of Conversion interrupt.  
0: EOC interrupt disabled  
1: EOC interrupt enabled. An interrupt is generated when the EOC bit is set.

Bits 4:0 **AWDCH[4:0]**: Analog watchdog channel select bits

These bits are set and cleared by software. They select the input channel to be guarded by the Analog watchdog.

00000: ADC analog Channel0

00001: ADC analog Channel1

....

01111: ADC analog Channel15

10000: ADC analog Channel16

10001: ADC analog Channel17

Other values reserved.

*Note: ADC1 analog Channel16 and Channel17 are internally connected to the temperature sensor and to  $V_{REFINT}$ , respectively.*

*ADC2 analog inputs Channel16 and Channel17 are internally connected to  $V_{SS}$ .*

*ADC3 analog inputs Channel9, Channel14, Channel15, Channel16 and Channel17 are connected to  $V_{SS}$ .*

### 11.12.3 ADC control register 2 (ADC\_CR2)

Address offset: 0x08

Reset value: 0x0000 0000

31	30	29	28	27	26	25	24	23	22	21	20	19	18	17	16
Reserved								TSVRE FE	SWSTA RT	JSWST ART	EXTTR IG	EXTSEL[2:0]			Res.
Res.								rw	rw	rw	rw	rw	rw	rw	
15	14	13	12	11	10	9	8	7	6	5	4	3	2	1	0
JEXTT RIG	JEXTSEL[2:0]			ALIGN	Reserved	DMA	Reserved				RST CAL	CAL	CONT	ADON	
rw	rw	rw	rw	rw	Res.	rw	Res.				rw	rw	rw	rw	

Bits 31:24 Reserved, must be kept cleared.

Bit 23 **TSVREFE**: Temperature sensor and  $V_{REFINT}$  enable

This bit is set and cleared by software to enable/disable the temperature sensor and  $V_{REFINT}$  channel. In devices with dual ADCs this bit is present only in ADC1.

0: Temperature sensor and  $V_{REFINT}$  channel disabled

1: Temperature sensor and  $V_{REFINT}$  channel enabled

Bit 22 **SWSTART**: Start conversion of regular channels

This bit is set by software to start conversion and cleared by hardware as soon as conversion starts. It starts a conversion of a group of regular channels if SWSTART is selected as trigger event by the EXTSEL[2:0] bits.

0: Reset state

1: Starts conversion of regular channels

Bit 21 **JSWSTART**: Start conversion of injected channels

This bit is set by software and cleared by software or by hardware as soon as the conversion starts. It starts a conversion of a group of injected channels (if JSWSTART is selected as trigger event by the JEXTSEL[2:0] bits).

0: Reset state

1: Starts conversion of injected channels

Bit 20 **EXTTRIG**: External trigger conversion mode for regular channels

This bit is set and cleared by software to enable/disable the external trigger used to start conversion of a regular channel group.

0: Conversion on external event disabled

1: Conversion on external event enabled

Bits 19:17 **EXTSEL[2:0]**: External event select for regular group

These bits select the external event used to trigger the start of conversion of a regular group:

For ADC1 and ADC2, the assigned triggers are:

000: Timer 1 CC1 event

001: Timer 1 CC2 event

010: Timer 1 CC3 event

011: Timer 2 CC2 event

100: Timer 3 TRGO event

101: Timer 4 CC4 event

110: EXTI line11/TIM8\_TRGO event (TIM8\_TRGO is available only in high-density and XL-density devices)

111: SWSTART

For ADC3, the assigned triggers are:

000: Timer 3 CC1 event

001: Timer 2 CC3 event

010: Timer 1 CC3 event

011: Timer 8 CC1 event

100: Timer 8 TRGO event

101: Timer 5 CC1 event

110: Timer 5 CC3 event

111: SWSTART

Bit 16 Reserved, must be kept cleared.

Bit 15 **JEXTTRIG**: External trigger conversion mode for injected channels

This bit is set and cleared by software to enable/disable the external trigger used to start conversion of an injected channel group.

0: Conversion on external event disabled

1: Conversion on external event enabled

Bits 14:12 **JEXTSEL[2:0]**: External event select for injected group

These bits select the external event used to trigger the start of conversion of an injected group:

For ADC1 and ADC2 the assigned triggers are:

000: Timer 1 TRGO event

001: Timer 1 CC4 event

010: Timer 2 TRGO event

011: Timer 2 CC1 event

100: Timer 3 CC4 event

101: Timer 4 TRGO event

110: EXTI line15/TIM8\_CC4 event (TIM8\_CC4 is available only in high-density and XL-density devices)

111: JSWSTART

For ADC3 the assigned triggers are:

000: Timer 1 TRGO event

001: Timer 1 CC4 event

010: Timer 4 CC3 event

011: Timer 8 CC2 event

100: Timer 8 CC4 event

101: Timer 5 TRGO event

110: Timer 5 CC4 event

111: JSWSTART

Bit 11 **ALIGN**: Data alignment

This bit is set and cleared by software. Refer to [Figure 31](#) and [Figure 32](#).

0: Right Alignment

1: Left Alignment

Bits 10:9 Reserved, must be kept cleared.

Bit 8 **DMA**: Direct memory access mode

This bit is set and cleared by software. Refer to the DMA controller chapter for more details.

0: DMA mode disabled

1: DMA mode enabled

Only ADC1 and ADC3 can generate a DMA request.

Bits 7:4 Reserved, must be kept cleared.

Bit 3 **RSTCAL**: Reset calibration

This bit is set by software and cleared by hardware. It is cleared after the calibration registers are initialized.

0: Calibration register initialized.

1: Initialize calibration register.

*Note: If RSTCAL is set when conversion is ongoing, additional cycles are required to clear the calibration registers.*

Bit 2 **CAL**: A/D Calibration

This bit is set by software to start the calibration. It is reset by hardware after calibration is complete.

0: Calibration completed

1: Enable calibration



Bit 1 **CONT**: Continuous conversion

This bit is set and cleared by software. If set conversion takes place continuously till this bit is reset.

- 0: Single conversion mode
- 1: Continuous conversion mode

Bit 0 **ADON**: A/D converter ON / OFF

This bit is set and cleared by software. If this bit holds a value of zero and a 1 is written to it then it wakes up the ADC from Power Down state.

Conversion starts when this bit holds a value of 1 and a 1 is written to it. The application should allow a delay of  $t_{STAB}$  between power up and start of conversion. Refer to [Figure 27](#).

- 0: Disable ADC conversion/calibration and go to power down mode.
- 1: Enable ADC and to start conversion

*Note: If any other bit in this register apart from ADON is changed at the same time, then conversion is not triggered. This is to prevent triggering an erroneous conversion.*

### 11.12.4 ADC sample time register 1 (ADC\_SMPR1)

Address offset: 0x0C

Reset value: 0x0000 0000

31	30	29	28	27	26	25	24	23	22	21	20	19	18	17	16
Reserved								SMP17[2:0]			SMP16[2:0]			SMP15[2:1]	
Res.								rw	rw	rw	rw	rw	rw	rw	rw
15	14	13	12	11	10	9	8	7	6	5	4	3	2	1	0
SMP15_0	SMP14[2:0]			SMP13[2:0]			SMP12[2:0]			SMP11[2:0]			SMP10[2:0]		
rw	rw	rw	rw	rw	rw	rw	rw	rw	rw	rw	rw	rw	rw	rw	rw

Bits 31:24 Reserved, must be kept cleared.

Bits 23:0 **SMPx[2:0]**: Channel x Sample time selection

These bits are written by software to select the sample time individually for each channel. During sample cycles channel selection bits must remain unchanged.

- 000: 1.5 cycles
- 001: 7.5 cycles
- 010: 13.5 cycles
- 011: 28.5 cycles
- 100: 41.5 cycles
- 101: 55.5 cycles
- 110: 71.5 cycles
- 111: 239.5 cycles

*Note: ADC1 analog Channel16 and Channel 17 are internally connected to the temperature sensor and to  $V_{REFINT}$  respectively.*

*ADC2 analog input Channel16 and Channel17 are internally connected to  $V_{SS}$ .*

*ADC3 analog inputs Channel14, Channel15, Channel16 and Channel17 are connected to  $V_{SS}$ .*

### 11.12.5 ADC sample time register 2 (ADC\_SMPR2)

Address offset: 0x10

Reset value: 0x0000 0000

31	30	29	28	27	26	25	24	23	22	21	20	19	18	17	16
Reserved		SMP9[2:0]			SMP8[2:0]			SMP7[2:0]			SMP6[2:0]			SMP5[2:1]	
Res.		rw	rw	rw	rw	rw	rw	rw	rw	rw	rw	rw	rw	rw	rw
15	14	13	12	11	10	9	8	7	6	5	4	3	2	1	0
SMP5_0	SMP4[2:0]			SMP3[2:0]			SMP2[2:0]			SMP1[2:0]			SMP0[2:0]		
rw	rw	rw	rw	rw	rw	rw	rw	rw	rw	rw	rw	rw	rw	rw	rw

Bits 31:30 Reserved, must be kept cleared.

Bits 29:0 **SMPx[2:0]**: Channel x Sample time selection

These bits are written by software to select the sample time individually for each channel. During sample cycles channel selection bits must remain unchanged.

- 000: 1.5 cycles
- 001: 7.5 cycles
- 010: 13.5 cycles
- 011: 28.5 cycles
- 100: 41.5 cycles
- 101: 55.5 cycles
- 110: 71.5 cycles
- 111: 239.5 cycles

Note: ADC3 analog input Channel9 is connected to V<sub>SS</sub>.

### 11.12.6 ADC injected channel data offset register x (ADC\_JOFRx)(x=1..4)

Address offset: 0x14-0x20

Reset value: 0x0000 0000

31	30	29	28	27	26	25	24	23	22	21	20	19	18	17	16	
Reserved																
15	14	13	12	11	10	9	8	7	6	5	4	3	2	1	0	
Reserved				JOFFSETx[11:0]												
Res.				rw	rw	rw	rw	rw	rw	rw	rw	rw	rw	rw	rw	rw

Bits 31:12 Reserved, must be kept cleared.

Bits 11:0 **JOFFSETx[11:0]**: Data offset for injected channel x

These bits are written by software to define the offset to be subtracted from the raw converted data when converting injected channels. The conversion result can be read from in the ADC\_JDRx registers.

### 11.12.7 ADC watchdog high threshold register (ADC\_HTR)

Address offset: 0x24

Reset value: 0x0000 0FFF

31	30	29	28	27	26	25	24	23	22	21	20	19	18	17	16
Reserved															
15	14	13	12	11	10	9	8	7	6	5	4	3	2	1	0
Reserved				HT[11:0]											
				rw	rw	rw	rw	rw	rw	rw	rw	rw	rw	rw	rw

Bits 31:12 Reserved, must be kept cleared.

Bits 11:0 **HT[11:0]**: Analog watchdog high threshold

These bits are written by software to define the high threshold for the analog watchdog.

### 11.12.8 ADC watchdog low threshold register (ADC\_LTR)

Address offset: 0x28

Reset value: 0x0000 0000

31	30	29	28	27	26	25	24	23	22	21	20	19	18	17	16
Reserved															
15	14	13	12	11	10	9	8	7	6	5	4	3	2	1	0
Reserved				LT[11:0]											
Res				rw	rw	rw	rw	rw	rw	rw	rw	rw	rw	rw	rw

Bits 31:12 Reserved, must be kept cleared.

Bits 11:0 **LT[11:0]**: Analog watchdog low threshold

These bits are written by software to define the low threshold for the analog watchdog.

### 11.12.9 ADC regular sequence register 1 (ADC\_SQR1)

Address offset: 0x2C

Reset value: 0x0000 0000

31	30	29	28	27	26	25	24	23	22	21	20	19	18	17	16
Reserved								L[3:0]				SQ16[4:1]			
Res.								rw	rw	rw	rw	rw	rw	rw	rw
15	14	13	12	11	10	9	8	7	6	5	4	3	2	1	0
SQ16_0	SQ15[4:0]					SQ14[4:0]					SQ13[4:0]				
rw	rw	rw	rw	rw	rw	rw	rw	rw	rw	rw	rw	rw	rw	rw	rw

Bits 31:24 Reserved, must be kept cleared.

Bits 23:20 **L[3:0]**: Regular channel sequence length

These bits are written by software to define the total number of conversions in the regular channel conversion sequence.

0000: 1 conversion

0001: 2 conversions

.....

1111: 16 conversions

Bits 19:15 **SQ16[4:0]**: 16th conversion in regular sequence

These bits are written by software with the channel number (0..17) assigned as the 16th in the conversion sequence.

Bits 14:10 **SQ15[4:0]**: 15th conversion in regular sequence

Bits 9:5 **SQ14[4:0]**: 14th conversion in regular sequence

Bits 4:0 **SQ13[4:0]**: 13th conversion in regular sequence

### 11.12.10 ADC regular sequence register 2 (ADC\_SQR2)

Address offset: 0x30

Reset value: 0x0000 0000

31	30	29	28	27	26	25	24	23	22	21	20	19	18	17	16
Reserved	SQ12[4:0]					SQ11[4:0]					SQ10[4:1]				
	rw	rw	rw	rw	rw	rw	rw	rw	rw	rw	rw	rw	rw	rw	rw
15	14	13	12	11	10	9	8	7	6	5	4	3	2	1	0
SQ10_0	SQ9[4:0]					SQ8[4:0]					SQ7[4:0]				
rw	rw	rw	rw	rw	rw	rw	rw	rw	rw	rw	rw	rw	rw	rw	rw

Bits 31:30 Reserved, must be kept cleared.

Bits 29:26 **SQ12[4:0]**: 12th conversion in regular sequence

These bits are written by software with the channel number (0..17) assigned as the 12th in the sequence to be converted.

Bits 24:20 **SQ11[4:0]**: 11th conversion in regular sequence

- Bits 19:15 **SQ10[4:0]**: 10th conversion in regular sequence
- Bits 14:10 **SQ9[4:0]**: 9th conversion in regular sequence
- Bits 9:5 **SQ8[4:0]**: 8th conversion in regular sequence
- Bits 4:0 **SQ7[4:0]**: 7th conversion in regular sequence

### 11.12.11 ADC regular sequence register 3 (ADC\_SQR3)

Address offset: 0x34

Reset value: 0x0000 0000

	31	30	29	28	27	26	25	24	23	22	21	20	19	18	17	16
	Reserved		SQ6[4:0]				SQ5[4:0]				SQ4[4:1]					
			rw	rw	rw	rw	rw	rw	rw	rw	rw	rw	rw	rw	rw	rw
	15	14	13	12	11	10	9	8	7	6	5	4	3	2	1	0
	SQ4_0	SQ3[4:0]				SQ2[4:0]				SQ1[4:0]						
	rw	rw	rw	rw	rw	rw	rw	rw	rw	rw	rw	rw	rw	rw	rw	rw

- Bits 31:30 Reserved, must be kept cleared.
- Bits 29:25 **SQ6[4:0]**: 6th conversion in regular sequence  
 These bits are written by software with the channel number (0..17) assigned as the 6th in the sequence to be converted.
- Bits 24:20 **SQ5[4:0]**: 5th conversion in regular sequence
- Bits 19:15 **SQ4[4:0]**: 4th conversion in regular sequence
- Bits 14:10 **SQ3[4:0]**: 3rd conversion in regular sequence
  - Bits 9:5 **SQ2[4:0]**: 2nd conversion in regular sequence
  - Bits 4:0 **SQ1[4:0]**: 1st conversion in regular sequence

### 11.12.12 ADC injected sequence register (ADC\_JSQR)

Address offset: 0x38

Reset value: 0x0000 0000

	31	30	29	28	27	26	25	24	23	22	21	20	19	18	17	16
Reserved											JL[1:0]		JSQ4[4:1]			
											rw	rw	rw	rw	rw	rw
15	14	13	12	11	10	9	8	7	6	5	4	3	2	1	0	
JSQ4_0		JSQ3[4:0]				JSQ2[4:0]				JSQ1[4:0]						
rw	rw	rw	rw	rw	rw	rw	rw	rw	rw	rw	rw	rw	rw	rw	rw	

Bits 31:22 Reserved, must be kept cleared.

Bits 21:20 **JL[1:0]**: Injected sequence length

These bits are written by software to define the total number of conversions in the injected channel conversion sequence.

- 00: 1 conversion
- 01: 2 conversions
- 10: 3 conversions
- 11: 4 conversions

Bits 19:15 **JSQ4[4:0]**: 4th conversion in injected sequence

These bits are written by software with the channel number (0..17) assigned as the 4th in the sequence to be converted.

*Note: Unlike a regular conversion sequence, if JL[1:0] length is less than four, the channels are converted in a sequence starting from (4-JL). Example: ADC\_JSQR[21:0] = 10 00011 00011 00111 00010 means that a scan conversion will convert the following channel sequence: 7, 3, 3. (not 2, 7, 3)*

Bits 14:10 **JSQ3[4:0]**: 3rd conversion in injected sequence

Bits 9:5 **JSQ2[4:0]**: 2nd conversion in injected sequence

Bits 4:0 **JSQ1[4:0]**: 1st conversion in injected sequence

### 11.12.13 ADC injected data register x (ADC\_JDRx) (x= 1..4)

Address offset: 0x3C - 0x48

Reset value: 0x0000 0000

	31	30	29	28	27	26	25	24	23	22	21	20	19	18	17	16
Reserved																
15	14	13	12	11	10	9	8	7	6	5	4	3	2	1	0	
JDATA[15:0]																
r	r	r	r	r	r	r	r	r	r	r	r	r	r	r	r	r

Bits 31:16 Reserved, must be kept cleared.

Bits 15:0 **JDATA[15:0]**: Injected data

These bits are read only. They contain the conversion result from injected channel x. The data is left or right-aligned as shown in [Figure 31](#) and [Figure 32](#).

### 11.12.14 ADC regular data register (ADC\_DR)

Address offset: 0x4C

Reset value: 0x0000 0000

31	30	29	28	27	26	25	24	23	22	21	20	19	18	17	16
ADC2DATA[15:0]															
r	r	r	r	r	r	r	r	r	r	r	r	r	r	r	r
15	14	13	12	11	10	9	8	7	6	5	4	3	2	1	0
DATA[15:0]															
r	r	r	r	r	r	r	r	r	r	r	r	r	r	r	r

Bits 31:16 **ADC2DATA[15:0]**: ADC2 data

In ADC1: In dual mode, these bits contain the regular data of ADC2. Refer to [Section 11.9: Dual ADC mode](#).

In ADC2 and ADC3: these bits are not used.

Bits 15:0 **DATA[15:0]**: Regular data

These bits are read only. They contain the conversion result from the regular channels. The data is left or right-aligned as shown in [Figure 31](#) and [Figure 32](#).

### 11.12.15 ADC register map

The following table summarizes the ADC registers.

**Table 75. ADC register map and reset values**

Offset	Register	31	30	29	28	27	26	25	24	23	22	21	20	19	18	17	16	15	14	13	12	11	10	9	8	7	6	5	4	3	2	1	0					
0x00	<b>ADC_SR</b>	Reserved																									STRT	JSTRT	JEOC	EOC	AWD							
	Reset value	0																									0	0	0	0								
0x04	<b>ADC_CR1</b>	Reserved										AWDEN	JAWDEN	Reserved	DUALMOD [3:0]			DISC NUM [2:0]		JDISCEN	DISCEN	JAUTO	AUTO	AWD SGL	SCAN	JEOC IE	AWDIE	EOCIE	AWDCH[4:0]									
	Reset value	0										0	0	0	0	0	0	0	0	0	0	0	0	0	0	0	0	0	0	0	0	0	0	0	0	0	0	0
0x08	<b>ADC_CR2</b>	Reserved										TSVREFE	SWSTART	JSWSTART	EXTTRIG	EXTSEL [2:0]			Reserved	JEXTTRIG	JEXTSEL [2:0]		ALIGN	Reserved	DMA	Reserved				RSTCAL	CAL	CONT	ADON					
	Reset value	0										0	0	0	0	0	0	0	0	0	0	0	0	0	0	0	0	0	0	0	0	0	0	0	0	0	0	0
0x0C	<b>ADC_SMPR1</b>	Sample time bits SMPx_x																																				
	Reset value	0																																				
0x10	<b>ADC_SMPR2</b>	Sample time bits SMPx_x																																				
	Reset value	0																																				
0x14	<b>ADC_JOFR1</b>	Reserved																				JOFFSET1[11:0]																
	Reset value	0																				0																
0x18	<b>ADC_JOFR2</b>	Reserved																				JOFFSET2[11:0]																
	Reset value	0																				0																

Table 75. ADC register map and reset values (continued)

Offset	Register	31	30	29	28	27	26	25	24	23	22	21	20	19	18	17	16	15	14	13	12	11	10	9	8	7	6	5	4	3	2	1	0																				
0x1C	ADC_JOFR3	Reserved																				JOFFSET3[11:0]																															
	Reset value																					0	0	0	0	0	0	0	0	0	0	0	0	0	0	0	0	0	0	0	0	0	0	0	0	0	0	0	0	0	0	0	
0x20	ADC_JOFR4	Reserved																				JOFFSET4[11:0]																															
	Reset value																					0	0	0	0	0	0	0	0	0	0	0	0	0	0	0	0	0	0	0	0	0	0	0	0	0	0	0	0	0	0	0	0
0x24	ADC_HTR	Reserved																				HT[11:0]																															
	Reset value																					0	0	0	0	0	0	0	0	0	0	0	0	0	0	0	0	0	0	0	0	0	0	0	0	0	0	0	0	0	0	0	0
0x28	ADC_LTR	Reserved																				LT[11:0]																															
	Reset value																					0	0	0	0	0	0	0	0	0	0	0	0	0	0	0	0	0	0	0	0	0	0	0	0	0	0	0	0	0	0	0	0
0x2C	ADC_SQR1	Reserved								L[3:0]			Regular channel sequence SQx_x bits																																								
	Reset value									0	0	0	0	0	0	0	0	0	0	0	0	0	0	0	0	0	0	0	0	0	0	0	0	0	0	0	0	0	0	0	0	0											
0x30	ADC_SQR2	Reserved	Regular channel sequence SQx_x bits																																																		
	Reset value		0	0	0	0	0	0	0	0	0	0	0	0	0	0	0	0	0	0	0	0	0	0	0	0	0	0	0	0	0	0	0	0	0	0	0																
0x34	ADC_SQR3	Reserved	Regular channel sequence SQx_x bits																																																		
	Reset value		0	0	0	0	0	0	0	0	0	0	0	0	0	0	0	0	0	0	0	0	0	0	0	0	0	0	0	0	0	0	0	0	0	0	0	0															
0x38	ADC_JSQR	Reserved								JL[1:0]		Injected channel sequence JSQx_x bits																																									
	Reset value									0	0	0	0	0	0	0	0	0	0	0	0	0	0	0	0	0	0	0	0	0	0	0	0	0	0	0	0	0	0	0	0	0											
0x3C	ADC_JDR1	Reserved															JDATA[15:0]																																				
	Reset value																0	0	0	0	0	0	0	0	0	0	0	0	0	0	0	0	0	0	0	0	0	0	0	0	0	0	0	0	0	0	0	0	0	0	0		
0x40	ADC_JDR2	Reserved															JDATA[15:0]																																				
	Reset value																0	0	0	0	0	0	0	0	0	0	0	0	0	0	0	0	0	0	0	0	0	0	0	0	0	0	0	0	0	0	0	0	0	0	0	0	
0x44	ADC_JDR3	Reserved															JDATA[15:0]																																				
	Reset value																0	0	0	0	0	0	0	0	0	0	0	0	0	0	0	0	0	0	0	0	0	0	0	0	0	0	0	0	0	0	0	0	0	0	0	0	0
0x48	ADC_JDR4	Reserved															JDATA[15:0]																																				
	Reset value																0	0	0	0	0	0	0	0	0	0	0	0	0	0	0	0	0	0	0	0	0	0	0	0	0	0	0	0	0	0	0	0	0	0	0	0	0
0x4C	ADC_DR	Reserved															Regular DATA[15:0]																																				
	Reset value																0	0	0	0	0	0	0	0	0	0	0	0	0	0	0	0	0	0	0	0	0	0	0	0	0	0	0	0	0	0	0	0	0	0	0	0	0

Refer to [Table 1 on page 44](#) for the register boundary addresses.



## 12 Digital-to-analog converter (DAC)

**Low-density devices** are STM32F101xx, STM32F102xx and STM32F103xx microcontrollers where the Flash memory density ranges between 16 and 32 Kbytes.

**Medium-density devices** are STM32F101xx, STM32F102xx and STM32F103xx microcontrollers where the Flash memory density ranges between 64 and 128 Kbytes.

**High-density devices** are STM32F101xx and STM32F103xx microcontrollers where the Flash memory density ranges between 256 and 512 Kbytes.

**XL-density devices** are STM32F101xx and STM32F103xx microcontrollers where the Flash memory density ranges between 768 Kbytes and 1 Mbyte.

**Connectivity line devices** are STM32F105xx and STM32F107xx microcontrollers.

This section applies to connectivity line, high-density and XL-density STM32F101xx and STM32F103xx devices only.

### 12.1 DAC introduction

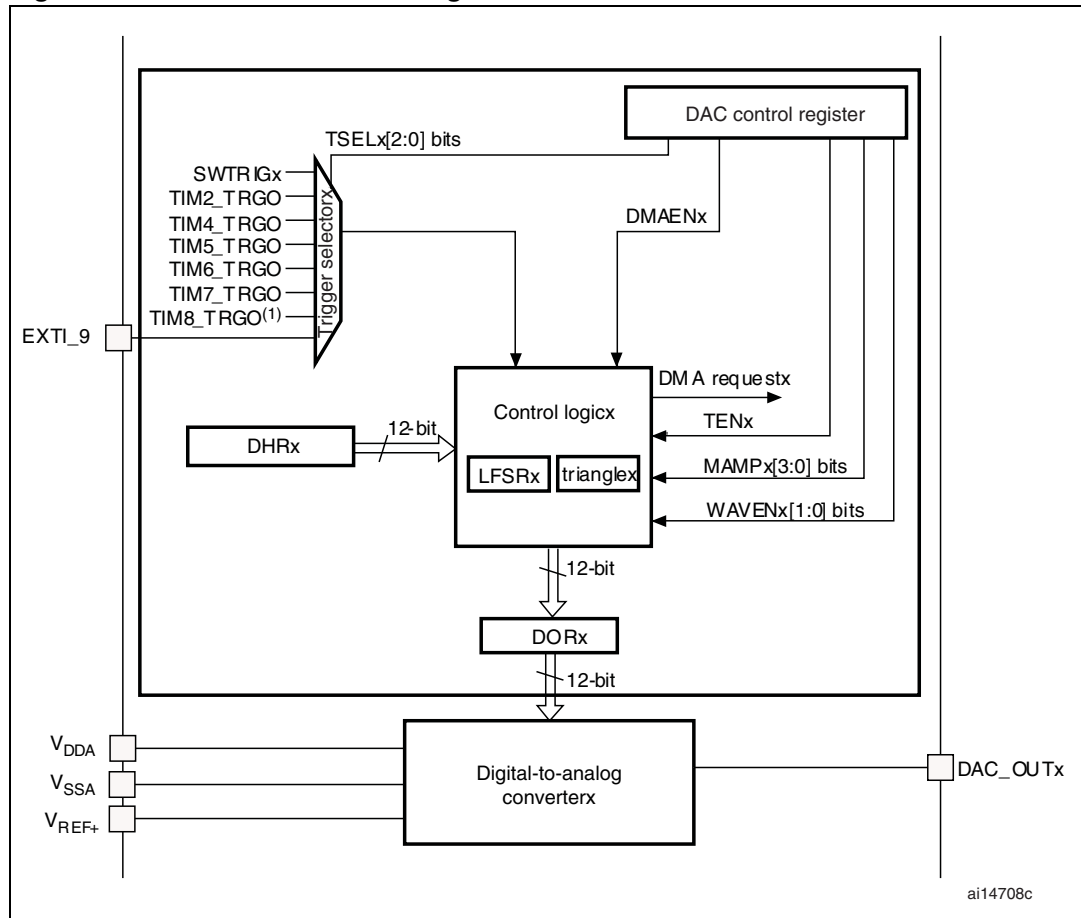
The DAC module is a 12-bit, voltage output digital-to-analog converter. The DAC can be configured in 8- or 12-bit mode and may be used in conjunction with the DMA controller. In 12-bit mode, the data could be left- or right-aligned. The DAC has two output channels, each with its own converter. In dual DAC channel mode, conversions could be done independently or simultaneously when both channels are grouped together for synchronous update operation. An input reference pin  $V_{REF+}$  is available for better resolution.

### 12.2 DAC main features

- Two DAC converters: one output channel each
- Left or right data alignment in 12-bit mode
- Synchronized update capability
- Noise-wave generation
- Triangular-wave generation
- Dual DAC channel independent or simultaneous conversions
- DMA capability for each channel
- External triggers for conversion
- Input voltage reference  $V_{REF+}$

The block diagram of a DAC channel is shown in [Figure 44](#) and the pin description is given in [Table 76](#).

Figure 44. DAC channel block diagram



1. In connectivity line devices, the TIM8\_TRGO trigger is replaced by TIM3\_TRGO .

Table 76. DAC pins

Name	Signal type	Remarks
V <sub>REF+</sub>	Input, analog reference positive	The higher/positive reference voltage for the DAC, $2.4\text{ V} \leq V_{\text{REF}+} \leq V_{\text{DDA}} (3.3\text{ V})$
V <sub>DDA</sub>	Input, analog supply	Analog power supply
V <sub>SSA</sub>	Input, analog supply ground	Ground for analog power supply
DAC_OUTx	Analog output signal	DAC channelx analog output

**Note:** Once the DAC channelx is enabled, the corresponding GPIO pin (PA4 or PA5) is automatically connected to the analog converter output (DAC\_OUTx). In order to avoid parasitic consumption, the PA4 or PA5 pin should first be configured to analog (AIN).

## 12.3 DAC functional description

### 12.3.1 DAC channel enable

Each DAC channel can be powered on by setting its corresponding ENx bit in the DAC\_CR register. The DAC channel is then enabled after a startup time  $t_{WAKEUP}$ .

*Note:* The ENx bit enables the analog DAC Channelx macrocell only. The DAC Channelx digital interface is enabled even if the ENx bit is reset.

### 12.3.2 DAC output buffer enable

The DAC integrates two output buffers that can be used to reduce the output impedance, and to drive external loads directly without having to add an external operational amplifier. Each DAC channel output buffer can be enabled and disabled using the corresponding BOFFx bit in the DAC\_CR register.

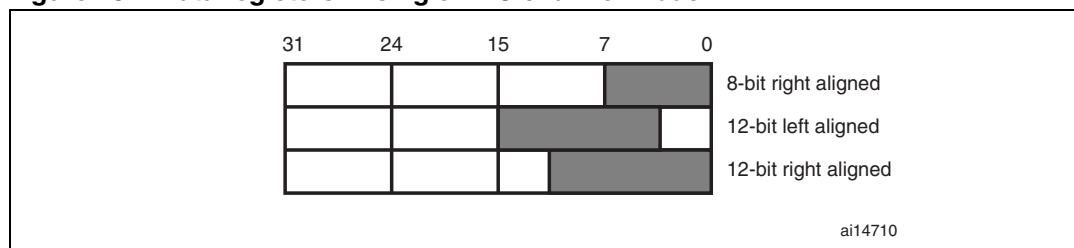
### 12.3.3 DAC data format

Depending on the selected configuration mode, the data has to be written in the specified register as described below:

- Single DAC channelx, there are three possibilities:
  - 8-bit right alignment: user has to load data into DAC\_DHR8Rx [7:0] bits (stored into DHRx[11:4] bits)
  - 12-bit left alignment: user has to load data into DAC\_DHR12Lx [15:4] bits (stored into DHRx[11:0] bits)
  - 12-bit right alignment: user has to load data into DAC\_DHR12Rx [11:0] bits (stored into DHRx[11:0] bits)

Depending on the loaded DAC\_DHRyyyx register, the data written by the user will be shifted and stored into the DHRx (Data Holding Registerx, that are internal non-memory-mapped registers). The DHRx register will then be loaded into the DORx register either automatically, by software trigger or by an external event trigger.

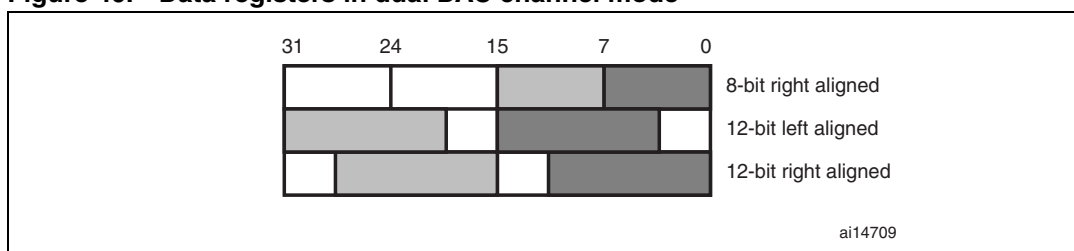
Figure 45. Data registers in single DAC channel mode



- Dual DAC channels, there are three possibilities:
  - 8-bit right alignment: data for DAC channel1 to be loaded into DAC\_DHR8RD [7:0] bits (stored into DHR1[11:4] bits) and data for DAC channel2 to be loaded into DAC\_DHR8RD [15:8] bits (stored into DHR2[11:4] bits)
  - 12-bit left alignment: data for DAC channel1 to be loaded into DAC\_DHR12LD [15:4] bits (stored into DHR1[11:0] bits) and data for DAC channel2 to be loaded into DAC\_DHR12LD [31:20] bits (stored into DHR2[11:0] bits)
  - 12-bit right alignment: data for DAC channel1 to be loaded into DAC\_DHR12RD [11:0] bits (stored into DHR1[11:0] bits) and data for DAC channel2 to be loaded into DAC\_DHR12LD [27:16] bits (stored into DHR2[11:0] bits)

Depending on the loaded DAC\_DHRyyyD register, the data written by the user will be shifted and stored into the DHR1 and DHR2 (Data Holding Registers, that are internal non-memory-mapped registers). The DHR1 and DHR2 registers will then be loaded into the DOR1 and DOR2 registers, respectively, either automatically, by software trigger or by an external event trigger.

Figure 46. Data registers in dual DAC channel mode



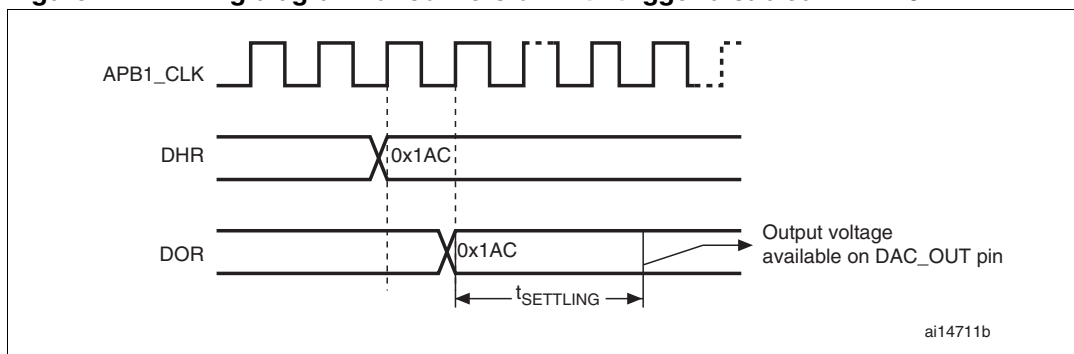
### 12.3.4 DAC conversion

The DAC\_DORx cannot be written directly and any data transfer to the DAC channelx must be performed by loading the DAC\_DHRx register (write on DAC\_DHR8Rx, DAC\_DHR12Lx, DAC\_DHR12Rx, DAC\_DHR8RD, DAC\_DHR12LD or DAC\_DHR12RD).

Data stored into the DAC\_DHRx register are automatically transferred to the DAC\_DORx register after one APB1 clock cycle, if no hardware trigger is selected (TENx bit in DAC\_CR register is reset). However, when a hardware trigger is selected (TENx bit in DAC\_CR register is set) and a trigger occurs, the transfer is performed three APB1 clock cycles later.

When DAC\_DORx is loaded with the DAC\_DHRx contents, the analog output voltage becomes available after a time of  $t_{SETTLING}$  that depends on the power supply voltage and the analog output load.

Figure 47. Timing diagram for conversion with trigger disabled TEN = 0



### 12.3.5 DAC output voltage

Digital inputs are converted to output voltages on a linear conversion between 0 and  $V_{REF+}$ . The analog output voltages on each DAC channel pin are determined by the following equation:

$$DAC_{output} = V_{REF} \times \frac{DOR}{4095}$$

### 12.3.6 DAC trigger selection

If the  $TENx$  control bit is set, conversion can then be triggered by an external event (timer counter, external interrupt line). The  $TSELx[2:0]$  control bits determine which out of 8 possible events will trigger conversion as shown in [Table 77](#).

Table 77. External triggers

Source	Type	TSEL[2:0]
Timer 6 TRGO event	Internal signal from on-chip timers	000
Timer 3 TRGO event in connectivity line devices or Timer 8 TRGO in high-density and XL-density devices		001
Timer 7 TRGO event		010
Timer 5 TRGO event		011
Timer 2 TRGO event		100
Timer 4 TRGO event		101
EXTI line9	External pin	110
SWTRIG	Software control bit	111

Each time a DAC interface detects a rising edge on the selected timer TRGO output, or on the selected external interrupt line 9, the last data stored into the  $DAC\_DHRx$  register is transferred into the  $DAC\_DORx$  register. The  $DAC\_DORx$  register is updated three APB1 cycles after the trigger occurs.

If the software trigger is selected, the conversion starts once the SWTRIG bit is set. SWTRIG is reset by hardware once the  $DAC\_DORx$  register has been loaded with the  $DAC\_DHRx$  register contents.

- Note:
- 1  $TSELx[2:0]$  bit cannot be changed when the  $ENx$  bit is set.
  - 2 When software trigger is selected, it takes only one APB1 clock cycle for DAC\_DHRx-to-DAC\_DORx register transfer.

### 12.3.7 DMA request

Each DAC channel has a DMA capability. Two DMA channels are used to service DAC channel DMA requests.

A DAC DMA request is generated when an external trigger (but not a software trigger) occurs while the  $DMAENx$  bit is set. The value of the DAC\_DHRx register is then transferred to the DAC\_DORx register.

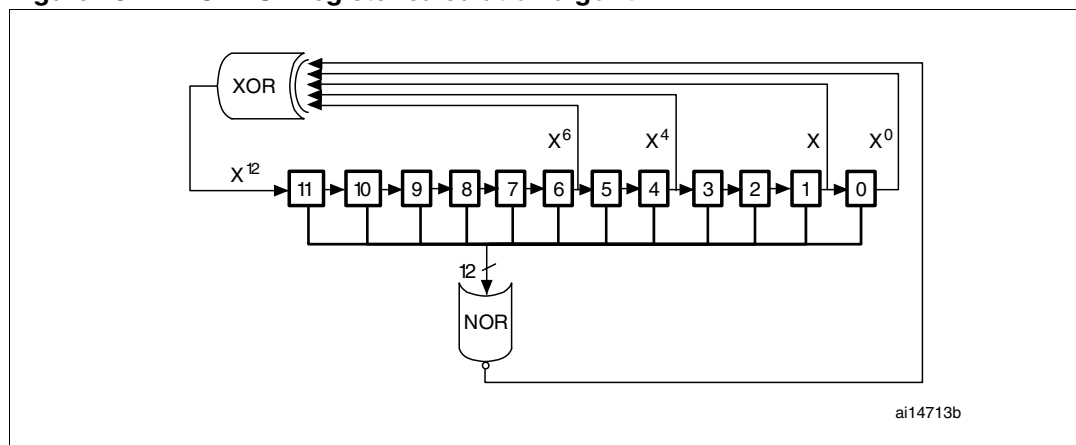
In dual mode, if both  $DMAENx$  bits are set, two DMA requests are generated. If only one DMA request is needed, you should set only the corresponding  $DMAENx$  bit. In this way, the application can manage both DAC channels in dual mode by using one DMA request and a unique DMA channel.

The DAC DMA request is not queued so that if a second external trigger arrives before the acknowledgement of the last request, then the new request will not be serviced and no error is reported

### 12.3.8 Noise generation

In order to generate a variable-amplitude pseudonoise, a Linear Feedback Shift Register is available. The DAC noise generation is selected by setting  $WAVEx[1:0]$  to "01". The preloaded value in the LFSR is 0xAAA. This register is updated, three APB1 clock cycles after each trigger event, following a specific calculation algorithm.

**Figure 48. DAC LFSR register calculation algorithm**

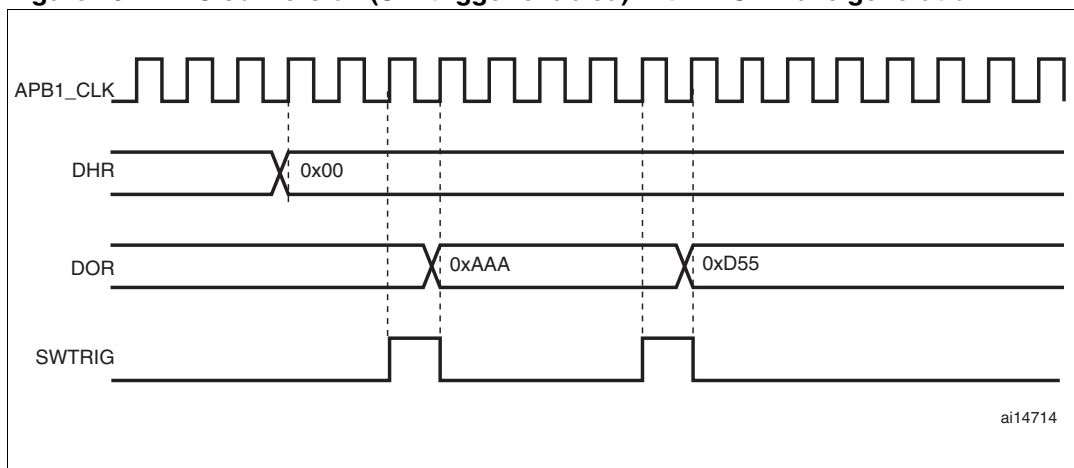


The LFSR value, that may be masked partially or totally by means of the  $MAMPx[3:0]$  bits in the DAC\_CR register, is added up to the DAC\_DHRx contents without overflow and this value is then stored into the DAC\_DORx register.

If LFSR is 0x0000, a '1' is injected into it (antilock-up mechanism).

It is possible to reset LFSR wave generation by resetting the  $WAVEx[1:0]$  bits.

**Figure 49. DAC conversion (SW trigger enabled) with LFSR wave generation**



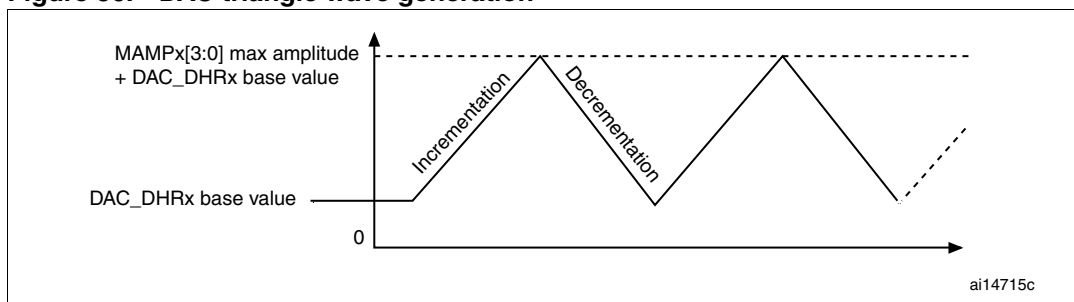
*Note:* DAC trigger must be enabled for noise generation, by setting the TENx bit in the DAC\_CR register.

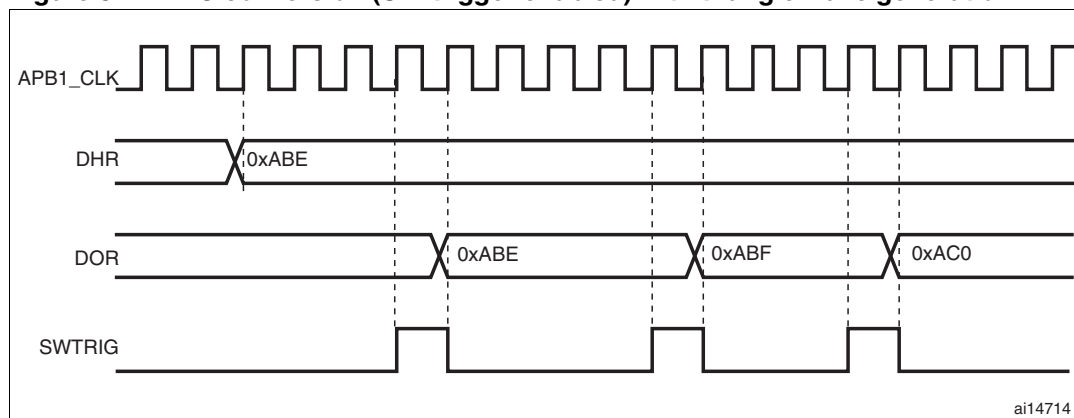
### 12.3.9 Triangle-wave generation

It is possible to add a small-amplitude triangular waveform on a DC or slowly varying signal. DAC triangle-wave generation is selected by setting WAVEx[1:0] to “10”. The amplitude is configured through the MAMPx[3:0] bits in the DAC\_CR register. An internal triangle counter is incremented three APB1 clock cycles after each trigger event. The value of this counter is then added to the DAC\_DHRx register without overflow and the sum is stored into the DAC\_DORx register. The triangle counter is incremented while it is less than the maximum amplitude defined by the MAMPx[3:0] bits. Once the configured amplitude is reached, the counter is decremented down to 0, then incremented again and so on.

It is possible to reset triangle wave generation by resetting WAVEx[1:0] bits.

**Figure 50. DAC triangle wave generation**



**Figure 51. DAC conversion (SW trigger enabled) with triangle wave generation**

- Note:*
- 1 DAC trigger must be enabled for noise generation, by setting the *TENx* bit in the *DAC\_CR* register.
  - 2 *MAMPx[3:0]* bits must be configured before enabling the DAC, otherwise they cannot be changed.

## 12.4 Dual DAC channel conversion

To efficiently use the bus bandwidth in applications that require the two DAC channels at the same time, three dual registers are implemented: DHR8RD, DHR12RD and DHR12LD. A unique register access is then required to drive both DAC channels at the same time.

Eleven possible conversion modes are possible using the two DAC channels and these dual registers. All the conversion modes can nevertheless be obtained using separate DHRx registers if needed.

All modes are described in the paragraphs below.

### 12.4.1 Independent trigger without wave generation

To configure the DAC in this conversion mode, the following sequence is required:

- Set the two DAC channel trigger enable bits *TEN1* and *TEN2*
- Configure different trigger sources by setting different values in the *TSEL1[2:0]* and *TSEL2[2:0]* bits
- Load the dual DAC channel data into the desired DHR register (*DAC\_DHR12RD*, *DAC\_DHR12LD* or *DAC\_DHR8RD*)

When a DAC channel1 trigger arrives, the DHR1 register is transferred into *DAC\_DOR1* (three APB1 clock cycles later).

When a DAC channel2 trigger arrives, the DHR2 register is transferred into *DAC\_DOR2* (three APB1 clock cycles later).



### 12.4.2 Independent trigger with same LFSR generation

To configure the DAC in this conversion mode, the following sequence is required:

- Set the two DAC channel trigger enable bits TEN1 and TEN2
- Configure different trigger sources by setting different values in the TSEL1[2:0] and TSEL2[2:0] bits
- Configure the two DAC channel WAVEx[1:0] bits as “01” and the same LFSR mask value in the MAMPx[3:0] bits
- Load the dual DAC channel data into the desired DHR register (DHR12RD, DHR12LD or DHR8RD)

When a DAC channel1 trigger arrives, the LFSR1 counter, with the same mask, is added to the DHR1 register and the sum is transferred into DAC\_DOR1 (three APB1 clock cycles later). Then the LFSR1 counter is updated.

When a DAC channel2 trigger arrives, the LFSR2 counter, with the same mask, is added to the DHR2 register and the sum is transferred into DAC\_DOR2 (three APB1 clock cycles later). Then the LFSR2 counter is updated.

### 12.4.3 Independent trigger with different LFSR generation

To configure the DAC in this conversion mode, the following sequence is required:

- Set the two DAC channel trigger enable bits TEN1 and TEN2
- Configure different trigger sources by setting different values in the TSEL1[2:0] and TSEL2[2:0] bits
- Configure the two DAC channel WAVEx[1:0] bits as “01” and set different LFSR mask values in the MAMP1[3:0] and MAMP2[3:0] bits
- Load the dual DAC channel data into the desired DHR register (DAC\_DHR12RD, DAC\_DHR12LD or DAC\_DHR8RD)

When a DAC channel1 trigger arrives, the LFSR1 counter, with the mask configured by MAMP1[3:0], is added to the DHR1 register and the sum is transferred into DAC\_DOR1 (three APB1 clock cycles later). Then the LFSR1 counter is updated.

When a DAC channel2 trigger arrives, the LFSR2 counter, with the mask configured by MAMP2[3:0], is added to the DHR2 register and the sum is transferred into DAC\_DOR2 (three APB1 clock cycles later). Then the LFSR2 counter is updated.

### 12.4.4 Independent trigger with same triangle generation

To configure the DAC in this conversion mode, the following sequence is required:

- Set the two DAC channel trigger enable bits TEN1 and TEN2
- Configure different trigger sources by setting different values in the TSEL1[2:0] and TSEL2[2:0] bits
- Configure the two DAC channel WAVEx[1:0] bits as “1x” and the same maximum amplitude value in the MAMPx[3:0] bits
- Load the dual DAC channel data into the desired DHR register (DAC\_DHR12RD, DAC\_DHR12LD or DAC\_DHR8RD)

When a DAC channel1 trigger arrives, the DAC channel1 triangle counter, with the same triangle amplitude, is added to the DHR1 register and the sum is transferred into

DAC\_DOR1 (three APB1 clock cycles later). The DAC channel1 triangle counter is then updated.

When a DAC channel2 trigger arrives, the DAC channel2 triangle counter, with the same triangle amplitude, is added to the DHR2 register and the sum is transferred into DAC\_DOR2 (three APB1 clock cycles later). The DAC channel2 triangle counter is then updated.

#### 12.4.5 Independent trigger with different triangle generation

To configure the DAC in this conversion mode, the following sequence is required:

- Set the two DAC channel trigger enable bits TEN1 and TEN2
- Configure different trigger sources by setting different values in the TSEL1[2:0] and TSEL2[2:0] bits
- Configure the two DAC channel WAVEx[1:0] bits as “1x” and set different maximum amplitude values in the MAMP1[3:0] and MAMP2[3:0] bits
- Load the dual DAC channel data into the desired DHR register (DAC\_DHR12RD, DAC\_DHR12LD or DAC\_DHR8RD)

When a DAC channel1 trigger arrives, the DAC channel1 triangle counter, with a triangle amplitude configured by MAMP1[3:0], is added to the DHR1 register and the sum is transferred into DAC\_DOR1 (three APB1 clock cycles later). The DAC channel1 triangle counter is then updated.

When a DAC channel2 trigger arrives, the DAC channel2 triangle counter, with a triangle amplitude configured by MAMP2[3:0], is added to the DHR2 register part and the sum is transferred into DAC\_DOR2 (three APB1 clock cycles later). The DAC channel2 triangle counter is then updated.

#### 12.4.6 Simultaneous software start

To configure the DAC in this conversion mode, the following sequence is required:

- Load the dual DAC channel data to the desired DHR register (DAC\_DHR12RD, DAC\_DHR12LD or DAC\_DHR8RD)

In this configuration, one APB1 clock cycle later, the DHR1 and DHR2 registers are transferred into DAC\_DOR1 and DAC\_DOR2, respectively.

#### 12.4.7 Simultaneous trigger without wave generation

To configure the DAC in this conversion mode, the following sequence is required:

- Set the two DAC channel trigger enable bits TEN1 and TEN2
- Configure the same trigger source for both DAC channels by setting the same value in the TSEL1[2:0] and TSEL2[2:0] bits
- Load the dual DAC channel data to the desired DHR register (DAC\_DHR12RD, DAC\_DHR12LD or DAC\_DHR8RD)

When a trigger arrives, the DHR1 and DHR2 registers are transferred into DAC\_DOR1 and DAC\_DOR2, respectively (after three APB1 clock cycles).

### 12.4.8 Simultaneous trigger with same LFSR generation

To configure the DAC in this conversion mode, the following sequence is required:

- Set the two DAC channel trigger enable bits TEN1 and TEN2
- Configure the same trigger source for both DAC channels by setting the same value in the TSEL1[2:0] and TSEL2[2:0] bits
- Configure the two DAC channel WAVEx[1:0] bits as “01” and the same LFSR mask value in the MAMPx[3:0] bits
- Load the dual DAC channel data to the desired DHR register (DHR12RD, DHR12LD or DHR8RD)

When a trigger arrives, the LFSR1 counter, with the same mask, is added to the DHR1 register and the sum is transferred into DAC\_DOR1 (three APB1 clock cycles later). The LFSR1 counter is then updated. At the same time, the LFSR2 counter, with the same mask, is added to the DHR2 register and the sum is transferred into DAC\_DOR2 (three APB1 clock cycles later). The LFSR2 counter is then updated.

### 12.4.9 Simultaneous trigger with different LFSR generation

To configure the DAC in this conversion mode, the following sequence is required:

- Set the two DAC channel trigger enable bits TEN1 and TEN2
- Configure the same trigger source for both DAC channels by setting the same value in the TSEL1[2:0] and TSEL2[2:0] bits
- Configure the two DAC channel WAVEx[1:0] bits as “01” and set different LFSR masks values using the MAMP1[3:0] and MAMP2[3:0] bits
- Load the dual DAC channel data into the desired DHR register (DAC\_DHR12RD, DAC\_DHR12LD or DAC\_DHR8RD)

When a trigger arrives, the LFSR1 counter, with the mask configured by MAMP1[3:0], is added to the DHR1 register and the sum is transferred into DAC\_DOR1 (three APB1 clock cycles later). The LFSR1 counter is then updated.

At the same time, the LFSR2 counter, with the mask configured by MAMP2[3:0], is added to the DHR2 register and the sum is transferred into DAC\_DOR2 (three APB1 clock cycles later). The LFSR2 counter is then updated.

### 12.4.10 Simultaneous trigger with same triangle generation

To configure the DAC in this conversion mode, the following sequence is required:

- Set the two DAC channel trigger enable bits TEN1 and TEN2
- Configure the same trigger source for both DAC channels by setting the same value in the TSEL1[2:0] and TSEL2[2:0] bits
- Configure the two DAC channel WAVEx[1:0] bits as “1x” and the same maximum amplitude value using the MAMPx[3:0] bits
- Load the dual DAC channel data into the desired DHR register (DAC\_DHR12RD, DAC\_DHR12LD or DAC\_DHR8RD)

When a trigger arrives, the DAC channel1 triangle counter, with the same triangle amplitude, is added to the DHR1 register and the sum is transferred into DAC\_DOR1 (three APB1 clock cycles later). The DAC channel1 triangle counter is then updated.

At the same time, the DAC channel2 triangle counter, with the same triangle amplitude, is

added to the DHR2 register and the sum is transferred into DAC\_DOR2 (three APB1 clock cycles later). The DAC channel2 triangle counter is then updated.

### 12.4.11 Simultaneous trigger with different triangle generation

To configure the DAC in this conversion mode, the following sequence is required:

- Set the two DAC channel trigger enable bits TEN1 and TEN2
- Configure the same trigger source for both DAC channels by setting the same value in the TSEL1[2:0] and TSEL2[2:0] bits
- Configure the two DAC channel WAVEx[1:0] bits as “1x” and set different maximum amplitude values in the MAMP1[3:0] and MAMP2[3:0] bits
- Load the dual DAC channel data into the desired DHR register (DAC\_DHR12RD, DAC\_DHR12LD or DAC\_DHR8RD)

When a trigger arrives, the DAC channel1 triangle counter, with a triangle amplitude configured by MAMP1[3:0], is added to the DHR1 register and the sum is transferred into DAC\_DOR1 (three APB1 clock cycles later). Then the DAC channel1 triangle counter is updated.

At the same time, the DAC channel2 triangle counter, with a triangle amplitude configured by MAMP2[3:0], is added to the DHR2 register and the sum is transferred into DAC\_DOR2 (three APB1 clock cycles later). Then the DAC channel2 triangle counter is updated.

## 12.5 DAC registers

The peripheral registers have to be accessed by words (32-bit).

### 12.5.1 DAC control register (DAC\_CR)

Address offset: 0x00

Reset value: 0x0000 0000

31	30	29	28	27	26	25	24	23	22	21	20	19	18	17	16
Reserved			DMA EN2	MAMP2[3:0]				WAVE2[1:0]		TSEL2[2:0]			TEN2	BOFF2	EN2
			rw	rw	rw	rw	rw	rw	rw	rw	rw	rw	rw	rw	rw
15	14	13	12	11	10	9	8	7	6	5	4	3	2	1	0
Reserved			DMA EN1	MAMP1[3:0]				WAVE1[1:0]		TSEL1[2:0]			TEN1	BOFF1	EN1
			rw	rw	rw	rw	rw	rw	rw	rw	rw	rw	rw	rw	rw

Bits 31:29 Reserved.

Bit 28 **DMAEN2**: DAC channel2 DMA enable

This bit is set and cleared by software.

0: DAC channel2 DMA mode disabled

1: DAC channel2 DMA mode enabled

Bit 27:24 **MAMP2[3:0]**: DAC channel2 mask/amplitude selector

These bits are written by software to select mask in wave generation mode or amplitude in triangle generation mode.

0000: Unmask bit0 of LFSR/ Triangle Amplitude equal to 1  
 0001: Unmask bits[1:0] of LFSR/ Triangle Amplitude equal to 3  
 0010: Unmask bits[2:0] of LFSR/ Triangle Amplitude equal to 7  
 0011: Unmask bits[3:0] of LFSR/ Triangle Amplitude equal to 15  
 0100: Unmask bits[4:0] of LFSR/ Triangle Amplitude equal to 31  
 0101: Unmask bits[5:0] of LFSR/ Triangle Amplitude equal to 63  
 0110: Unmask bits[6:0] of LFSR/ Triangle Amplitude equal to 127  
 0111: Unmask bits[7:0] of LFSR/ Triangle Amplitude equal to 255  
 1000: Unmask bits[8:0] of LFSR/ Triangle Amplitude equal to 511  
 1001: Unmask bits[9:0] of LFSR/ Triangle Amplitude equal to 1023  
 1010: Unmask bits[10:0] of LFSR/ Triangle Amplitude equal to 2047  
 ≥ 1011: Unmask bits[11:0] of LFSR/ Triangle Amplitude equal to 4095

Bit 23:22 **WAVE2[1:0]**: DAC channel2 noise/triangle wave generation enable

These bits are set/reset by software.

00: wave generation disabled  
 01: Noise wave generation enabled  
 1x: Triangle wave generation enabled

*Note: only used if bit TEN2 = 1 (DAC channel2 trigger enabled)*

Bits 21:19 **TSEL2[2:0]**: DAC channel2 trigger selection

These bits select the external event used to trigger DAC channel2

000: Timer 6 TRGO event  
 001: Timer 3 TRGO event in connectivity line devices, Timer 8 TRGO in high-density and XL-density devices  
 010: Timer 7 TRGO event  
 011: Timer 5 TRGO event  
 100: Timer 2 TRGO event  
 101: Timer 4 TRGO event  
 110: External line9  
 111: Software trigger

*Note: only used if bit TEN2 = 1 (DAC channel2 trigger enabled)*

Bit 18 **TEN2**: DAC channel2 trigger enable

This bit set and cleared by software to enable/disable DAC channel2 trigger

0: DAC channel2 trigger disabled and data written into DAC\_DHRx register is transferred one APB1 clock cycle later to the DAC\_DOR2 register.  
 1: DAC channel2 trigger enabled and data transfer from DAC\_DHRx register is transferred three APB1 clock cycles later to the DAC\_DOR2 register.

*Note: When software trigger is selected, it takes only one APB1 clock cycle for DAC\_DHRx to DAC\_DOR2 register transfer.*

Bit 17 **BOFF2**: DAC channel2 output buffer disable

This bit set and cleared by software to enable/disable DAC channel2 output buffer.

0: DAC channel2 output buffer enabled  
 1: DAC channel2 output buffer disabled

Bit 16 **EN2**: DAC channel2 enable

This bit set and cleared by software to enable/disable DAC channel2.

0: DAC channel2 disabled  
 1: DAC channel2 enabled

Bits 15:13 Reserved.

Bit 12 **DMAEN1**: DAC channel1 DMA enable

This bit is set and cleared by software.

0: DAC channel1 DMA mode disabled

1: DAC channel1 DMA mode enabled

Bits 11:8 **MAMP1[3:0]**: DAC channel1 mask/amplitude selector

These bits are written by software to select mask in wave generation mode or amplitude in triangle generation mode.

0000: Unmask bit0 of LFSR/ Triangle Amplitude equal to 1

0001: Unmask bits[1:0] of LFSR/ Triangle Amplitude equal to 3

0010: Unmask bits[2:0] of LFSR/ Triangle Amplitude equal to 7

0011: Unmask bits[3:0] of LFSR/ Triangle Amplitude equal to 15

0100: Unmask bits[4:0] of LFSR/ Triangle Amplitude equal to 31

0101: Unmask bits[5:0] of LFSR/ Triangle Amplitude equal to 63

0110: Unmask bits[6:0] of LFSR/ Triangle Amplitude equal to 127

0111: Unmask bits[7:0] of LFSR/ Triangle Amplitude equal to 255

1000: Unmask bits[8:0] of LFSR/ Triangle Amplitude equal to 511

1001: Unmask bits[9:0] of LFSR/ Triangle Amplitude equal to 1023

1010: Unmask bits[10:0] of LFSR/ Triangle Amplitude equal to 2047

≥ 1011: Unmask bits[11:0] of LFSR/ Triangle Amplitude equal to 4095

Bits 7:6 **WAVE1[1:0]**: DAC channel1 noise/triangle wave generation enable

These bits are set/reset by software.

00: wave generation disabled

01: Noise wave generation enabled

1x: Triangle wave generation enabled

**Note:** only used if bit *TEN1* = 1 (DAC channel1 trigger enabled)

Bits 5:3 **TSEL1[2:0]**: DAC channel1 trigger selection

These bits select the external event used to trigger DAC channel1

000: Timer 6 TRGO event

001: Timer 3 TRGO event in connectivity line devices, Timer 8 TRGO in high-density and XL-density devices

010: Timer 7 TRGO event

011: Timer 5 TRGO event

100: Timer 2 TRGO event

101: Timer 4 TRGO event

110: External line9

111: Software trigger

*Note: only used if bit *TEN1* = 1 (DAC channel1 trigger enabled)*

Bit 2 **TEN1**: DAC channel1 trigger enable

This bit set and cleared by software to enable/disable DAC channel1 trigger

0: DAC channel1 trigger disabled and data written into DAC\_DHRx register is transferred one APB1 clock cycle later to the DAC\_DOR1 register.

1: DAC channel1 trigger enabled and data transfer from DAC\_DHRx register is transferred three APB1 clock cycles later to the DAC\_DOR1 register.

*Note: When software trigger is selected, it takes only one APB1 clock cycle for DAC\_DHRx to DAC\_DOR1 register transfer.*

- Bit 1 **BOFF1**: DAC channel1 output buffer disable  
 This bit set and cleared by software to enable/disable DAC channel1 output buffer.  
 0: DAC channel1 output buffer enabled  
 1: DAC channel1 output buffer disabled
- Bit 0 **EN1**: DAC channel1 enable  
 This bit set and cleared by software to enable/disable DAC channel1.  
 0: DAC channel1 disabled  
 1: DAC channel1 enabled

### 12.5.2 DAC software trigger register (DAC\_SWTRIGR)

Address offset: 0x04

Reset value: 0x0000 0000

31	30	29	28	27	26	25	24	23	22	21	20	19	18	17	16
Reserved															
15	14	13	12	11	10	9	8	7	6	5	4	3	2	1	0
Reserved														SWTRIG2	SWTRIG1
														w	w

Bits 31:2 Reserved.

- Bit 1 **SWTRIG2**: DAC channel2 software trigger  
 This bit is set and cleared by software to enable/disable the software trigger.  
 0: Software trigger disabled  
 1: Software trigger enabled  
*Note: This bit is reset by hardware (one APB1 clock cycle later) once the DAC\_DHR2 register value is loaded to the DAC\_DOR2 register.*
- Bit 0 **SWTRIG1**: DAC channel1 software trigger  
 This bit is set and cleared by software to enable/disable the software trigger.  
 0: Software trigger disabled  
 1: Software trigger enabled  
*Note: This bit is reset by hardware (one APB1 clock cycle later) once the DAC\_DHR1 register value is loaded to the DAC\_DOR1 register.*

### 12.5.3 DAC channel1 12-bit right-aligned data holding register (DAC\_DHR12R1)

Address offset: 0x08

Reset value: 0x0000 0000

31	30	29	28	27	26	25	24	23	22	21	20	19	18	17	16	
Reserved																
15	14	13	12	11	10	9	8	7	6	5	4	3	2	1	0	
Reserved				DACC1DHR[11:0]												
				rw	rw	rw	rw	rw	rw	rw	rw	rw	rw	rw	rw	rw

Bits 31:12 Reserved.

Bit 11:0 **DACC1DHR[11:0]**: DAC channel1 12-bit right-aligned data

These bits are written by software which specify 12-bit data for DAC channel1.

### 12.5.4 DAC channel1 12-bit left aligned data holding register (DAC\_DHR12L1)

Address offset: 0x0C

Reset value: 0x0000 0000

31	30	29	28	27	26	25	24	23	22	21	20	19	18	17	16
Reserved															
15	14	13	12	11	10	9	8	7	6	5	4	3	2	1	0
DACC1DHR[11:0]												Reserved			
rw	rw	rw	rw	rw	rw	rw	rw	rw	rw	rw	rw				

Bits 31:16 Reserved.

Bit 15:4 **DACC1DHR[11:0]**: DAC channel1 12-bit left-aligned data

These bits are written by software which specify 12-bit data for DAC channel1.

Bits 3:0 Reserved.

### 12.5.5 DAC channel1 8-bit right aligned data holding register (DAC\_DHR8R1)

Address offset: 0x10

Reset value: 0x0000 0000

31	30	29	28	27	26	25	24	23	22	21	20	19	18	17	16
Reserved															
15	14	13	12	11	10	9	8	7	6	5	4	3	2	1	0
Reserved								DACC1DHR[7:0]							
								rw	rw	rw	rw	rw	rw	rw	rw

Bits 31:8 Reserved.

Bits 7:0 **DACC1DHR[7:0]**: DAC channel1 8-bit right-aligned data

These bits are written by software which specify 8-bit data for DAC channel1.



### 12.5.6 DAC channel2 12-bit right aligned data holding register (DAC\_DHR12R2)

Address offset: 0x14

Reset value: 0x0000 0000

31	30	29	28	27	26	25	24	23	22	21	20	19	18	17	16	
Reserved																
15	14	13	12	11	10	9	8	7	6	5	4	3	2	1	0	
Reserved				DACC2DHR[11:0]												
				rw	rw	rw	rw	rw	rw	rw	rw	rw	rw	rw	rw	rw

Bits 31:12 Reserved.

Bits 11:0 **DACC2DHR[11:0]**: DAC channel2 12-bit right-aligned data

These bits are written by software which specify 12-bit data for DAC channel2.

### 12.5.7 DAC channel2 12-bit left aligned data holding register (DAC\_DHR12L2)

Address offset: 0x18

Reset value: 0x0000 0000

31	30	29	28	27	26	25	24	23	22	21	20	19	18	17	16
Reserved															
15	14	13	12	11	10	9	8	7	6	5	4	3	2	1	0
DACC2DHR[11:0]												Reserved			
rw	rw	rw	rw	rw	rw	rw	rw	rw	rw	rw	rw				

Bits 31:16 Reserved.

Bits 15:4 **DACC2DHR[11:0]**: DAC channel2 12-bit left-aligned data

These bits are written by software which specify 12-bit data for DAC channel2.

Bits 3:0 Reserved.

### 12.5.8 DAC channel2 8-bit right-aligned data holding register (DAC\_DHR8R2)

Address offset: 0x1C

Reset value: 0x0000 0000

31	30	29	28	27	26	25	24	23	22	21	20	19	18	17	16
Reserved															
15	14	13	12	11	10	9	8	7	6	5	4	3	2	1	0
Reserved								DACC2DHR[7:0]							
								rw	rw	rw	rw	rw	rw	rw	rw

Bits 31:8 Reserved.

Bits 7:0 **DACC2DHR[7:0]**: DAC channel2 8-bit right-aligned data

These bits are written by software which specify 8-bit data for DAC channel2.

### 12.5.9 Dual DAC 12-bit right-aligned data holding register (DAC\_DHR12RD)

Address offset: 0x20

Reset value: 0x0000 0000

31	30	29	28	27	26	25	24	23	22	21	20	19	18	17	16	
Reserved				DACC2DHR[11:0]												
				rw	rw	rw	rw	rw	rw	rw	rw	rw	rw	rw	rw	rw
15	14	13	12	11	10	9	8	7	6	5	4	3	2	1	0	
Reserved				DACC1DHR[11:0]												
				rw	rw	rw	rw	rw	rw	rw	rw	rw	rw	rw	rw	rw

Bits 31:28 Reserved.

Bits 27:16 **DACC2DHR[11:0]**: DAC channel2 12-bit right-aligned data  
 These bits are written by software which specify 12-bit data for DAC channel2.

Bits 15:12 Reserved.

Bits 11:0 **DACC1DHR[11:0]**: DAC channel1 12-bit right-aligned data  
 These bits are written by software which specify 12-bit data for DAC channel1.

### 12.5.10 DUAL DAC 12-bit left aligned data holding register (DAC\_DHR12LD)

Address offset: 0x24

Reset value: 0x0000 0000

31	30	29	28	27	26	25	24	23	22	21	20	19	18	17	16
DACC2DHR[11:0]												Reserved			
rw	rw	rw	rw	rw	rw	rw	rw	rw	rw	rw	rw				
15	14	13	12	11	10	9	8	7	6	5	4	3	2	1	0
DACC1DHR[11:0]												Reserved			
rw	rw	rw	rw	rw	rw	rw	rw	rw	rw	rw	rw				

Bits 31:20 **DACC2DHR[11:0]**: DAC channel2 12-bit left-aligned data  
 These bits are written by software which specify 12-bit data for DAC channel2.

Bits 19:16 Reserved.

Bits 15:4 **DACC1DHR[11:0]**: DAC channel1 12-bit left-aligned data  
 These bits are written by software which specify 12-bit data for DAC channel1.

Bits 3:0 Reserved.

### 12.5.11 DUAL DAC 8-bit right aligned data holding register (DAC\_DHR8RD)

Address offset: 0x28

Reset value: 0x0000 0000

31	30	29	28	27	26	25	24	23	22	21	20	19	18	17	16
Reserved															
15	14	13	12	11	10	9	8	7	6	5	4	3	2	1	0
DACC2DHR[7:0]								DACC1DHR[7:0]							
rw	rw	rw	rw	rw	rw	rw	rw	rw	rw	rw	rw	rw	rw	rw	rw

Bits 31:16 Reserved.

Bits 15:8 **DACC2DHR[7:0]**: DAC channel2 8-bit right-aligned data  
 These bits are written by software which specify 8-bit data for DAC channel2.

Bits 7:0 **DACC1DHR[7:0]**: DAC channel1 8-bit right-aligned data  
 These bits are written by software which specify 8-bit data for DAC channel1.

### 12.5.12 DAC channel1 data output register (DAC\_DOR1)

Address offset: 0x2C

Reset value: 0x0000 0000

31	30	29	28	27	26	25	24	23	22	21	20	19	18	17	16	
Reserved																
15	14	13	12	11	10	9	8	7	6	5	4	3	2	1	0	
Reserved				DACC1DOR[11:0]												
				r	r	r	r	r	r	r	r	r	r	r	r	r

Bits 31:12 Reserved.

Bit 11:0 **DACC1DOR[11:0]**: DAC channel1 data output  
 These bits are read only, they contain data output for DAC channel1.

### 12.5.13 DAC channel2 data output register (DAC\_DOR2)

Address offset: 0x30

Reset value: 0x0000 0000

31	30	29	28	27	26	25	24	23	22	21	20	19	18	17	16	
Reserved																
15	14	13	12	11	10	9	8	7	6	5	4	3	2	1	0	
Reserved				DACC2DOR[11:0]												
				r	r	r	r	r	r	r	r	r	r	r	r	r

Bits 31:12 Reserved.

Bit 11:0 **DACC2DOR[11:0]**: DAC channel2 data output  
 These bits are read only, they contain data output for DAC channel2.

### 12.5.14 DAC register map

The following table summarizes the DAC registers.

**Table 78. DAC register map**

Offset	Register	31	30	29	28	27	26	25	24	23	22	21	20	19	18	17	16	15	14	13	12	11	10	9	8	7	6	5	4	3	2	1	0				
0x00	DAC_CR	Reserved		DMAEN2	MAMP2[3:0]			WAVE2[2:0]		TSEL2[2:0]			TEN2	BOFF2	EN2	Reserved			DMAEN1	MAMP1[3:0]			WAVE1[2:0]		TSEL1[2:0]		TEN1	BOFF1	EN1								
	Reset value			0	0	0	0	0	0	0	0	0	0	0	0	0	0				0	0	0	0	0	0	0	0	0	0	0	0	0	0			
0x04	DAC_SWTRIGR	Reserved																										SWTRIG2	SWTRIG1								
	Reset value																											0	0								
0x08	DAC_DHR12R1	Reserved																			DACC1DHR[11:0]																
	Reset value																				0	0	0	0	0	0	0	0	0	0	0	0	0	0	0	0	0
0x0C	DAC_DHR12L1	Reserved													DACC1DHR[11:0]							Reserved															
	Reset value														0	0	0	0	0	0	0	0	0	0	0	0	0	0	0	0	0	0	0	0	0	0	0
0x10	DAC_DHR8R1	Reserved																			DACC1DHR[7:0]																
	Reset value																				0	0	0	0	0	0	0	0	0	0	0	0	0	0	0	0	0
0x14	DAC_DHR12R2	Reserved																			DACC2DHR[11:0]																
	Reset value																				0	0	0	0	0	0	0	0	0	0	0	0	0	0	0	0	0
0x18	DAC_DHR12L2	Reserved													DACC2DHR[11:0]							Reserved															
	Reset value														0	0	0	0	0	0	0	0	0	0	0	0	0	0	0	0	0	0	0	0	0	0	0
0x1C	DAC_DHR8R2	Reserved																			DACC2DHR[7:0]																
	Reset value																																				
0x20	DAC_DHR12RD	Reserved		DACC2DHR[11:0]											Reserved		DACC1DHR[11:0]																				
	Reset value			0	0	0	0	0	0	0	0	0	0	0	0	0	0	0	0	0	0	0	0	0	0	0	0	0	0	0	0	0	0				
0x24	DAC_DHR12LD	DACC2DHR[11:0]											Reserved		DACC1DHR[11:0]							Reserved															
	Reset value	0	0	0	0	0	0	0	0	0	0	0	0	0	0	0	0	0	0	0	0	0	0	0	0	0	0	0	0	0	0	0	0				
0x28	DAC_DHR8RD	Reserved																			DACC2DHR[7:0]							DACC1DHR[7:0]									
	Reset value																				0	0	0	0	0	0	0	0	0	0	0	0	0	0	0	0	0
0x2C	DAC_DOR1	Reserved																			DACC1DOR[11:0]																
	Reset value																				0	0	0	0	0	0	0	0	0	0	0	0	0	0	0	0	0
0x30	DAC_DOR2	Reserved																			DACC2DOR[11:0]																
	Reset value																				0	0	0	0	0	0	0	0	0	0	0	0	0	0	0	0	0

Note: Refer to [Table 1 on page 44](#) for the register boundary addresses.

## 13 Advanced-control timers (TIM1&TIM8)

**Low-density devices** are STM32F101xx, STM32F102xx and STM32F103xx microcontrollers where the Flash memory density ranges between 16 and 32 Kbytes.

**Medium-density devices** are STM32F101xx, STM32F102xx and STM32F103xx microcontrollers where the Flash memory density ranges between 64 and 128 Kbytes.

**High-density devices** are STM32F101xx and STM32F103xx microcontrollers where the Flash memory density ranges between 256 and 512 Kbytes.

**XL-density devices** are STM32F101xx and STM32F103xx microcontrollers where the Flash memory density ranges between 768 Kbytes and 1 Mbyte.

**Connectivity line devices** are STM32F105xx and STM32F107xx microcontrollers.

Low- and medium-density STM32F103xx devices, and the STM32F105xx/STM32F107xx connectivity line devices, contain one advanced-control timer (TIM1) whereas high-density and XL-density STM32F103xx devices feature two advanced-control timers (TIM1 and TIM8).

### 13.1 TIM1&TIM8 introduction

The advanced-control timers (TIM1&TIM8) consist of a 16-bit auto-reload counter driven by a programmable prescaler.

It may be used for a variety of purposes, including measuring the pulse lengths of input signals (input capture) or generating output waveforms (output compare, PWM, complementary PWM with dead-time insertion).

Pulse lengths and waveform periods can be modulated from a few microseconds to several milliseconds using the timer prescaler and the RCC clock controller prescalers.

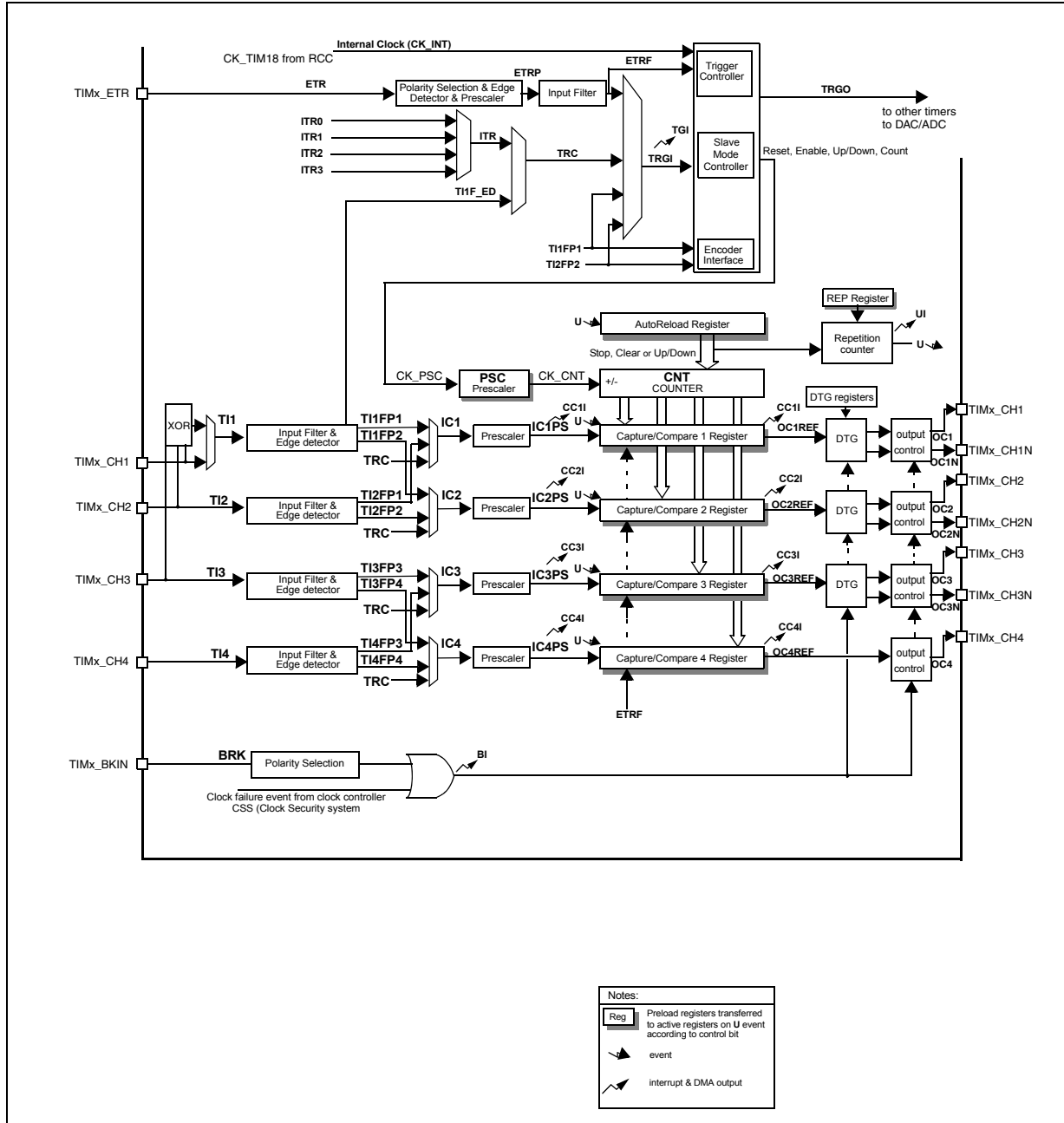
The advanced-control (TIM1&TIM8) and general-purpose (TIMx) timers are completely independent, and do not share any resources. They can be synchronized together as described in [Section 13.3.20](#).

## 13.2 TIM1&TIM8 main features

TIM1&TIM8 timer features include:

- 16-bit up, down, up/down auto-reload counter.
- 16-bit programmable prescaler allowing dividing (also “on the fly”) the counter clock frequency either by any factor between 1 and 65535.
- Up to 4 independent channels for:
  - Input Capture
  - Output Compare
  - PWM generation (Edge and Center-aligned Mode)
  - One-pulse mode output
- Complementary outputs with programmable dead-time
- Synchronization circuit to control the timer with external signals and to interconnect several timers together.
- Repetition counter to update the timer registers only after a given number of cycles of the counter.
- Break input to put the timer’s output signals in reset state or in a known state.
- Interrupt/DMA generation on the following events:
  - Update: counter overflow/underflow, counter initialization (by software or internal/external trigger)
  - Trigger event (counter start, stop, initialization or count by internal/external trigger)
  - Input capture
  - Output compare
  - Break input
- Supports incremental (quadrature) encoder and hall-sensor circuitry for positioning purposes
- Trigger input for external clock or cycle-by-cycle current management

Figure 52. Advanced-control timer block diagram



## 13.3 TIM1&TIM8 functional description

### 13.3.1 Time-base unit

The main block of the programmable advanced-control timer is a 16-bit counter with its related auto-reload register. The counter can count up, down or both up and down. The counter clock can be divided by a prescaler.

The counter, the auto-reload register and the prescaler register can be written or read by software. This is true even when the counter is running.

The time-base unit includes:

- Counter register (TIMx\_CNT)
- Prescaler register (TIMx\_PSC)
- Auto-reload register (TIMx\_ARR)
- Repetition counter register (TIMx\_RCR)

The auto-reload register is preloaded. Writing to or reading from the auto-reload register accesses the preload register. The content of the preload register are transferred into the shadow register permanently or at each update event (UEV), depending on the auto-reload preload enable bit (ARPE) in TIMx\_CR1 register. The update event is sent when the counter reaches the overflow (or underflow when downcounting) and if the UDIS bit equals 0 in the TIMx\_CR1 register. It can also be generated by software. The generation of the update event is described in detailed for each configuration.

The counter is clocked by the prescaler output CK\_CNT, which is enabled only when the counter enable bit (CEN) in TIMx\_CR1 register is set (refer also to the slave mode controller description to get more details on counter enabling).

Note that the counter starts counting 1 clock cycle after setting the CEN bit in the TIMx\_CR1 register.

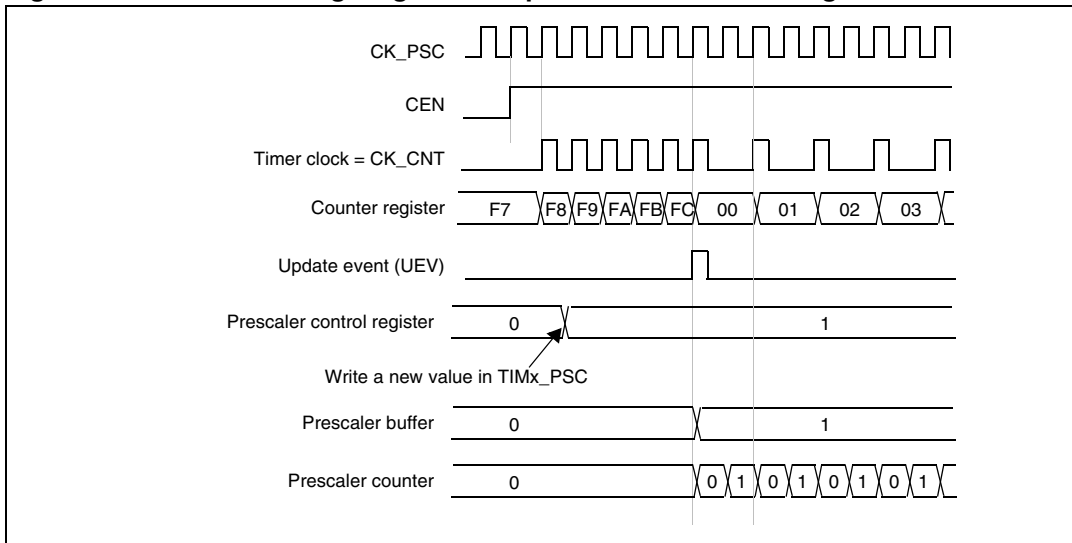
#### Prescaler description

The prescaler can divide the counter clock frequency by any factor between 1 and 65536. It is based on a 16-bit counter controlled through a 16-bit register (in the TIMx\_PSC register). It can be changed on the fly as this control register is buffered. The new prescaler ratio is taken into account at the next update event.

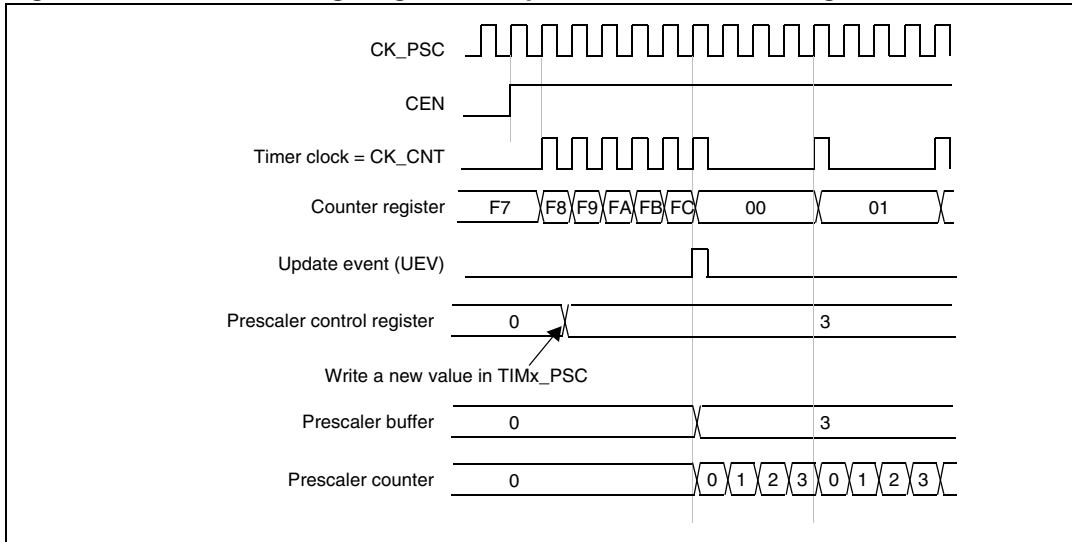
*Figure 54* and *Figure 55* give some examples of the counter behavior when the prescaler ratio is changed on the fly:



**Figure 53. Counter timing diagram with prescaler division change from 1 to 2**



**Figure 54. Counter timing diagram with prescaler division change from 1 to 4**



### 13.3.2 Counter modes

#### Upcounting mode

In upcounting mode, the counter counts from 0 to the auto-reload value (content of the TIMx\_ARR register), then restarts from 0 and generates a counter overflow event.

If the repetition counter is used, the update event (UEV) is generated after upcounting is repeated for the number of times programmed in the repetition counter register (TIMx\_RCR). Else the update event is generated at each counter overflow.

Setting the UG bit in the TIMx\_EGR register (by software or by using the slave mode controller) also generates an update event.

The UEV event can be disabled by software by setting the UDIS bit in the TIMx\_CR1 register. This is to avoid updating the shadow registers while writing new values in the

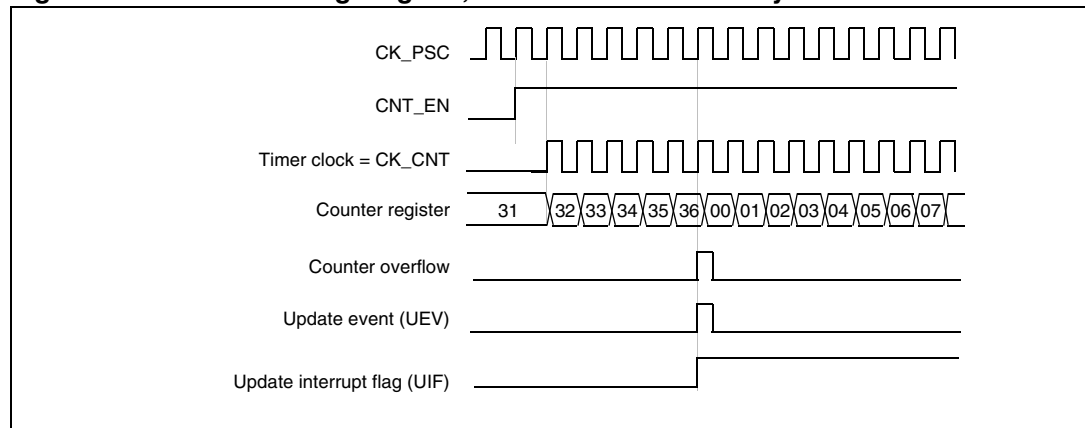
preload registers. Then no update event occurs until the UDIS bit has been written to 0. However, the counter restarts from 0, as well as the counter of the prescaler (but the prescale rate does not change). In addition, if the URS bit (update request selection) in TIMx\_CR1 register is set, setting the UG bit generates an update event UEV but without setting the UIF flag (thus no interrupt or DMA request is sent). This is to avoid generating both update and capture interrupts when clearing the counter on the capture event.

When an update event occurs, all the registers are updated and the update flag (UIF bit in TIMx\_SR register) is set (depending on the URS bit):

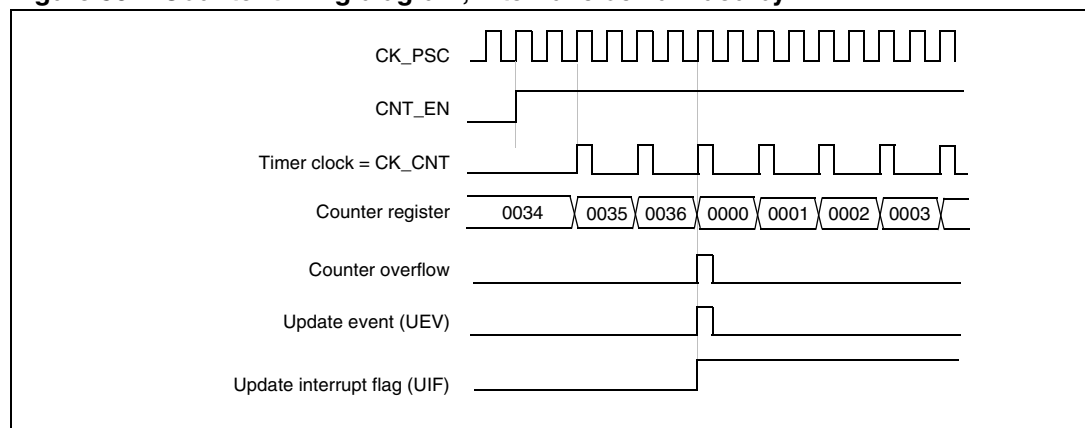
- The repetition counter is reloaded with the content of TIMx\_RCR register,
- The auto-reload shadow register is updated with the preload value (TIMx\_ARR),
- The buffer of the prescaler is reloaded with the preload value (content of the TIMx\_PSC register).

The following figures show some examples of the counter behavior for different clock frequencies when TIMx\_ARR=0x36.

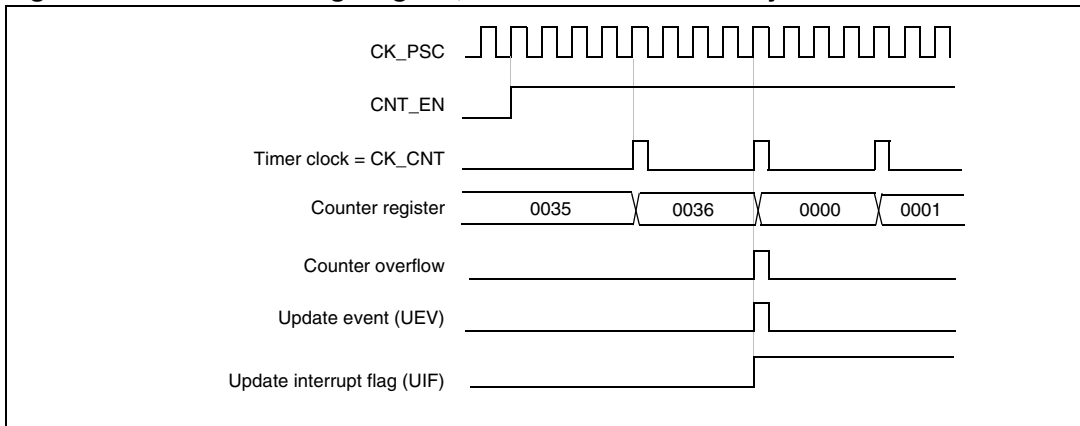
**Figure 55. Counter timing diagram, internal clock divided by 1**



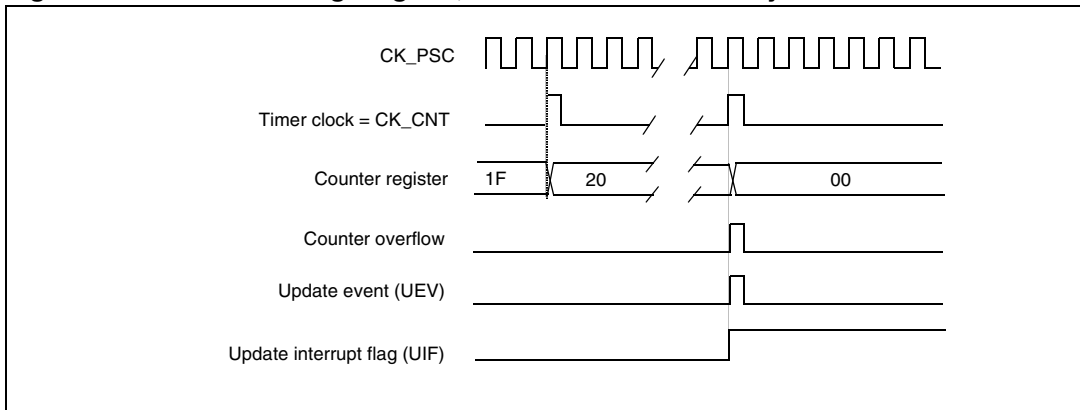
**Figure 56. Counter timing diagram, internal clock divided by 2**



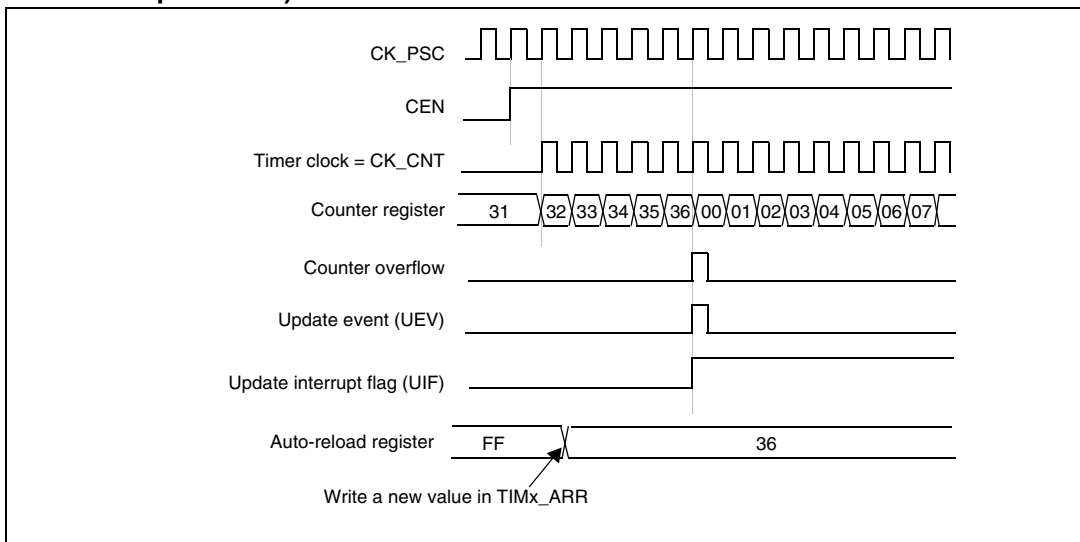
**Figure 57. Counter timing diagram, internal clock divided by 4**



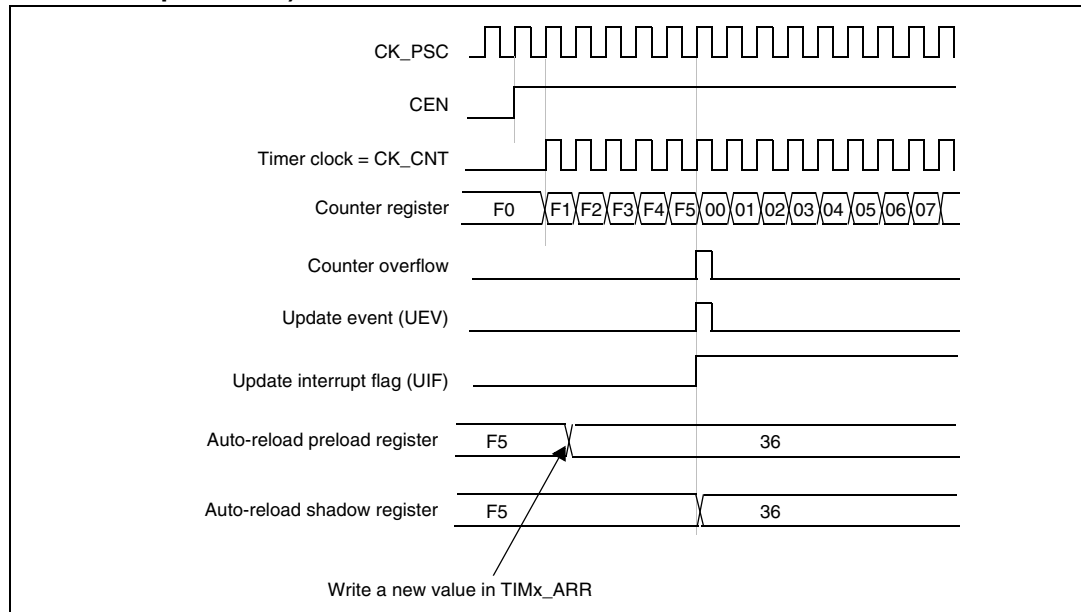
**Figure 58. Counter timing diagram, internal clock divided by N**



**Figure 59. Counter timing diagram, update event when ARPE=0 (TIMx\_ARR not preloaded)**



**Figure 60. Counter timing diagram, update event when ARPE=1 (TIMx\_ARR preloaded)**



### Downcounting mode

In downcounting mode, the counter counts from the auto-reload value (content of the TIMx\_ARR register) down to 0, then restarts from the auto-reload value and generates a counter underflow event.

If the repetition counter is used, the update event (UEV) is generated after downcounting is repeated for the number of times programmed in the repetition counter register (TIMx\_RCR). Else the update event is generated at each counter underflow.

Setting the UG bit in the TIMx\_EGR register (by software or by using the slave mode controller) also generates an update event.

The UEV update event can be disabled by software by setting the UDIS bit in TIMx\_CR1 register. This is to avoid updating the shadow registers while writing new values in the preload registers. Then no update event occurs until UDIS bit has been written to 0. However, the counter restarts from the current auto-reload value, whereas the counter of the prescaler restarts from 0 (but the prescale rate doesn't change).

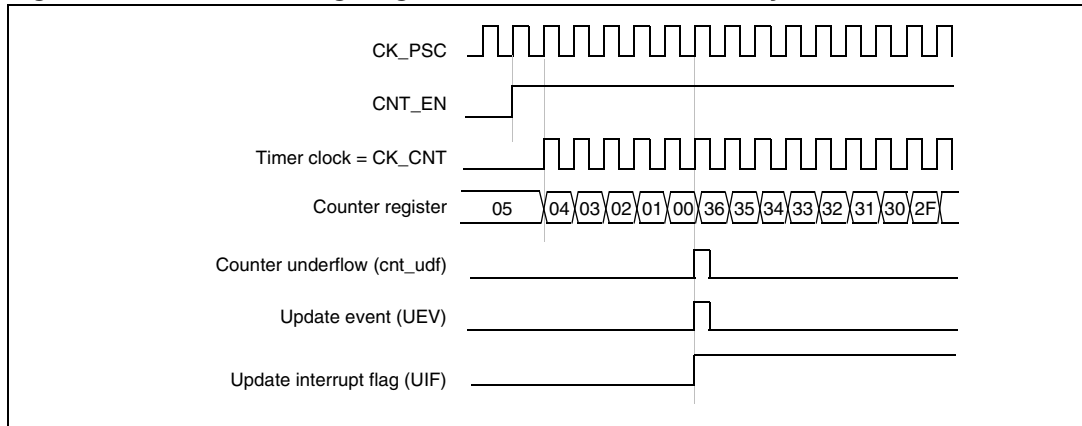
In addition, if the URS bit (update request selection) in TIMx\_CR1 register is set, setting the UG bit generates an update event UEV but without setting the UIF flag (thus no interrupt or DMA request is sent). This is to avoid generating both update and capture interrupts when clearing the counter on the capture event.

When an update event occurs, all the registers are updated and the update flag (UIF bit in TIMx\_SR register) is set (depending on the URS bit):

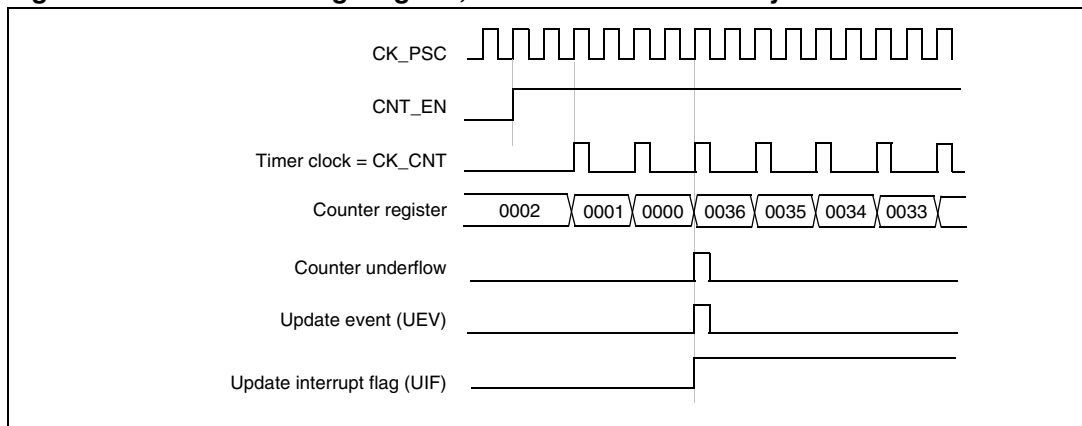
- The repetition counter is reloaded with the content of TIMx\_RCR register
- The buffer of the prescaler is reloaded with the preload value (content of the TIMx\_PSC register)
- The auto-reload active register is updated with the preload value (content of the TIMx\_ARR register). Note that the auto-reload is updated before the counter is reloaded, so that the next period is the expected one

The following figures show some examples of the counter behavior for different clock frequencies when TIMx\_ARR=0x36.

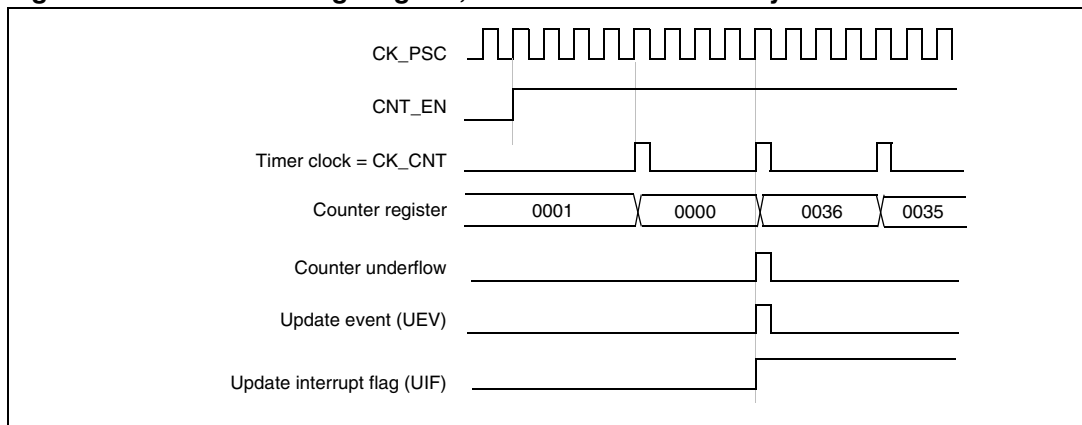
**Figure 61. Counter timing diagram, internal clock divided by 1**



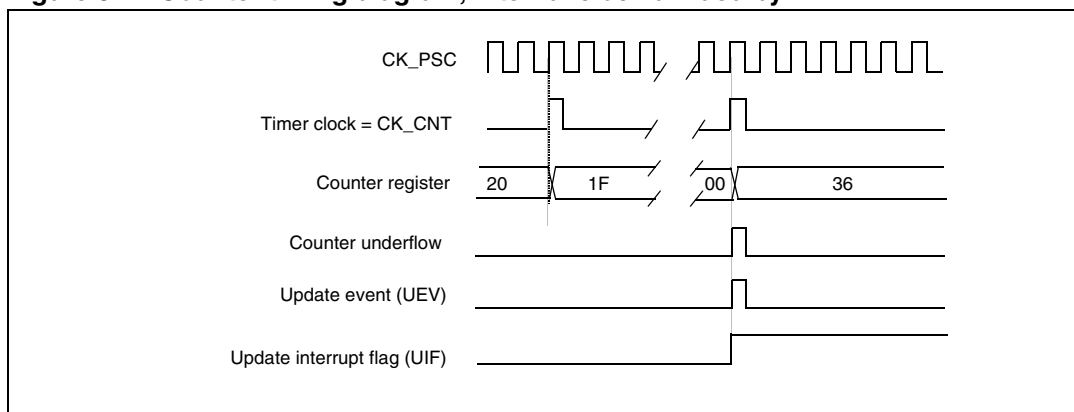
**Figure 62. Counter timing diagram, internal clock divided by 2**



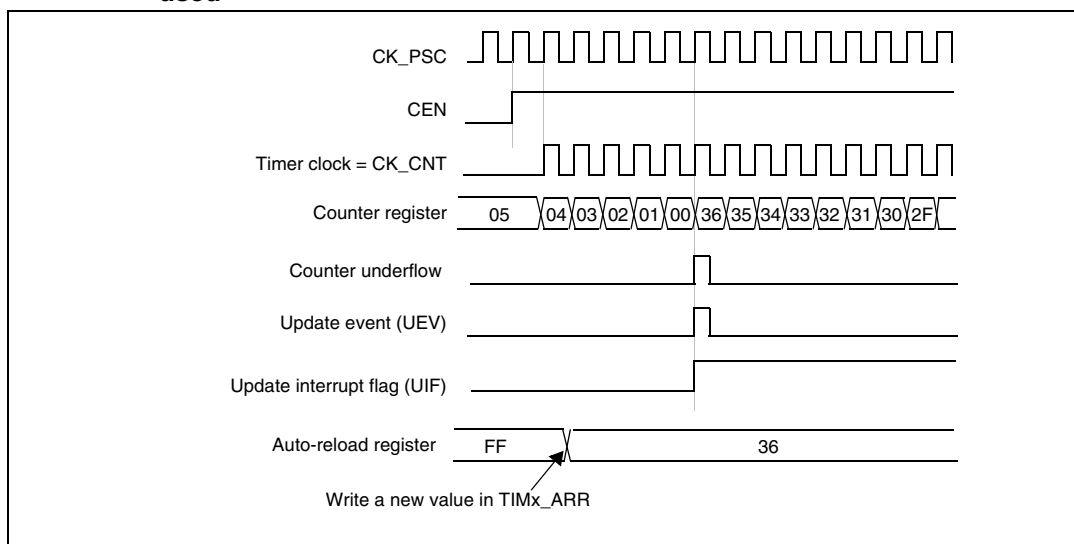
**Figure 63. Counter timing diagram, internal clock divided by 4**



**Figure 64. Counter timing diagram, internal clock divided by N**



**Figure 65. Counter timing diagram, update event when repetition counter is not used**



**Center-aligned mode (up/down counting)**

In center-aligned mode, the counter counts from 0 to the auto-reload value (content of the TIMx\_ARR register) – 1, generates a counter overflow event, then counts from the auto-reload value down to 1 and generates a counter underflow event. Then it restarts counting from 0.

Center-aligned mode is active when the CMS bits in TIMx\_CR1 register are not equal to '00'. The Output compare interrupt flag of channels configured in output is set when: the counter counts down (Center aligned mode 1, CMS = "01"), the counter counts up (Center aligned mode 2, CMS = "10") the counter counts up and down (Center aligned mode 3, CMS = "11").

In this mode, the DIR direction bit in the TIMx\_CR1 register cannot be written. It is updated by hardware and gives the current direction of the counter.

The update event can be generated at each counter overflow and at each counter underflow or by setting the UG bit in the TIMx\_EGR register (by software or by using the slave mode controller) also generates an update event. In this case, the counter restarts counting from 0, as well as the counter of the prescaler.

The UEV update event can be disabled by software by setting the UDIS bit in the TIMx\_CR1 register. This is to avoid updating the shadow registers while writing new values in the preload registers. Then no update event occurs until UDIS bit has been written to 0. However, the counter continues counting up and down, based on the current auto-reload value.

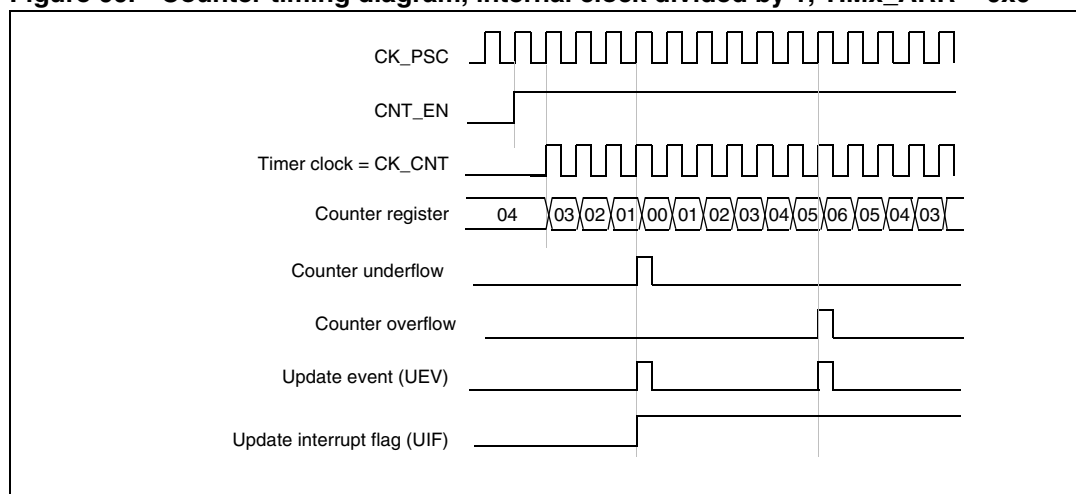
In addition, if the URS bit (update request selection) in TIMx\_CR1 register is set, setting the UG bit generates an UEV update event but without setting the UIF flag (thus no interrupt or DMA request is sent). This is to avoid generating both update and capture interrupts when clearing the counter on the capture event.

When an update event occurs, all the registers are updated and the update flag (UIF bit in TIMx\_SR register) is set (depending on the URS bit):

- The repetition counter is reloaded with the content of TIMx\_RCR register
- The buffer of the prescaler is reloaded with the preload value (content of the TIMx\_PSC register)
- The auto-reload active register is updated with the preload value (content of the TIMx\_ARR register). Note that if the update source is a counter overflow, the auto-reload is updated before the counter is reloaded, so that the next period is the expected one (the counter is loaded with the new value).

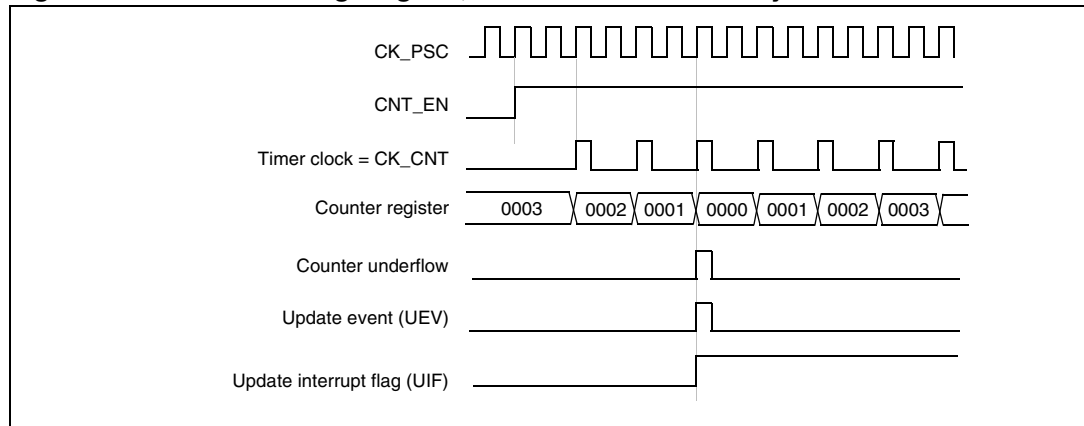
The following figures show some examples of the counter behavior for different clock frequencies.

**Figure 66. Counter timing diagram, internal clock divided by 1, TIMx\_ARR = 0x6**

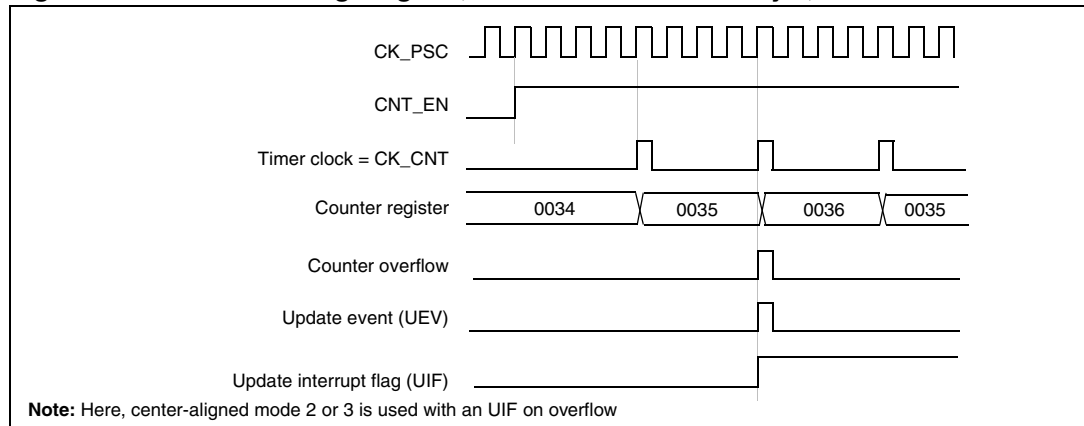


1. Here, center-aligned mode 1 is used (for more details refer to [Section 13.4: TIM1&TIM8 registers on page 310](#)).

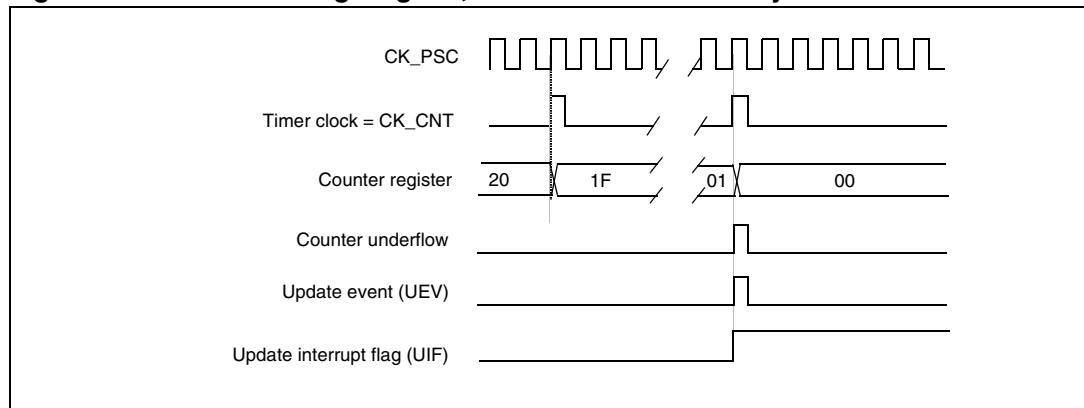
**Figure 67. Counter timing diagram, internal clock divided by 2**



**Figure 68. Counter timing diagram, internal clock divided by 4, TIMx\_ARR=0x36**

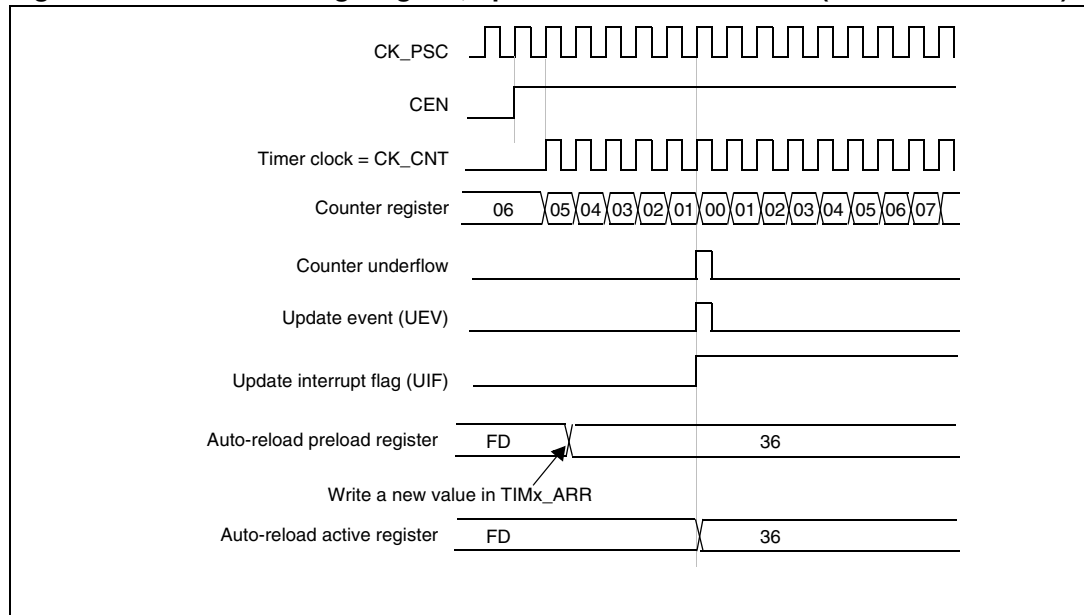


**Figure 69. Counter timing diagram, internal clock divided by N**

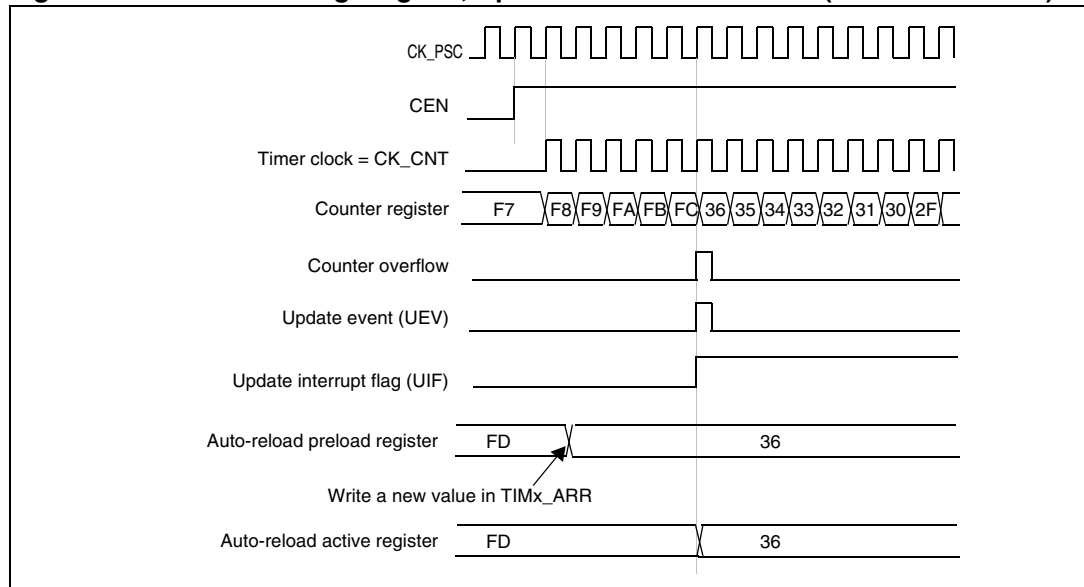




**Figure 70. Counter timing diagram, update event with ARPE=1 (counter underflow)**



**Figure 71. Counter timing diagram, Update event with ARPE=1 (counter overflow)**



### 13.3.3 Repetition counter

*Section 13.3.1: Time-base unit* describes how the update event (UEV) is generated with respect to the counter overflows/underflows. It is actually generated only when the repetition counter has reached zero. This can be useful when generating PWM signals.

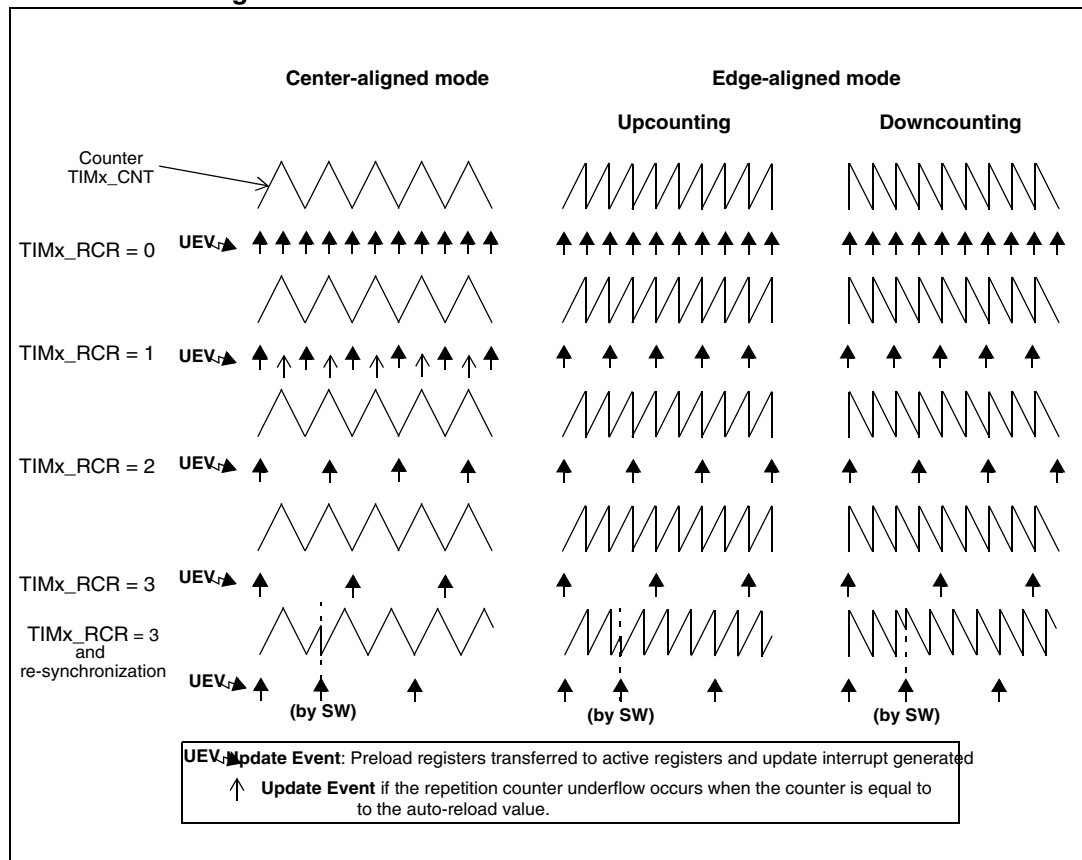
This means that data are transferred from the preload registers to the shadow registers (TIMx\_ARR auto-reload register, TIMx\_PSC prescaler register, but also TIMx\_CCRx capture/compare registers in compare mode) every N counter overflows or underflows, where N is the value in the TIMx\_RCR repetition counter register.

The repetition counter is decremented:

- At each counter overflow in upcounting mode,
- At each counter underflow in downcounting mode,
- At each counter overflow and at each counter underflow in center-aligned mode.  
 Although this limits the maximum number of repetition to 128 PWM cycles, it makes it possible to update the duty cycle twice per PWM period. When refreshing compare registers only once per PWM period in center-aligned mode, maximum resolution is  $2xT_{ck}$ , due to the symmetry of the pattern.

The repetition counter is an auto-reload type; the repetition rate is maintained as defined by the TIMx\_RCR register value (refer to [Figure 72](#)). When the update event is generated by software (by setting the UG bit in TIMx\_EGR register) or by hardware through the slave mode controller, it occurs immediately whatever the value of the repetition counter is and the repetition counter is reloaded with the content of the TIMx\_RCR register.

**Figure 72. Update rate examples depending on mode and TIMx\_RCR register settings**



### 13.3.4 Clock selection

The counter clock can be provided by the following clock sources:

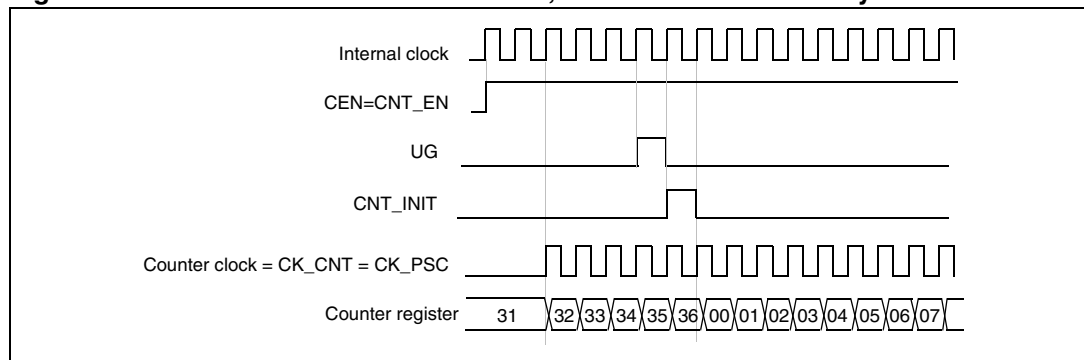
- Internal clock (CK\_INT)
- External clock mode1: external input pin
- External clock mode2: external trigger input ETR
- Internal trigger inputs (ITRx): using one timer as prescaler for another timer, for example, you can configure Timer 1 to act as a prescaler for Timer 2. Refer to [Using one timer as prescaler for another](#) for more details.

#### Internal clock source (CK\_INT)

If the slave mode controller is disabled (SMS=000), then the CEN, DIR (in the TIMx\_CR1 register) and UG bits (in the TIMx\_EGR register) are actual control bits and can be changed only by software (except UG which remains cleared automatically). As soon as the CEN bit is written to 1, the prescaler is clocked by the internal clock CK\_INT.

Figure 73 shows the behavior of the control circuit and the upcounter in normal mode, without prescaler.

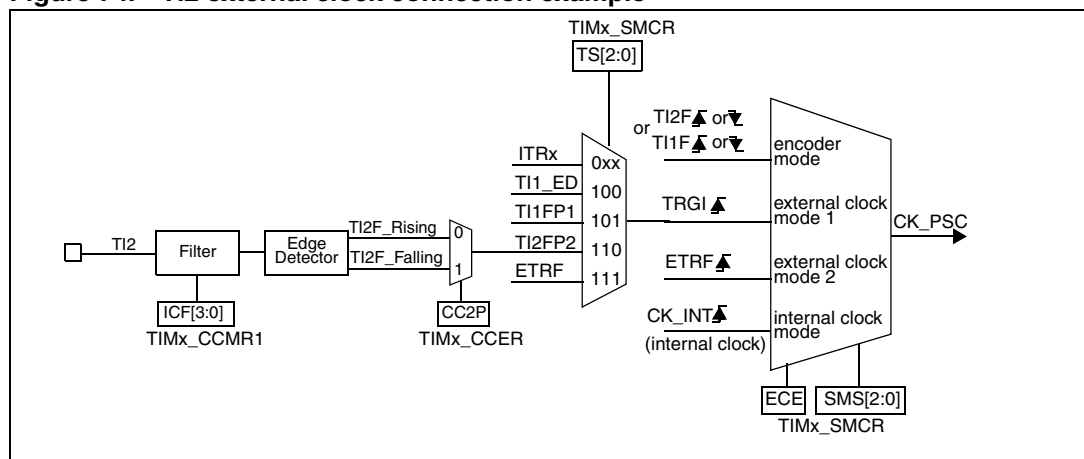
Figure 73. Control circuit in normal mode, internal clock divided by 1



#### External clock source mode 1

This mode is selected when SMS=111 in the TIMx\_SMCR register. The counter can count at each rising or falling edge on a selected input.

Figure 74. TI2 external clock connection example



For example, to configure the upcounter to count in response to a rising edge on the TI2 input, use the following procedure:

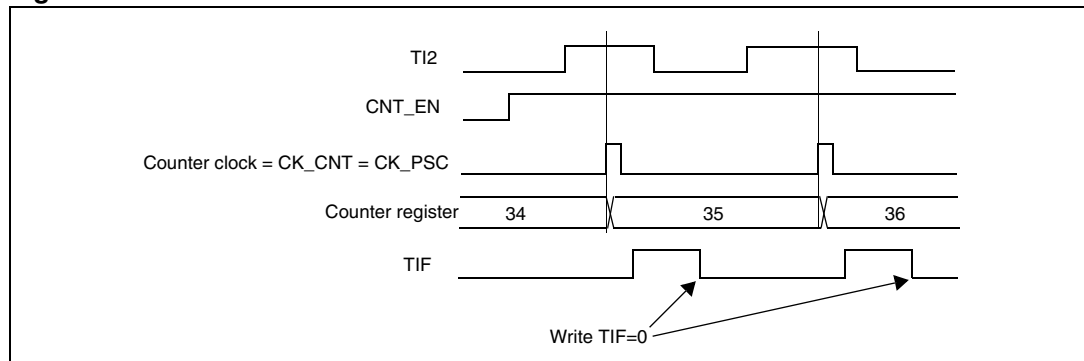
1. Configure channel 2 to detect rising edges on the TI2 input by writing CC2S = '01' in the TIMx\_CCMR1 register.
2. Configure the input filter duration by writing the IC2F[3:0] bits in the TIMx\_CCMR1 register (if no filter is needed, keep IC2F=0000).
3. Select rising edge polarity by writing CC2P=0 in the TIMx\_CCER register.
4. Configure the timer in external clock mode 1 by writing SMS=111 in the TIMx\_SMCR register.
5. Select TI2 as the trigger input source by writing TS=110 in the TIMx\_SMCR register.
6. Enable the counter by writing CEN=1 in the TIMx\_CR1 register.

*Note:* The capture prescaler is not used for triggering, so you don't need to configure it.

When a rising edge occurs on TI2, the counter counts once and the TIF flag is set.

The delay between the rising edge on TI2 and the actual clock of the counter is due to the resynchronization circuit on TI2 input.

**Figure 75. Control circuit in external clock mode 1**



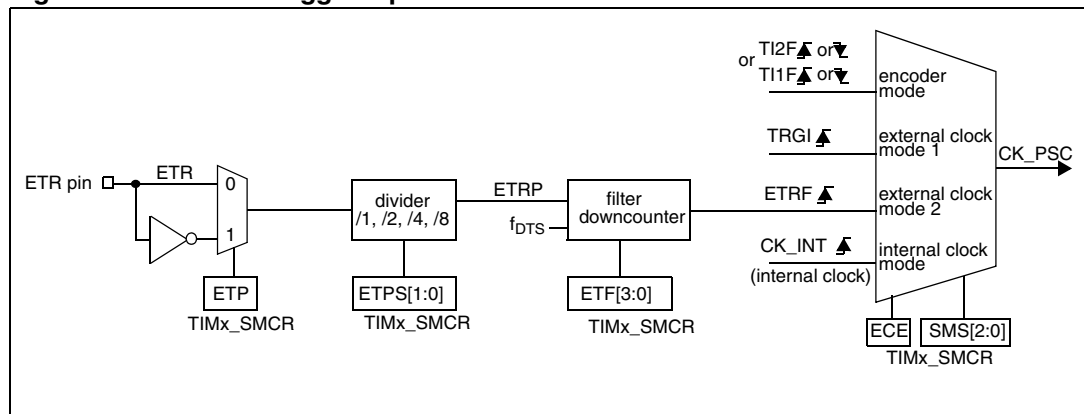
**External clock source mode 2**

This mode is selected by writing ECE=1 in the TIMx\_SMCR register.

The counter can count at each rising or falling edge on the external trigger input ETR.

The [Figure 76](#) gives an overview of the external trigger input block.

**Figure 76. External trigger input block**



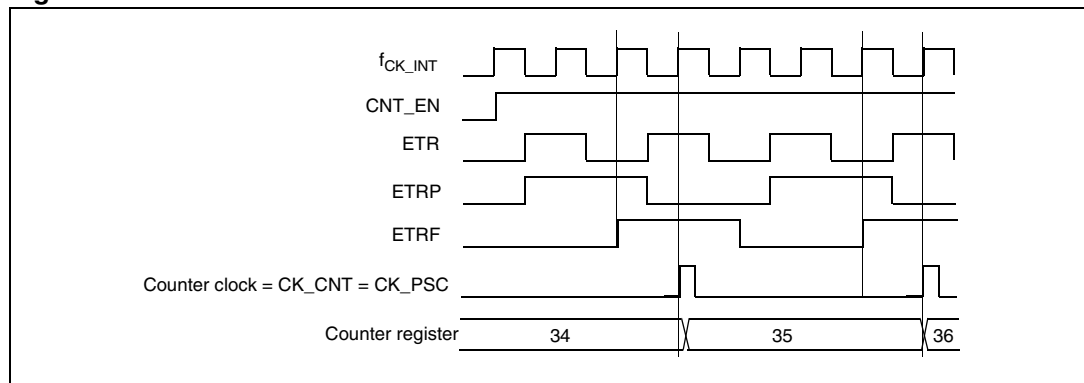
For example, to configure the upcounter to count each 2 rising edges on ETR, use the following procedure:

1. As no filter is needed in this example, write ETF[3:0]=0000 in the TIMx\_SMCR register.
2. Set the prescaler by writing ETPS[1:0]=01 in the TIMx\_SMCR register
3. Select rising edge detection on the ETR pin by writing ETP=0 in the TIMx\_SMCR register
4. Enable external clock mode 2 by writing ECE=1 in the TIMx\_SMCR register.
5. Enable the counter by writing CEN=1 in the TIMx\_CR1 register.

The counter counts once each 2 ETR rising edges.

The delay between the rising edge on ETR and the actual clock of the counter is due to the resynchronization circuit on the ETRP signal.

**Figure 77. Control circuit in external clock mode 2**



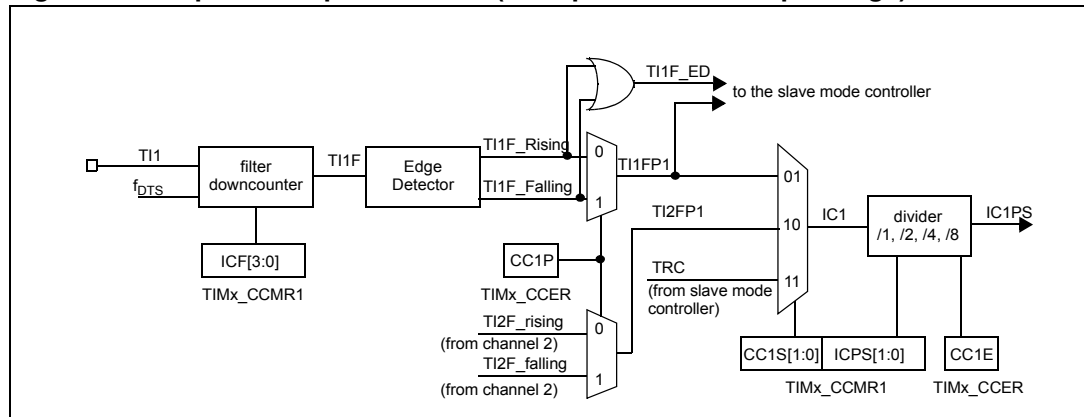
### 13.3.5 Capture/compare channels

Each Capture/Compare channel is built around a capture/compare register (including a shadow register), a input stage for capture (with digital filter, multiplexing and prescaler) and an output stage (with comparator and output control).

[Figure 78](#) to [Figure 81](#) give an overview of one Capture/Compare channel.

The input stage samples the corresponding TIx input to generate a filtered signal TIxF. Then, an edge detector with polarity selection generates a signal (TIxFPx) which can be used as trigger input by the slave mode controller or as the capture command. It is prescaled before the capture register (ICxPS).

Figure 78. Capture/compare channel (example: channel 1 input stage)



The output stage generates an intermediate waveform which is then used for reference: OCxRef (active high). The polarity acts at the end of the chain.

Figure 79. Capture/compare channel 1 main circuit

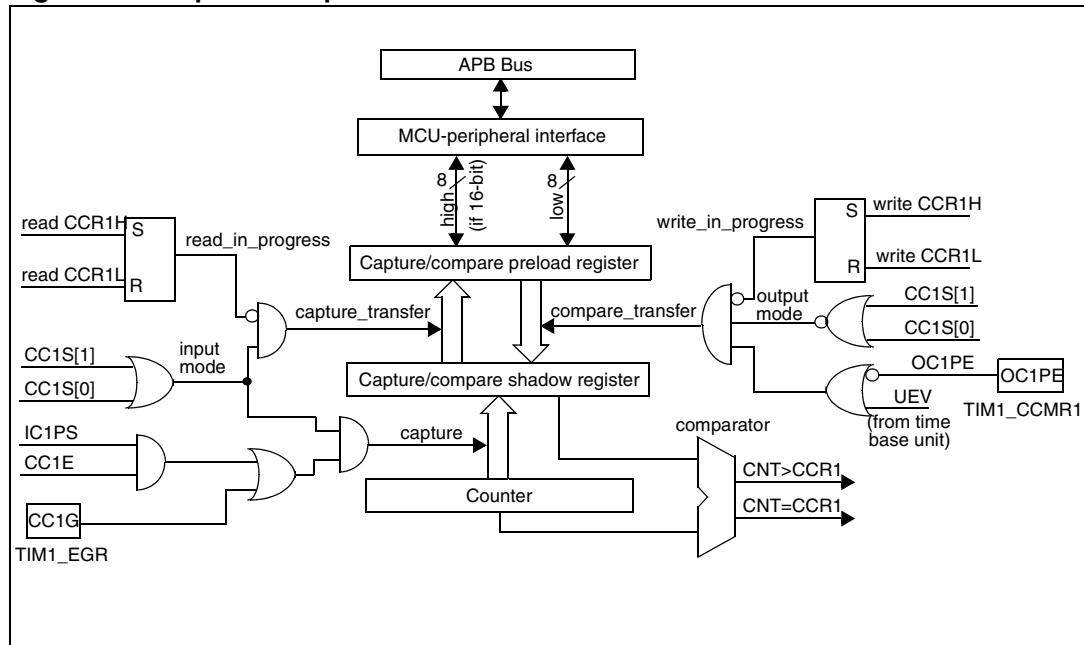


Figure 80. Output stage of capture/compare channel (channel 1 to 3)

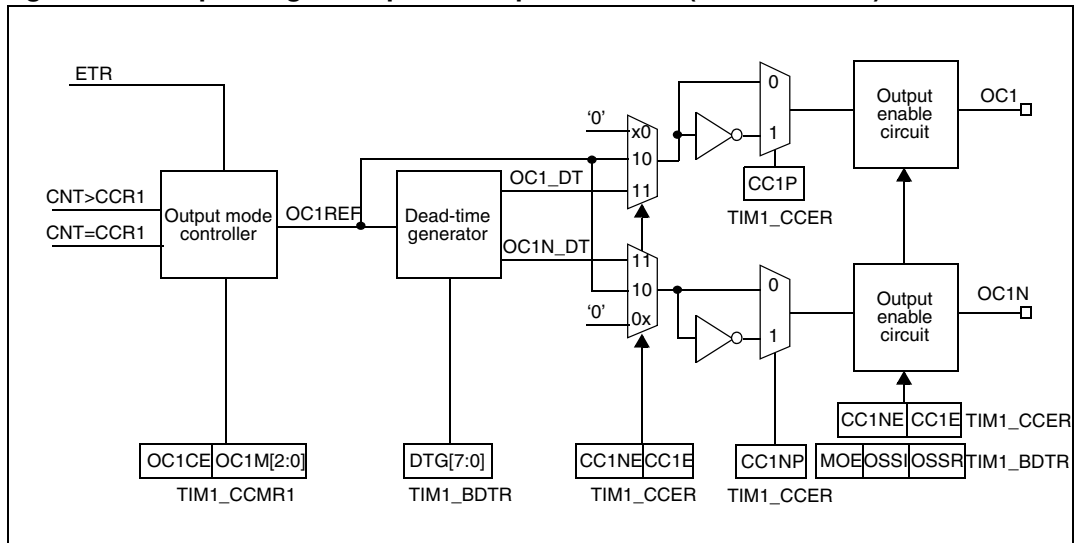
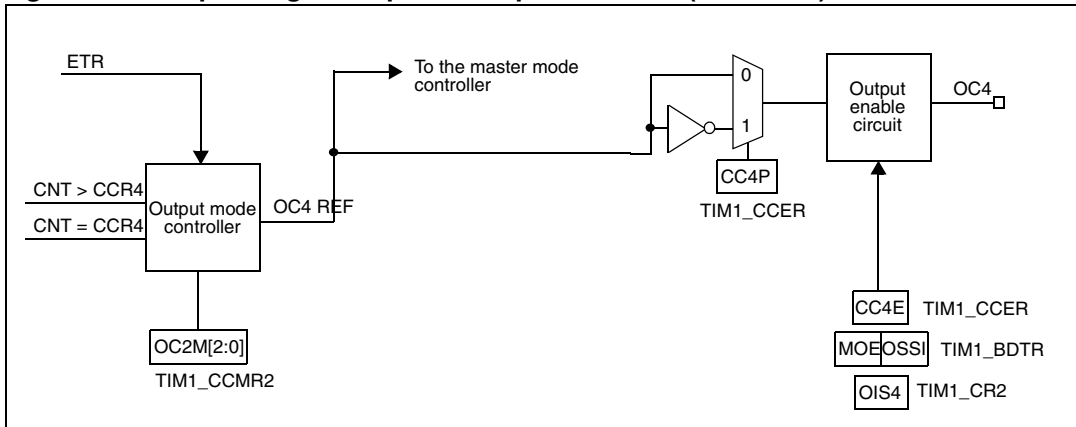


Figure 81. Output stage of capture/compare channel (channel 4)



The capture/compare block is made of one preload register and one shadow register. Write and read always access the preload register.

In capture mode, captures are actually done in the shadow register, which is copied into the preload register.

In compare mode, the content of the preload register is copied into the shadow register which is compared to the counter.

### 13.3.6 Input capture mode

In Input capture mode, the Capture/Compare Registers (TIMx\_CCRx) are used to latch the value of the counter after a transition detected by the corresponding ICx signal. When a capture occurs, the corresponding CCxIF flag (TIMx\_SR register) is set and an interrupt or a DMA request can be sent if they are enabled. If a capture occurs while the CCxIF flag was already high, then the over-capture flag CCxOF (TIMx\_SR register) is set. CCxIF can be cleared by software by writing it to '0' or by reading the captured data stored in the TIMx\_CCRx register. CCxOF is cleared when you write it to '0'.

The following example shows how to capture the counter value in TIMx\_CCR1 when TI1 input rises. To do this, use the following procedure:

- Select the active input: TIMx\_CCR1 must be linked to the TI1 input, so write the CC1S bits to 01 in the TIMx\_CCMR1 register. As soon as CC1S becomes different from 00, the channel is configured in input and the TIMx\_CCR1 register becomes read-only.
- Program the input filter duration you need with respect to the signal you connect to the timer (when the input is one of the TIx (ICxF bits in the TIMx\_CCMRx register). Let's imagine that, when toggling, the input signal is not stable during at most 5 internal clock cycles. We must program a filter duration longer than these 5 clock cycles. We can validate a transition on TI1 when 8 consecutive samples with the new level have been detected (sampled at  $f_{DTS}$  frequency). Then write IC1F bits to 0011 in the TIMx\_CCMR1 register.
- Select the edge of the active transition on the TI1 channel by writing CC1P bit to 0 in the TIMx\_CCER register (rising edge in this case).
- Program the input prescaler. In our example, we wish the capture to be performed at each valid transition, so the prescaler is disabled (write IC1PS bits to '00' in the TIMx\_CCMR1 register).
- Enable capture from the counter into the capture register by setting the CC1E bit in the TIMx\_CCER register.
- If needed, enable the related interrupt request by setting the CC1IE bit in the TIMx\_DIER register, and/or the DMA request by setting the CC1DE bit in the TIMx\_DIER register.

When an input capture occurs:

- The TIMx\_CCR1 register gets the value of the counter on the active transition.
- CC1IF flag is set (interrupt flag). CC1OF is also set if at least two consecutive captures occurred whereas the flag was not cleared.
- An interrupt is generated depending on the CC1IE bit.
- A DMA request is generated depending on the CC1DE bit.

In order to handle the overcapture, it is recommended to read the data before the overcapture flag. This is to avoid missing an overcapture which could happen after reading the flag and before reading the data.

*Note:* IC interrupt and/or DMA requests can be generated by software by setting the corresponding CCxG bit in the TIMx\_EGR register.

### 13.3.7 PWM input mode

This mode is a particular case of input capture mode. The procedure is the same except:

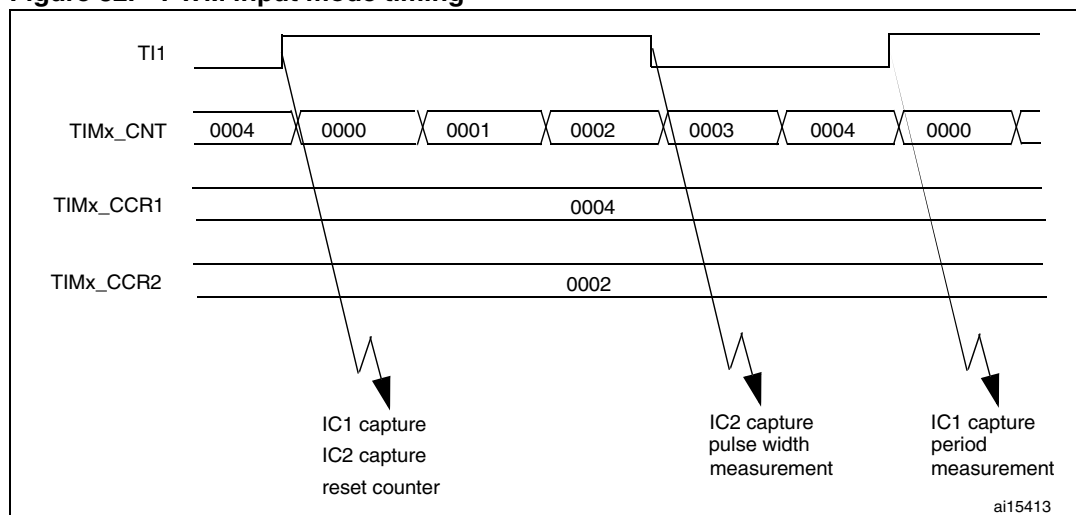
- Two ICx signals are mapped on the same TIx input.
- These 2 ICx signals are active on edges with opposite polarity.
- One of the two TIxFP signals is selected as trigger input and the slave mode controller is configured in reset mode.



For example, you can measure the period (in TIMx\_CCR1 register) and the duty cycle (in TIMx\_CCR2 register) of the PWM applied on TI1 using the following procedure (depending on CK\_INT frequency and prescaler value):

- Select the active input for TIMx\_CCR1: write the CC1S bits to 01 in the TIMx\_CCMR1 register (TI1 selected).
- Select the active polarity for TI1FP1 (used both for capture in TIMx\_CCR1 and counter clear): write the CC1P bit to '0' (active on rising edge).
- Select the active input for TIMx\_CCR2: write the CC2S bits to 10 in the TIMx\_CCMR1 register (TI1 selected).
- Select the active polarity for TI1FP2 (used for capture in TIMx\_CCR2): write the CC2P bit to '1' (active on falling edge).
- Select the valid trigger input: write the TS bits to 101 in the TIMx\_SMCR register (TI1FP1 selected).
- Configure the slave mode controller in reset mode: write the SMS bits to 100 in the TIMx\_SMCR register.
- Enable the captures: write the CC1E and CC2E bits to '1' in the TIMx\_CCER register.

**Figure 82. PWM input mode timing**



1. The PWM input mode can be used only with the TIMx\_CH1/TIMx\_CH2 signals due to the fact that only TI1FP1 and TI2FP2 are connected to the slave mode controller.

### 13.3.8 Forced output mode

In output mode (CCxS bits = 00 in the TIMx\_CCMRx register), each output compare signal (OCxREF and then OCx/OCxN) can be forced to active or inactive level directly by software, independently of any comparison between the output compare register and the counter.

To force an output compare signal (OCxREF/OCx) to its active level, you just need to write 101 in the OCxM bits in the corresponding TIMx\_CCMRx register. Thus OCxREF is forced high (OCxREF is always active high) and OCx get opposite value to CCxP polarity bit.

For example: CCxP=0 (OCx active high) => OCx is forced to high level.

The OCxREF signal can be forced low by writing the OCxM bits to 100 in the TIMx\_CCMRx register.

Anyway, the comparison between the TIMx\_CCRx shadow register and the counter is still performed and allows the flag to be set. Interrupt and DMA requests can be sent accordingly. This is described in the output compare mode section below.

### 13.3.9 Output compare mode

This function is used to control an output waveform or indicating when a period of time has elapsed.

When a match is found between the capture/compare register and the counter, the output compare function:

- Assigns the corresponding output pin to a programmable value defined by the output compare mode (OCxM bits in the TIMx\_CCMRx register) and the output polarity (CCxP bit in the TIMx\_CCER register). The output pin can keep its level (OCXM=000), be set active (OCXM=001), be set inactive (OCXM=010) or can toggle (OCXM=011) on match.
- Sets a flag in the interrupt status register (CCxIF bit in the TIMx\_SR register).
- Generates an interrupt if the corresponding interrupt mask is set (CCXIE bit in the TIMx\_DIER register).
- Sends a DMA request if the corresponding enable bit is set (CCxDE bit in the TIMx\_DIER register, CCDS bit in the TIMx\_CR2 register for the DMA request selection).

The TIMx\_CCRx registers can be programmed with or without preload registers using the OCxPE bit in the TIMx\_CCMRx register.

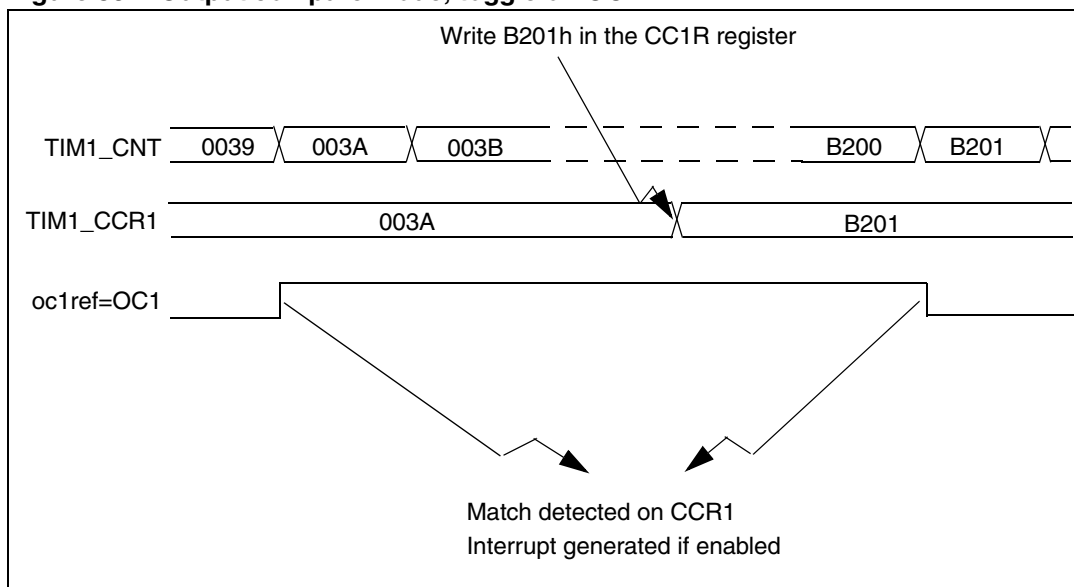
In output compare mode, the update event UEV has no effect on OCxREF and OCx output. The timing resolution is one count of the counter. Output compare mode can also be used to output a single pulse (in One Pulse mode).

Procedure:

1. Select the counter clock (internal, external, prescaler).
2. Write the desired data in the TIMx\_ARR and TIMx\_CCRx registers.
3. Set the CCxIE bit if an interrupt request is to be generated.
4. Select the output mode. For example:
  - Write OCxM = 011 to toggle OCx output pin when CNT matches CCRx
  - Write OCxPE = 0 to disable preload register
  - Write CCxP = 0 to select active high polarity
  - Write CCxE = 1 to enable the output
5. Enable the counter by setting the CEN bit in the TIMx\_CR1 register.

The TIMx\_CCRx register can be updated at any time by software to control the output waveform, provided that the preload register is not enabled (OCxPE='0', else TIMx\_CCRx shadow register is updated only at the next update event UEV). An example is given in [Figure 83](#).

**Figure 83. Output compare mode, toggle on OC1.**



### 13.3.10 PWM mode

Pulse Width Modulation mode allows you to generate a signal with a frequency determined by the value of the TIMx\_ARR register and a duty cycle determined by the value of the TIMx\_CCRx register.

The PWM mode can be selected independently on each channel (one PWM per OCx output) by writing '110' (PWM mode 1) or '111' (PWM mode 2) in the OCxM bits in the TIMx\_CCMRx register. You must enable the corresponding preload register by setting the OCxPE bit in the TIMx\_CCMRx register, and eventually the auto-reload preload register (in upcounting or center-aligned modes) by setting the ARPE bit in the TIMx\_CR1 register.

As the preload registers are transferred to the shadow registers only when an update event occurs, before starting the counter, you have to initialize all the registers by setting the UG bit in the TIMx\_EGR register.

OCx polarity is software programmable using the CCxP bit in the TIMx\_CCER register. It can be programmed as active high or active low. OCx output is enabled by a combination of the CCxE, CCxNE, MOE, OSSI and OSSR bits (TIMx\_CCER and TIMx\_BDTR registers). Refer to the TIMx\_CCER register description for more details.

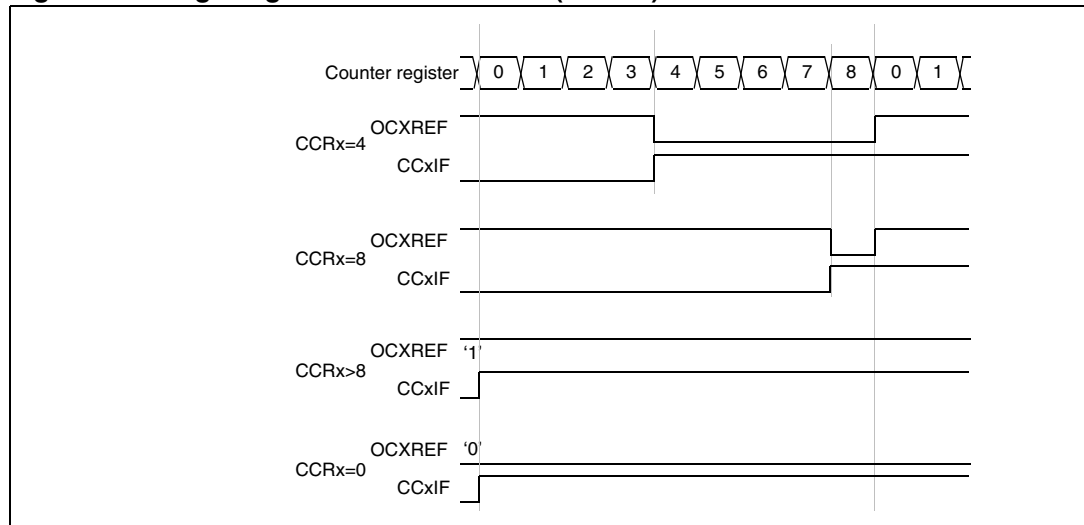
In PWM mode (1 or 2), TIMx\_CNT and TIMx\_CCRx are always compared to determine whether  $TIMx\_CCRx \leq TIMx\_CNT$  or  $TIMx\_CNT \leq TIMx\_CCRx$  (depending on the direction of the counter).

The timer is able to generate PWM in edge-aligned mode or center-aligned mode depending on the CMS bits in the TIMx\_CR1 register.

**PWM edge-aligned mode**

- Upcounting configuration  
 Upcounting is active when the DIR bit in the TIMx\_CR1 register is low. Refer to the [Upcounting mode on page 273](#).  
 In the following example, we consider PWM mode 1. The reference PWM signal OCxREF is high as long as TIMx\_CNT < TIMx\_CCRx else it becomes low. If the compare value in TIMx\_CCRx is greater than the auto-reload value (in TIMx\_ARR) then OCxREF is held at '1'. If the compare value is 0 then OCxRef is held at '0'. [Figure 84](#) shows some edge-aligned PWM waveforms in an example where TIMx\_ARR=8.

**Figure 84. Edge-aligned PWM waveforms (ARR=8)**



- Downcounting configuration  
 Downcounting is active when DIR bit in TIMx\_CR1 register is high. Refer to the [Downcounting mode on page 276](#).  
 In PWM mode 1, the reference signal OCxRef is low as long as TIMx\_CNT > TIMx\_CCRx else it becomes high. If the compare value in TIMx\_CCRx is greater than the auto-reload value in TIMx\_ARR, then OCxREF is held at '1'. 0% PWM is not possible in this mode.

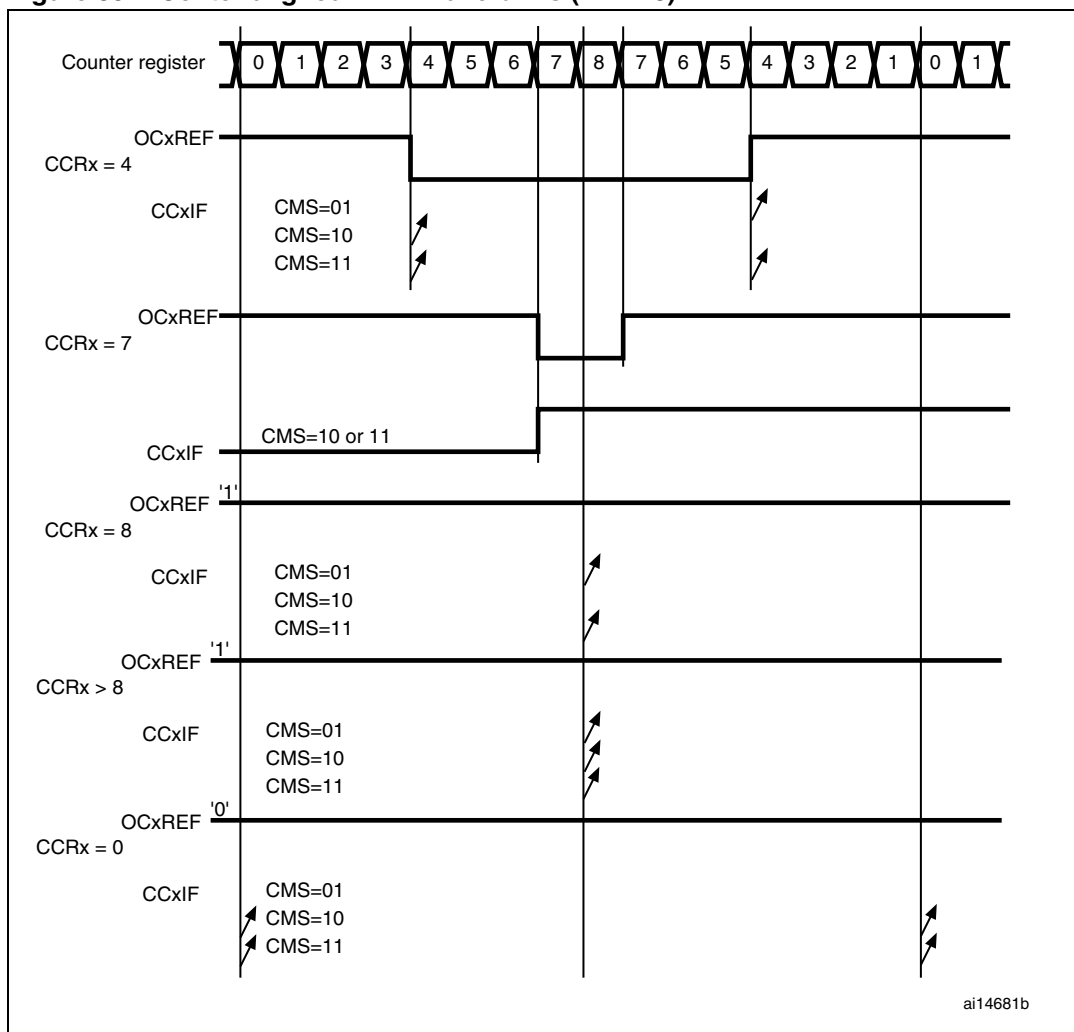
**PWM center-aligned mode**

Center-aligned mode is active when the CMS bits in TIMx\_CR1 register are different from '00' (all the remaining configurations having the same effect on the OCxRef/OCx signals). The compare flag is set when the counter counts up, when it counts down or both when it counts up and down depending on the CMS bits configuration. The direction bit (DIR) in the TIMx\_CR1 register is updated by hardware and must not be changed by software. Refer to the [Center-aligned mode \(up/down counting\) on page 278](#).

[Figure 85](#) shows some center-aligned PWM waveforms in an example where:

- TIMx\_ARR=8,
- PWM mode is the PWM mode 1,
- The flag is set when the counter counts down corresponding to the center-aligned mode 1 selected for CMS=01 in TIMx\_CR1 register.

Figure 85. Center-aligned PWM waveforms (ARR=8)



**Hints on using center-aligned mode:**

- When starting in center-aligned mode, the current up-down configuration is used. It means that the counter counts up or down depending on the value written in the DIR bit in the TIMx\_CR1 register. Moreover, the DIR and CMS bits must not be changed at the same time by the software.
- Writing to the counter while running in center-aligned mode is not recommended as it can lead to unexpected results. In particular:
  - The direction is not updated if you write a value in the counter that is greater than the auto-reload value (TIMx\_CNT>TIMx\_ARR). For example, if the counter was counting up, it continues to count up.
  - The direction is updated if you write 0 or write the TIMx\_ARR value in the counter but no Update Event UEV is generated.
- The safest way to use center-aligned mode is to generate an update by software (setting the UG bit in the TIMx\_EGR register) just before starting the counter and not to write the counter while it is running.

### 13.3.11 Complementary outputs and dead-time insertion

The advanced-control timers (TIM1&TIM8) can output two complementary signals and manage the switching-off and the switching-on instants of the outputs.

This time is generally known as dead-time and you have to adjust it depending on the devices you have connected to the outputs and their characteristics (intrinsic delays of level-shifters, delays due to power switches...)

You can select the polarity of the outputs (main output OCx or complementary OCxN) independently for each output. This is done by writing to the CCxP and CCxNP bits in the TIMx\_CCER register.

The complementary signals OCx and OCxN are activated by a combination of several control bits: the CCxE and CCxNE bits in the TIMx\_CCER register and the MOE, OISx, OISxN, OSSI and OSSR bits in the TIMx\_BDTR and TIMx\_CR2 registers. Refer to [Table 81: Output control bits for complementary OCx and OCxN channels with break feature on page 326](#) for more details. In particular, the dead-time is activated when switching to the IDLE state (MOE falling down to 0).

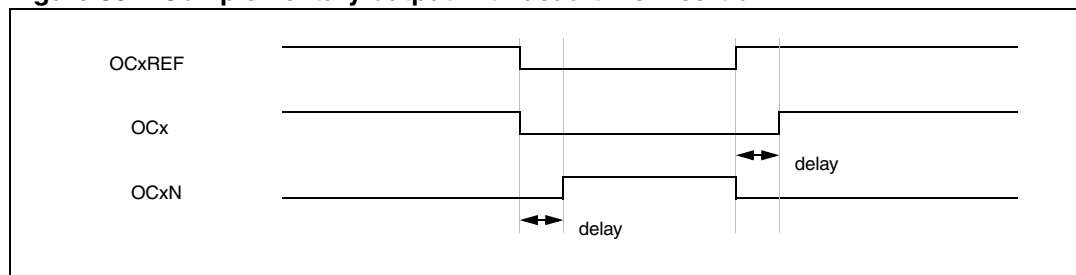
Dead-time insertion is enabled by setting both CCxE and CCxNE bits, and the MOE bit if the break circuit is present. There is one 10-bit dead-time generator for each channel. From a reference waveform OCxREF, it generates 2 outputs OCx and OCxN. If OCx and OCxN are active high:

- The OCx output signal is the same as the reference signal except for the rising edge, which is delayed relative to the reference rising edge.
- The OCxN output signal is the opposite of the reference signal except for the rising edge, which is delayed relative to the reference falling edge.

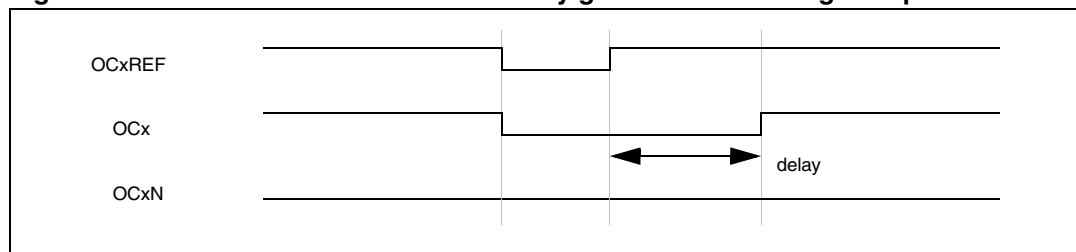
If the delay is greater than the width of the active output (OCx or OCxN) then the corresponding pulse is not generated.

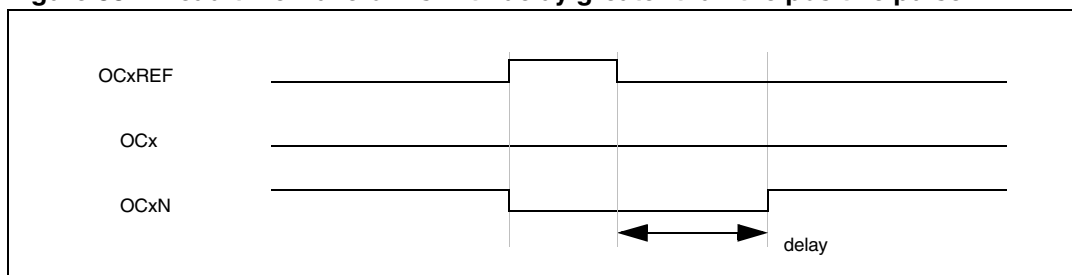
The following figures show the relationships between the output signals of the dead-time generator and the reference signal OCxREF. (we suppose CCxP=0, CCxNP=0, MOE=1, CCxE=1 and CCxNE=1 in these examples)

**Figure 86. Complementary output with dead-time insertion.**



**Figure 87. Dead-time waveforms with delay greater than the negative pulse.**



**Figure 88. Dead-time waveforms with delay greater than the positive pulse.**

The dead-time delay is the same for each of the channels and is programmable with the DTG bits in the TIMx\_BDTR register. Refer to [Section 13.4.18: TIM1&TIM8 break and dead-time register \(TIMx\\_BDTR\) on page 330](#) for delay calculation.

### Re-directing OCxREF to OCx or OCxN

In output mode (forced, output compare or PWM), OCxREF can be re-directed to the OCx output or to OCxN output by configuring the CCxE and CCxNE bits in the TIMx\_CCER register.

This allows you to send a specific waveform (such as PWM or static active level) on one output while the complementary remains at its inactive level. Other alternative possibilities are to have both outputs at inactive level or both outputs active and complementary with dead-time.

*Note:* When only OCxN is enabled (CCxE=0, CCxNE=1), it is not complemented and becomes active as soon as OCxREF is high. For example, if CCxNP=0 then OCxN=OCxRef. On the other hand, when both OCx and OCxN are enabled (CCxE=CCxNE=1) OCx becomes active when OCxREF is high whereas OCxN is complemented and becomes active when OCxREF is low.

### 13.3.12 Using the break function

When using the break function, the output enable signals and inactive levels are modified according to additional control bits (MOE, OSS1 and OSSR bits in the TIMx\_BDTR register, OISx and OISxN bits in the TIMx\_CR2 register). In any case, the OCx and OCxN outputs cannot be set both to active level at a given time. Refer to [Table 81: Output control bits for complementary OCx and OCxN channels with break feature on page 326](#) for more details.

The break source can be either the break input pin or a clock failure event, generated by the Clock Security System (CSS), from the Reset Clock Controller. For further information on the Clock Security System, refer to [Section 6.2.7: Clock security system \(CSS\) on page 88](#).

When exiting from reset, the break circuit is disabled and the MOE bit is low. You can enable the break function by setting the BKE bit in the TIMx\_BDTR register. The break input polarity can be selected by configuring the BKP bit in the same register. BKE and BKP can be modified at the same time. When the BKE and BKP bits are written, a delay of 1 APB clock cycle is applied before the writing is effective. Consequently, it is necessary to wait 1 APB clock period to correctly read back the bit after the write operation.

Because MOE falling edge can be asynchronous, a resynchronization circuit has been inserted between the actual signal (acting on the outputs) and the synchronous control bit (accessed in the TIMx\_BDTR register). It results in some delays between the asynchronous and the synchronous signals. In particular, if you write MOE to 1 whereas it was low, you

must insert a delay (dummy instruction) before reading it correctly. This is because you write the asynchronous signal and read the synchronous signal.

When a break occurs (selected level on the break input):

- The MOE bit is cleared asynchronously, putting the outputs in inactive state, idle state or in reset state (selected by the OSSI bit). This feature functions even if the MCU oscillator is off.
- Each output channel is driven with the level programmed in the OISx bit in the TIMx\_CR2 register as soon as MOE=0. If OSSI=0 then the timer releases the enable output else the enable output remains high.
- When complementary outputs are used:
  - The outputs are first put in reset state inactive state (depending on the polarity). This is done asynchronously so that it works even if no clock is provided to the timer.
  - If the timer clock is still present, then the dead-time generator is reactivated in order to drive the outputs with the level programmed in the OISx and OISxN bits after a dead-time. Even in this case, OCx and OCxN cannot be driven to their active level together. Note that because of the resynchronization on MOE, the dead-time duration is a bit longer than usual (around 2 ck\_tim clock cycles).
  - If OSSI=0 then the timer releases the enable outputs else the enable outputs remain or become high as soon as one of the CCxE or CCxNE bits is high.
- The break status flag (BIF bit in the TIMx\_SR register) is set. An interrupt can be generated if the BIE bit in the TIMx\_DIER register is set. A DMA request can be sent if the BDE bit in the TIMx\_DIER register is set.
- If the AOE bit in the TIMx\_BDTR register is set, the MOE bit is automatically set again at the next update event UEV. This can be used to perform a regulation, for instance. Else, MOE remains low until you write it to '1' again. In this case, it can be used for security and you can connect the break input to an alarm from power drivers, thermal sensors or any security components.

*Note:* The break inputs is acting on level. Thus, the MOE cannot be set while the break input is active (neither automatically nor by software). In the meantime, the status flag BIF cannot be cleared.

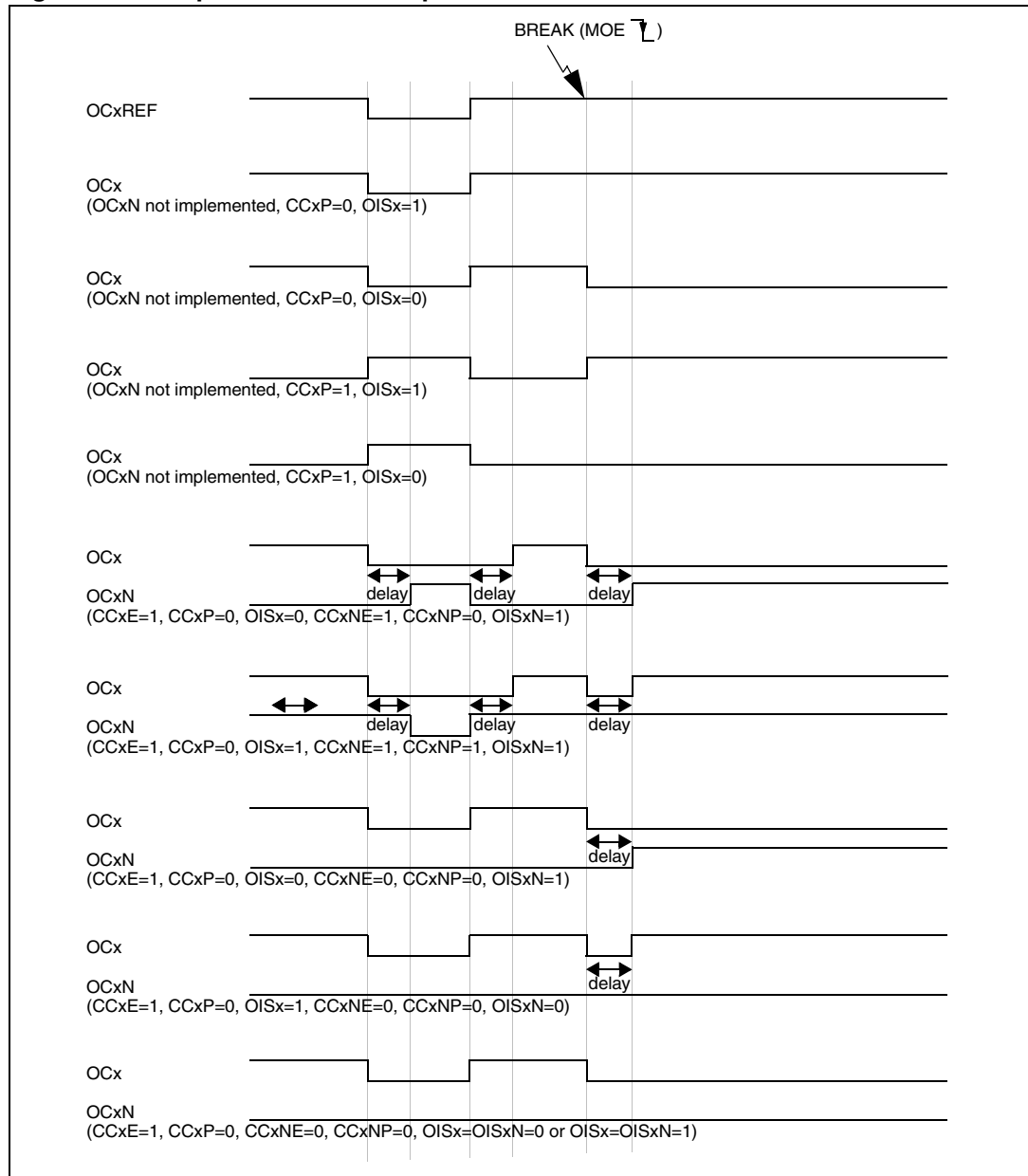
The break can be generated by the BRK input which has a programmable polarity and an enable bit BKE in the TIMx\_BDTR Register.

In addition to the break input and the output management, a write protection has been implemented inside the break circuit to safeguard the application. It allows you to freeze the configuration of several parameters (dead-time duration, OCx/OCxN polarities and state when disabled, OCxM configurations, break enable and polarity). You can choose from 3 levels of protection selected by the LOCK bits in the TIMx\_BDTR register. Refer to [Section 13.4.18: TIM1&TIM8 break and dead-time register \(TIMx\\_BDTR\) on page 330](#). The LOCK bits can be written only once after an MCU reset.

The [Figure 89](#) shows an example of behavior of the outputs in response to a break.



Figure 89. Output behavior in response to a break.



### 13.3.13 Clearing the OCxREF signal on an external event

The OCxREF signal for a given channel can be driven Low by applying a High level to the ETRF input (OCxCE enable bit of the corresponding TIMx\_CCMRx register set to '1'). The OCxREF signal remains Low until the next update event, UEV, occurs.

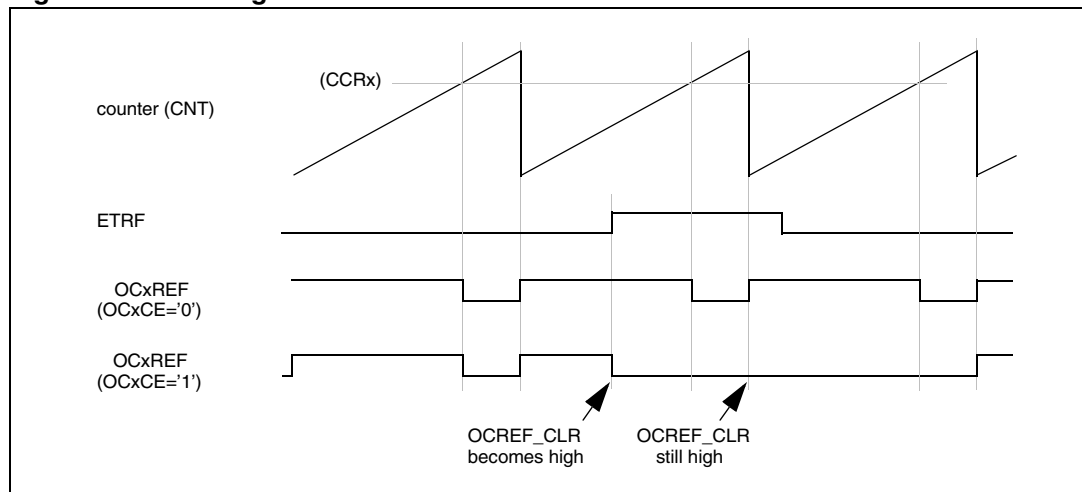
This function can only be used in output compare and PWM modes, and does not work in forced mode.

For example, the OCxREF signal) can be connected to the output of a comparator to be used for current handling. In this case, the ETR must be configured as follow:

1. The External Trigger Prescaler should be kept off: bits ETPS[1:0] of the TIMx\_SMCR register set to '00'.
2. The external clock mode 2 must be disabled: bit ECE of the TIMx\_SMCR register set to '0'.
3. The External Trigger Polarity (ETP) and the External Trigger Filter (ETF) can be configured according to the user needs.

Figure 90 shows the behavior of the OCxREF signal when the ETRF Input becomes High, for both values of the enable bit OCxCE. In this example, the timer TIMx is programmed in PWM mode.

**Figure 90. Clearing TIMx OCxREF**



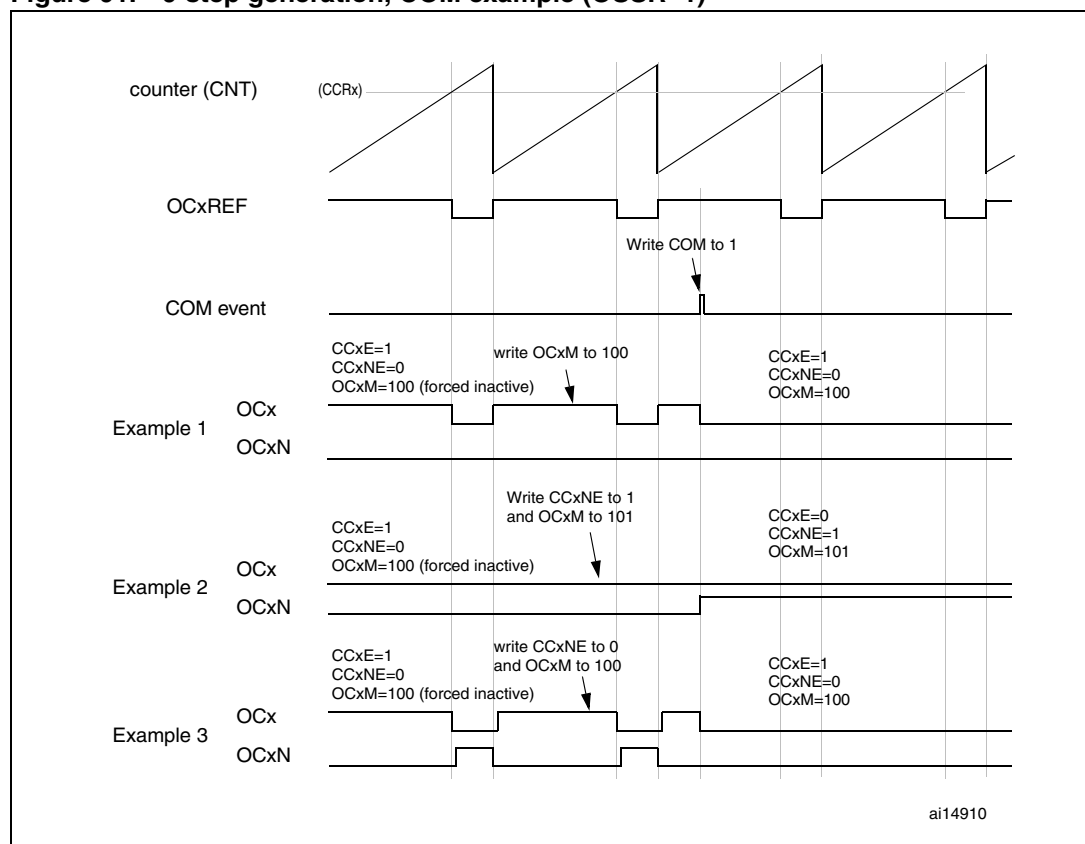
### 13.3.14 6-step PWM generation

When complementary outputs are used on a channel, preload bits are available on the OCxM, CCxE and CCxNE bits. The preload bits are transferred to the shadow bits at the COM commutation event. Thus you can program in advance the configuration for the next step and change the configuration of all the channels at the same time. COM can be generated by software by setting the COM bit in the TIMx\_EGR register or by hardware (on TRGI rising edge).

A flag is set when the COM event occurs (COMIF bit in the TIMx\_SR register), which can generate an interrupt (if the COMIE bit is set in the TIMx\_DIER register) or a DMA request (if the COMDE bit is set in the TIMx\_DIER register).

The [Figure 91](#) describes the behavior of the OCx and OCxN outputs when a COM event occurs, in 3 different examples of programmed configurations.

**Figure 91. 6-step generation, COM example (OSSR=1)**



### 13.3.15 One-pulse mode

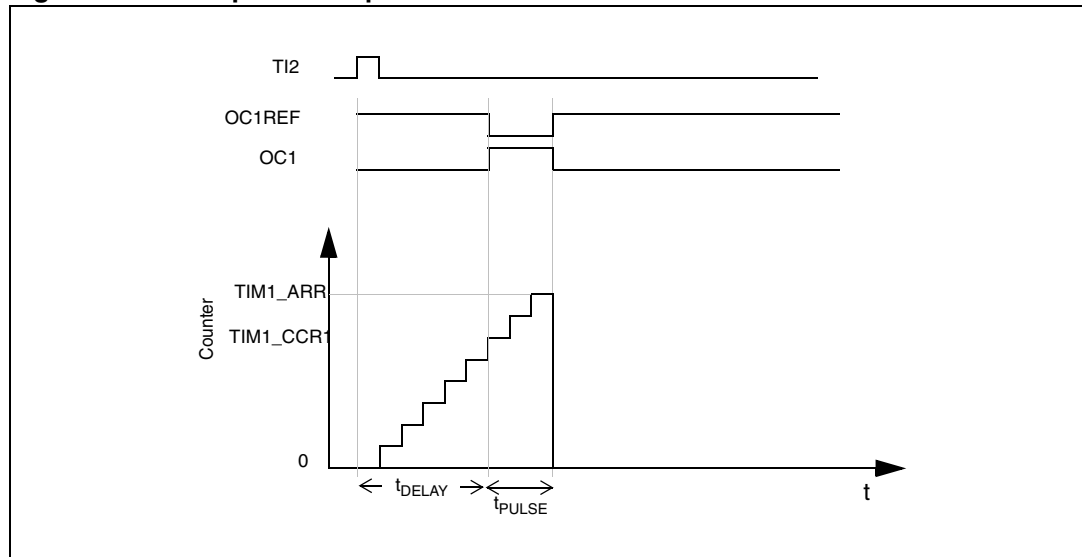
One-pulse mode (OPM) is a particular case of the previous modes. It allows the counter to be started in response to a stimulus and to generate a pulse with a programmable length after a programmable delay.

Starting the counter can be controlled through the slave mode controller. Generating the waveform can be done in output compare mode or PWM mode. You select One-pulse mode by setting the OPM bit in the TIMx\_CR1 register. This makes the counter stop automatically at the next update event UEV.

A pulse can be correctly generated only if the compare value is different from the counter initial value. Before starting (when the timer is waiting for the trigger), the configuration must be:

- In upcounting:  $CNT < CCRx \leq ARR$  (in particular,  $0 < CCRx$ )
- In downcounting:  $CNT > CCRx$

**Figure 92. Example of one pulse mode.**



For example you may want to generate a positive pulse on OC1 with a length of  $t_{PULSE}$  and after a delay of  $t_{DELAY}$  as soon as a positive edge is detected on the TI2 input pin.

Let's use TI2FP2 as trigger 1:

- Map TI2FP2 to TI2 by writing  $CC2S='01'$  in the TIMx\_CCMR1 register.
- TI2FP2 must detect a rising edge, write  $CC2P='0'$  in the TIMx\_CCER register.
- Configure TI2FP2 as trigger for the slave mode controller (TRGI) by writing  $TS='110'$  in the TIMx\_SMCR register.
- TI2FP2 is used to start the counter by writing  $SMS$  to  $'110'$  in the TIMx\_SMCR register (trigger mode).

The OPM waveform is defined by writing the compare registers (taking into account the clock frequency and the counter prescaler).

- The  $t_{\text{DELAY}}$  is defined by the value written in the TIMx\_CCR1 register.
- The  $t_{\text{PULSE}}$  is defined by the difference between the auto-reload value and the compare value (TIMx\_ARR - TIMx\_CCR1).
- Let's say you want to build a waveform with a transition from '0' to '1' when a compare match occurs and a transition from '1' to '0' when the counter reaches the auto-reload value. To do this you enable PWM mode 2 by writing OC1M=111 in the TIMx\_CCMR1 register. You can optionally enable the preload registers by writing OC1PE='1' in the TIMx\_CCMR1 register and ARPE in the TIMx\_CR1 register. In this case you have to write the compare value in the TIMx\_CCR1 register, the auto-reload value in the TIMx\_ARR register, generate an update by setting the UG bit and wait for external trigger event on TI2. CC1P is written to '0' in this example.

In our example, the DIR and CMS bits in the TIMx\_CR1 register should be low.

You only want 1 pulse(Single mode), so you write '1' in the OPM bit in the TIMx\_CR1 register to stop the counter at the next update event (when the counter rolls over from the auto-reload value back to 0). When OPM bit in the TIMx\_CR1 register is set to '0', so the Repetitive Mode is selected.

#### Particular case: OCx fast enable:

In One-pulse mode, the edge detection on Tlx input set the CEN bit which enables the counter. Then the comparison between the counter and the compare value makes the output toggle. But several clock cycles are needed for these operations and it limits the minimum delay  $t_{\text{DELAY min}}$  we can get.

If you want to output a waveform with the minimum delay, you can set the OCxFE bit in the TIMx\_CCMRx register. Then OCxRef (and OCx) are forced in response to the stimulus, without taking in account the comparison. Its new level is the same as if a compare match had occurred. OCxFE acts only if the channel is configured in PWM1 or PWM2 mode.

### 13.3.16 Encoder interface mode

To select Encoder Interface mode write SMS='001' in the TIMx\_SMCR register if the counter is counting on TI2 edges only, SMS='010' if it is counting on TI1 edges only and SMS='011' if it is counting on both TI1 and TI2 edges.

Select the TI1 and TI2 polarity by programming the CC1P and CC2P bits in the TIMx\_CCER register. When needed, you can program the input filter as well.

The two inputs TI1 and TI2 are used to interface to an incremental encoder. Refer to [Table 79](#). The counter is clocked by each valid transition on TI1FP1 or TI2FP2 (TI1 and TI2 after input filter and polarity selection, TI1FP1=TI1 if not filtered and not inverted, TI2FP2=TI2 if not filtered and not inverted) assuming that it is enabled (CEN bit in TIMx\_CR1 register written to '1'). The sequence of transitions of the two inputs is evaluated and generates count pulses as well as the direction signal. Depending on the sequence the counter counts up or down, the DIR bit in the TIMx\_CR1 register is modified by hardware accordingly. The DIR bit is calculated at each transition on any input (TI1 or TI2), whatever the counter is counting on TI1 only, TI2 only or both TI1 and TI2.

Encoder interface mode acts simply as an external clock with direction selection. This means that the counter just counts continuously between 0 and the auto-reload value in the TIMx\_ARR register (0 to ARR or ARR down to 0 depending on the direction). So you must configure TIMx\_ARR before starting. in the same way, the capture, compare, prescaler,

repetition counter, trigger output features continue to work as normal. Encoder mode and External clock mode 2 are not compatible and must not be selected together.

In this mode, the counter is modified automatically following the speed and the direction of the incremental encoder and its content, therefore, always represents the encoder's position. The count direction correspond to the rotation direction of the connected sensor. The table summarizes the possible combinations, assuming T11 and T12 don't switch at the same time.

**Table 79. Counting direction versus encoder signals**

Active edge	Level on opposite signal (TI1FP1 for T12, TI2FP2 for T11)	TI1FP1 signal		TI2FP2 signal	
		Rising	Falling	Rising	Falling
Counting on T11 only	High	Down	Up	No Count	No Count
	Low	Up	Down	No Count	No Count
Counting on T12 only	High	No Count	No Count	Up	Down
	Low	No Count	No Count	Down	Up
Counting on T11 and T12	High	Down	Up	Up	Down
	Low	Up	Down	Down	Up

An external incremental encoder can be connected directly to the MCU without external interface logic. However, comparators are normally be used to convert the encoder's differential outputs to digital signals. This greatly increases noise immunity. The third encoder output which indicate the mechanical zero position, may be connected to an external interrupt input and trigger a counter reset.

The [Figure 93](#) gives an example of counter operation, showing count signal generation and direction control. It also shows how input jitter is compensated where both edges are selected. This might occur if the sensor is positioned near to one of the switching points. For this example we assume that the configuration is the following:

- CC1S='01' (TIMx\_CCMR1 register, TI1FP1 mapped on T11).
- CC2S='01' (TIMx\_CCMR2 register, TI1FP2 mapped on T12).
- CC1P='0' (TIMx\_CCER register, TI1FP1 non-inverted, TI1FP1=T11).
- CC2P='0' (TIMx\_CCER register, TI1FP2 non-inverted, TI1FP2= T12).
- SMS='011' (TIMx\_SMCR register, both inputs are active on both rising and falling edges).
- CEN='1' (TIMx\_CR1 register, Counter enabled).

**Figure 93. Example of counter operation in encoder interface mode.**

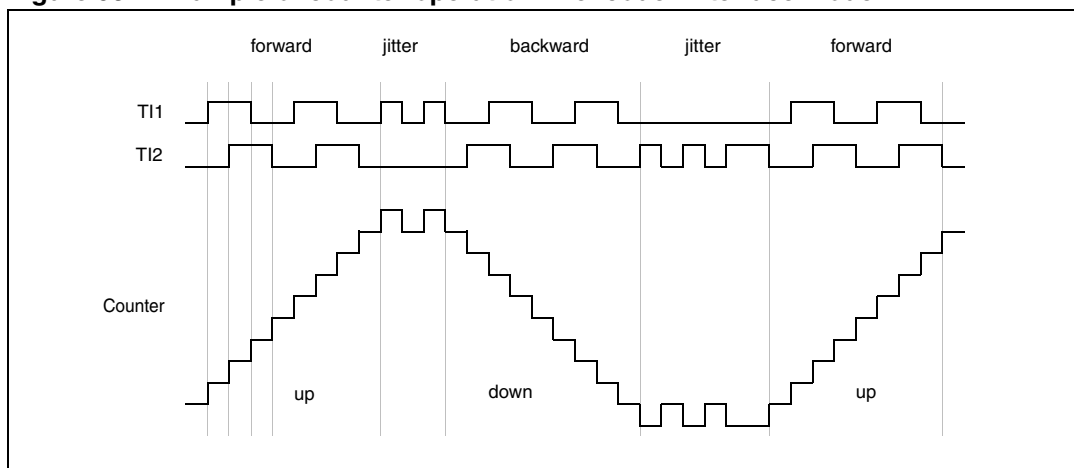
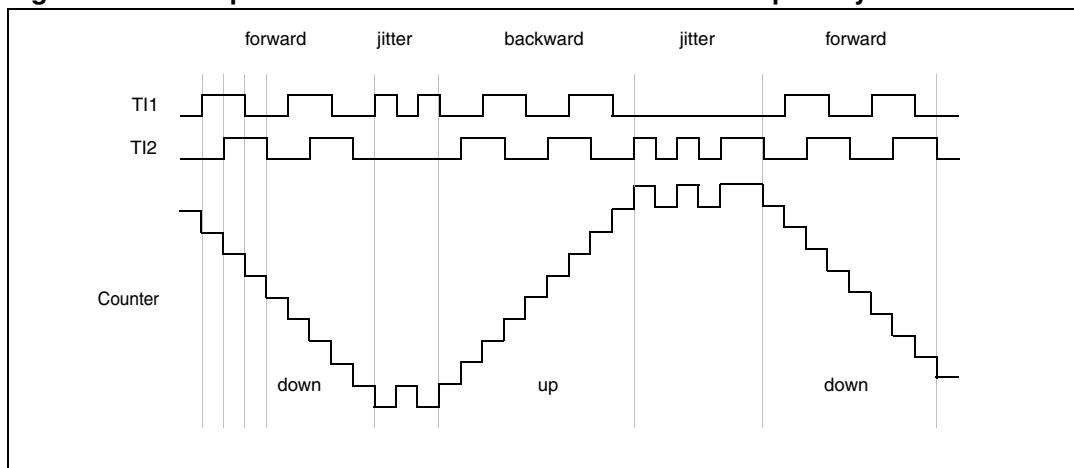


Figure 94 gives an example of counter behavior when TI1FP1 polarity is inverted (same configuration as above except CC1P='1').

**Figure 94. Example of encoder interface mode with TI1FP1 polarity inverted.**



The timer, when configured in Encoder Interface mode provides information on the sensor's current position. You can obtain dynamic information (speed, acceleration, deceleration) by measuring the period between two encoder events using a second timer configured in capture mode. The output of the encoder which indicates the mechanical zero can be used for this purpose. Depending on the time between two events, the counter can also be read at regular times. You can do this by latching the counter value into a third input capture register if available (then the capture signal must be periodic and can be generated by another timer). when available, it is also possible to read its value through a DMA request generated by a real-time clock.

### 13.3.17 Timer input XOR function

The TI1S bit in the TIMx\_CR2 register, allows the input filter of channel 1 to be connected to the output of a XOR gate, combining the three input pins TIMx\_CH1, TIMx\_CH2 and TIMx\_CH3.

The XOR output can be used with all the timer input functions such as trigger or input capture. An example of this feature used to interface Hall sensors is given in [Section 13.3.18](#) below.

### 13.3.18 Interfacing with Hall sensors

This is done using the advanced-control timers (TIM1 or TIM8) to generate PWM signals to drive the motor and another timer TIMx (TIM2, TIM3, TIM4 or TIM5) referred to as “interfacing timer” in [Figure 95](#). The “interfacing timer” captures the 3 timer input pins (CC1, CC2, CC3) connected through a XOR to the TI1 input channel (selected by setting the TI1S bit in the TIMx\_CR2 register).

The slave mode controller is configured in reset mode; the slave input is TI1F\_ED. Thus, each time one of the 3 inputs toggles, the counter restarts counting from 0. This creates a time base triggered by any change on the Hall inputs.

On the “interfacing timer”, capture/compare channel 1 is configured in capture mode, capture signal is TRC (See [Figure 78: Capture/compare channel \(example: channel 1 input stage\) on page 286](#)). The captured value, which corresponds to the time elapsed between 2 changes on the inputs, gives information about motor speed.

The “interfacing timer” can be used in output mode to generate a pulse which changes the configuration of the channels of the advanced-control timer (TIM1 or TIM8) (by triggering a COM event). The TIM1 timer is used to generate PWM signals to drive the motor. To do this, the interfacing timer channel must be programmed so that a positive pulse is generated after a programmed delay (in output compare or PWM mode). This pulse is sent to the advanced-control timer (TIM1 or TIM8) through the TRGO output.

Example: you want to change the PWM configuration of your advanced-control timer TIM1 after a programmed delay each time a change occurs on the Hall inputs connected to one of the TIMx timers.

- Configure 3 timer inputs ORed to the TI1 input channel by writing the TI1S bit in the TIMx\_CR2 register to ‘1’,
- Program the time base: write the TIMx\_ARR to the max value (the counter must be cleared by the TI1 change. Set the prescaler to get a maximum counter period longer than the time between 2 changes on the sensors,
- Program the channel 1 in capture mode (TRC selected): write the CC1S bits in the TIMx\_CCMR1 register to ‘01’. You can also program the digital filter if needed,
- Program the channel 2 in PWM 2 mode with the desired delay: write the OC2M bits to ‘111’ and the CC2S bits to ‘00’ in the TIMx\_CCMR1 register,
- Select OC2REF as trigger output on TRGO: write the MMS bits in the TIMx\_CR2 register to ‘101’,

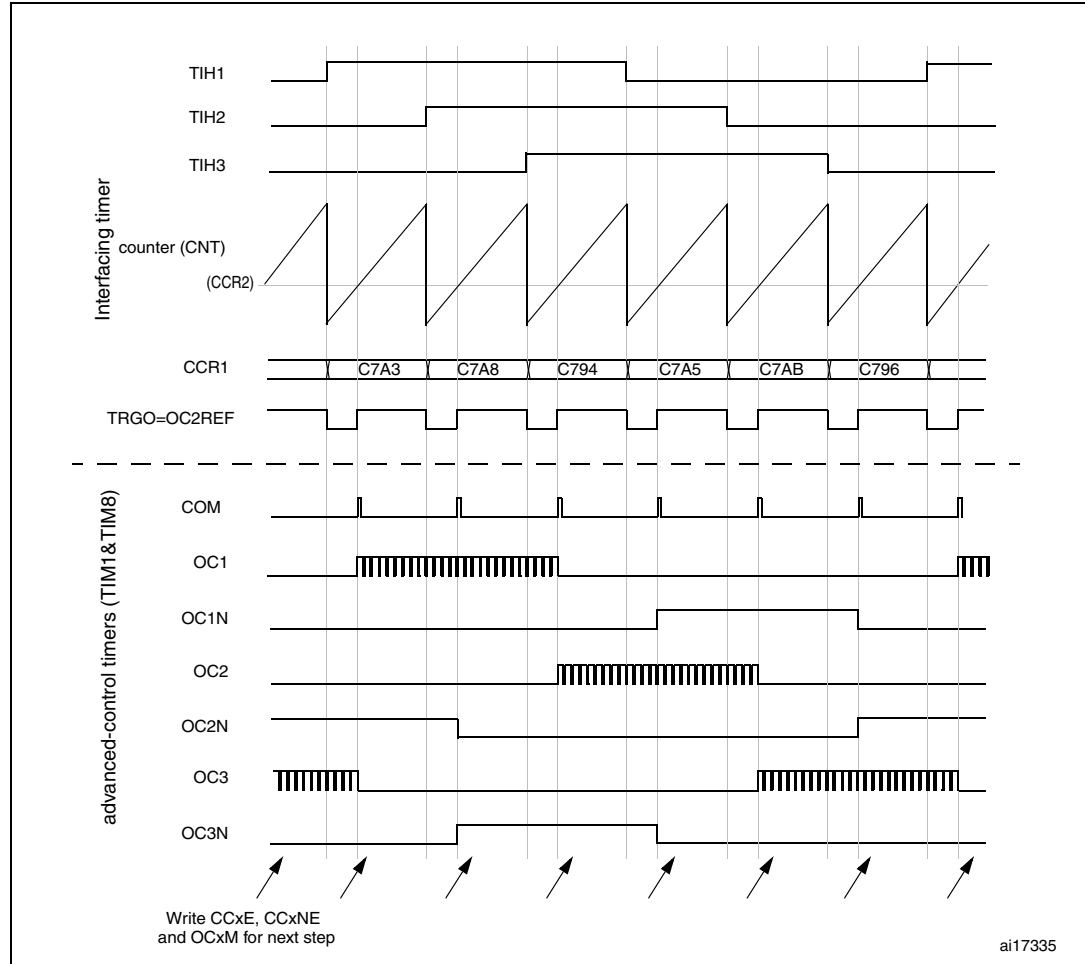
In the advanced-control timer TIM1, the right ITR input must be selected as trigger input, the timer is programmed to generate PWM signals, the capture/compare control signals are preloaded (CCPC=1 in the TIMx\_CR2 register) and the COM event is controlled by the trigger input (CCUS=1 in the TIMx\_CR2 register). The PWM control bits (CCxE, OCxM) are



written after a COM event for the next step (this can be done in an interrupt subroutine generated by the rising edge of OC2REF).

The [Figure 95](#) describes this example.

**Figure 95. Example of hall sensor interface**



### 13.3.19 TIMx and external trigger synchronization

The TIMx timer can be synchronized with an external trigger in several modes: Reset mode, Gated mode and Trigger mode.

#### Slave mode: Reset mode

The counter and its prescaler can be reinitialized in response to an event on a trigger input. Moreover, if the URS bit from the TIMx\_CR1 register is low, an update event UEV is generated. Then all the preloaded registers (TIMx\_ARR, TIMx\_CCRx) are updated.

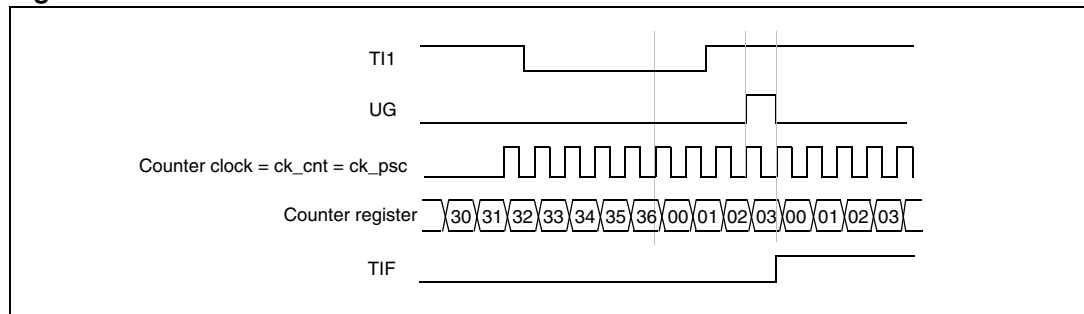
In the following example, the upcounter is cleared in response to a rising edge on TI1 input:

- Configure the channel 1 to detect rising edges on TI1. Configure the input filter duration (in this example, we don't need any filter, so we keep IC1F=0000). The capture prescaler is not used for triggering, so you don't need to configure it. The CC1S bits select the input capture source only, CC1S = 01 in the TIMx\_CCMR1 register. Write CC1P=0 in TIMx\_CCER register to validate the polarity (and detect rising edges only).
- Configure the timer in reset mode by writing SMS=100 in TIMx\_SMCR register. Select TI1 as the input source by writing TS=101 in TIMx\_SMCR register.
- Start the counter by writing CEN=1 in the TIMx\_CR1 register.

The counter starts counting on the internal clock, then behaves normally until TI1 rising edge. When TI1 rises, the counter is cleared and restarts from 0. In the meantime, the trigger flag is set (TIF bit in the TIMx\_SR register) and an interrupt request, or a DMA request can be sent if enabled (depending on the TIE and TDE bits in TIMx\_DIER register).

The following figure shows this behavior when the auto-reload register TIMx\_ARR=0x36. The delay between the rising edge on TI1 and the actual reset of the counter is due to the resynchronization circuit on TI1 input.

**Figure 96. Control circuit in reset mode**



**Slave mode: Gated mode**

The counter can be enabled depending on the level of a selected input.

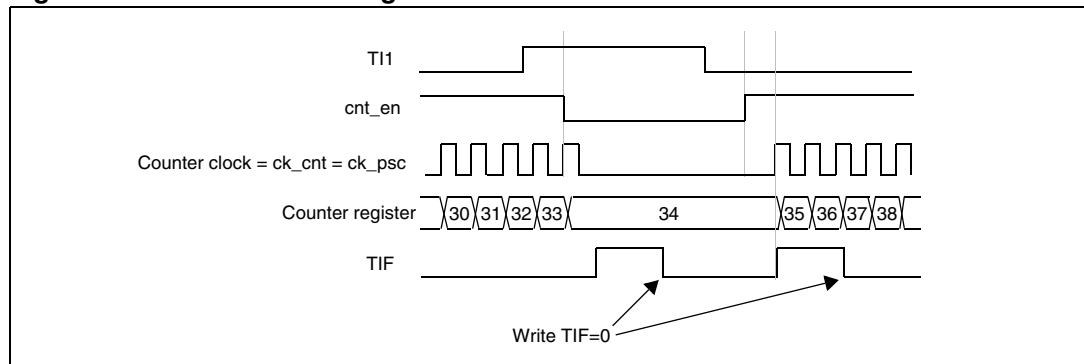
In the following example, the upcounter counts only when TI1 input is low:

- Configure the channel 1 to detect low levels on TI1. Configure the input filter duration (in this example, we don't need any filter, so we keep IC1F=0000). The capture prescaler is not used for triggering, so you don't need to configure it. The CC1S bits select the input capture source only, CC1S=01 in TIMx\_CCMR1 register. Write CC1P=1 in TIMx\_CCER register to validate the polarity (and detect low level only).
- Configure the timer in gated mode by writing SMS=101 in TIMx\_SMCR register. Select TI1 as the input source by writing TS=101 in TIMx\_SMCR register.
- Enable the counter by writing CEN=1 in the TIMx\_CR1 register (in gated mode, the counter doesn't start if CEN=0, whatever is the trigger input level).

The counter starts counting on the internal clock as long as TI1 is low and stops as soon as TI1 becomes high. The TIF flag in the TIMx\_SR register is set both when the counter starts or stops.

The delay between the rising edge on TI1 and the actual stop of the counter is due to the resynchronization circuit on TI1 input.

**Figure 97. Control circuit in gated mode**



**Slave mode: Trigger mode**

The counter can start in response to an event on a selected input.

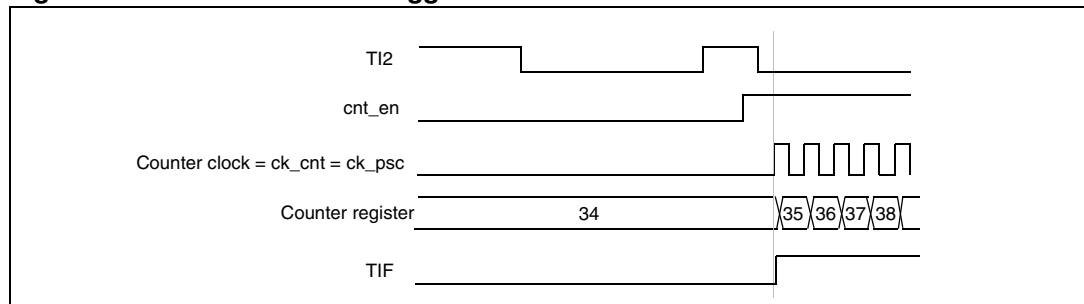
In the following example, the upcounter starts in response to a rising edge on TI2 input:

- Configure the channel 2 to detect rising edges on TI2. Configure the input filter duration (in this example, we don't need any filter, so we keep IC2F=0000). The capture prescaler is not used for triggering, so you don't need to configure it. The CC2S bits are configured to select the input capture source only, CC2S=01 in TIMx\_CCMR1 register. Write CC2P=1 in TIMx\_CCER register to validate the polarity (and detect low level only).
- Configure the timer in trigger mode by writing SMS=110 in TIMx\_SMCR register. Select TI2 as the input source by writing TS=110 in TIMx\_SMCR register.

When a rising edge occurs on TI2, the counter starts counting on the internal clock and the TIF flag is set.

The delay between the rising edge on TI2 and the actual start of the counter is due to the resynchronization circuit on TI2 input.

**Figure 98. Control circuit in trigger mode**



**Slave mode: external clock mode 2 + trigger mode**

The external clock mode 2 can be used in addition to another slave mode (except external clock mode 1 and encoder mode). In this case, the ETR signal is used as external clock input, and another input can be selected as trigger input (in reset mode, gated mode or trigger mode). It is recommended not to select ETR as TRGI through the TS bits of TIMx\_SMCR register.

In the following example, the upcounter is incremented at each rising edge of the ETR signal as soon as a rising edge of TI1 occurs:

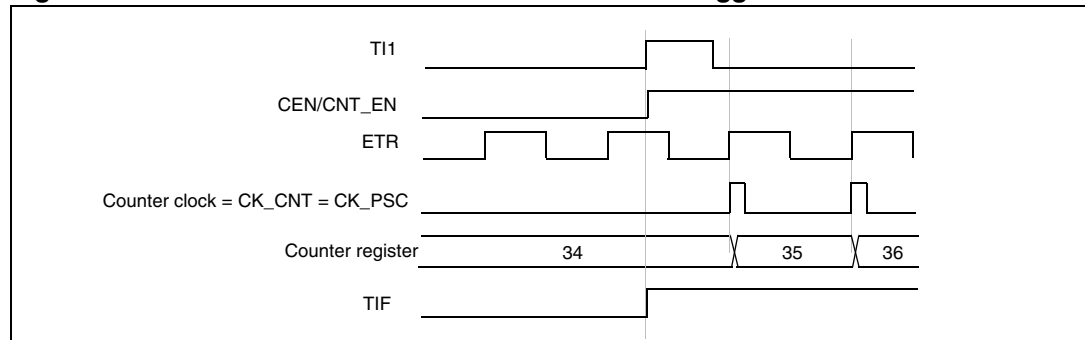
1. Configure the external trigger input circuit by programming the TIMx\_SMCR register as follows:
  - ETF = 0000: no filter
  - ETPS=00: prescaler disabled
  - ETP=0: detection of rising edges on ETR and ECE=1 to enable the external clock mode 2.

2. Configure the channel 1 as follows, to detect rising edges on TI:
  - IC1F=0000: no filter.
  - The capture prescaler is not used for triggering and does not need to be configured.
  - CC1S=01 in TIMx\_CCMR1 register to select only the input capture source
  - CC1P=0 in TIMx\_CCER register to validate the polarity (and detect rising edge only).
3. Configure the timer in trigger mode by writing SMS=110 in TIMx\_SMCR register. Select TI1 as the input source by writing TS=101 in TIMx\_SMCR register.

A rising edge on TI1 enables the counter and sets the TIF flag. The counter then counts on ETR rising edges.

The delay between the rising edge of the ETR signal and the actual reset of the counter is due to the resynchronization circuit on ETRP input.

**Figure 99. Control circuit in external clock mode 2 + trigger mode**



### 13.3.20 Timer synchronization

The TIM timers are linked together internally for timer synchronization or chaining. Refer to [Section 14.3.15: Timer synchronization on page 365](#) for details.

### 13.3.21 Debug mode

When the microcontroller enters debug mode (Cortex-M3 core halted), the TIMx counter either continues to work normally or stops, depending on DBG\_TIMx\_STOP configuration bit in DBG module. For more details, refer to [Section 30.16.2: Debug support for timers, watchdog, bxCAN and I2C](#).

## 13.4 TIM1&TIM8 registers

Refer to [Section 1.1 on page 40](#) for a list of abbreviations used in register descriptions.  
 The peripheral registers can be accessed by half-words (16-bit) or words (32-bit).

### 13.4.1 TIM1&TIM8 control register 1 (TIMx\_CR1)

Address offset: 0x00

Reset value: 0x0000

15	14	13	12	11	10	9	8	7	6	5	4	3	2	1	0
Reserved						CKD[1:0]		ARPE	CMS[1:0]		DIR	OPM	URS	UDIS	CEN
						rw	rw	rw	rw	rw	rw	rw	rw	rw	rw

Bits 15:10 Reserved, always read as 0

Bits 9:8 **CKD[1:0]**: Clock division

This bit-field indicates the division ratio between the timer clock (CK\_INT) frequency and the dead-time and sampling clock ( $t_{DTS}$ ) used by the dead-time generators and the digital filters (ETR, TIx),

00:  $t_{DTS}=t_{CK\_INT}$

01:  $t_{DTS}=2*t_{CK\_INT}$

10:  $t_{DTS}=4*t_{CK\_INT}$

11: Reserved, do not program this value

Bit 7 **ARPE**: Auto-reload preload enable

0: TIMx\_ARR register is not buffered

1: TIMx\_ARR register is buffered

Bits 6:5 **CMS[1:0]**: Center-aligned mode selection

00: Edge-aligned mode. The counter counts up or down depending on the direction bit (DIR).

01: Center-aligned mode 1. The counter counts up and down alternatively. Output compare interrupt flags of channels configured in output (CCxS=00 in TIMx\_CCMRx register) are set only when the counter is counting down.

10: Center-aligned mode 2. The counter counts up and down alternatively. Output compare interrupt flags of channels configured in output (CCxS=00 in TIMx\_CCMRx register) are set only when the counter is counting up.

11: Center-aligned mode 3. The counter counts up and down alternatively. Output compare interrupt flags of channels configured in output (CCxS=00 in TIMx\_CCMRx register) are set both when the counter is counting up or down.

*Note: It is not allowed to switch from edge-aligned mode to center-aligned mode as long as the counter is enabled (CEN=1)*

Bit 4 **DIR**: Direction

0: Counter used as upcounter

1: Counter used as downcounter

*Note: This bit is read only when the timer is configured in Center-aligned mode or Encoder mode.*

Bit 3 **OPM**: One pulse mode

0: Counter is not stopped at update event

1: Counter stops counting at the next update event (clearing the bit CEN)

Bit 2 **URS**: Update request source

This bit is set and cleared by software to select the UEV event sources.

0: Any of the following events generate an update interrupt or DMA request if enabled. These events can be:

- Counter overflow/underflow
- Setting the UG bit
- Update generation through the slave mode controller

1: Only counter overflow/underflow generates an update interrupt or DMA request if enabled.

Bit 1 **UDIS**: Update disable

This bit is set and cleared by software to enable/disable UEV event generation.

0: UEV enabled. The Update (UEV) event is generated by one of the following events:

- Counter overflow/underflow
- Setting the UG bit
- Update generation through the slave mode controller

Buffered registers are then loaded with their preload values.

1: UEV disabled. The Update event is not generated, shadow registers keep their value (ARR, PSC, CCRx). However the counter and the prescaler are reinitialized if the UG bit is set or if a hardware reset is received from the slave mode controller.

Bit 0 **CEN**: Counter enable

0: Counter disabled

1: Counter enabled

*Note: External clock, gated mode and encoder mode can work only if the CEN bit has been previously set by software. However trigger mode can set the CEN bit automatically by hardware.*

### 13.4.2 TIM1&TIM8 control register 2 (TIMx\_CR2)

Address offset: 0x04

Reset value: 0x0000

	15	14	13	12	11	10	9	8	7	6	5	4	3	2	1	0
Res.	OIS4	OIS3N	OIS3	OIS2N	OIS2	OIS1N	OIS1	TI1S		MMS[2:0]			CCDS	CCUS	Res.	CCPC
	rw	rw	rw	rw	rw	rw	rw	rw	rw	rw	rw	rw	rw	rw		rw

Bit 15 Reserved, always read as 0

Bit 14 **OIS4**: Output Idle state 4 (OC4 output)

refer to OIS1 bit

Bit 13 **OIS3N**: Output Idle state 3 (OC3N output)

refer to OIS1N bit

Bit 12 **OIS3**: Output Idle state 3 (OC3 output)

refer to OIS1 bit

Bit 11 **OIS2N**: Output Idle state 2 (OC2N output)

refer to OIS1N bit

Bit 10 **OIS2**: Output Idle state 2 (OC2 output)

refer to OIS1 bit

Bit 9 **OIS1N**: Output Idle state 1 (OC1N output)

- 0: OC1N=0 after a dead-time when MOE=0
- 1: OC1N=1 after a dead-time when MOE=0

*Note: This bit can not be modified as long as LOCK level 1, 2 or 3 has been programmed (LOCK bits in TIMx\_BDTR register).*

Bit 8 **OIS1**: Output Idle state 1 (OC1 output)

- 0: OC1=0 (after a dead-time if OC1N is implemented) when MOE=0
- 1: OC1=1 (after a dead-time if OC1N is implemented) when MOE=0

*Note: This bit can not be modified as long as LOCK level 1, 2 or 3 has been programmed (LOCK bits in TIMx\_BDTR register).*

Bit 7 **TI1S**: TI1 selection

- 0: The TIMx\_CH1 pin is connected to TI1 input
- 1: The TIMx\_CH1, CH2 and CH3 pins are connected to the TI1 input (XOR combination)

Bits 6:4 **MMS[1:0]**: Master mode selection

These bits allow to select the information to be sent in master mode to slave timers for synchronization (TRGO). The combination is as follows:

000: **Reset** - the UG bit from the TIMx\_EGR register is used as trigger output (TRGO). If the reset is generated by the trigger input (slave mode controller configured in reset mode) then the signal on TRGO is delayed compared to the actual reset.

001: **Enable** - the Counter Enable signal CNT\_EN is used as trigger output (TRGO). It is useful to start several timers at the same time or to control a window in which a slave timer is enable. The Counter Enable signal is generated by a logic OR between CEN control bit and the trigger input when configured in gated mode. When the Counter Enable signal is controlled by the trigger input, there is a delay on TRGO, except if the master/slave mode is selected (see the MSM bit description in TIMx\_SMCR register).

010: **Update** - The update event is selected as trigger output (TRGO). For instance a master timer can then be used as a prescaler for a slave timer.

011: **Compare Pulse** - The trigger output send a positive pulse when the CC1IF flag is to be set (even if it was already high), as soon as a capture or a compare match occurred. (TRGO).

100: **Compare** - OC1REF signal is used as trigger output (TRGO)

101: **Compare** - OC2REF signal is used as trigger output (TRGO)

110: **Compare** - OC3REF signal is used as trigger output (TRGO)

111: **Compare** - OC4REF signal is used as trigger output (TRGO)

Bit 3 **CCDS**: Capture/compare DMA selection

- 0: CCx DMA request sent when CCx event occurs
- 1: CCx DMA requests sent when update event occurs

Bit 2 **CCUS**: Capture/compare control update selection

- 0: When capture/compare control bits are preloaded (CCPC=1), they are updated by setting the COMG bit only
- 1: When capture/compare control bits are preloaded (CCPC=1), they are updated by setting the COMG bit or when an rising edge occurs on TRGI

*Note: This bit acts only on channels that have a complementary output.*

Bit 1 Reserved, always read as 0

Bit 0 **CCPC**: Capture/compare preloaded control

- 0: CCxE, CCxNE and OCxM bits are not preloaded
- 1: CCxE, CCxNE and OCxM bits are preloaded, after having been written, they are updated only when COM bit is set.

*Note: This bit acts only on channels that have a complementary output.*



### 13.4.3 TIM1&TIM8 slave mode control register (TIMx\_SMCR)

Address offset: 0x08

Reset value: 0x0000

15	14	13	12	11	10	9	8	7	6	5	4	3	2	1	0
ETP	ECE	ETPS[1:0]		ETF[3:0]				MSM	TS[2:0]			Res.	SMS[2:0]		
rw	rw	rw	rw	rw	rw	rw	rw	rw	rw	rw	rw	Res.	rw	rw	rw

Bit 15 **ETP**: External trigger polarity

This bit selects whether ETR or  $\overline{ETR}$  is used for trigger operations

0: ETR is non-inverted, active at high level or rising edge.

1: ETR is inverted, active at low level or falling edge.

Bit 14 **ECE**: External clock enable

This bit enables External clock mode 2.

0: External clock mode 2 disabled

1: External clock mode 2 enabled. The counter is clocked by any active edge on the ETRF signal.

*Note:* **1:** Setting the ECE bit has the same effect as selecting external clock mode 1 with TRGI connected to ETRF (SMS=111 and TS=111).

**2:** It is possible to simultaneously use external clock mode 2 with the following slave modes: reset mode, gated mode and trigger mode. Nevertheless, TRGI must not be connected to ETRF in this case (TS bits must not be 111).

**3:** If external clock mode 1 and external clock mode 2 are enabled at the same time, the external clock input is ETRF.

Bits 13:12 **ETPS[1:0]**: External trigger prescaler

External trigger signal ETRP frequency must be at most 1/4 of TIMxCLK frequency. A prescaler can be enabled to reduce ETRP frequency. It is useful when inputting fast external clocks.

00: Prescaler OFF

01: ETRP frequency divided by 2

10: ETRP frequency divided by 4

11: ETRP frequency divided by 8

Bits 11:8 **ETF[3:0]**: External trigger filter

This bit-field then defines the frequency used to sample ETRP signal and the length of the digital filter applied to ETRP. The digital filter is made of an event counter in which N events are needed to validate a transition on the output:

0000: No filter, sampling is done at  $f_{DTS}$

0001:  $f_{SAMPLING}=f_{CK\_INT}$ , N=2

0010:  $f_{SAMPLING}=f_{CK\_INT}$ , N=4

0011:  $f_{SAMPLING}=f_{CK\_INT}$ , N=8

0100:  $f_{SAMPLING}=f_{DTS}/2$ , N=6

0101:  $f_{SAMPLING}=f_{DTS}/2$ , N=8

0110:  $f_{SAMPLING}=f_{DTS}/4$ , N=6

0111:  $f_{SAMPLING}=f_{DTS}/4$ , N=8

1000:  $f_{SAMPLING}=f_{DTS}/8$ , N=6

1001:  $f_{SAMPLING}=f_{DTS}/8$ , N=8

1010:  $f_{SAMPLING}=f_{DTS}/16$ , N=5

1011:  $f_{SAMPLING}=f_{DTS}/16$ , N=6

1100:  $f_{SAMPLING}=f_{DTS}/16$ , N=8

1101:  $f_{SAMPLING}=f_{DTS}/32$ , N=5

1110:  $f_{SAMPLING}=f_{DTS}/32$ , N=6

1111:  $f_{SAMPLING}=f_{DTS}/32$ , N=8

Bit 7 **MSM**: Master/slave mode

0: No action

1: The effect of an event on the trigger input (TRGI) is delayed to allow a perfect synchronization between the current timer and its slaves (through TRGO). It is useful if we want to synchronize several timers on a single external event.

Bits 6:4 **TS[2:0]**: Trigger selection

This bit-field selects the trigger input to be used to synchronize the counter.

000: Internal Trigger 0 (ITR0)

001: Internal Trigger 1 (ITR1)

010: Internal Trigger 2 (ITR2)

011: Internal Trigger 3 (ITR3)

100: TI1 Edge Detector (TI1F\_ED)

101: Filtered Timer Input 1 (TI1FP1)

110: Filtered Timer Input 2 (TI2FP2)

111: External Trigger input (ETRF)

See [Table 80: TIMx Internal trigger connection on page 315](#) for more details on ITRx meaning for each Timer.

*Note: These bits must be changed only when they are not used (e.g. when SMS=000) to avoid wrong edge detections at the transition.*

## Bit 3 Reserved, always read as 0.

Bits 2:0 **SMS**: Slave mode selection

When external signals are selected the active edge of the trigger signal (TRGI) is linked to the polarity selected on the external input (see Input Control register and Control Register description).

000: Slave mode disabled - if CEN = '1' then the prescaler is clocked directly by the internal clock.

001: Encoder mode 1 - Counter counts up/down on TI2FP2 edge depending on TI1FP1 level.

010: Encoder mode 2 - Counter counts up/down on TI1FP1 edge depending on TI2FP2 level.

011: Encoder mode 3 - Counter counts up/down on both TI1FP1 and TI2FP2 edges depending on the level of the other input.

100: Reset Mode - Rising edge of the selected trigger input (TRGI) reinitializes the counter and generates an update of the registers.

101: Gated Mode - The counter clock is enabled when the trigger input (TRGI) is high. The counter stops (but is not reset) as soon as the trigger becomes low. Both start and stop of the counter are controlled.

110: Trigger Mode - The counter starts at a rising edge of the trigger TRGI (but it is not reset). Only the start of the counter is controlled.

111: External Clock Mode 1 - Rising edges of the selected trigger (TRGI) clock the counter.

*Note: The gated mode must not be used if TI1F\_ED is selected as the trigger input (TS='100'). Indeed, TI1F\_ED outputs 1 pulse for each transition on TI1F, whereas the gated mode checks the level of the trigger signal.*

**Table 80. TIMx Internal trigger connection<sup>(1)</sup>**

Slave TIM	ITR0 (TS = 000)	ITR1 (TS = 001)	ITR2 (TS = 010)	ITR3 (TS = 011)
TIM1	TIM5	TIM2	TIM3	TIM4
TIM8	TIM1	TIM2	TIM4	TIM5

1. When a timer is not present in the product, the corresponding trigger ITRx is not available.

**13.4.4 TIM1&TIM8 DMA/interrupt enable register (TIMx\_DIER)**

Address offset: 0x0C

Reset value: 0x0000

	15	14	13	12	11	10	9	8	7	6	5	4	3	2	1	0
Res.	TDE	COMDE	CC4DE	CC3DE	CC2DE	CC1DE	UDE	BIE	TIE	COMIE	CC4IE	CC3IE	CC2IE	CC1IE	UIE	
	r/w	r/w	r/w	r/w	r/w	r/w	r/w	r/w	r/w	r/w	r/w	r/w	r/w	r/w	r/w	r/w

Bit 15 Reserved, always read as 0.

Bit 14 **TDE**: Trigger DMA request enable

0: Trigger DMA request disabled

1: Trigger DMA request enabled

Bit 13 **COMDE**: COM DMA request enable

0: COM DMA request disabled

1: COM DMA request enabled

- Bit 12 **CC4DE**: Capture/Compare 4 DMA request enable  
0: CC4 DMA request disabled  
1: CC4 DMA request enabled
- Bit 11 **CC3DE**: Capture/Compare 3 DMA request enable  
0: CC3 DMA request disabled  
1: CC3 DMA request enabled
- Bit 10 **CC2DE**: Capture/Compare 2 DMA request enable  
0: CC2 DMA request disabled  
1: CC2 DMA request enabled
- Bit 9 **CC1DE**: Capture/Compare 1 DMA request enable  
0: CC1 DMA request disabled  
1: CC1 DMA request enabled
- Bit 8 **UDE**: Update DMA request enable  
0: Update DMA request disabled  
1: Update DMA request enabled
- Bit 7 **BIE**: Break interrupt enable  
0: Break interrupt disabled  
1: Break interrupt enabled
- Bit 6 **TIE**: Trigger interrupt enable  
0: Trigger interrupt disabled  
1: Trigger interrupt enabled
- Bit 5 **COMIE**: COM interrupt enable  
0: COM interrupt disabled  
1: COM interrupt enabled
- Bit 4 **CC4IE**: Capture/Compare 4 interrupt enable  
0: CC4 interrupt disabled  
1: CC4 interrupt enabled
- Bit 3 **CC3IE**: Capture/Compare 3 interrupt enable  
0: CC3 interrupt disabled  
1: CC3 interrupt enabled
- Bit 2 **CC2IE**: Capture/Compare 2 interrupt enable  
0: CC2 interrupt disabled  
1: CC2 interrupt enabled
- Bit 1 **CC1IE**: Capture/Compare 1 interrupt enable  
0: CC1 interrupt disabled  
1: CC1 interrupt enabled
- Bit 0 **UIE**: Update interrupt enable  
0: Update interrupt disabled  
1: Update interrupt enabled

### 13.4.5 TIM1&TIM8 status register (TIMx\_SR)

Address offset: 0x10

Reset value: 0x0000

15	14	13	12	11	10	9	8	7	6	5	4	3	2	1	0
Reserved		CC4OF	CC3OF	CC2OF	CC1OF	Res.	BIF	TIF	COMIF	CC4IF	CC3IF	CC2IF	CC1IF	UIF	
		rc_w0	rc_w0	rc_w0	rc_w0	Res.	rc_w0	rc_w0	rc_w0	rc_w0	rc_w0	rc_w0	rc_w0	rc_w0	rc_w0

Bits 15:13 Reserved, always read as 0.

Bit 12 **CC4OF**: Capture/Compare 4 overcapture flag  
refer to CC1OF description

Bit 11 **CC3OF**: Capture/Compare 3 overcapture flag  
refer to CC1OF description

Bit 10 **CC2OF**: Capture/Compare 2 overcapture flag  
refer to CC1OF description

Bit 9 **CC1OF**: Capture/Compare 1 overcapture flag  
This flag is set by hardware only when the corresponding channel is configured in input capture mode. It is cleared by software by writing it to '0'.  
0: No overcapture has been detected.  
1: The counter value has been captured in TIMx\_CCR1 register while CC1IF flag was already set

Bit 8 Reserved, always read as 0.

Bit 7 **BIF**: Break interrupt flag  
This flag is set by hardware as soon as the break input goes active. It can be cleared by software if the break input is not active.  
0: No break event occurred.  
1: An active level has been detected on the break input.

Bit 6 **TIF**: Trigger interrupt flag  
This flag is set by hardware on trigger event (active edge detected on TRGI input when the slave mode controller is enabled in all modes but gated mode, both edges in case gated mode is selected). It is cleared by software.  
0: No trigger event occurred.  
1: Trigger interrupt pending.

Bit 5 **COMIF**: COM interrupt flag  
This flag is set by hardware on COM event (when Capture/compare Control bits - CCxE, CCxNE, OCxM - have been updated). It is cleared by software.  
0: No COM event occurred.  
1: COM interrupt pending.

Bit 4 **CC4IF**: Capture/Compare 4 interrupt flag  
refer to CC1IF description

Bit 3 **CC3IF**: Capture/Compare 3 interrupt flag  
refer to CC1IF description

Bit 2 **CC2IF**: Capture/Compare 2 interrupt flag  
refer to CC1IF description

Bit 1 **CC1IF**: Capture/Compare 1 interrupt flag

**If channel CC1 is configured as output:**

This flag is set by hardware when the counter matches the compare value, with some exception in center-aligned mode (refer to the CMS bits in the TIMx\_CR1 register description). It is cleared by software.

0: No match.

1: The content of the counter TIMx\_CNT matches the content of the TIMx\_CCR1 register. When the contents of TIMx\_CCR1 are greater than the contents of TIMx\_ARR, the CC1IF bit goes high on the counter overflow (in upcounting and up/down-counting modes) or underflow (in downcounting mode)

**If channel CC1 is configured as input:**

This bit is set by hardware on a capture. It is cleared by software or by reading the TIMx\_CCR1 register.

0: No input capture occurred

1: The counter value has been captured in TIMx\_CCR1 register (An edge has been detected on IC1 which matches the selected polarity)

Bit 0 **UIF**: Update interrupt flag

This bit is set by hardware on an update event. It is cleared by software.

0: No update occurred.

1: Update interrupt pending. This bit is set by hardware when the registers are updated:

–At overflow or underflow regarding the repetition counter value (update if repetition counter = 0) and if the UDIS=0 in the TIMx\_CR1 register.

–When CNT is reinitialized by software using the UG bit in TIMx\_EGR register, if URS=0 and UDIS=0 in the TIMx\_CR1 register.

–When CNT is reinitialized by a trigger event (refer to [Section 13.4.3: TIM1&TIM8 slave mode control register \(TIMx\\_SMCR\)](#)), if URS=0 and UDIS=0 in the TIMx\_CR1 register.

### 13.4.6 TIM1&TIM8 event generation register (TIMx\_EGR)

Address offset: 0x14

Reset value: 0x0000

15	14	13	12	11	10	9	8	7	6	5	4	3	2	1	0
Reserved								BG	TG	COMG	CC4G	CC3G	CC2G	CC1G	UG
								w	w	w	w	w	w	w	w

Bits 15:8 Reserved, always read as 0.

Bit 7 **BG**: Break generation

This bit is set by software in order to generate an event, it is automatically cleared by hardware.

0: No action

1: A break event is generated. MOE bit is cleared and BIF flag is set. Related interrupt or DMA transfer can occur if enabled.

Bit 6 **TG**: Trigger generation

This bit is set by software in order to generate an event, it is automatically cleared by hardware.

0: No action

1: The TIF flag is set in TIMx\_SR register. Related interrupt or DMA transfer can occur if enabled.

Bit 5 **COMG**: Capture/Compare control update generation

This bit can be set by software, it is automatically cleared by hardware

0: No action

1: When CCPC bit is set, it allows to update CCxE, CCxNE and OCxM bits

*Note: This bit acts only on channels having a complementary output.*

Bit 4 **CC4G**: Capture/Compare 4 generation

refer to CC1G description

Bit 3 **CC3G**: Capture/Compare 3 generation

refer to CC1G description

Bit 2 **CC2G**: Capture/Compare 2 generation

refer to CC1G description

Bit 1 **CC1G**: Capture/Compare 1 generation

This bit is set by software in order to generate an event, it is automatically cleared by hardware.

0: No action

1: A capture/compare event is generated on channel 1:

**If channel CC1 is configured as output:**

CC1IF flag is set, Corresponding interrupt or DMA request is sent if enabled.

**If channel CC1 is configured as input:**

The current value of the counter is captured in TIMx\_CCR1 register. The CC1IF flag is set, the corresponding interrupt or DMA request is sent if enabled. The CC1OF flag is set if the CC1IF flag was already high.

Bit 0 **UG**: Update generation

This bit can be set by software, it is automatically cleared by hardware.

0: No action

1: Reinitialize the counter and generates an update of the registers. Note that the prescaler counter is cleared too (anyway the prescaler ratio is not affected). The counter is cleared if the center-aligned mode is selected or if DIR=0 (upcounting), else it takes the auto-reload value (TIMx\_ARR) if DIR=1 (downcounting).

### 13.4.7 TIM1&TIM8 capture/compare mode register 1 (TIMx\_CCMR1)

Address offset: 0x18

Reset value: 0x0000

The channels can be used in input (capture mode) or in output (compare mode). The direction of a channel is defined by configuring the corresponding CCxS bits. All the other bits of this register have a different function in input and in output mode. For a given bit, OCxx describes its function when the channel is configured in output, ICxx describes its function when the channel is configured in input. So you must take care that the same bit can have a different meaning for the input stage and for the output stage.

15	14	13	12	11	10	9	8	7	6	5	4	3	2	1	0
OC2 CE	OC2M[2:0]			OC2 PE	OC2 FE	CC2S[1:0]		OC1 CE	OC1M[2:0]			OC1 PE	OC1 FE	CC1S[1:0]	
IC2F[3:0]				IC2PSC[1:0]				IC1F[3:0]				IC1PSC[1:0]			
rw	rw	rw	rw	rw	rw	rw	rw	rw	rw	rw	rw	rw	rw	rw	rw

#### Output compare mode:

Bit 15 **OC2CE**: Output Compare 2 clear enable

Bits 14:12 **OC2M[2:0]**: Output Compare 2 mode

Bit 11 **OC2PE**: Output Compare 2 preload enable

Bit 10 **OC2FE**: Output Compare 2 fast enable

Bits 9:8 **CC2S[1:0]**: Capture/Compare 2 selection

This bit-field defines the direction of the channel (input/output) as well as the used input.

00: CC2 channel is configured as output

01: CC2 channel is configured as input, IC2 is mapped on TI2

10: CC2 channel is configured as input, IC2 is mapped on TI1

11: CC2 channel is configured as input, IC2 is mapped on TRC. This mode is working only if an internal trigger input is selected through the TS bit (TIMx\_SMCR register)

*Note: CC2S bits are writable only when the channel is OFF (CC2E = '0' in TIMx\_CCER).*

Bit 7 **OC1CE**: Output Compare 1 clear enable

OC1CE: Output Compare 1 Clear Enable

0: OC1Ref is not affected by the ETRF Input

1: OC1Ref is cleared as soon as a High level is detected on ETRF input



Bits 6:4 **OC1M**: Output Compare 1 mode

These bits define the behavior of the output reference signal OC1REF from which OC1 and OC1N are derived. OC1REF is active high whereas OC1 and OC1N active level depends on CC1P and CC1NP bits.

000: Frozen - The comparison between the output compare register TIMx\_CCR1 and the counter TIMx\_CNT has no effect on the outputs.(this mode is used to generate a timing base).

001: Set channel 1 to active level on match. OC1REF signal is forced high when the counter TIMx\_CNT matches the capture/compare register 1 (TIMx\_CCR1).

010: Set channel 1 to inactive level on match. OC1REF signal is forced low when the counter TIMx\_CNT matches the capture/compare register 1 (TIMx\_CCR1).

011: Toggle - OC1REF toggles when TIMx\_CNT=TIMx\_CCR1.

100: Force inactive level - OC1REF is forced low.

101: Force active level - OC1REF is forced high.

110: PWM mode 1 - In upcounting, channel 1 is active as long as TIMx\_CNT<TIMx\_CCR1 else inactive. In downcounting, channel 1 is inactive (OC1REF='0') as long as TIMx\_CNT>TIMx\_CCR1 else active (OC1REF='1').

111: PWM mode 2 - In upcounting, channel 1 is inactive as long as TIMx\_CNT<TIMx\_CCR1 else active. In downcounting, channel 1 is active as long as TIMx\_CNT>TIMx\_CCR1 else inactive.

*Note: 1: These bits can not be modified as long as LOCK level 3 has been programmed (LOCK bits in TIMx\_BDTR register) and CC1S='00' (the channel is configured in output).*

*2: In PWM mode 1 or 2, the OCREF level changes only when the result of the comparison changes or when the output compare mode switches from "frozen" mode to "PWM" mode.*

Bit 3 **OC1PE**: Output Compare 1 preload enable

0: Preload register on TIMx\_CCR1 disabled. TIMx\_CCR1 can be written at anytime, the new value is taken in account immediately.

1: Preload register on TIMx\_CCR1 enabled. Read/Write operations access the preload register. TIMx\_CCR1 preload value is loaded in the active register at each update event.

*Note: 1: These bits can not be modified as long as LOCK level 3 has been programmed (LOCK bits in TIMx\_BDTR register) and CC1S='00' (the channel is configured in output).*

*2: The PWM mode can be used without validating the preload register only in one pulse mode (OPM bit set in TIMx\_CR1 register). Else the behavior is not guaranteed.*

Bit 2 **OC1FE**: Output Compare 1 fast enable

This bit is used to accelerate the effect of an event on the trigger in input on the CC output.  
0: CC1 behaves normally depending on counter and CCR1 values even when the trigger is ON. The minimum delay to activate CC1 output when an edge occurs on the trigger input is 5 clock cycles.

1: An active edge on the trigger input acts like a compare match on CC1 output. Then, OC is set to the compare level independently from the result of the comparison. Delay to sample the trigger input and to activate CC1 output is reduced to 3 clock cycles. OC1FE acts only if the channel is configured in PWM1 or PWM2 mode.

Bits 1:0 **CC1S**: Capture/Compare 1 selection

This bit-field defines the direction of the channel (input/output) as well as the used input.

00: CC1 channel is configured as output

01: CC1 channel is configured as input, IC1 is mapped on TI1

10: CC1 channel is configured as input, IC1 is mapped on TI2

11: CC1 channel is configured as input, IC1 is mapped on TRC. This mode is working only if an internal trigger input is selected through TS bit (TIMx\_SMCR register)

*Note: CC1S bits are writable only when the channel is OFF (CC1E = '0' in TIMx\_CCER).*

## Input capture mode

Bits 15:12 **IC2F**: Input capture 2 filter

Bits 11:10 **IC2PSC[1:0]**: Input capture 2 prescaler

Bits 9:8 **CC2S**: Capture/Compare 2 selection

This bit-field defines the direction of the channel (input/output) as well as the used input.

00: CC2 channel is configured as output

01: CC2 channel is configured as input, IC2 is mapped on TI2

10: CC2 channel is configured as input, IC2 is mapped on TI1

11: CC2 channel is configured as input, IC2 is mapped on TRC. This mode is working only if an internal trigger input is selected through TS bit (TIMx\_SMCR register)

*Note: CC2S bits are writable only when the channel is OFF (CC2E = '0' in TIMx\_CCER).*

Bits 7:4 **IC1F[3:0]**: Input capture 1 filter

This bit-field defines the frequency used to sample TI1 input and the length of the digital filter applied to TI1. The digital filter is made of an event counter in which N events are needed to validate a transition on the output:

0000: No filter, sampling is done at  $f_{DTS}$

0001:  $f_{SAMPLING}=f_{CK\_INT}$ , N=2

0010:  $f_{SAMPLING}=f_{CK\_INT}$ , N=4

0011:  $f_{SAMPLING}=f_{CK\_INT}$ , N=8

0100:  $f_{SAMPLING}=f_{DTS}/2$ , N=6

0101:  $f_{SAMPLING}=f_{DTS}/2$ , N=8

0110:  $f_{SAMPLING}=f_{DTS}/4$ , N=6

0111:  $f_{SAMPLING}=f_{DTS}/4$ , N=8

1000:  $f_{SAMPLING}=f_{DTS}/8$ , N=6

1001:  $f_{SAMPLING}=f_{DTS}/8$ , N=8

1010:  $f_{SAMPLING}=f_{DTS}/16$ , N=5

1011:  $f_{SAMPLING}=f_{DTS}/16$ , N=6

1100:  $f_{SAMPLING}=f_{DTS}/16$ , N=8

1101:  $f_{SAMPLING}=f_{DTS}/32$ , N=5

1110:  $f_{SAMPLING}=f_{DTS}/32$ , N=6

1111:  $f_{SAMPLING}=f_{DTS}/32$ , N=8

Bits 3:2 **IC1PSC**: Input capture 1 prescaler

This bit-field defines the ratio of the prescaler acting on CC1 input (IC1).

The prescaler is reset as soon as CC1E='0' (TIMx\_CCER register).

00: no prescaler, capture is done each time an edge is detected on the capture input

01: capture is done once every 2 events

10: capture is done once every 4 events

11: capture is done once every 8 events

Bits 1:0 **CC1S**: Capture/Compare 1 Selection

This bit-field defines the direction of the channel (input/output) as well as the used input.

00: CC1 channel is configured as output

01: CC1 channel is configured as input, IC1 is mapped on TI1

10: CC1 channel is configured as input, IC1 is mapped on TI2

11: CC1 channel is configured as input, IC1 is mapped on TRC. This mode is working only if an internal trigger input is selected through TS bit (TIMx\_SMCR register)

*Note: CC1S bits are writable only when the channel is OFF (CC1E = '0' in TIMx\_CCER).*

### 13.4.8 TIM1&TIM8 capture/compare mode register 2 (TIMx\_CCMR2)

Address offset: 0x1C

Reset value: 0x0000

Refer to the above CCMR1 register description.

15	14	13	12	11	10	9	8	7	6	5	4	3	2	1	0
OC4 CE	OC4M[2:0]			OC4 PE	OC4 FE	CC4S[1:0]		OC3 CE.	OC3M[2:0]			OC3 PE	OC3 FE	CC3S[1:0]	
IC4F[3:0]				IC4PSC[1:0]				IC3F[3:0]				IC3PSC[1:0]			
rw	rw	rw	rw	rw	rw	rw	rw	rw	rw	rw	rw	rw	rw	rw	rw

#### Output compare mode

Bit 15 **OC4CE**: Output compare 4 clear enable

Bits 14:12 **OC4M**: Output compare 4 mode

Bit 11 **OC4PE**: Output compare 4 preload enable

Bit 10 **OC4FE**: Output compare 4 fast enable

Bits 9:8 **CC4S**: Capture/Compare 4 selection

This bit-field defines the direction of the channel (input/output) as well as the used input.

00: CC4 channel is configured as output

01: CC4 channel is configured as input, IC4 is mapped on TI4

10: CC4 channel is configured as input, IC4 is mapped on TI3

11: CC4 channel is configured as input, IC4 is mapped on TRC. This mode is working only if an internal trigger input is selected through TS bit (TIMx\_SMCR register)

*Note: CC4S bits are writable only when the channel is OFF (CC4E = '0' in TIMx\_CCER).*

Bit 7 **OC3CE**: Output compare 3 clear enable

Bits 6:4 **OC3M**: Output compare 3 mode

Bit 3 **OC3PE**: Output compare 3 preload enable

Bit 2 **OC3FE**: Output compare 3 fast enable

Bits 1:0 **CC3S**: Capture/Compare 3 selection

This bit-field defines the direction of the channel (input/output) as well as the used input.

00: CC3 channel is configured as output

01: CC3 channel is configured as input, IC3 is mapped on TI3

10: CC3 channel is configured as input, IC3 is mapped on TI4

11: CC3 channel is configured as input, IC3 is mapped on TRC. This mode is working only if an internal trigger input is selected through TS bit (TIMx\_SMCR register)

*Note: CC3S bits are writable only when the channel is OFF (CC3E = '0' in TIMx\_CCER).*

### Input capture mode

Bits 15:12 **IC4F**: Input capture 4 filter

Bits 11:10 **IC4PSC**: Input capture 4 prescaler

Bits 9:8 **CC4S**: Capture/Compare 4 selection

This bit-field defines the direction of the channel (input/output) as well as the used input.

00: CC4 channel is configured as output

01: CC4 channel is configured as input, IC4 is mapped on TI4

10: CC4 channel is configured as input, IC4 is mapped on TI3

11: CC4 channel is configured as input, IC4 is mapped on TRC. This mode is working only if an internal trigger input is selected through TS bit (TIMx\_SMCR register)

*Note: CC4S bits are writable only when the channel is OFF (CC4E = '0' in TIMx\_CCER).*

Bits 7:4 **IC3F**: Input capture 3 filter

Bits 3:2 **IC3PSC**: Input capture 3 prescaler

Bits 1:0 **CC3S**: Capture/compare 3 selection

This bit-field defines the direction of the channel (input/output) as well as the used input.

00: CC3 channel is configured as output

01: CC3 channel is configured as input, IC3 is mapped on TI3

10: CC3 channel is configured as input, IC3 is mapped on TI4

11: CC3 channel is configured as input, IC3 is mapped on TRC. This mode is working only if an internal trigger input is selected through TS bit (TIMx\_SMCR register)

*Note: CC3S bits are writable only when the channel is OFF (CC3E = '0' in TIMx\_CCER).*

### 13.4.9 TIM1&TIM8 capture/compare enable register (TIMx\_CCER)

Address offset: 0x20

Reset value: 0x0000

15	14	13	12	11	10	9	8	7	6	5	4	3	2	1	0
Reserved		CC4P	CC4E	CC3NP	CC3NE	CC3P	CC3E	CC2NP	CC2NE	CC2P	CC2E	CC1NP	CC1NE	CC1P	CC1E
		rw	rw	rw	rw	rw	rw	rw	rw	rw	rw	rw	rw	rw	rw

Bits 15:14 Reserved, always read as 0.

Bit 13 **CC4P**: Capture/Compare 4 output polarity  
refer to CC1P description

Bit 12 **CC4E**: Capture/Compare 4 output enable  
refer to CC1E description

Bit 11 **CC3NP**: Capture/Compare 3 complementary output polarity  
refer to CC1NP description

Bit 10 **CC3NE**: Capture/Compare 3 complementary output enable  
refer to CC1NE description

Bit 9 **CC3P**: Capture/Compare 3 output polarity  
refer to CC1P description

Bit 8 **CC3E**: Capture/Compare 3 output enable  
refer to CC1E description

Bit 7 **CC2NP**: Capture/Compare 2 complementary output polarity  
refer to CC1NP description

Bit 6 **CC2NE**: Capture/Compare 2 complementary output enable  
refer to CC1NE description

Bit 5 **CC2P**: Capture/Compare 2 output polarity  
refer to CC1P description

Bit 4 **CC2E**: Capture/Compare 2 output enable  
refer to CC1E description

Bit 3 **CC1NP**: Capture/Compare 1 complementary output polarity  
0: OC1N active high.  
1: OC1N active low.

*Note: This bit is not writable as soon as LOCK level 2 or 3 has been programmed (LOCK bits in TIMx\_BDTR register) and CC1S="00" (the channel is configured in output).*

Bit 2 **CC1NE**: Capture/Compare 1 complementary output enable  
0: Off - OC1N is not active. OC1N level is then function of MOE, OSSI, OSSR, OIS1, OIS1N and CC1E bits.  
1: On - OC1N signal is output on the corresponding output pin depending on MOE, OSSI, OSSR, OIS1, OIS1N and CC1E bits.

Bit 1 **CC1P**: Capture/Compare 1 output polarity

**CC1 channel configured as output:**

0: OC1 active high

1: OC1 active low

**CC1 channel configured as input:**

This bit selects whether IC1 or IC1 is used for trigger or capture operations.

0: non-inverted: capture is done on a rising edge of IC1. When used as external trigger, IC1 is non-inverted.

1: inverted: capture is done on a falling edge of IC1. When used as external trigger, IC1 is inverted.

*Note: This bit is not writable as soon as LOCK level 2 or 3 has been programmed (LOCK bits in TIMx\_BDTR register).*

Bit 0 **CC1E**: Capture/Compare 1 output enable

**CC1 channel configured as output:**

0: Off - OC1 is not active. OC1 level is then function of MOE, OSSI, OSSR, OIS1, OIS1N and CC1NE bits.

1: On - OC1 signal is output on the corresponding output pin depending on MOE, OSSI, OSSR, OIS1, OIS1N and CC1NE bits.

**CC1 channel configured as input:**

This bit determines if a capture of the counter value can actually be done into the input capture/compare register 1 (TIMx\_CCR1) or not.

0: Capture disabled.

1: Capture enabled.

**Table 81. Output control bits for complementary OCx and OCxN channels with break feature**

Control bits					Output states <sup>(1)</sup>	
MOE bit	OSSI bit	OSSR bit	CCxE bit	CCxNE bit	OCx output state	OCxN output state
1	X	0	0	0	Output Disabled (not driven by the timer) OCx=0, OCx_EN=0	Output Disabled (not driven by the timer) OCxN=0, OCxN_EN=0
		0	0	1	Output Disabled (not driven by the timer) OCx=0, OCx_EN=0	OCxREF + Polarity OCxN=OCxREF xor CCxNP, OCxN_EN=1
		0	1	0	OCxREF + Polarity OCx=OCxREF xor CCxP, OCx_EN=1	Output Disabled (not driven by the timer) OCxN=0, OCxN_EN=0
		0	1	1	OCREF + Polarity + dead-time OCx_EN=1	Complementary to OCREF (not OCREF) + Polarity + dead-time OCxN_EN=1
		1	0	0	Output Disabled (not driven by the timer) OCx=CCxP, OCx_EN=0	Output Disabled (not driven by the timer) OCxN=CCxNP, OCxN_EN=0
		1	0	1	Off-State (output enabled with inactive state) OCx=CCxP, OCx_EN=1	OCxREF + Polarity OCxN=OCxREF xor CCxNP, OCxN_EN=1
		1	1	0	OCxREF + Polarity OCx=OCxREF xor CCxP, OCx_EN=1	Off-State (output enabled with inactive state) OCxN=CCxNP, OCxN_EN=1
		1	1	1	OCREF + Polarity + dead-time OCx_EN=1	Complementary to OCREF (not OCREF) + Polarity + dead-time OCxN_EN=1
0	X	0	0	0	Output Disabled (not driven by the timer) Asynchronously: OCx=CCxP, OCx_EN=0, OCxN=CCxNP, OCxN_EN=0 Then if the clock is present: OCx=OISx and OCxN=OISxN after a dead-time, assuming that OISx and OISxN do not correspond to OCX and OCxN both in active state.	
		0	0	1		
		0	1	0		
		0	1	1		
		1	0	0	Off-State (output enabled with inactive state) Asynchronously: OCx=CCxP, OCx_EN=1, OCxN=CCxNP, OCxN_EN=1 Then if the clock is present: OCx=OISx and OCxN=OISxN after a dead-time, assuming that OISx and OISxN do not correspond to OCX and OCxN both in active state	
		1	0	1		
		1	1	0		
		1	1	1		

1. When both outputs of a channel are not used (CCxE = CCxNE = 0), the OISx, OISxN, CCxP and CCxNP bits must be kept cleared.

*Note: The state of the external I/O pins connected to the complementary OCx and OCxN channels depends on the OCx and OCxN channel state and the GPIO and AFIO registers.*

### 13.4.10 TIM1&TIM8 counter (TIMx\_CNT)

Address offset: 0x24

Reset value: 0x0000

15	14	13	12	11	10	9	8	7	6	5	4	3	2	1	0
CNT[15:0]															
rw	rw	rw	rw	rw	rw	rw	rw	rw	rw	rw	rw	rw	rw	rw	rw

Bits 15:0 **CNT[15:0]**: Counter value

### 13.4.11 TIM1&TIM8 prescaler (TIMx\_PSC)

Address offset: 0x28

Reset value: 0x0000

15	14	13	12	11	10	9	8	7	6	5	4	3	2	1	0
PSC[15:0]															
rw	rw	rw	rw	rw	rw	rw	rw	rw	rw	rw	rw	rw	rw	rw	rw

Bits 15:0 **PSC[15:0]**: Prescaler value

The counter clock frequency (CK\_CNT) is equal to  $f_{CK\_PSC} / (PSC[15:0] + 1)$ .

PSC contains the value to be loaded in the active prescaler register at each update event (including when the counter is cleared through UG bit of TIMx\_EGR register or through trigger controller when configured in “reset mode”).

### 13.4.12 TIM1&TIM8 auto-reload register (TIMx\_ARR)

Address offset: 0x2C

Reset value: 0x0000

15	14	13	12	11	10	9	8	7	6	5	4	3	2	1	0
ARR[15:0]															
rw	rw	rw	rw	rw	rw	rw	rw	rw	rw	rw	rw	rw	rw	rw	rw

Bits 15:0 **ARR[15:0]**: Prescaler value

ARR is the value to be loaded in the actual auto-reload register.

Refer to the [Section 13.3.1: Time-base unit on page 272](#) for more details about ARR update and behavior.

The counter is blocked while the auto-reload value is null.

### 13.4.13 TIM1&TIM8 repetition counter register (TIMx\_RCR)

Address offset: 0x30

Reset value: 0x0000

15	14	13	12	11	10	9	8	7	6	5	4	3	2	1	0	
Reserved								REP[7:0]								
								rw	rw	rw	rw	rw	rw	rw	rw	rw

Bits 15:8 Reserved, always read as 0.

Bits 7:0 **REP[7:0]**: Repetition counter value

These bits allow the user to set-up the update rate of the compare registers (i.e. periodic transfers from preload to active registers) when preload registers are enable, as well as the update interrupt generation rate, if this interrupt is enable.

Each time the REP\_CNT related downcounter reaches zero, an update event is generated and it restarts counting from REP value. As REP\_CNT is reloaded with REP value only at the repetition update event U\_RC, any write to the TIMx\_RCR register is not taken in account until the next repetition update event.

It means in PWM mode (REP+1) corresponds to:

- the number of PWM periods in edge-aligned mode
- the number of half PWM period in center-aligned mode.

### 13.4.14 TIM1&TIM8 capture/compare register 1 (TIMx\_CCR1)

Address offset: 0x34

Reset value: 0x0000

15	14	13	12	11	10	9	8	7	6	5	4	3	2	1	0
CCR1[15:0]															
rw	rw	rw	rw	rw	rw	rw	rw	rw	rw	rw	rw	rw	rw	rw	rw

Bits 15:0 **CCR1[15:0]**: Capture/Compare 1 value

**If channel CC1 is configured as output:**

CCR1 is the value to be loaded in the actual capture/compare 1 register (preload value).

It is loaded permanently if the preload feature is not selected in the TIMx\_CCMR1 register (bit OC1PE). Else the preload value is copied in the active capture/compare 1 register when an update event occurs.

The active capture/compare register contains the value to be compared to the counter TIMx\_CNT and signaled on OC1 output.

**If channel CC1 is configured as input:**

CCR1 is the counter value transferred by the last input capture 1 event (IC1).



### 13.4.15 TIM1&TIM8 capture/compare register 2 (TIMx\_CCR2)

Address offset: 0x38

Reset value: 0x0000

15	14	13	12	11	10	9	8	7	6	5	4	3	2	1	0
CCR2[15:0]															
rw	rw	rw	rw	rw	rw	rw	rw	rw	rw	rw	rw	rw	rw	rw	rw

Bits 15:0 **CCR2[15:0]**: Capture/Compare 2 value

**If channel CC2 is configured as output:**

CCR2 is the value to be loaded in the actual capture/compare 2 register (preload value).

It is loaded permanently if the preload feature is not selected in the TIMx\_CCMR2 register (bit OC2PE). Else the preload value is copied in the active capture/compare 2 register when an update event occurs.

The active capture/compare register contains the value to be compared to the counter TIMx\_CNT and signalled on OC2 output.

**If channel CC2 is configured as input:**

CCR2 is the counter value transferred by the last input capture 2 event (IC2).

### 13.4.16 TIM1&TIM8 capture/compare register 3 (TIMx\_CCR3)

Address offset: 0x3C

Reset value: 0x0000

15	14	13	12	11	10	9	8	7	6	5	4	3	2	1	0
CCR3[15:0]															
rw	rw	rw	rw	rw	rw	rw	rw	rw	rw	rw	rw	rw	rw	rw	rw

Bits 15:0 **CCR3[15:0]**: Capture/Compare value

**If channel CC3 is configured as output:**

CCR3 is the value to be loaded in the actual capture/compare 3 register (preload value).

It is loaded permanently if the preload feature is not selected in the TIMx\_CCMR3 register (bit OC3PE). Else the preload value is copied in the active capture/compare 3 register when an update event occurs.

The active capture/compare register contains the value to be compared to the counter TIMx\_CNT and signalled on OC3 output.

**If channel CC3 is configured as input:**

CCR3 is the counter value transferred by the last input capture 3 event (IC3).

### 13.4.17 TIM1&TIM8 capture/compare register 4 (TIMx\_CCR4)

Address offset: 0x40

Reset value: 0x0000

15	14	13	12	11	10	9	8	7	6	5	4	3	2	1	0
CCR4[15:0]															
rw	rw	rw	rw	rw	rw	rw	rw	rw	rw	rw	rw	rw	rw	rw	rw

Bits 15:0 **CCR4[15:0]**: Capture/Compare value

**If channel CC4 is configured as output:**

CCR4 is the value to be loaded in the actual capture/compare 4 register (preload value).

It is loaded permanently if the preload feature is not selected in the TIMx\_CCMR4 register (bit OC4PE). Else the preload value is copied in the active capture/compare 4 register when an update event occurs.

The active capture/compare register contains the value to be compared to the counter TIMx\_CNT and signalled on OC4 output.

**If channel CC4 is configured as input:**

CCR4 is the counter value transferred by the last input capture 4 event (IC4).

### 13.4.18 TIM1&TIM8 break and dead-time register (TIMx\_BDTR)

Address offset: 0x44

Reset value: 0x0000

15	14	13	12	11	10	9	8	7	6	5	4	3	2	1	0
MOE	AOE	BKP	BKE	OSSR	OSSI	LOCK[1:0]		DTG[7:0]							
rw	rw	rw	rw	rw	rw	rw	rw	rw	rw	rw	rw	rw	rw	rw	rw

*Note: As the bits AOE, BKP, BKE, OSSI, OSSR and DTG[7:0] can be write-locked depending on the LOCK configuration, it can be necessary to configure all of them during the first write access to the TIMx\_BDTR register.*

Bit 15 **MOE**: Main output enable

This bit is cleared asynchronously by hardware as soon as the break input is active. It is set by software or automatically depending on the AOE bit. It is acting only on the channels which are configured in output.

0: OC and OCN outputs are disabled or forced to idle state.

1: OC and OCN outputs are enabled if their respective enable bits are set (CCxE, CCxNE in TIMx\_CCER register).

See OC/OCN enable description for more details ([Section 13.4.9: TIM1&TIM8 capture/compare enable register \(TIMx\\_CCER\) on page 324](#)).

Bit 14 **AOE**: Automatic output enable

0: MOE can be set only by software

1: MOE can be set by software or automatically at the next update event (if the break input is not be active)

*Note: This bit can not be modified as long as LOCK level 1 has been programmed (LOCK bits in TIMx\_BDTR register).*

Bit 13 **BKP**: Break polarity

- 0: Break input BRK is active low
- 1: Break input BRK is active high

*Note: This bit can not be modified as long as LOCK level 1 has been programmed (LOCK bits in TIMx\_BDTR register).*

*Note: Any write operation to this bit takes a delay of 1 APB clock cycle to become effective.*

Bit 12 **BKE**: Break enable

- 0: Break inputs (BRK and CCS clock failure event) disabled
- 1: Break inputs (BRK and CCS clock failure event) enabled

*Note: This bit cannot be modified when LOCK level 1 has been programmed (LOCK bits in TIMx\_BDTR register).*

*Note: Any write operation to this bit takes a delay of 1 APB clock cycle to become effective.*

Bit 11 **OSSR**: Off-state selection for Run mode

This bit is used when MOE=1 on channels having a complementary output which are configured as outputs. OSSR is not implemented if no complementary output is implemented in the timer.

See OC/OCN enable description for more details ([Section 13.4.9: TIM1&TIM8 capture/compare enable register \(TIMx\\_CCER\) on page 324](#)).

- 0: When inactive, OC/OCN outputs are disabled (OC/OCN enable output signal=0).
- 1: When inactive, OC/OCN outputs are enabled with their inactive level as soon as CCxE=1 or CCxNE=1. Then, OC/OCN enable output signal=1

*Note: This bit can not be modified as soon as the LOCK level 2 has been programmed (LOCK bits in TIMx\_BDTR register).*

Bit 10 **OSSI**: Off-state selection for Idle mode

This bit is used when MOE=0 on channels configured as outputs.

See OC/OCN enable description for more details ([Section 13.4.9: TIM1&TIM8 capture/compare enable register \(TIMx\\_CCER\) on page 324](#)).

- 0: When inactive, OC/OCN outputs are disabled (OC/OCN enable output signal=0).
- 1: When inactive, OC/OCN outputs are forced first with their idle level as soon as CCxE=1 or CCxNE=1. OC/OCN enable output signal=1

*Note: This bit can not be modified as soon as the LOCK level 2 has been programmed (LOCK bits in TIMx\_BDTR register).*

Bits 9:8 **LOCK[1:0]**: Lock configuration

These bits offer a write protection against software errors.

00: LOCK OFF - No bit is write protected.

01: LOCK Level 1 = DTG bits in TIMx\_BDTR register, OISx and OISxN bits in TIMx\_CR2 register and BKE/BKP/AOE bits in TIMx\_BDTR register can no longer be written.

10: LOCK Level 2 = LOCK Level 1 + CC Polarity bits (CCxP/CCxNP bits in TIMx\_CCER register, as long as the related channel is configured in output through the CCxS bits) as well as OSSR and OSSI bits can no longer be written.

11: LOCK Level 3 = LOCK Level 2 + CC Control bits (OCxM and OCxPE bits in TIMx\_CCMRx registers, as long as the related channel is configured in output through the CCxS bits) can no longer be written.

*Note: The LOCK bits can be written only once after the reset. Once the TIMx\_BDTR register has been written, their content is frozen until the next reset.*

Bits 7:0 **DTG[7:0]**: Dead-time generator setup

This bit-field defines the duration of the dead-time inserted between the complementary outputs. DT correspond to this duration.

DTG[7:5]=0xx => DT=DTG[7:0]x  $t_{dtg}$  with  $t_{dtg}=t_{DTS}$ .

DTG[7:5]=10x => DT=(64+DTG[5:0])x $t_{dtg}$  with  $T_{dtg}=2xt_{DTS}$ .

DTG[7:5]=110 => DT=(32+DTG[4:0])x $t_{dtg}$  with  $T_{dtg}=8xt_{DTS}$ .

DTG[7:5]=111 => DT=(32+DTG[4:0])x $t_{dtg}$  with  $T_{dtg}=16xt_{DTS}$ .

Example if  $T_{DTS}=125ns$  (8MHz), dead-time possible values are:

0 to 15875 ns by 125 ns steps,

16 us to 31750 ns by 250 ns steps,

32 us to 63us by 1 us steps,

64 us to 126 us by 2 us steps

*Note: This bit-field can not be modified as long as LOCK level 1, 2 or 3 has been programmed (LOCK bits in TIMx\_BDTR register).*

### 13.4.19 TIM1&TIM8 DMA control register (TIMx\_DCR)

Address offset: 0x48

Reset value: 0x0000

15	14	13	12	11	10	9	8	7	6	5	4	3	2	1	0
Reserved			DBL[4:0]					Reserved			DBA[4:0]				
			rw	rw	rw	rw	rw				rw	rw	rw	rw	rw

Bits 15:13 Reserved, always read as 0

Bits 12:8 **DBL[4:0]**: DMA burst length

This 5-bit vector defines the length of DMA transfers (the timer recognizes a burst transfer when a read or a write access is done to the TIMx\_DMAR address), i.e. the number of transfers. Transfers can be in half-words or in bytes (see example below).

00000: 1 transfer

00001: 2 transfers

00010: 3 transfers

...

10001: 18 transfers

**Example:** Let us consider the following transfer: DBL = 7 bytes & DBA = TIM2\_CR1.

– If DBL = 7 bytes and DBA = TIM2\_CR1 represents the address of the byte to be transferred, the address of the transfer should be given by the following equation:

(TIMx\_CR1 address) + DBA + (DMA index), where DMA index = DBL

In this example, 7 bytes are added to (TIMx\_CR1 address) + DBA, which gives us the address from/to which the data will be copied. In this case, the transfer is done to 7 registers starting from the following address: (TIMx\_CR1 address) + DBA

According to the configuration of the DMA Data Size, several cases may occur:

– If you configure the DMA Data Size in half-words, 16-bit data will be transferred to each of the 7 registers.

– If you configure the DMA Data Size in bytes, the data will also be transferred to 7 registers: the first register will contain the first MSB byte, the second register, the first LSB byte and so on. So with the transfer Timer, you also have to specify the size of data transferred by DMA.

Bits 7:5 Reserved, always read as 0

Bits 4:0 **DBA[4:0]**: DMA base address

This 5-bits vector defines the base-address for DMA transfers (when read/write access are done through the TIMx\_DMAR address). DBA is defined as an offset starting from the address of the TIMx\_CR1 register.

Example:

- 00000: TIMx\_CR1,
- 00001: TIMx\_CR2,
- 00010: TIMx\_SMCR,
- ...

### 13.4.20 TIM1&TIM8 DMA address for full transfer (TIMx\_DMAR)

Address offset: 0x4C

Reset value: 0x0000

	15	14	13	12	11	10	9	8	7	6	5	4	3	2	1	0
	DMAB[15:0]															
	rw	rw	rw	rw	rw	rw	rw	rw	rw	rw	rw	rw	rw	rw	rw	rw

Bits 15:0 **DMAB[15:0]**: DMA register for burst accesses

A read or write access to the DMAR register accesses the register located at the address: “(TIMx\_CR1 address) + DBA + (DMA index)” in which:

TIMx\_CR1 address is the address of the control register 1, DBA is the DMA base address configured in TIMx\_DCR register, DMA index is the offset automatically controlled by the DMA transfer, depending on the length of the transfer DBL in the TIMx\_DCR register.

### 13.4.21 TIM1&TIM8 register map

TIM1&TIM8 registers are mapped as 16-bit addressable registers as described in the table below:

**Table 82. TIM1&TIM8 register map and reset values**

Offset	Register	31	30	29	28	27	26	25	24	23	22	21	20	19	18	17	16	15	14	13	12	11	10	9	8	7	6	5	4	3	2	1	0												
0x00	TIMx_CR1	Reserved																							CKD [1:0]	ARPE	CMS [1:0]	DIR	OPM	URS	UDIS	CEN													
	Reset value	0																							0	0	0	0	0	0	0	0													
0x04	TIMx_CR2	Reserved													OIS4	OIS3N	OIS3	OIS2N	OIS2	OIS1N	OIS1	TI1S	MMS[2:0]	CCDS	CCUS	Reserved	CCPC																		
	Reset value	0													0	0	0	0	0	0	0	0	0	0	0	0	0	0	0	0	0	0	0	0	0	0	0	0	0	0	0				
0x08	TIMx_SMCR	Reserved													ETP	ECE	ETPS [1:0]	ETF[3:0]			MSM	TS[2:0]	Reserved	SMS[2:0]																					
	Reset value	0													0	0	0	0	0	0	0	0	0	0	0	0	0	0	0	0	0	0	0	0	0	0	0	0	0	0	0	0	0	0	0
0x0C	TIMx_DIER	Reserved													TDE	COMDE	CC4DE	CC3DE	CC2DE	CC1DE	UDE	BIE	TIE	COMIE	CC4IE	CC3IE	CC2IE	CC1IE	UIE																
	Reset value	0													0	0	0	0	0	0	0	0	0	0	0	0	0	0	0	0	0	0	0	0	0	0	0	0	0	0	0	0	0	0	0
0x10	TIMx_SR	Reserved													CC4OF	CC3OF	CC2OF	CC1OF	Reserved	BIF	TIF	COMIF	CC4IF	CC3IF	CC2IF	CC1IF	UIF																		
	Reset value	0													0	0	0	0	0	0	0	0	0	0	0	0	0	0	0	0	0	0	0	0	0	0	0	0	0	0	0	0	0	0	0
0x14	TIMx_EGR	Reserved																							BG	TG	COM	CC4G	CC3G	CC2G	CC1G	UG													
	Reset value	0																							0	0	0	0	0	0	0	0													

Table 82. TIM1&TIM8 register map and reset values (continued)

Offset	Register	31	30	29	28	27	26	25	24	23	22	21	20	19	18	17	16	15	14	13	12	11	10	9	8	7	6	5	4	3	2	1	0					
0x18	TIMx_CCMR1 Output Compare mode	Reserved														OC2OE	OC2M [2:0]		OC2PE	OC2FE	CC2S [1:0]		OC1CE	OC1M [2:0]		OC1PE	OC1FE	CC1S [1:0]										
	Reset value	0														0	0	0	0	0	0	0	0	0	0	0	0	0	0	0	0	0	0					
0x18	TIMx_CCMR1 Input Capture mode	Reserved														IC2F[3:0]			IC2PSC [1:0]	CC2S [1:0]		IC1F[3:0]			IC1PSC [1:0]	CC1S [1:0]												
	Reset value	0														0	0	0	0	0	0	0	0	0	0	0	0	0	0	0	0							
0x1C	TIMx_CCMR2 Output Compare mode	Reserved														OC4OE	OC4M [2:0]		OC4PE	OC4FE	CC4S [1:0]		OC3CE	OC3M [2:0]		OC3PE	OC3FE	CC3S [1:0]										
	Reset value	0														0	0	0	0	0	0	0	0	0	0	0	0	0	0	0	0							
0x1C	TIMx_CCMR2 Input Capture mode	Reserved														IC4F[3:0]			IC4PSC [1:0]	CC4S [1:0]		IC3F[3:0]			IC3PSC [1:0]	CC3S [1:0]												
	Reset value	0														0	0	0	0	0	0	0	0	0	0	0	0	0	0	0	0							
0x20	TIMx_CCER	Reserved														CC4P	CC4E	CC3NP	CC3NE	CC3P	CC3E	CC2NP	CC2NE	CC2P	CC2E	CC1NP	CC1NE	CC1P	CC1E									
	Reset value	0														0	0	0	0	0	0	0	0	0	0	0	0	0	0									
0x24	TIMx_CNT	Reserved														CNT[15:0]																						
	Reset value	0														0	0	0	0	0	0	0	0	0	0	0	0	0	0	0	0	0	0	0	0	0		
0x28	TIMx_PSC	Reserved														PSC[15:0]																						
	Reset value	0														0	0	0	0	0	0	0	0	0	0	0	0	0	0	0	0	0	0	0	0	0	0	
0x2C	TIMx_ARR	Reserved														ARR[15:0]																						
	Reset value	0														0	0	0	0	0	0	0	0	0	0	0	0	0	0	0	0	0	0	0	0	0	0	
0x30	TIMx_RCR	Reserved														REP[7:0]																						
	Reset value	0														0	0	0	0	0	0	0	0	0	0	0	0	0	0	0	0							
0x34	TIMx_CCR1	Reserved														CCR1[15:0]																						
	Reset value	0														0	0	0	0	0	0	0	0	0	0	0	0	0	0	0	0	0	0	0	0	0	0	
0x38	TIMx_CCR2	Reserved														CCR2[15:0]																						
	Reset value	0														0	0	0	0	0	0	0	0	0	0	0	0	0	0	0	0	0	0	0	0	0	0	
0x3C	TIMx_CCR3	Reserved														CCR3[15:0]																						
	Reset value	0														0	0	0	0	0	0	0	0	0	0	0	0	0	0	0	0	0	0	0	0	0	0	
0x40	TIMx_CCR4	Reserved														CCR4[15:0]																						
	Reset value	0														0	0	0	0	0	0	0	0	0	0	0	0	0	0	0	0	0	0	0	0	0	0	
0x44	TIMx_BDTR	Reserved														MOE	AOE	BKP	BKE	OSSR	OSSI	LOCK [1:0]	DT[7:0]															
	Reset value	0														0	0	0	0	0	0	0	0	0	0	0	0	0	0	0	0	0	0	0	0	0	0	0
0x48	TIMx_DCR	Reserved														DBL[4:0]				Reserved				DBA[4:0]														
	Reset value	0														0	0	0	0	0	0	0	0	0	0	0	0	0	0	0	0	0	0	0	0	0		
0x4C	TIMx_DMAR	Reserved														DMAB[15:0]																						
	Reset value	0														0	0	0	0	0	0	0	0	0	0	0	0	0	0	0	0	0	0	0	0	0	0	

Refer to [Table 1 on page 44](#) for the register boundary addresses.

## 14 General-purpose timer (TIM2 to TIM5)

**Low-density devices** are STM32F101xx, STM32F102xx and STM32F103xx microcontrollers where the Flash memory density ranges between 16 and 32 Kbytes.

**Medium-density devices** are STM32F101xx, STM32F102xx and STM32F103xx microcontrollers where the Flash memory density ranges between 64 and 128 Kbytes.

**High-density devices** are STM32F101xx and STM32F103xx microcontrollers where the Flash memory density ranges between 256 and 512 Kbytes.

**XL-density devices** are STM32F101xx and STM32F103xx microcontrollers where the Flash memory density ranges between 768 Kbytes and 1 Mbyte.

**Connectivity line devices** are STM32F105xx and STM32F107xx microcontrollers.

This Section applies to the whole STM32F10xxx family, unless otherwise specified.

### 14.1 TIM2 to TIM5 introduction

The general-purpose timers consist of a 16-bit auto-reload counter driven by a programmable prescaler.

They may be used for a variety of purposes, including measuring the pulse lengths of input signals (*input capture*) or generating output waveforms (*output compare and PWM*).

Pulse lengths and waveform periods can be modulated from a few microseconds to several milliseconds using the timer prescaler and the RCC clock controller prescalers.

The timers are completely independent, and do not share any resources. They can be synchronized together as described in [Section 14.3.15](#).

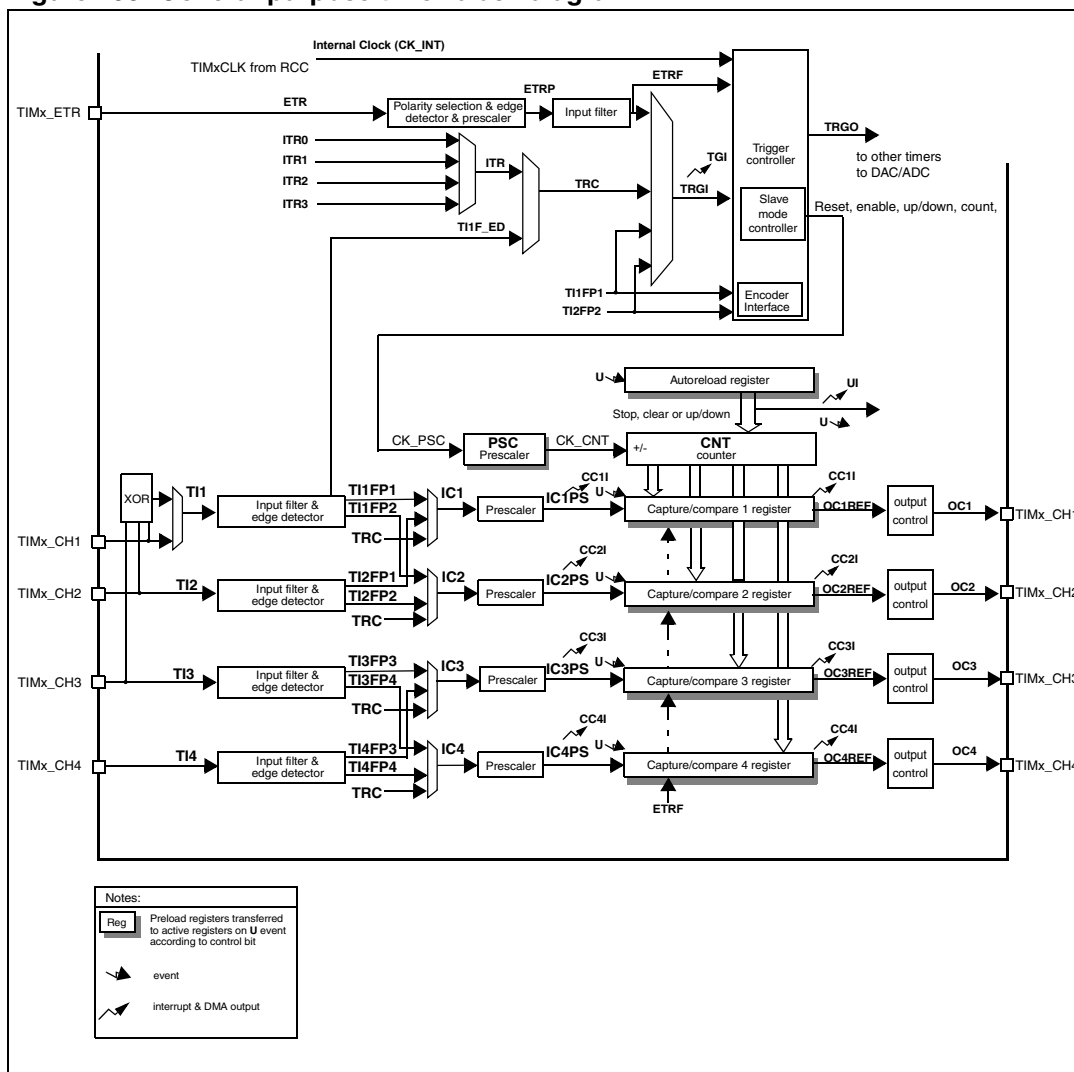
## 14.2 TIMx main features

General-purpose TIMx timer features include:

- 16-bit up, down, up/down auto-reload counter.
- 16-bit programmable prescaler used to divide (also “on the fly”) the counter clock frequency by any factor between 1 and 65535.
- Up to 4 independent channels for:
  - Input capture
  - Output compare
  - PWM generation (Edge- and Center-aligned modes)
  - One-pulse mode output
- Synchronization circuit to control the timer with external signals and to interconnect several timers.
- Interrupt/DMA generation on the following events:
  - Update: counter overflow/underflow, counter initialization (by software or internal/external trigger)
  - Trigger event (counter start, stop, initialization or count by internal/external trigger)
  - Input capture
  - Output compare
- Supports incremental (quadrature) encoder and hall-sensor circuitry for positioning purposes
- Trigger input for external clock or cycle-by-cycle current management



Figure 100. General-purpose timer block diagram



## 14.3 TIMx functional description

### 14.3.1 Time-base unit

The main block of the programmable timer is a 16-bit counter with its related auto-reload register. The counter can count up, down or both up and down. The counter clock can be divided by a prescaler.

The counter, the auto-reload register and the prescaler register can be written or read by software. This is true even when the counter is running.

The time-base unit includes:

- Counter Register (TIMx\_CNT)
- Prescaler Register (TIMx\_PSC):
- Auto-Reload Register (TIMx\_ARR)

The auto-reload register is preloaded. Writing to or reading from the auto-reload register accesses the preload register. The content of the preload register are transferred into the shadow register permanently or at each update event (UEV), depending on the auto-reload preload enable bit (ARPE) in TIMx\_CR1 register. The update event is sent when the counter reaches the overflow (or underflow when downcounting) and if the UDIS bit equals 0 in the TIMx\_CR1 register. It can also be generated by software. The generation of the update event is described in detail for each configuration.

The counter is clocked by the prescaler output CK\_CNT, which is enabled only when the counter enable bit (CEN) in TIMx\_CR1 register is set (refer also to the slave mode controller description to get more details on counter enabling).

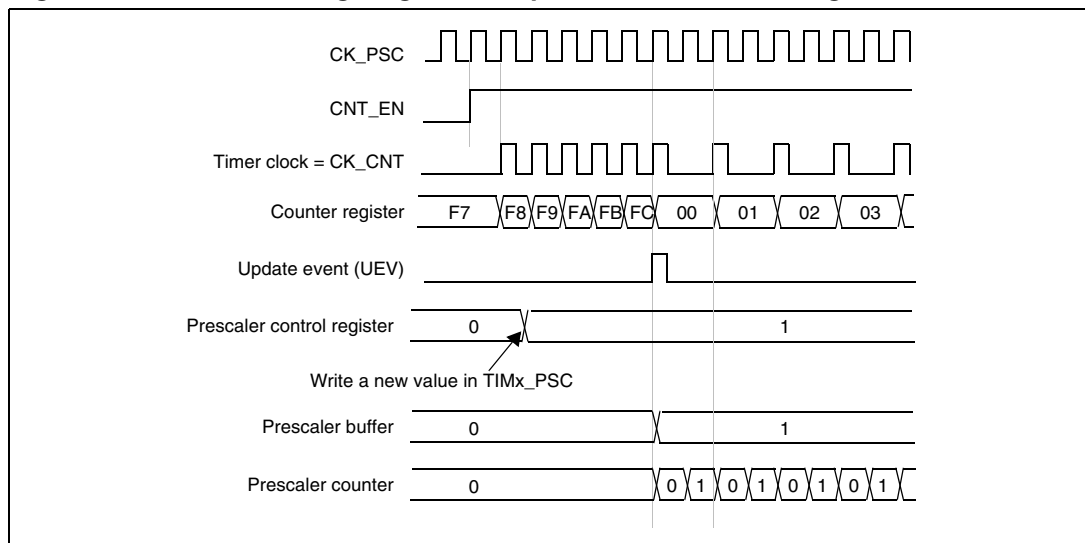
Note that the actual counter enable signal CNT\_EN is set 1 clock cycle after CEN.

**Prescaler description**

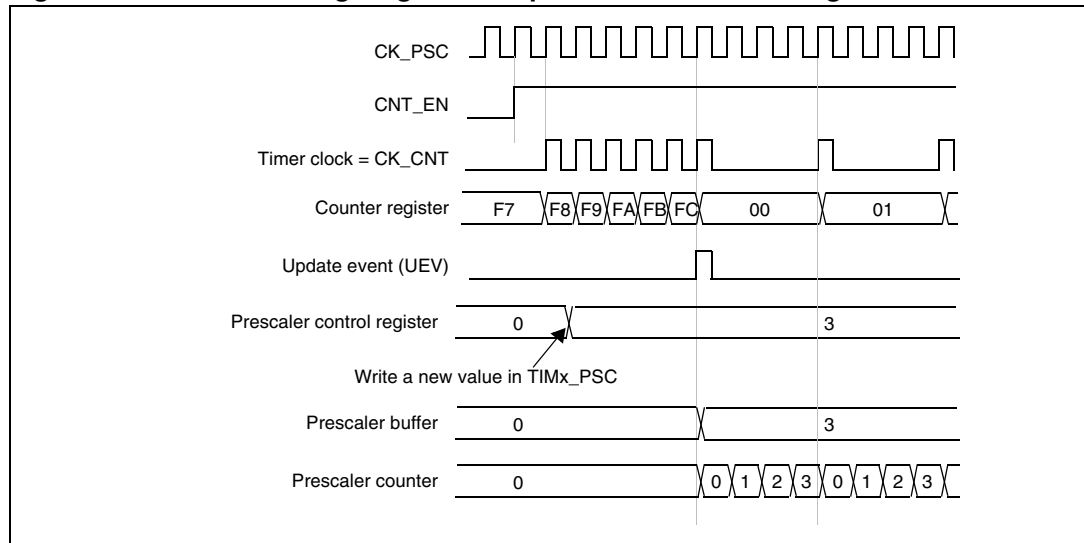
The prescaler can divide the counter clock frequency by any factor between 1 and 65536. It is based on a 16-bit counter controlled through a 16-bit register (in the TIMx\_PSC register). It can be changed on the fly as this control register is buffered. The new prescaler ratio is taken into account at the next update event.

Figure 101 and Figure 102 give some examples of the counter behavior when the prescaler ratio is changed on the fly:

**Figure 101. Counter timing diagram with prescaler division change from 1 to 2**



**Figure 102. Counter timing diagram with prescaler division change from 1 to 4**



### 14.3.2 Counter modes

#### Upcounting mode

In upcounting mode, the counter counts from 0 to the auto-reload value (content of the TIMx\_ARR register), then restarts from 0 and generates a counter overflow event.

An Update event can be generated at each counter overflow or by setting the UG bit in the TIMx\_EGR register (by software or by using the slave mode controller).

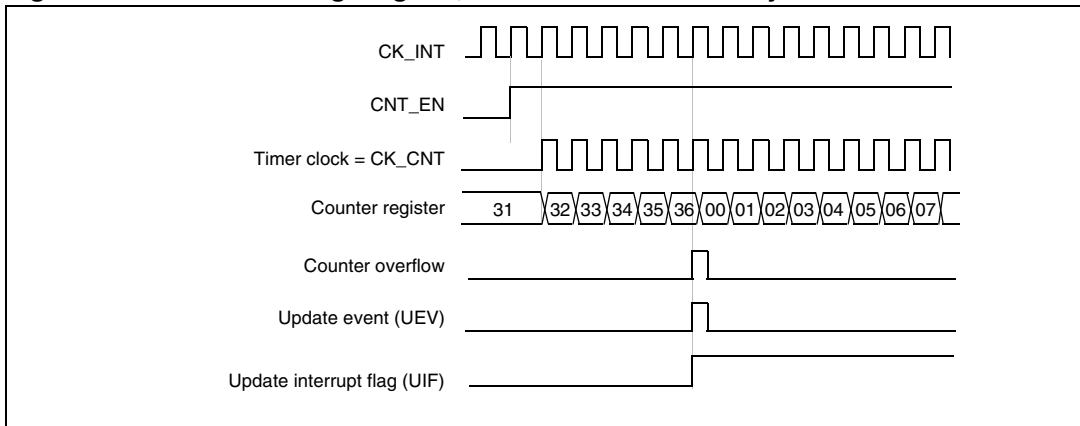
The UEV event can be disabled by software by setting the UDIS bit in TIMx\_CR1 register. This is to avoid updating the shadow registers while writing new values in the preload registers. Then no update event occurs until the UDIS bit has been written to 0. However, the counter restarts from 0, as well as the counter of the prescaler (but the prescale rate does not change). In addition, if the URS bit (update request selection) in TIMx\_CR1 register is set, setting the UG bit generates an update event UEV but without setting the UIF flag (thus no interrupt or DMA request is sent). This is to avoid generating both update and capture interrupts when clearing the counter on the capture event.

When an update event occurs, all the registers are updated and the update flag (UIF bit in TIMx\_SR register) is set (depending on the URS bit):

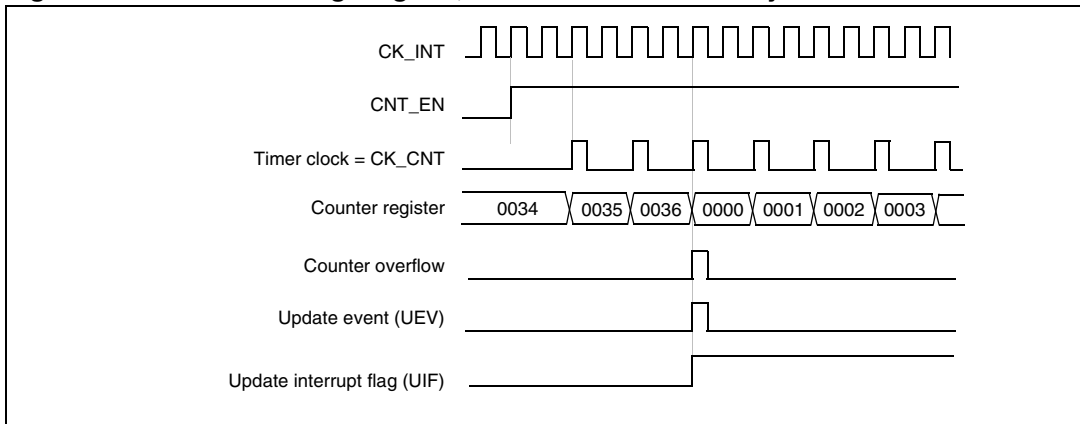
- The buffer of the prescaler is reloaded with the preload value (content of the TIMx\_PSC register)
- The auto-reload shadow register is updated with the preload value (TIMx\_ARR)

The following figures show some examples of the counter behavior for different clock frequencies when TIMx\_ARR=0x36.

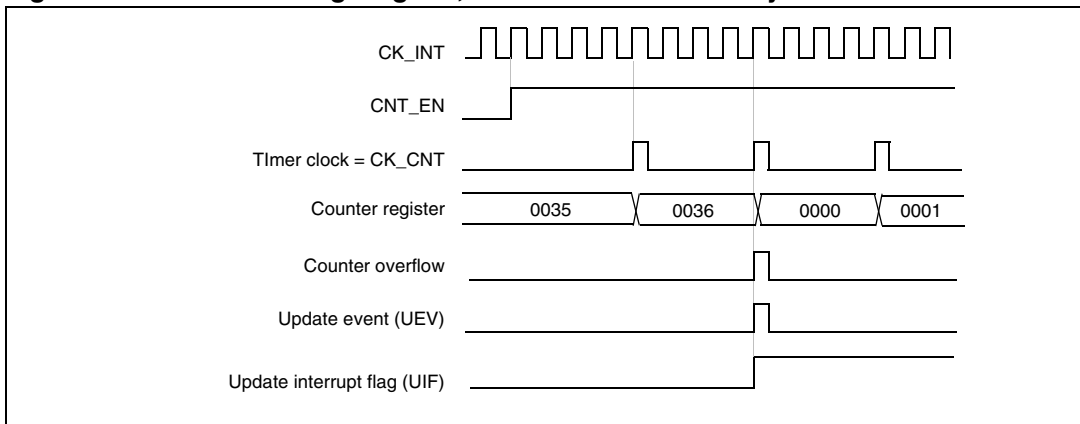
**Figure 103. Counter timing diagram, internal clock divided by 1**



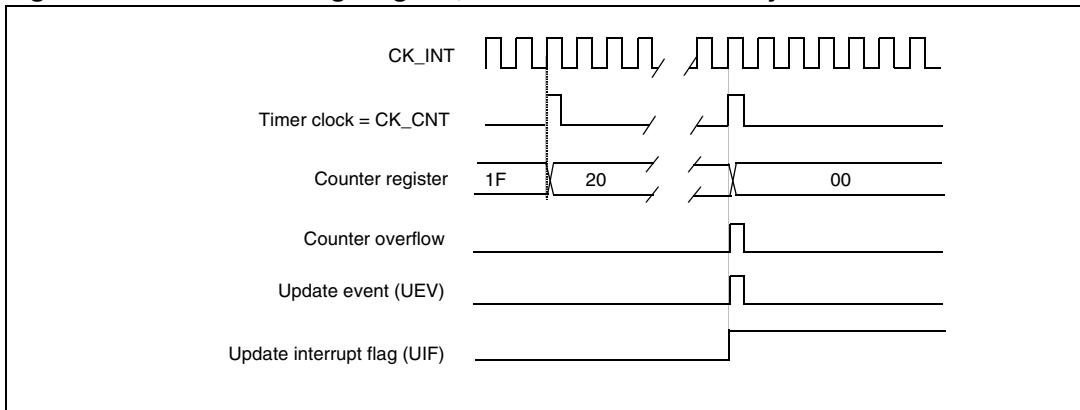
**Figure 104. Counter timing diagram, internal clock divided by 2**



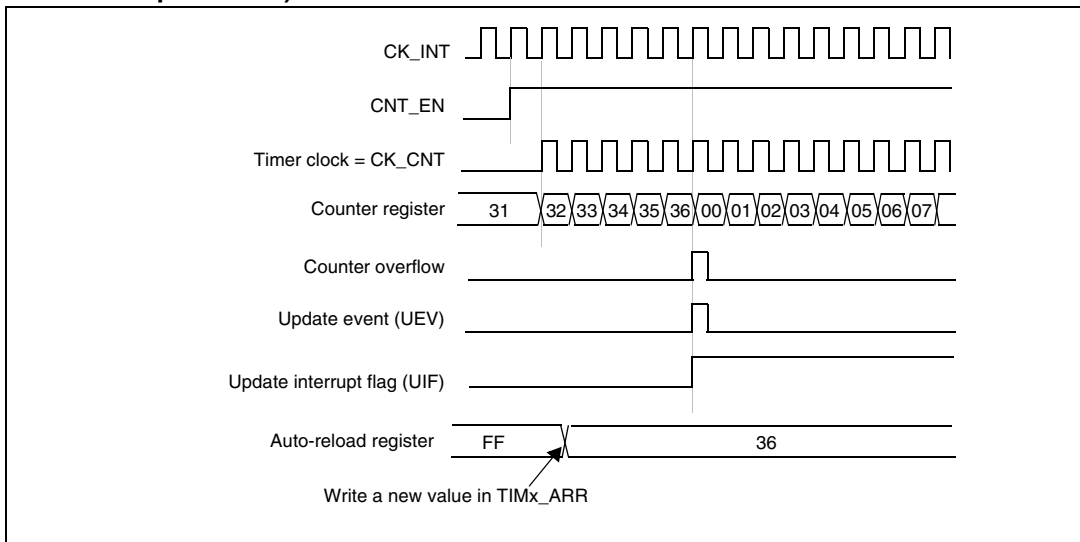
**Figure 105. Counter timing diagram, internal clock divided by 4**



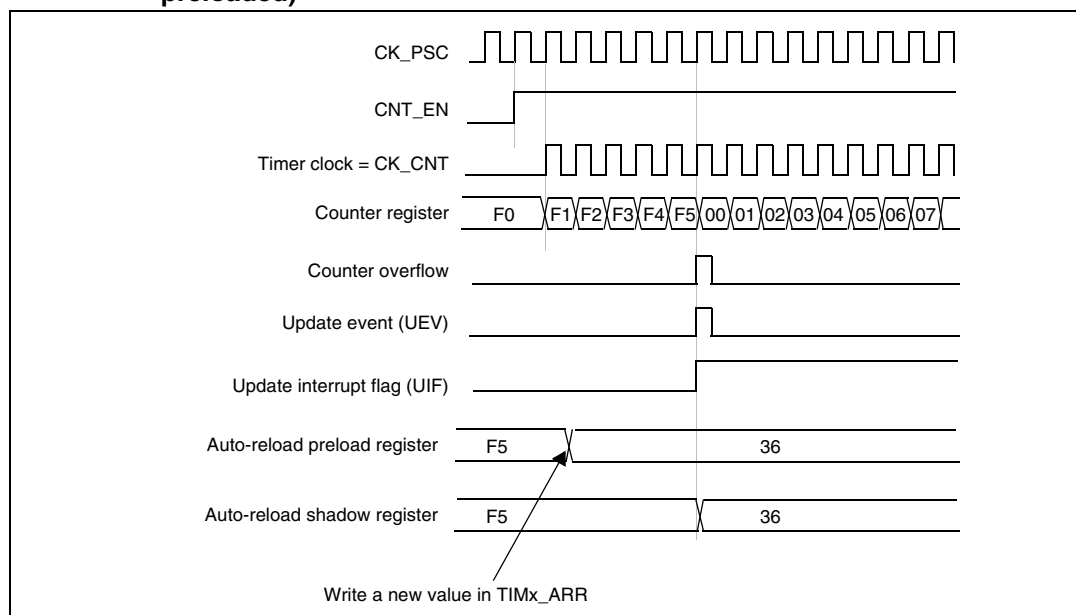
**Figure 106. Counter timing diagram, internal clock divided by N**



**Figure 107. Counter timing diagram, Update event when ARPE=0 (TIMx\_ARR not preloaded)**



**Figure 108. Counter timing diagram, Update event when ARPE=1 (TIMx\_ARR preloaded)**



**Downcounting mode**

In downcounting mode, the counter counts from the auto-reload value (content of the TIMx\_ARR register) down to 0, then restarts from the auto-reload value and generates a counter underflow event.

An Update event can be generate at each counter underflow or by setting the UG bit in the TIMx\_EGR register (by software or by using the slave mode controller)

The UEV update event can be disabled by software by setting the UDIS bit in TIMx\_CR1 register. This is to avoid updating the shadow registers while writing new values in the preload registers. Then no update event occurs until UDIS bit has been written to 0. However, the counter restarts from the current auto-reload value, whereas the counter of the prescaler restarts from 0 (but the prescale rate doesn't change).

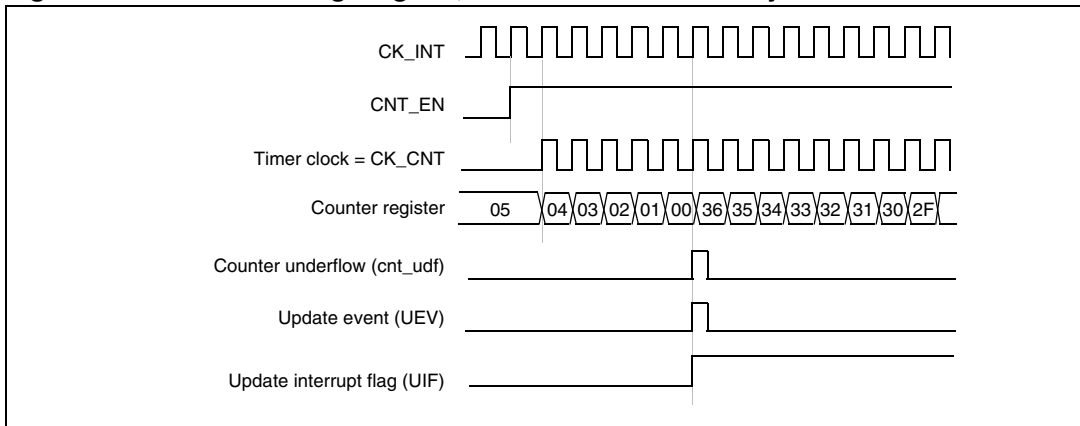
In addition, if the URS bit (update request selection) in TIMx\_CR1 register is set, setting the UG bit generates an update event UEV but without setting the UIF flag (thus no interrupt or DMA request is sent). This is to avoid generating both update and capture interrupts when clearing the counter on the capture event.

When an update event occurs, all the registers are updated and the update flag (UIF bit in TIMx\_SR register) is set (depending on the URS bit):

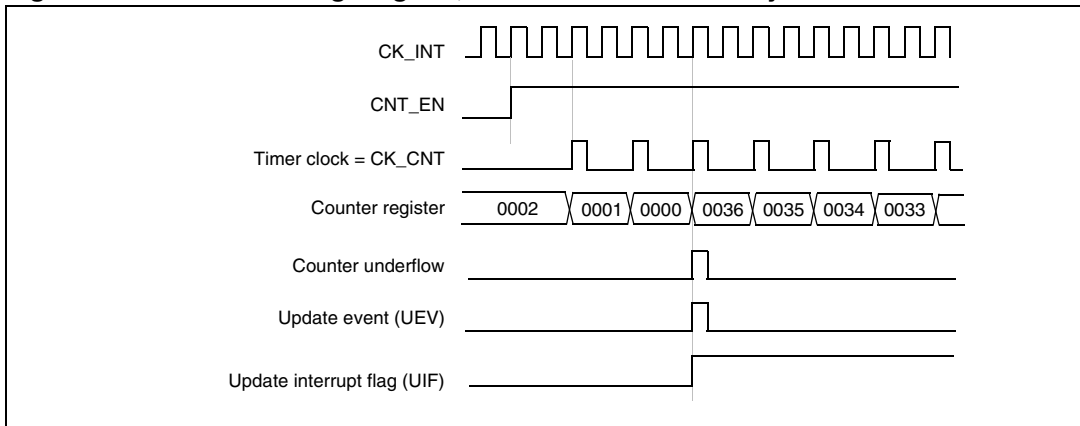
- The buffer of the prescaler is reloaded with the preload value (content of the TIMx\_PSC register).
- The auto-reload active register is updated with the preload value (content of the TIMx\_ARR register). Note that the auto-reload is updated before the counter is reloaded, so that the next period is the expected one.

The following figures show some examples of the counter behavior for different clock frequencies when TIMx\_ARR=0x36.

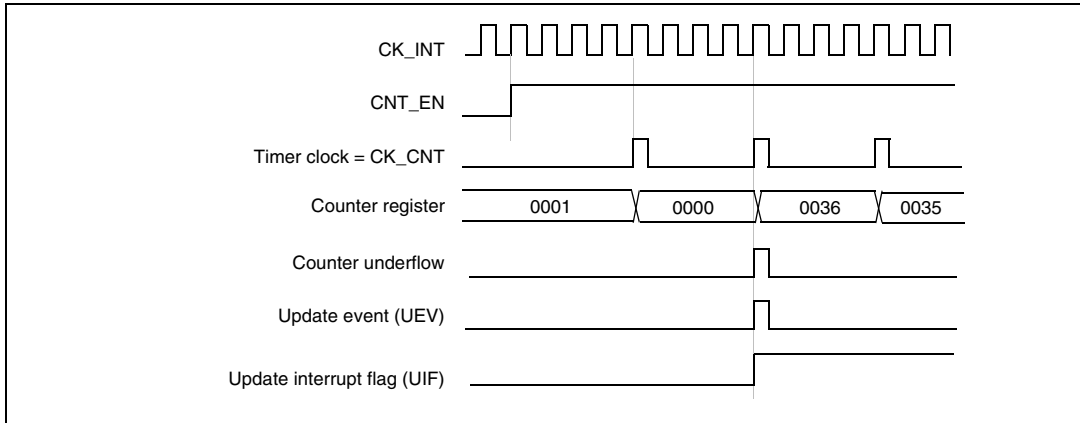
**Figure 109. Counter timing diagram, internal clock divided by 1**



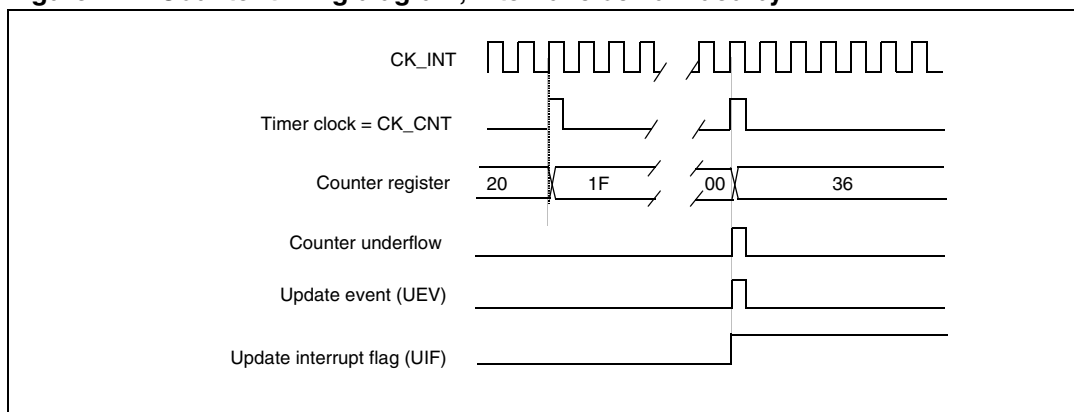
**Figure 110. Counter timing diagram, internal clock divided by 2**



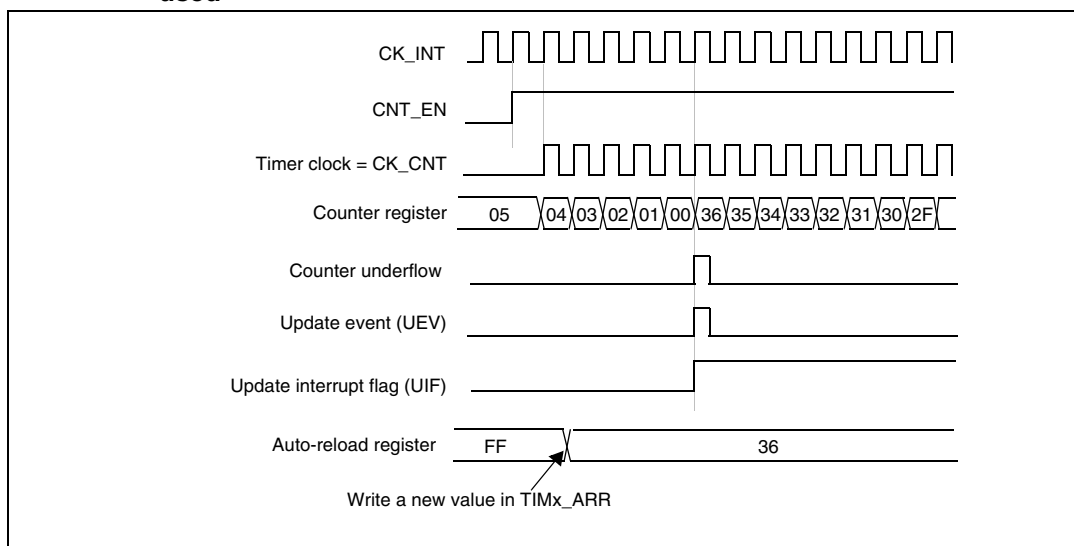
**Figure 111. Counter timing diagram, internal clock divided by 4**



**Figure 112. Counter timing diagram, internal clock divided by N**



**Figure 113. Counter timing diagram, Update event when repetition counter is not used**



**Center-aligned mode (up/down counting)**

In center-aligned mode, the counter counts from 0 to the auto-reload value (content of the TIMx\_ARR register) – 1, generates a counter overflow event, then counts from the auto-reload value down to 1 and generates a counter underflow event. Then it restarts counting from 0.

Center-aligned mode is active when the CMS bits in TIMx\_CR1 register are not equal to '00'. The Output compare interrupt flag of channels configured in output is set when: the counter counts down (Center aligned mode 1, CMS = "01"), the counter counts up (Center aligned mode 2, CMS = "10") the counter counts up and down (Center aligned mode 3, CMS = "11").

In this mode, the direction bit (DIR from TIMx\_CR1 register) cannot be written. It is updated by hardware and gives the current direction of the counter.

The update event can be generated at each counter overflow and at each counter underflow or by setting the UG bit in the TIMx\_EGR register (by software or by using the slave mode controller) also generates an update event. In this case, the counter restarts counting from 0, as well as the counter of the prescaler.



The UEV update event can be disabled by software by setting the UDIS bit in TIMx\_CR1 register. This is to avoid updating the shadow registers while writing new values in the preload registers. Then no update event occurs until the UDIS bit has been written to 0. However, the counter continues counting up and down, based on the current auto-reload value.

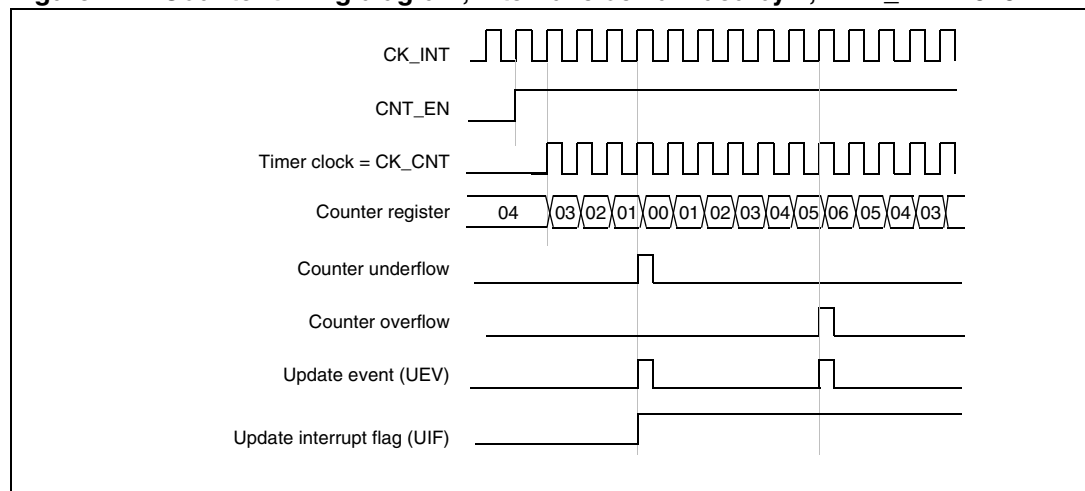
In addition, if the URS bit (update request selection) in TIMx\_CR1 register is set, setting the UG bit generates an update event UEV but without setting the UIF flag (thus no interrupt or DMA request is sent). This is to avoid generating both update and capture interrupt when clearing the counter on the capture event.

When an update event occurs, all the registers are updated and the update flag (UIF bit in TIMx\_SR register) is set (depending on the URS bit):

- The buffer of the prescaler is reloaded with the preload value (content of the TIMx\_PSC register).
- The auto-reload active register is updated with the preload value (content of the TIMx\_ARR register). Note that if the update source is a counter overflow, the auto-reload is updated before the counter is reloaded, so that the next period is the expected one (the counter is loaded with the new value).

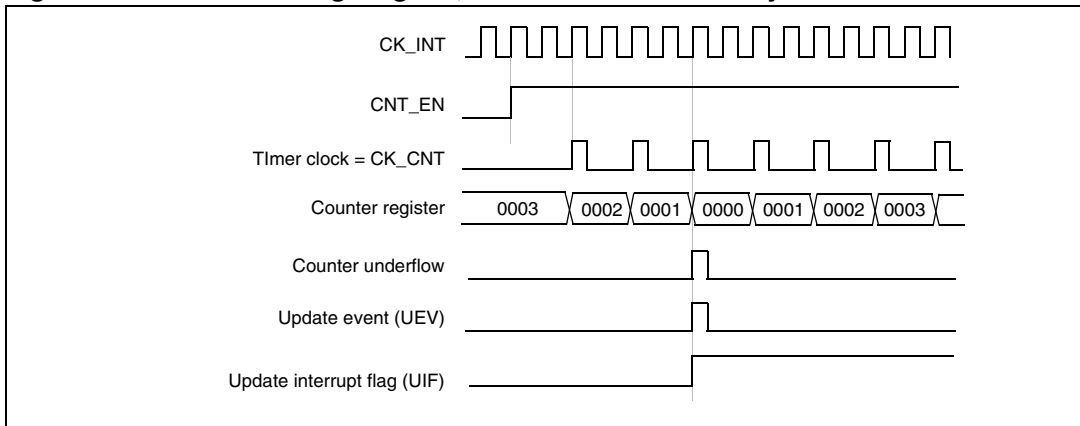
The following figures show some examples of the counter behavior for different clock frequencies.

**Figure 114. Counter timing diagram, internal clock divided by 1, TIMx\_ARR=0x6**

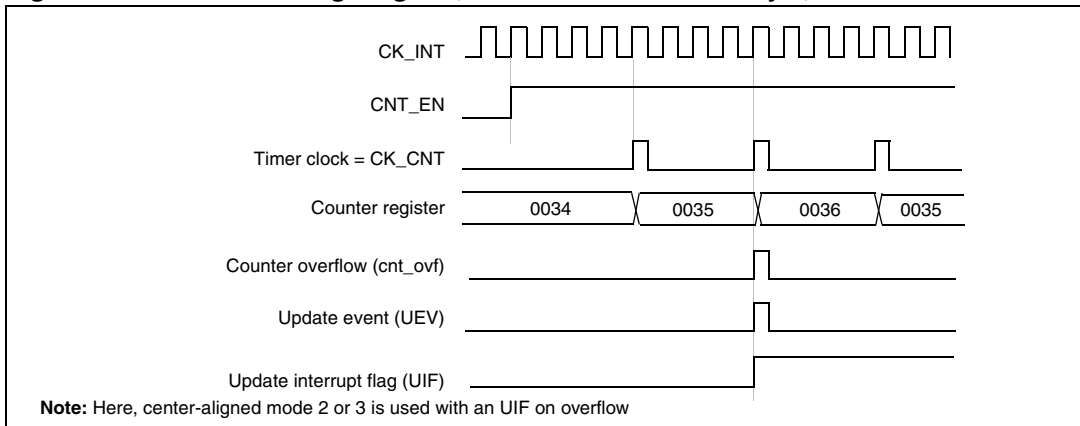


1. Here, center-aligned mode 1 is used (for more details refer to [Section 14.4.1: TIMx control register 1 \(TIMx\\_CR1\) on page 371](#)).

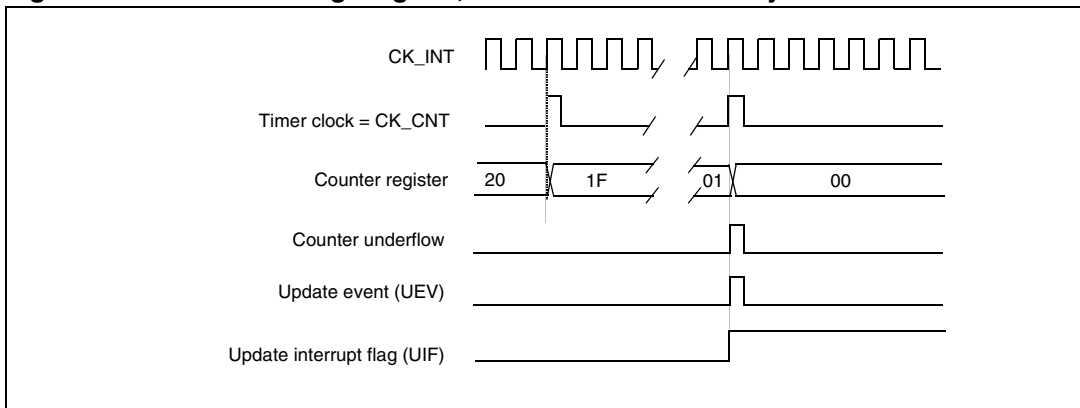
**Figure 115. Counter timing diagram, internal clock divided by 2**



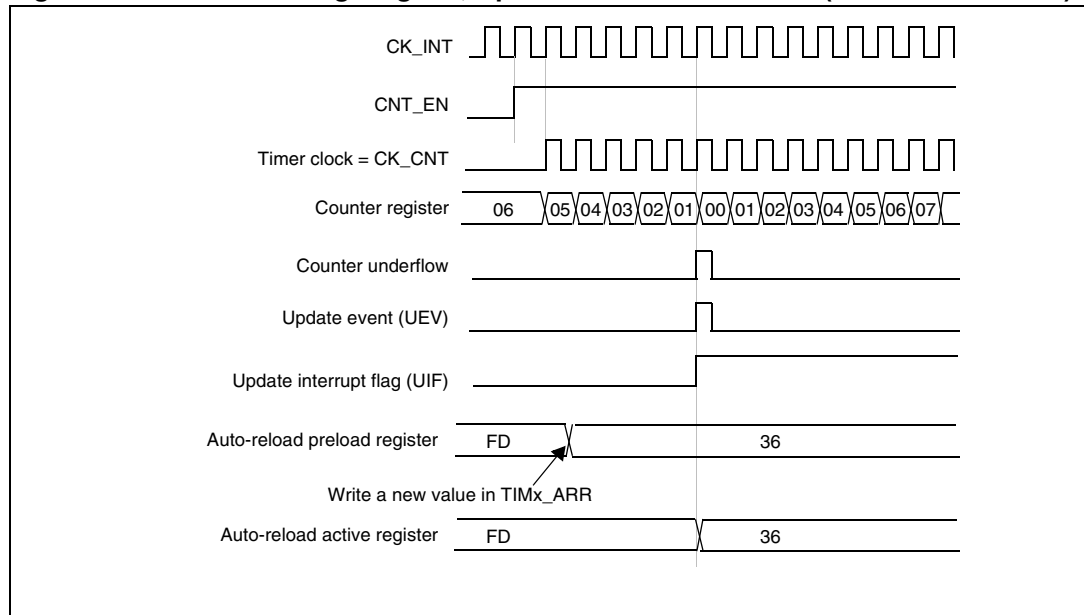
**Figure 116. Counter timing diagram, internal clock divided by 4, TIMx\_ARR=0x36**



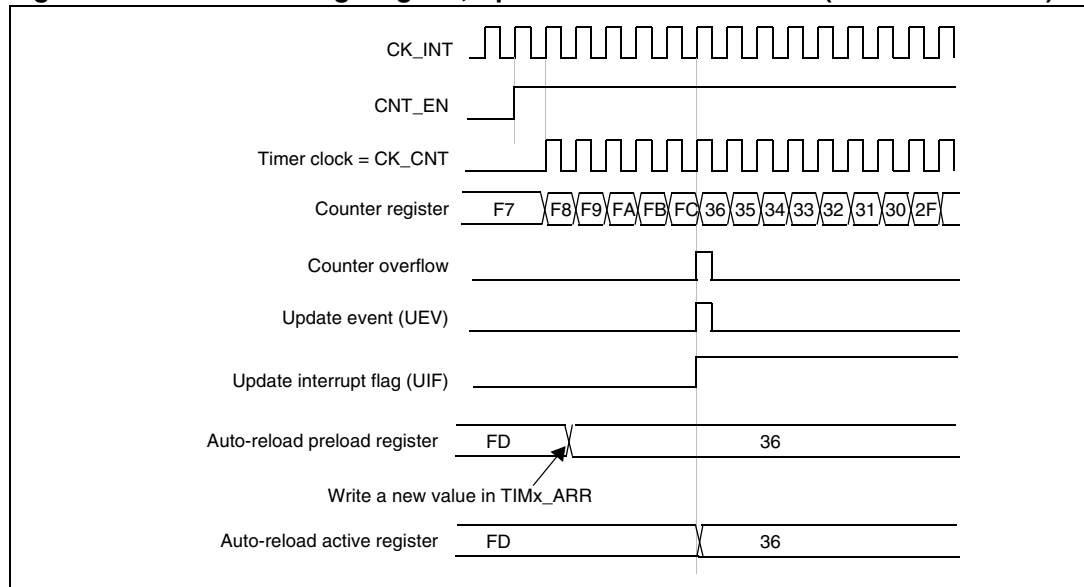
**Figure 117. Counter timing diagram, internal clock divided by N**



**Figure 118. Counter timing diagram, Update event with ARPE=1 (counter underflow)**



**Figure 119. Counter timing diagram, Update event with ARPE=1 (counter overflow)**



### 14.3.3 Clock selection

The counter clock can be provided by the following clock sources:

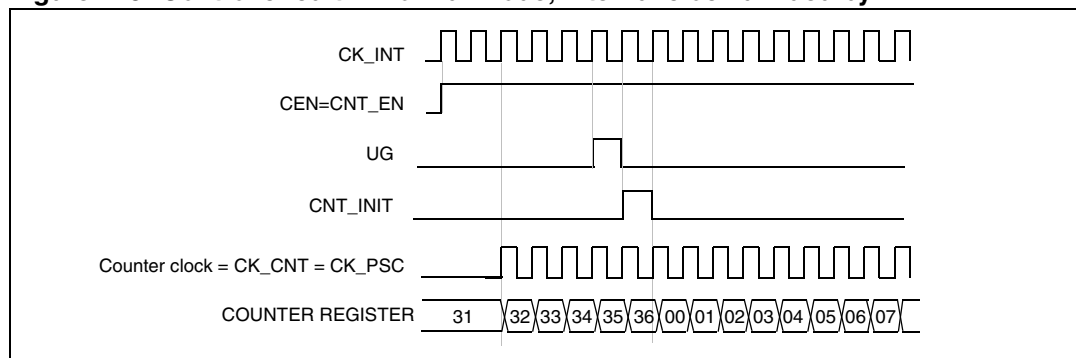
- Internal clock (CK\_INT)
- External clock mode1: external input pin (TIx)
- External clock mode2: external trigger input (ETR)
- Internal trigger inputs (ITRx): using one timer as prescaler for another timer, for example, you can configure Timer 1 to act as a prescaler for Timer 2. Refer to : [Using one timer as prescaler for another on page 366](#) for more details.

### Internal clock source (CK\_INT)

If the slave mode controller is disabled (SMS=000 in the TIMx\_SMCR register), then the CEN, DIR (in the TIMx\_CR1 register) and UG bits (in the TIMx\_EGR register) are actual control bits and can be changed only by software (except UG which remains cleared automatically). As soon as the CEN bit is written to 1, the prescaler is clocked by the internal clock CK\_INT.

Figure 120 shows the behavior of the control circuit and the upcounter in normal mode, without prescaler.

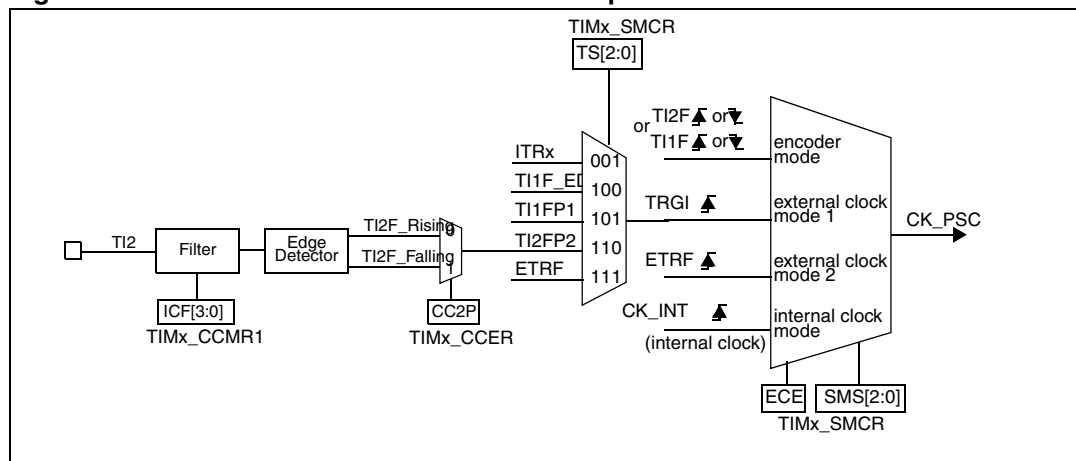
Figure 120. Control circuit in normal mode, internal clock divided by 1



### External clock source mode 1

This mode is selected when SMS=111 in the TIMx\_SMCR register. The counter can count at each rising or falling edge on a selected input.

Figure 121. TI2 external clock connection example



For example, to configure the upcounter to count in response to a rising edge on the TI2 input, use the following procedure:

For example, to configure the upcounter to count in response to a rising edge on the TI2 input, use the following procedure:

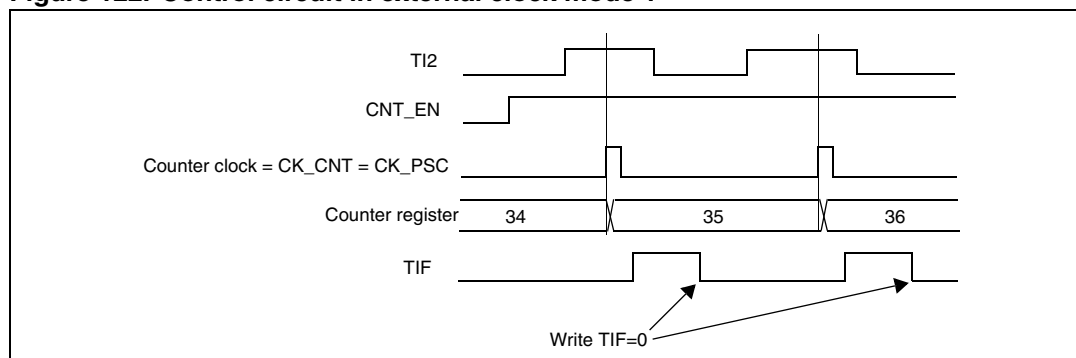
1. Configure channel 2 to detect rising edges on the TI2 input by writing CC2S= '01 in the TIMx\_CCMR1 register.
2. Configure the input filter duration by writing the IC2F[3:0] bits in the TIMx\_CCMR1 register (if no filter is needed, keep IC2F=0000).

- Note:* The capture prescaler is not used for triggering, so you don't need to configure it.
3. Select rising edge polarity by writing CC2P=0 in the TIMx\_CCER register.
  4. Configure the timer in external clock mode 1 by writing SMS=111 in the TIMx\_SMCR register.
  5. Select TI2 as the input source by writing TS=110 in the TIMx\_SMCR register.
  6. Enable the counter by writing CEN=1 in the TIMx\_CR1 register.

When a rising edge occurs on TI2, the counter counts once and the TIF flag is set.

The delay between the rising edge on TI2 and the actual clock of the counter is due to the resynchronization circuit on TI2 input.

**Figure 122. Control circuit in external clock mode 1**



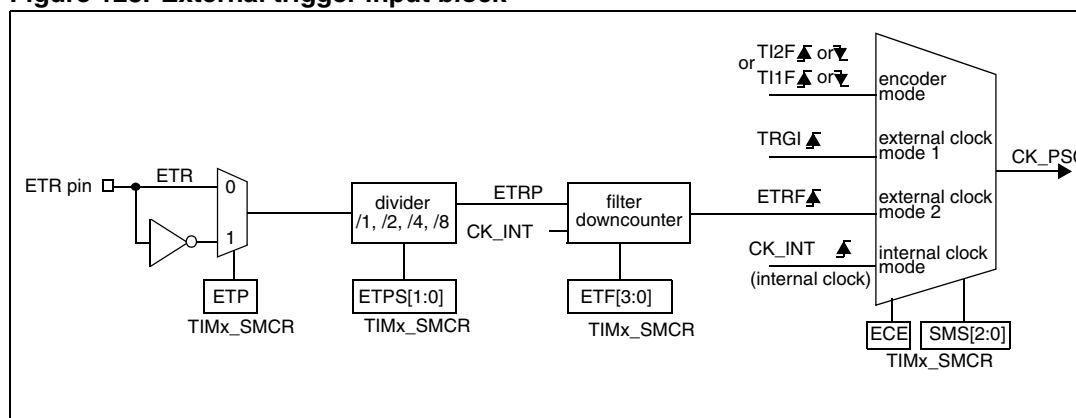
**External clock source mode 2**

This mode is selected by writing ECE=1 in the TIMx\_SMCR register.

The counter can count at each rising or falling edge on the external trigger input ETR.

The [Figure 123](#) gives an overview of the external trigger input block.

**Figure 123. External trigger input block**



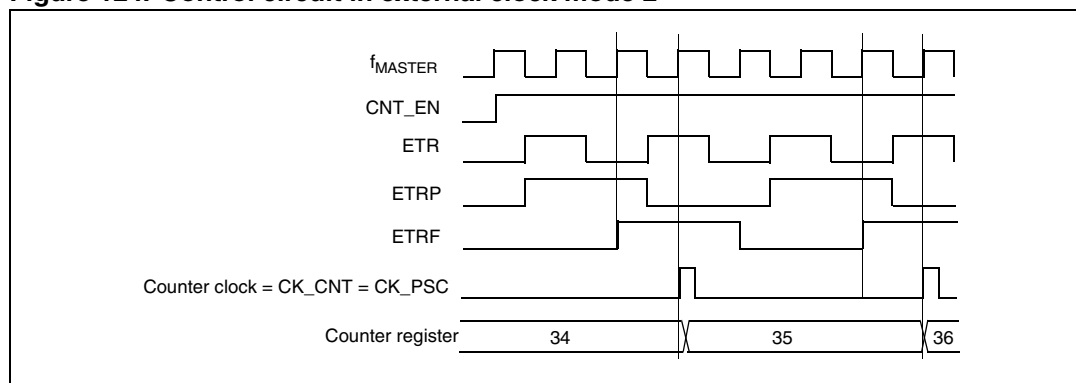
For example, to configure the upcounter to count each 2 rising edges on ETR, use the following procedure:

1. As no filter is needed in this example, write ETF[3:0]=0000 in the TIMx\_SMCR register.
2. Set the prescaler by writing ETPS[1:0]=01 in the TIMx\_SMCR register
3. Select rising edge detection on the ETR pin by writing ETP=0 in the TIMx\_SMCR register
4. Enable external clock mode 2 by writing ECE=1 in the TIMx\_SMCR register.
5. Enable the counter by writing CEN=1 in the TIMx\_CR1 register.

The counter counts once each 2 ETR rising edges.

The delay between the rising edge on ETR and the actual clock of the counter is due to the resynchronization circuit on the ETRP signal.

**Figure 124. Control circuit in external clock mode 2**



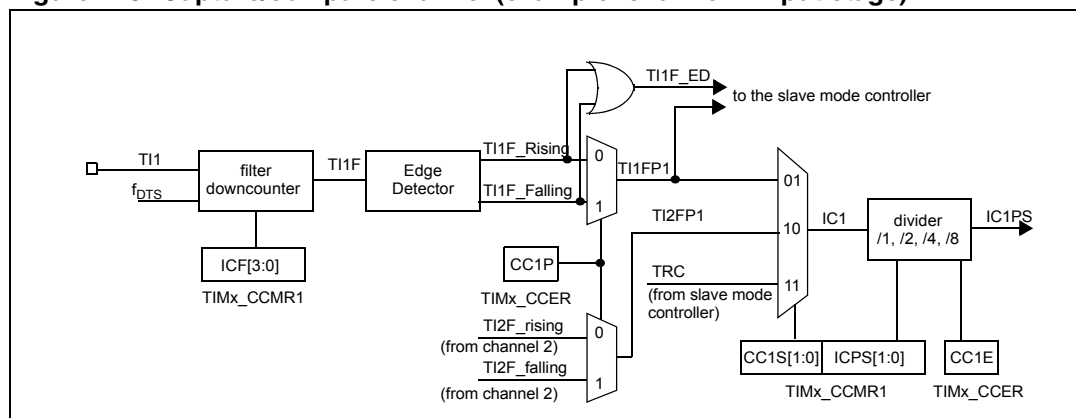
### 14.3.4 Capture/compare channels

Each Capture/Compare channel is built around a capture/compare register (including a shadow register), a input stage for capture (with digital filter, multiplexing and prescaler) and an output stage (with comparator and output control).

The following figure gives an overview of one Capture/Compare channel.

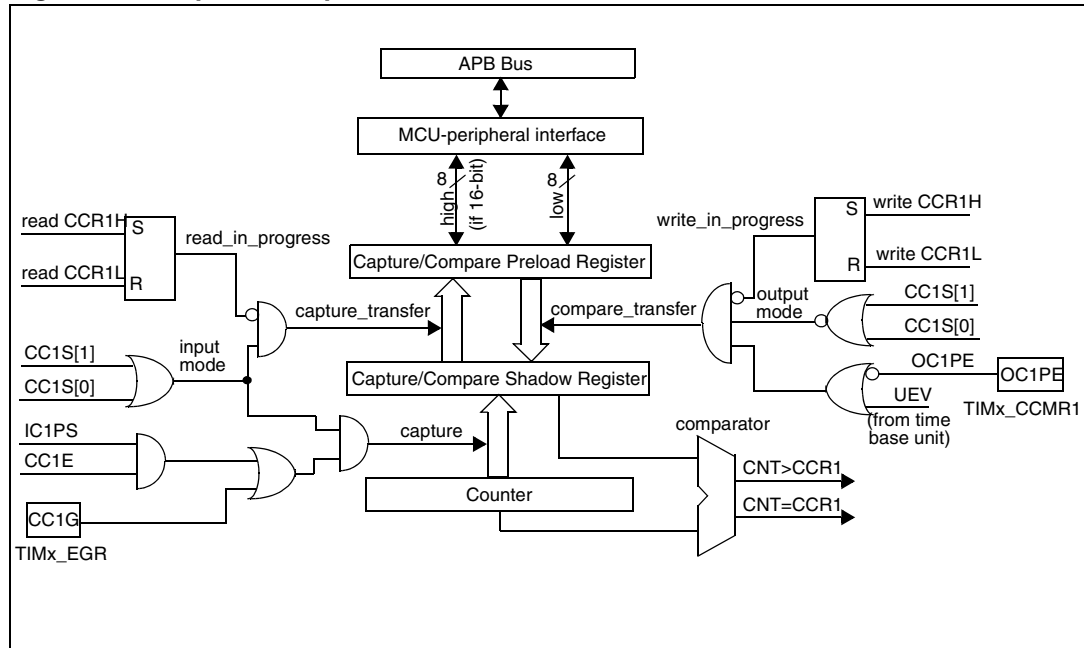
The input stage samples the corresponding Tix input to generate a filtered signal TixF. Then, an edge detector with polarity selection generates a signal (TixFPx) which can be used as trigger input by the slave mode controller or as the capture command. It is prescaled before the capture register (ICxPS).

**Figure 125. Capture/compare channel (example: channel 1 input stage)**

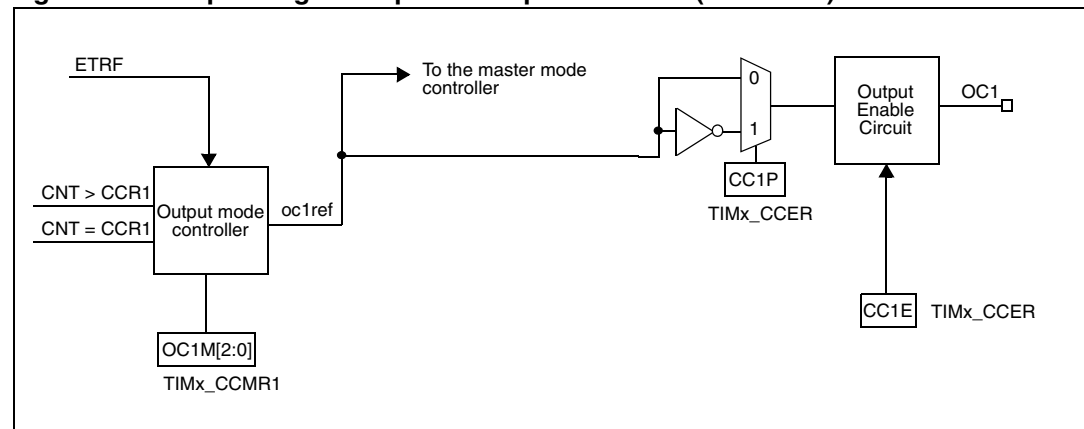


The output stage generates an intermediate waveform which is then used for reference: OCxRef (active high). The polarity acts at the end of the chain.

**Figure 126. Capture/compare channel 1 main circuit**



**Figure 127. Output stage of capture/compare channel (channel 1)**



The capture/compare block is made of one preload register and one shadow register. Write and read always access the preload register.

In capture mode, captures are actually done in the shadow register, which is copied into the preload register.

In compare mode, the content of the preload register is copied into the shadow register which is compared to the counter.

### 14.3.5 Input capture mode

In Input capture mode, the Capture/Compare Registers (TIMx\_CCRx) are used to latch the value of the counter after a transition detected by the corresponding ICx signal. When a capture occurs, the corresponding CCxIF flag (TIMx\_SR register) is set and an interrupt or a DMA request can be sent if they are enabled. If a capture occurs while the CCxIF flag was already high, then the over-capture flag CCxOF (TIMx\_SR register) is set. CCxIF can be cleared by software by writing it to 0 or by reading the captured data stored in the TIMx\_CCRx register. CCxOF is cleared when you write it to 0.

The following example shows how to capture the counter value in TIMx\_CCR1 when TI1 input rises. To do this, use the following procedure:

- Select the active input: TIMx\_CCR1 must be linked to the TI1 input, so write the CC1S bits to 01 in the TIMx\_CCMR1 register. As soon as CC1S becomes different from 00, the channel is configured in input and the TIMx\_CCR1 register becomes read-only.
- Program the input filter duration you need with respect to the signal you connect to the timer (when the input is one of the TIx (ICxF bits in the TIMx\_CCMRx register). Let's imagine that, when toggling, the input signal is not stable during at most 5 internal clock cycles. We must program a filter duration longer than these 5 clock cycles. We can validate a transition on TI1 when 8 consecutive samples with the new level have been detected (sampled at  $f_{DTS}$  frequency). Then write IC1F bits to 0011 in the TIMx\_CCMR1 register.
- Select the edge of the active transition on the TI1 channel by writing CC1P bit to 0 in the TIMx\_CCER register (rising edge in this case).
- Program the input prescaler. In our example, we wish the capture to be performed at each valid transition, so the prescaler is disabled (write IC1PS bits to 00 in the TIMx\_CCMR1 register).
- Enable capture from the counter into the capture register by setting the CC1E bit in the TIMx\_CCER register.
- If needed, enable the related interrupt request by setting the CC1IE bit in the TIMx\_DIER register, and/or the DMA request by setting the CC1DE bit in the TIMx\_DIER register.

When an input capture occurs:

- The TIMx\_CCR1 register gets the value of the counter on the active transition.
- CC1IF flag is set (interrupt flag). CC1OF is also set if at least two consecutive captures occurred whereas the flag was not cleared.
- An interrupt is generated depending on the CC1IE bit.
- A DMA request is generated depending on the CC1DE bit.

In order to handle the overcapture, it is recommended to read the data before the overcapture flag. This is to avoid missing an overcapture which could happen after reading the flag and before reading the data.

*Note:* IC interrupt and/or DMA requests can be generated by software by setting the corresponding CCxG bit in the TIMx\_EGR register.



### 14.3.6 PWM input mode

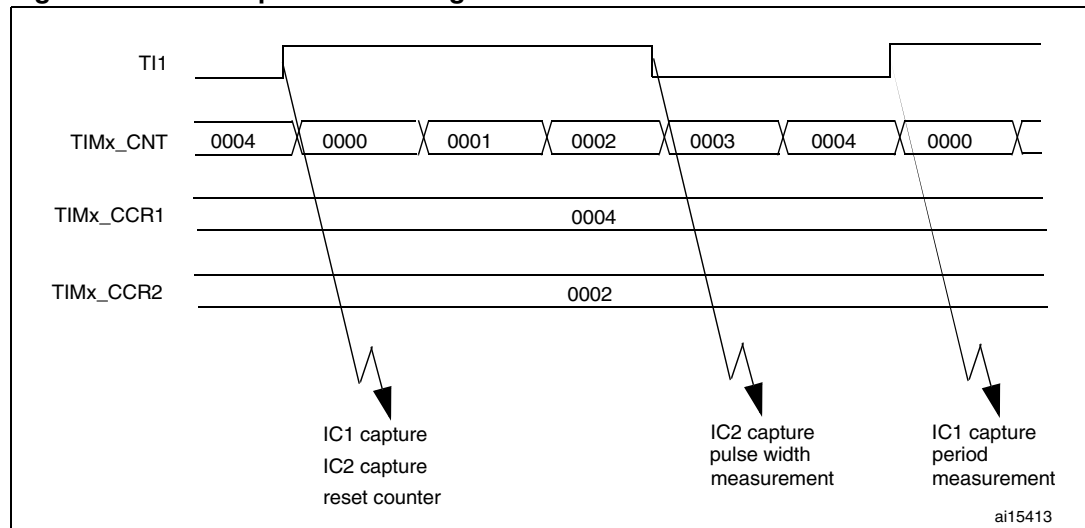
This mode is a particular case of input capture mode. The procedure is the same except:

- Two ICx signals are mapped on the same TIx input.
- These 2 ICx signals are active on edges with opposite polarity.
- One of the two TIxFP signals is selected as trigger input and the slave mode controller is configured in reset mode.

For example, you can measure the period (in TIMx\_CCR1 register) and the duty cycle (in TIMx\_CCR2 register) of the PWM applied on TI1 using the following procedure (depending on CK\_INT frequency and prescaler value):

- Select the active input for TIMx\_CCR1: write the CC1S bits to 01 in the TIMx\_CCMR1 register (TI1 selected).
- Select the active polarity for TI1FP1 (used both for capture in TIMx\_CCR1 and counter clear): write the CC1P bit to 0 (active on rising edge).
- Select the active input for TIMx\_CCR2: write the CC2S bits to 10 in the TIMx\_CCMR1 register (TI1 selected).
- Select the active polarity for TI1FP2 (used for capture in TIMx\_CCR2): write the CC2P bit to '1' (active on falling edge).
- Select the valid trigger input: write the TS bits to 101 in the TIMx\_SMCR register (TI1FP1 selected).
- Configure the slave mode controller in reset mode: write the SMS bits to 100 in the TIMx\_SMCR register.
- Enable the captures: write the CC1E and CC2E bits to '1' in the TIMx\_CCER register.

**Figure 128. PWM input mode timing**



1. The PWM input mode can be used only with the TIMx\_CH1/TIMx\_CH2 signals due to the fact that only TI1FP1 and TI2FP2 are connected to the slave mode controller.

### 14.3.7 Forced output mode

In output mode (CCxS bits = 00 in the TIMx\_CCMRx register), each output compare signal (OCxREF and then OCx) can be forced to active or inactive level directly by software, independently of any comparison between the output compare register and the counter.

To force an output compare signal (ocxref/OCx) to its active level, you just need to write 101 in the OCxM bits in the corresponding TIMx\_CCMRx register. Thus ocxref is forced high (OCxREF is always active high) and OCx get opposite value to CCxP polarity bit.

e.g.: CCxP=0 (OCx active high) => OCx is forced to high level.

ocxref signal can be forced low by writing the OCxM bits to 100 in the TIMx\_CCMRx register.

Anyway, the comparison between the TIMx\_CCRx shadow register and the counter is still performed and allows the flag to be set. Interrupt and DMA requests can be sent accordingly. This is described in the Output Compare Mode section.

### 14.3.8 Output compare mode

This function is used to control an output waveform or indicating when a period of time has elapsed.

When a match is found between the capture/compare register and the counter, the output compare function:

- Assigns the corresponding output pin to a programmable value defined by the output compare mode (OCxM bits in the TIMx\_CCMRx register) and the output polarity (CCxP bit in the TIMx\_CCER register). The output pin can keep its level (OCxM=000), be set active (OCxM=001), be set inactive (OCxM=010) or can toggle (OCxM=011) on match.
- Sets a flag in the interrupt status register (CCxIF bit in the TIMx\_SR register).
- Generates an interrupt if the corresponding interrupt mask is set (CCxIE bit in the TIMx\_DIER register).
- Sends a DMA request if the corresponding enable bit is set (CCxDE bit in the TIMx\_DIER register, CCDS bit in the TIMx\_CR2 register for the DMA request selection).

The TIMx\_CCRx registers can be programmed with or without preload registers using the OCxPE bit in the TIMx\_CCMRx register.

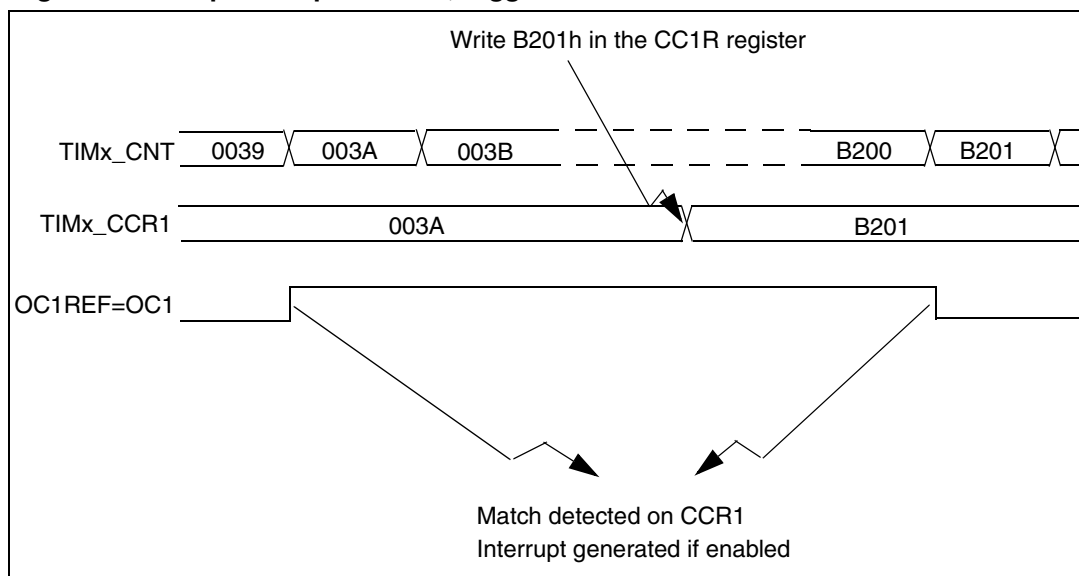
In output compare mode, the update event UEV has no effect on ocxref and OCx output. The timing resolution is one count of the counter. Output compare mode can also be used to output a single pulse (in One-pulse mode).

Procedure:

1. Select the counter clock (internal, external, prescaler).
2. Write the desired data in the TIMx\_ARR and TIMx\_CCRx registers.
3. Set the CCxIE and/or CCxDE bits if an interrupt and/or a DMA request is to be generated.
4. Select the output mode. For example, you must write OCxM=011, OCxPE=0, CCxP=0 and CCxE=1 to toggle OCx output pin when CNT matches CCRx, CCRx preload is not used, OCx is enabled and active high.
5. Enable the counter by setting the CEN bit in the TIMx\_CR1 register.

The TIMx\_CCRx register can be updated at any time by software to control the output waveform, provided that the preload register is not enabled (OCxPE=0, else TIMx\_CCRx shadow register is updated only at the next update event UEV). An example is given in [Figure 129](#).

**Figure 129. Output compare mode, toggle on OC1.**



### 14.3.9 PWM mode

Pulse width modulation mode allows you to generate a signal with a frequency determined by the value of the TIMx\_ARR register and a duty cycle determined by the value of the TIMx\_CCRx register.

The PWM mode can be selected independently on each channel (one PWM per OCx output) by writing 110 (PWM mode 1) or '111 (PWM mode 2) in the OCxM bits in the TIMx\_CCMRx register. You must enable the corresponding preload register by setting the OCxPE bit in the TIMx\_CCMRx register, and eventually the auto-reload preload register (in upcounting or center-aligned modes) by setting the ARPE bit in the TIMx\_CR1 register.

As the preload registers are transferred to the shadow registers only when an update event occurs, before starting the counter, you have to initialize all the registers by setting the UG bit in the TIMx\_EGR register.

OCx polarity is software programmable using the CCxP bit in the TIMx\_CCER register. It can be programmed as active high or active low. OCx output is enabled by the CCxE bit in the TIMx\_CCER register. Refer to the TIMx\_CCERx register description for more details.

In PWM mode (1 or 2), TIMx\_CNT and TIMx\_CCRx are always compared to determine whether  $TIMx\_CCRx \leq TIMx\_CNT$  or  $TIMx\_CNT \leq TIMx\_CCRx$  (depending on the direction of the counter). However, to comply with the OCREF\_CLR functionality (OCREF can be cleared by an external event through the ETR signal until the next PWM period), the OCREF signal is asserted only:

- When the result of the comparison changes, or
- When the output compare mode (OCxM bits in TIMx\_CCMRx register) switches from the "frozen" configuration (no comparison, OCxM='000) to one of the PWM modes (OCxM='110 or '111).

This forces the PWM by software while the timer is running.

The timer is able to generate PWM in edge-aligned mode or center-aligned mode depending on the CMS bits in the TIMx\_CR1 register.

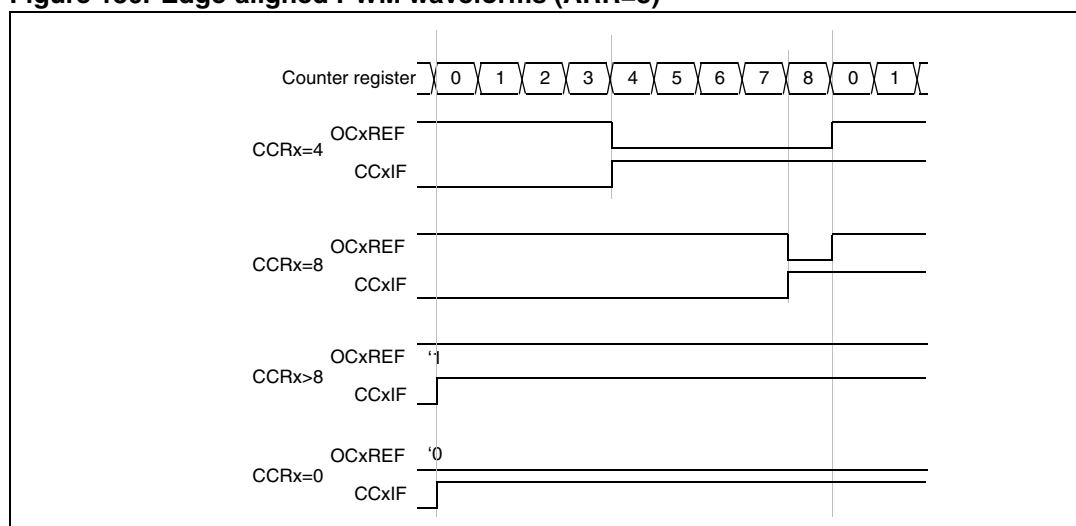
### PWM edge-aligned mode

Upcounting configuration

Upcounting is active when the DIR bit in the TIMx\_CR1 register is low. Refer to the [Section : Upcounting mode on page 339](#).

In the following example, we consider PWM mode 1. The reference PWM signal OCxREF is high as long as  $TIMx\_CNT < TIMx\_CCRx$  else it becomes low. If the compare value in TIMx\_CCRx is greater than the auto-reload value (in TIMx\_ARR) then OCxREF is held at '1. If the compare value is 0 then OCxREF is held at '0. [Figure 130](#) shows some edge-aligned PWM waveforms in an example where  $TIMx\_ARR=8$ .

**Figure 130. Edge-aligned PWM waveforms (ARR=8)**



### Downcounting configuration

Downcounting is active when DIR bit in TIMx\_CR1 register is high. Refer to [Downcounting mode on page 342](#)

In PWM mode 1, the reference signal ocxref is low as long as  $TIMx\_CNT > TIMx\_CCRx$  else it becomes high. If the compare value in TIMx\_CCRx is greater than the auto-reload value in TIMx\_ARR, then ocxref is held at '1. 0% PWM is not possible in this mode.

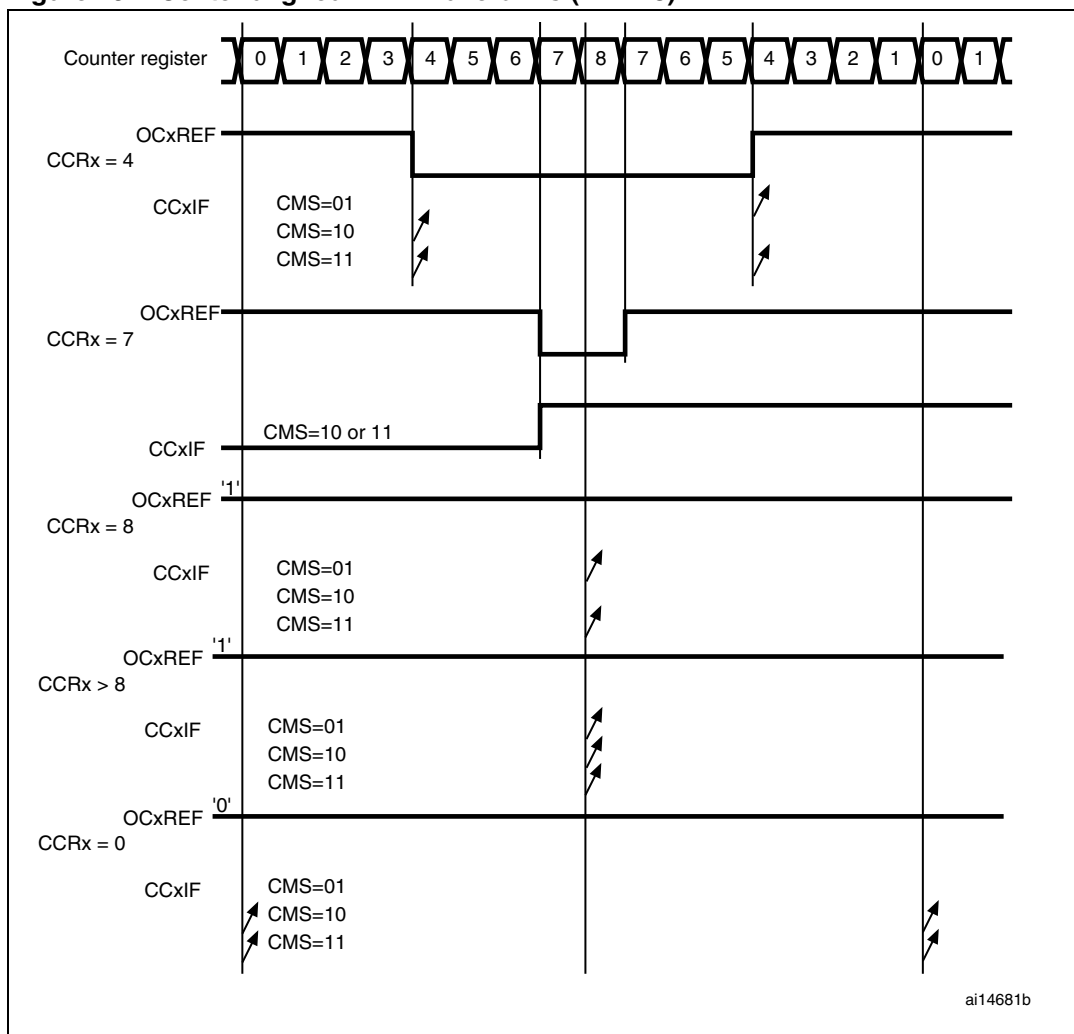
### PWM center-aligned mode

Center-aligned mode is active when the CMS bits in TIMx\_CR1 register are different from '00 (all the remaining configurations having the same effect on the ocxref/OCx signals). The compare flag is set when the counter counts up, when it counts down or both when it counts up and down depending on the CMS bits configuration. The direction bit (DIR) in the TIMx\_CR1 register is updated by hardware and must not be changed by software. Refer to the [Center-aligned mode \(up/down counting\) on page 344](#).

Figure 131 shows some center-aligned PWM waveforms in an example where:

- TIMx\_ARR=8,
- PWM mode is the PWM mode 1,
- The flag is set when the counter counts down corresponding to the center-aligned mode 1 selected for CMS=01 in TIMx\_CR1 register.

**Figure 131. Center-aligned PWM waveforms (ARR=8)**



Hints on using center-aligned mode:

- When starting in center-aligned mode, the current up-down configuration is used. It means that the counter counts up or down depending on the value written in the DIR bit in the TIMx\_CR1 register. Moreover, the DIR and CMS bits must not be changed at the same time by the software.
- Writing to the counter while running in center-aligned mode is not recommended as it can lead to unexpected results. In particular:
  - The direction is not updated if you write a value in the counter that is greater than the auto-reload value (TIMx\_CNT>TIMx\_ARR). For example, if the counter was counting up, it continues to count up.

- The direction is updated if you write 0 or write the TIMx\_ARR value in the counter but no Update Event UEV is generated.
- The safest way to use center-aligned mode is to generate an update by software (setting the UG bit in the TIMx\_EGR register) just before starting the counter and not to write the counter while it is running.

### 14.3.10 One-pulse mode

One-pulse mode (OPM) is a particular case of the previous modes. It allows the counter to be started in response to a stimulus and to generate a pulse with a programmable length after a programmable delay.

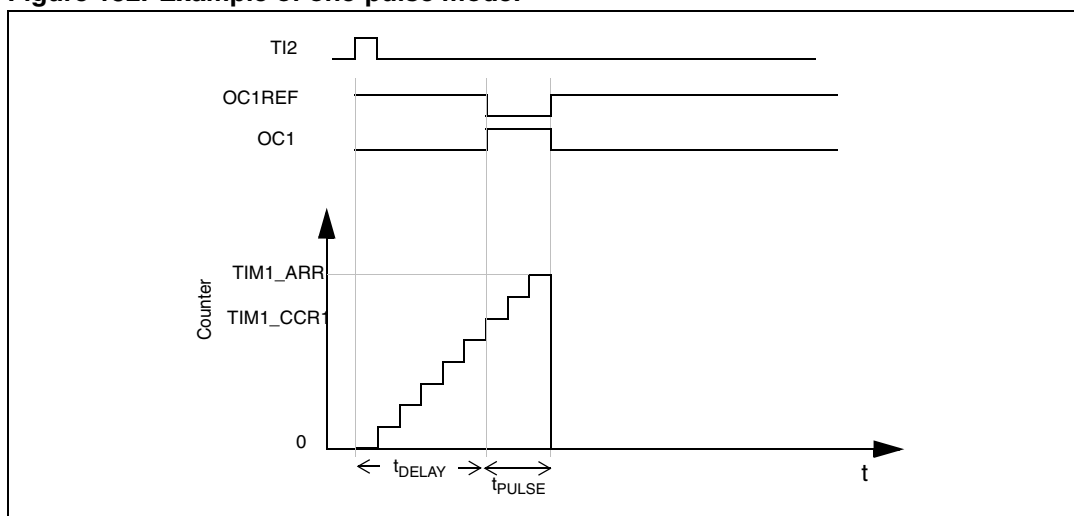
Starting the counter can be controlled through the slave mode controller. Generating the waveform can be done in output compare mode or PWM mode. You select One-pulse mode by setting the OPM bit in the TIMx\_CR1 register. This makes the counter stop automatically at the next update event UEV.

A pulse can be correctly generated only if the compare value is different from the counter initial value. Before starting (when the timer is waiting for the trigger), the configuration must be:

In upcounting:  $CNT < CCRx \leq ARR$  (in particular,  $0 < CCRx$ ),

In downcounting:  $CNT > CCRx$ .

**Figure 132. Example of one-pulse mode.**



For example you may want to generate a positive pulse on OC1 with a length of  $t_{PULSE}$  and after a delay of  $t_{DELAY}$  as soon as a positive edge is detected on the TI2 input pin.

Let's use TI2FP2 as trigger 1:

- Map TI2FP2 on TI2 by writing IC2S=01 in the TIMx\_CCMR1 register.
- TI2FP2 must detect a rising edge, write CC2P=0 in the TIMx\_CCER register.
- Configure TI2FP2 as trigger for the slave mode controller (TRGI) by writing TS=110 in the TIMx\_SMCR register.
- TI2FP2 is used to start the counter by writing SMS to '110 in the TIMx\_SMCR register (trigger mode).

The OPM waveform is defined by writing the compare registers (taking into account the clock frequency and the counter prescaler).

- The  $t_{\text{DELAY}}$  is defined by the value written in the TIMx\_CCR1 register.
- The  $t_{\text{PULSE}}$  is defined by the difference between the auto-reload value and the compare value (TIMx\_ARR - TIMx\_CCR1).
- Let's say you want to build a waveform with a transition from '0 to '1 when a compare match occurs and a transition from '1 to '0 when the counter reaches the auto-reload value. To do this you enable PWM mode 2 by writing OC1M=111 in the TIMx\_CCMR1 register. You can optionally enable the preload registers by writing OC1PE=1 in the TIMx\_CCMR1 register and ARPE in the TIMx\_CR1 register. In this case you have to write the compare value in the TIMx\_CCR1 register, the auto-reload value in the TIMx\_ARR register, generate an update by setting the UG bit and wait for external trigger event on TI2. CC1P is written to '0 in this example.

In our example, the DIR and CMS bits in the TIMx\_CR1 register should be low.

You only want 1 pulse(Single mode), so you write '1 in the OPM bit in the TIMx\_CR1 register to stop the counter at the next update event (when the counter rolls over from the auto-reload value back to 0). When OPM bit in the TIMx\_CR1 register is set to '0', so the Repetitive Mode is selected.

#### Particular case: OCx fast enable:

In One-pulse mode, the edge detection on TIx input set the CEN bit which enables the counter. Then the comparison between the counter and the compare value makes the output toggle. But several clock cycles are needed for these operations and it limits the minimum delay  $t_{\text{DELAY}}$  min we can get.

If you want to output a waveform with the minimum delay, you can set the OCxFE bit in the TIMx\_CCMRx register. Then OCxRef (and OCx) is forced in response to the stimulus, without taking in account the comparison. Its new level is the same as if a compare match had occurred. OCxFE acts only if the channel is configured in PWM1 or PWM2 mode.

### 14.3.11 Clearing the OCxREF signal on an external event

The OCxREF signal for a given channel can be reset by applying a high level on the ETRF input (OCxCE enable bit set to 1 in the corresponding TIMx\_CCMRx register). OCxREF remains low until the next update event (UEV) occurs.

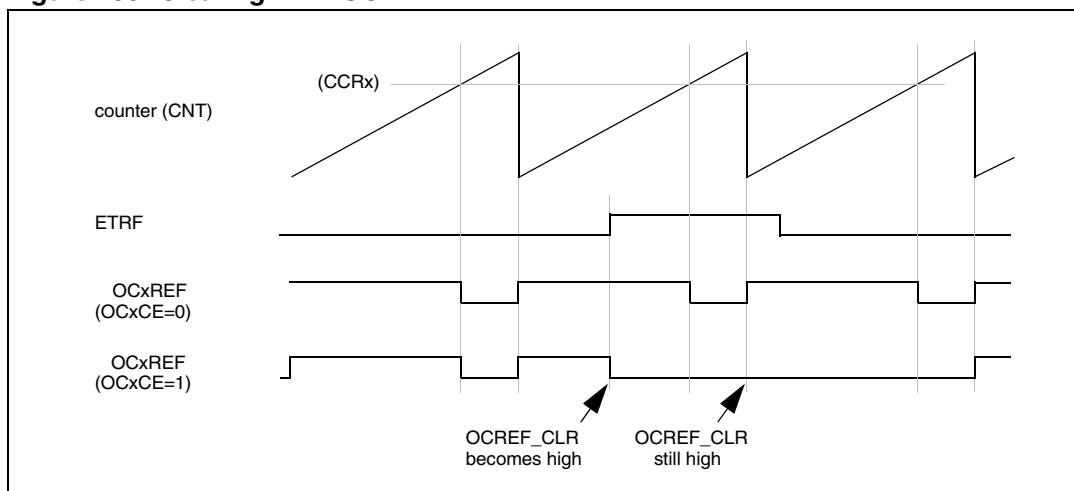
This function can be used only in the output compare and PWM modes. It does not work in forced mode.

For example, the OCxREF signal can be connected to the output of a comparator to be used for current handling. In this case, ETR must be configured as follows:

1. The external trigger prescaler should be kept off: bits ETPS[1:0] in the TIMx\_SMCR register are cleared to 00.
2. The external clock mode 2 must be disabled: bit ECE in the TIM1\_SMCR register is cleared to 0.
3. The external trigger polarity (ETP) and the external trigger filter (ETF) can be configured according to the application's needs.

*Figure 133* shows the behavior of the OCxREF signal when the ETRF input becomes high, for both values of the OCxCE enable bit. In this example, the timer TIMx is programmed in PWM mode.

**Figure 133. Clearing TIMx OCxREF**



### 14.3.12 Encoder interface mode

To select Encoder Interface mode write SMS='001 in the TIMx\_SMCR register if the counter is counting on TI2 edges only, SMS=010 if it is counting on TI1 edges only and SMS=011 if it is counting on both TI1 and TI2 edges.

Select the TI1 and TI2 polarity by programming the CC1P and CC2P bits in the TIMx\_CCER register. When needed, you can program the input filter as well.

The two inputs TI1 and TI2 are used to interface to an incremental encoder. Refer to [Table 83](#). The counter is clocked by each valid transition on TI1FP1 or TI2FP2 (TI1 and TI2 after input filter and polarity selection, TI1FP1=TI1 if not filtered and not inverted, TI2FP2=TI2 if not filtered and not inverted) assuming that it is enabled (CEN bit in TIMx\_CR1 register written to '1'). The sequence of transitions of the two inputs is evaluated and generates count pulses as well as the direction signal. Depending on the sequence the counter counts up or down, the DIR bit in the TIMx\_CR1 register is modified by hardware accordingly. The DIR bit is calculated at each transition on any input (TI1 or TI2), whatever the counter is counting on TI1 only, TI2 only or both TI1 and TI2.

Encoder interface mode acts simply as an external clock with direction selection. This means that the counter just counts continuously between 0 and the auto-reload value in the TIMx\_ARR register (0 to ARR or ARR down to 0 depending on the direction). So you must configure TIMx\_ARR before starting. In the same way, the capture, compare, prescaler, trigger output features continue to work as normal.

In this mode, the counter is modified automatically following the speed and the direction of the incremental encoder and its content, therefore, always represents the encoder's position. The count direction correspond to the rotation direction of the connected sensor. The table summarizes the possible combinations, assuming TI1 and TI2 don't switch at the same time.



**Table 83. Counting direction versus encoder signals**

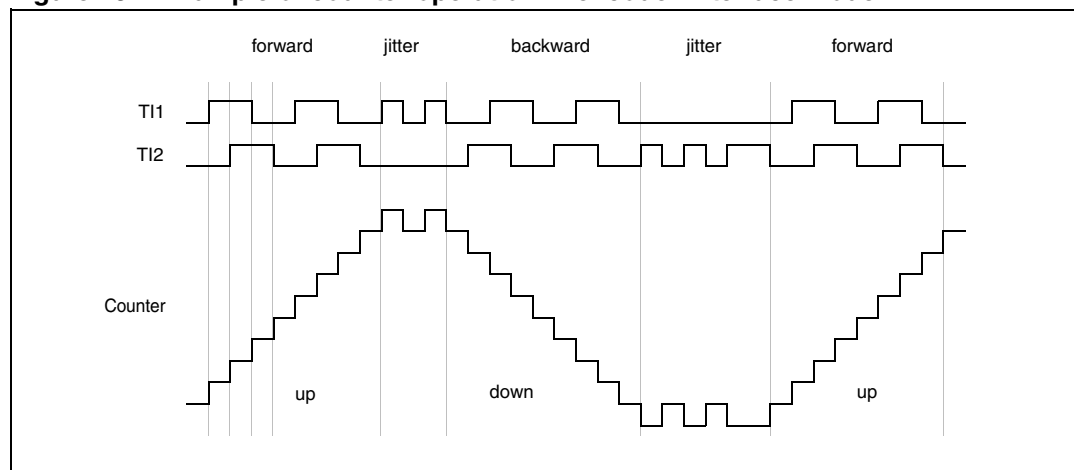
Active edge	Level on opposite signal (TI1FP1 for TI2, TI2FP2 for TI1)	TI1FP1 signal		TI2FP2 signal	
		Rising	Falling	Rising	Falling
Counting on TI1 only	High	Down	Up	No Count	No Count
	Low	Up	Down	No Count	No Count
Counting on TI2 only	High	No Count	No Count	Up	Down
	Low	No Count	No Count	Down	Up
Counting on TI1 and TI2	High	Down	Up	Up	Down
	Low	Up	Down	Down	Up

An external incremental encoder can be connected directly to the MCU without external interface logic. However, comparators are normally be used to convert the encoder’s differential outputs to digital signals. This greatly increases noise immunity. The third encoder output which indicate the mechanical zero position, may be connected to an external interrupt input and trigger a counter reset.

The *Figure 134* gives an example of counter operation, showing count signal generation and direction control. It also shows how input jitter is compensated where both edges are selected. This might occur if the sensor is positioned near to one of the switching points. For this example we assume that the configuration is the following:

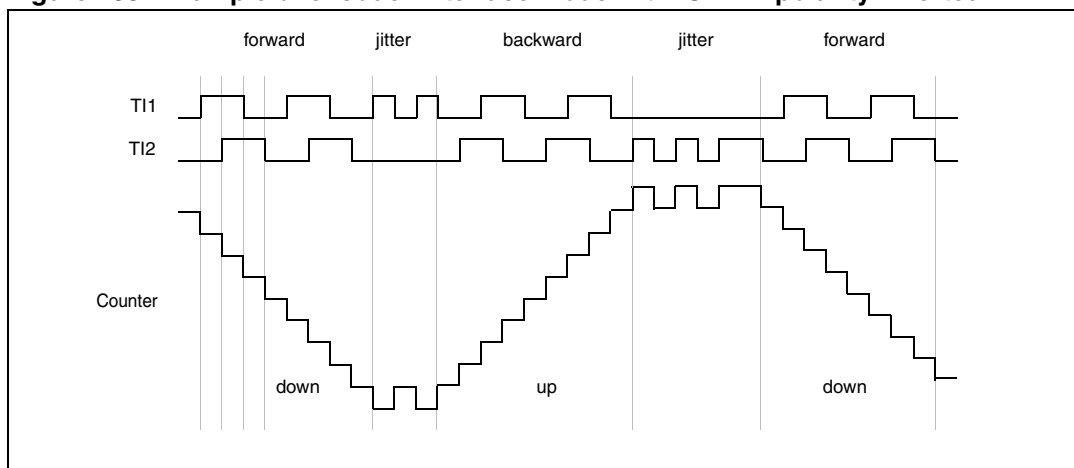
- CC1S= 01 (TIMx\_CCMR1 register, IC1FP1 mapped on TI1).
- CC2S= 01 (TIMx\_CCMR2 register, IC2FP2 mapped on TI2).
- CC1P=0 (TIMx\_CCER register, IC1FP1 non-inverted, IC1FP1=TI1).
- CC2P=0 (TIMx\_CCER register, IC2FP2 non-inverted, IC2FP2=TI2).
- SMS= 011 (TIMx\_SMCR register, both inputs are active on both rising and falling edges).
- CEN= 1 (TIMx\_CR1 register, Counter is enabled).

**Figure 134. Example of counter operation in encoder interface mode.**



*Figure 135* gives an example of counter behavior when IC1FP1 polarity is inverted (same configuration as above except CC1P=1).

**Figure 135. Example of encoder interface mode with IC1FP1 polarity inverted.**



The timer, when configured in Encoder Interface mode provides information on the sensor’s current position. You can obtain dynamic information (speed, acceleration, deceleration) by measuring the period between two encoder events using a second timer configured in capture mode. The output of the encoder which indicates the mechanical zero can be used for this purpose. Depending on the time between two events, the counter can also be read at regular times. You can do this by latching the counter value into a third input capture register if available (then the capture signal must be periodic and can be generated by another timer). when available, it is also possible to read its value through a DMA request generated by a Real-Time clock.

### 14.3.13 Timer input XOR function

The TI1S bit in the TIM1\_CR2 register, allows the input filter of channel 1 to be connected to the output of a XOR gate, combining the three input pins TIMx\_CH1 to TIMx\_CH3.

The XOR output can be used with all the timer input functions such as trigger or input capture.

An example of this feature used to interface Hall sensors is given in [Section 13.3.18 on page 304](#).

### 14.3.14 Timers and external trigger synchronization

The TIMx Timers can be synchronized with an external trigger in several modes: Reset mode, Gated mode and Trigger mode.

#### Slave mode: Reset mode

The counter and its prescaler can be reinitialized in response to an event on a trigger input. Moreover, if the URS bit from the TIMx\_CR1 register is low, an update event UEV is generated. Then all the preloaded registers (TIMx\_ARR, TIMx\_CCRx) are updated.

In the following example, the upcounter is cleared in response to a rising edge on TI1 input:

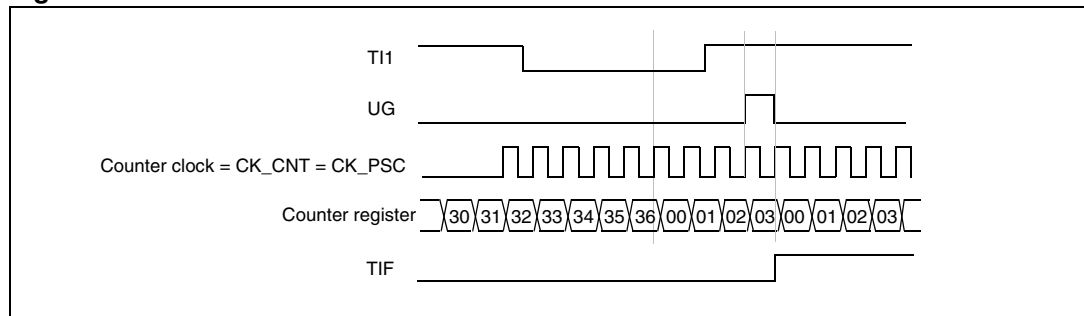
- Configure the channel 1 to detect rising edges on TI1. Configure the input filter duration (in this example, we don’t need any filter, so we keep IC1F=0000). The capture prescaler is not used for triggering, so you don’t need to configure it. The CC1S bits select the input capture source only, CC1S = 01 in the TIMx\_CCMR1 register. Write CC1P=0 in TIMx\_CCER register to validate the polarity (and detect rising edges only).

- Configure the timer in reset mode by writing SMS=100 in TIMx\_SMCR register. Select TI1 as the input source by writing TS=101 in TIMx\_SMCR register.
- Start the counter by writing CEN=1 in the TIMx\_CR1 register.

The counter starts counting on the internal clock, then behaves normally until TI1 rising edge. When TI1 rises, the counter is cleared and restarts from 0. In the meantime, the trigger flag is set (TIF bit in the TIMx\_SR register) and an interrupt request, or a DMA request can be sent if enabled (depending on the TIE and TDE bits in TIMx\_DIER register).

The following figure shows this behavior when the auto-reload register TIMx\_ARR=0x36. The delay between the rising edge on TI1 and the actual reset of the counter is due to the resynchronization circuit on TI1 input.

**Figure 136. Control circuit in reset mode**



**Slave mode: Gated mode**

The counter can be enabled depending on the level of a selected input.

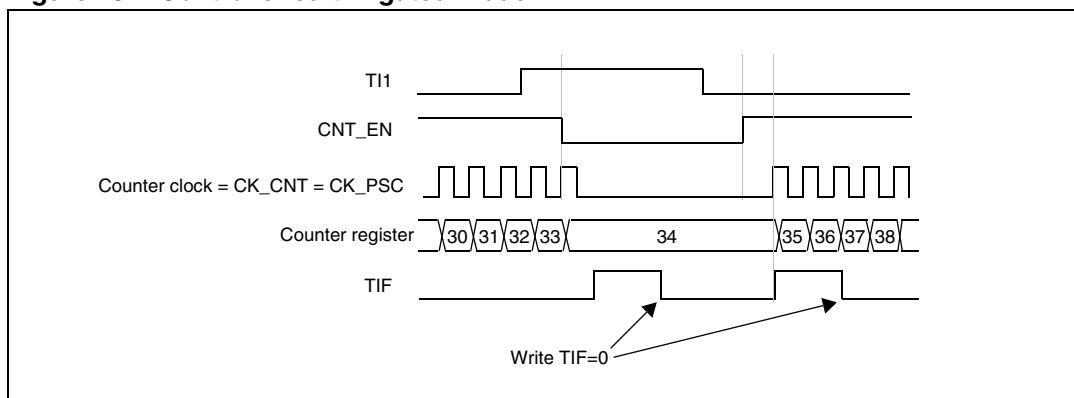
In the following example, the upcounter counts only when TI1 input is low:

- Configure the channel 1 to detect low levels on TI1. Configure the input filter duration (in this example, we don't need any filter, so we keep IC1F=0000). The capture prescaler is not used for triggering, so you don't need to configure it. The CC1S bits select the input capture source only, CC1S=01 in TIMx\_CCMR1 register. Write CC1P=1 in TIMx\_CCER register to validate the polarity (and detect low level only).
- Configure the timer in gated mode by writing SMS=101 in TIMx\_SMCR register. Select TI1 as the input source by writing TS=101 in TIMx\_SMCR register.
- Enable the counter by writing CEN=1 in the TIMx\_CR1 register (in gated mode, the counter doesn't start if CEN=0, whatever is the trigger input level).

The counter starts counting on the internal clock as long as TI1 is low and stops as soon as TI1 becomes high. The TIF flag in the TIMx\_SR register is set both when the counter starts or stops.

The delay between the rising edge on TI1 and the actual stop of the counter is due to the resynchronization circuit on TI1 input.

**Figure 137. Control circuit in gated mode**



**Slave mode: Trigger mode**

The counter can start in response to an event on a selected input.

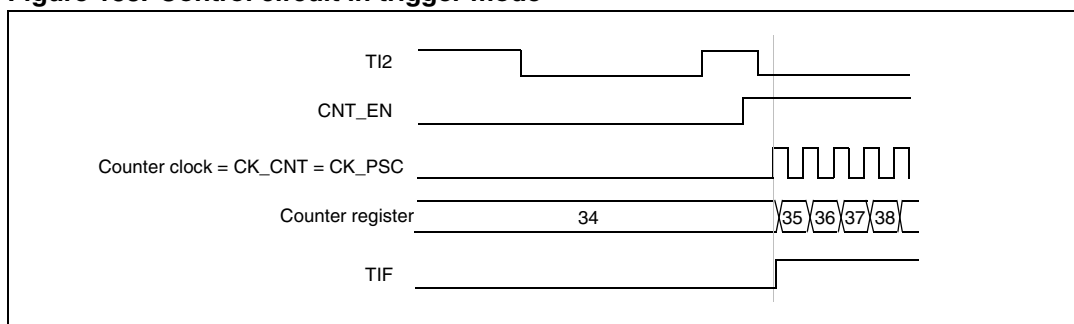
In the following example, the upcounter starts in response to a rising edge on TI2 input:

- Configure the channel 2 to detect rising edges on TI2. Configure the input filter duration (in this example, we don't need any filter, so we keep IC2F=0000). The capture prescaler is not used for triggering, so you don't need to configure it. CC2S bits are selecting the input capture source only, CC2S=01 in TIMx\_CCMR1 register. Write CC2P=1 in TIMx\_CCER register to validate the polarity (and detect low level only).
- Configure the timer in trigger mode by writing SMS=110 in TIMx\_SMCR register. Select TI2 as the input source by writing TS=110 in TIMx\_SMCR register.

When a rising edge occurs on TI2, the counter starts counting on the internal clock and the TIF flag is set.

The delay between the rising edge on TI2 and the actual start of the counter is due to the resynchronization circuit on TI2 input.

**Figure 138. Control circuit in trigger mode**



**Slave mode: External Clock mode 2 + trigger mode**

The external clock mode 2 can be used in addition to another slave mode (except external clock mode 1 and encoder mode). In this case, the ETR signal is used as external clock input, and another input can be selected as trigger input when operating in reset mode, gated mode or trigger mode. It is recommended not to select ETR as TRGI through the TS bits of TIMx\_SMCR register.

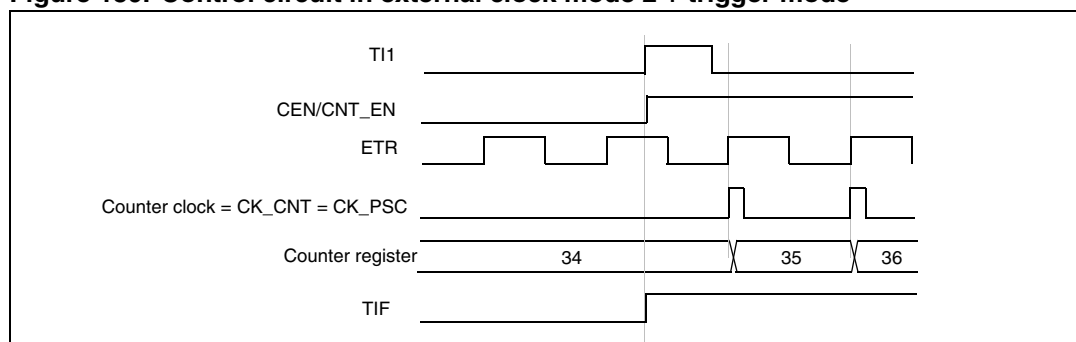
In the following example, the upcounter is incremented at each rising edge of the ETR signal as soon as a rising edge of TI1 occurs:

1. Configure the external trigger input circuit by programming the TIMx\_SMCR register as follows:
  - ETF = 0000: no filter
  - ETPS=00: prescaler disabled
  - ETP=0: detection of rising edges on ETR and ECE=1 to enable the external clock mode 2.
2. Configure the channel 1 as follows, to detect rising edges on TI:
  - IC1F=0000: no filter.
  - The capture prescaler is not used for triggering and does not need to be configured.
  - CC1S=01 in TIMx\_CCMR1 register to select only the input capture source
  - CC1P=0 in TIMx\_CCER register to validate the polarity (and detect rising edge only).
3. Configure the timer in trigger mode by writing SMS=110 in TIMx\_SMCR register. Select TI1 as the input source by writing TS=101 in TIMx\_SMCR register.

A rising edge on TI1 enables the counter and sets the TIF flag. The counter then counts on ETR rising edges.

The delay between the rising edge of the ETR signal and the actual reset of the counter is due to the resynchronization circuit on ETRP input.

**Figure 139. Control circuit in external clock mode 2 + trigger mode**



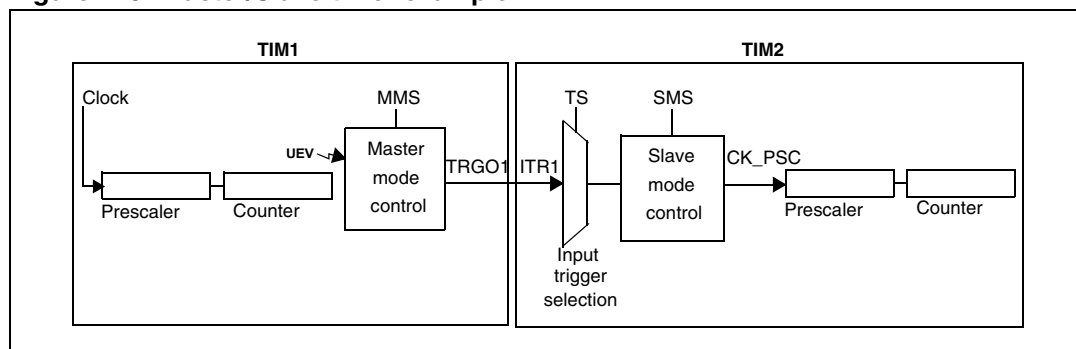
### 14.3.15 Timer synchronization

The TIMx timers are linked together internally for timer synchronization or chaining. When one Timer is configured in Master Mode, it can reset, start, stop or clock the counter of another Timer configured in Slave Mode.

The following figure presents an overview of the trigger selection and the master mode selection blocks.

### Using one timer as prescaler for another

Figure 140. Master/Slave timer example



For example, you can configure Timer 1 to act as a prescaler for Timer 2. Refer to [Figure 140](#). To do this:

- Configure Timer 1 in master mode so that it outputs a periodic trigger signal on each update event UEV. If you write MMS=010 in the TIM1\_CR2 register, a rising edge is output on TRGO1 each time an update event is generated.
- To connect the TRGO1 output of Timer 1 to Timer 2, Timer 2 must be configured in slave mode using ITR1 as internal trigger. You select this through the TS bits in the TIM2\_SMCR register (writing TS=000).
- Then you put the slave mode controller in external clock mode 1 (write SMS=111 in the TIM2\_SMCR register). This causes Timer 2 to be clocked by the rising edge of the periodic Timer 1 trigger signal (which correspond to the timer 1 counter overflow).
- Finally both timers must be enabled by setting their respective CEN bits (TIMx\_CR1 register).

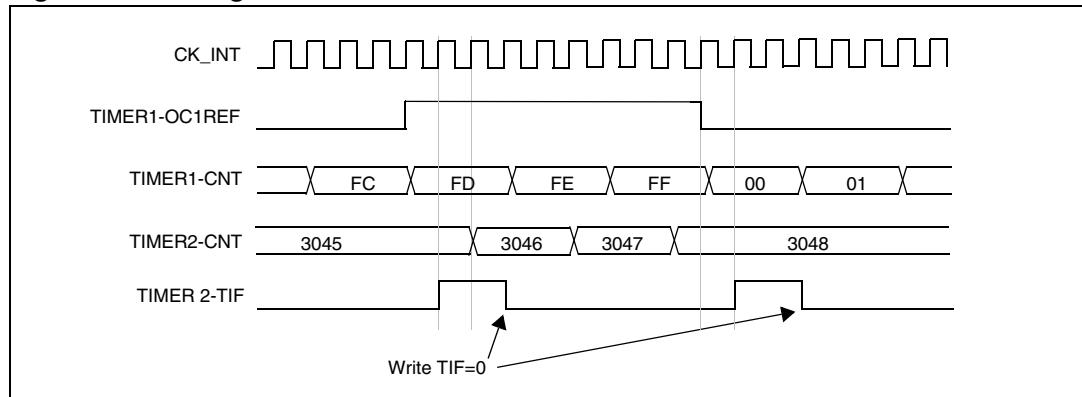
*Note:* If OCx is selected on Timer 1 as trigger output (MMS=1xx), its rising edge is used to clock the counter of timer 2.

### Using one timer to enable another timer

In this example, we control the enable of Timer 2 with the output compare 1 of Timer 1. Refer to [Figure 140](#) for connections. Timer 2 counts on the divided internal clock only when OC1REF of Timer 1 is high. Both counter clock frequencies are divided by 3 by the prescaler compared to CK\_INT ( $f_{CK\_CNT} = f_{CK\_INT}/3$ ).

- Configure Timer 1 master mode to send its Output Compare 1 Reference (OC1REF) signal as trigger output (MMS=100 in the TIM1\_CR2 register).
- Configure the Timer 1 OC1REF waveform (TIM1\_CCMR1 register).
- Configure Timer 2 to get the input trigger from Timer 1 (TS=000 in the TIM2\_SMCR register).
- Configure Timer 2 in gated mode (SMS=101 in TIM2\_SMCR register).
- Enable Timer 2 by writing '1 in the CEN bit (TIM2\_CR1 register).
- Start Timer 1 by writing '1 in the CEN bit (TIM1\_CR1 register).

*Note:* The counter 2 clock is not synchronized with counter 1, this mode only affects the Timer 2 counter enable signal.

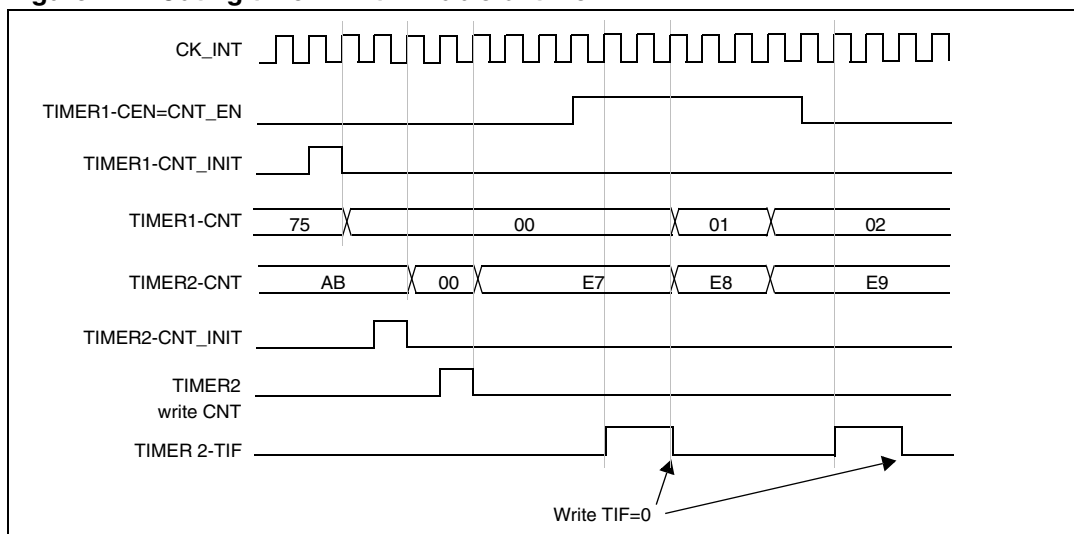
**Figure 141. Gating timer 2 with OC1REF of timer 1**

In the example in [Figure 141](#), the Timer 2 counter and prescaler are not initialized before being started. So they start counting from their current value. It is possible to start from a given value by resetting both timers before starting Timer 1. You can then write any value you want in the timer counters. The timers can easily be reset by software using the UG bit in the TIMx\_EGR registers.

In the next example, we synchronize Timer 1 and Timer 2. Timer 1 is the master and starts from 0. Timer 2 is the slave and starts from 0xE7. The prescaler ratio is the same for both timers. Timer 2 stops when Timer 1 is disabled by writing '0' to the CEN bit in the TIM1\_CR1 register:

- Configure Timer 1 master mode to send its Output Compare 1 Reference (OC1REF) signal as trigger output (MMS=100 in the TIM1\_CR2 register).
- Configure the Timer 1 OC1REF waveform (TIM1\_CCMR1 register).
- Configure Timer 2 to get the input trigger from Timer 1 (TS=000 in the TIM2\_SMCR register).
- Configure Timer 2 in gated mode (SMS=101 in TIM2\_SMCR register).
- Reset Timer 1 by writing '1' in UG bit (TIM1\_EGR register).
- Reset Timer 2 by writing '1' in UG bit (TIM2\_EGR register).
- Initialize Timer 2 to 0xE7 by writing '0xE7' in the timer 2 counter (TIM2\_CNT).
- Enable Timer 2 by writing '1' in the CEN bit (TIM2\_CR1 register).
- Start Timer 1 by writing '1' in the CEN bit (TIM1\_CR1 register).
- Stop Timer 1 by writing '0' in the CEN bit (TIM1\_CR1 register).

**Figure 142. Gating timer 2 with Enable of timer 1**

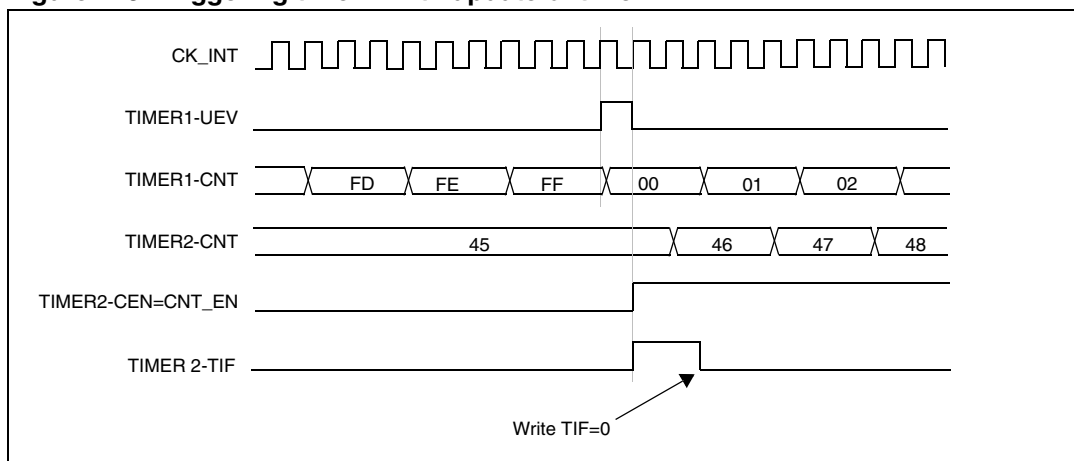


**Using one timer to start another timer**

In this example, we set the enable of Timer 2 with the update event of Timer 1. Refer to [Figure 140](#) for connections. Timer 2 starts counting from its current value (which can be non-zero) on the divided internal clock as soon as the update event is generated by Timer 1. When Timer 2 receives the trigger signal its CEN bit is automatically set and the counter counts until we write '0 to the CEN bit in the TIM2\_CR1 register. Both counter clock frequencies are divided by 3 by the prescaler compared to CK\_INT ( $f_{CK\_CNT} = f_{CK\_INT}/3$ ).

- Configure Timer 1 master mode to send its Update Event (UEV) as trigger output (MMS=010 in the TIM1\_CR2 register).
- Configure the Timer 1 period (TIM1\_ARR registers).
- Configure Timer 2 to get the input trigger from Timer 1 (TS=000 in the TIM2\_SMCR register).
- Configure Timer 2 in trigger mode (SMS=110 in TIM2\_SMCR register).
- Start Timer 1 by writing '1 in the CEN bit (TIM1\_CR1 register).

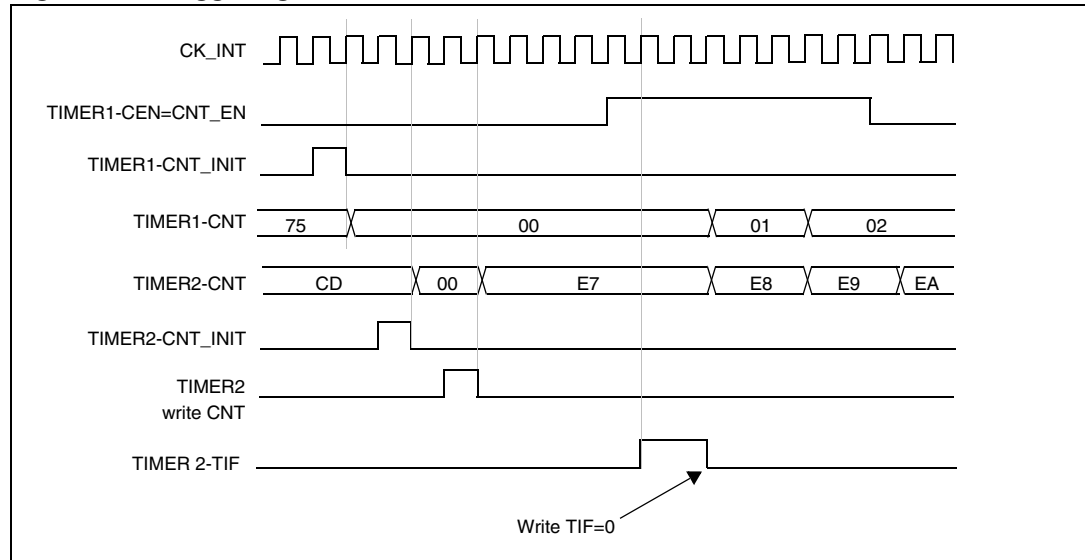
**Figure 143. Triggering timer 2 with update of timer 1**





As in the previous example, you can initialize both counters before starting counting. [Figure 144](#) shows the behavior with the same configuration as in [Figure 143](#) but in trigger mode instead of gated mode (SMS=110 in the TIM2\_SMCR register).

**Figure 144. Triggering timer 2 with Enable of timer 1**



### Using one timer as prescaler for another timer

For example, you can configure Timer 1 to act as a prescaler for Timer 2. Refer to [Figure 140](#) for connections. To do this:

- Configure Timer 1 master mode to send its Update Event (UEV) as trigger output (MMS=010 in the TIM1\_CR2 register). then it outputs a periodic signal on each counter overflow.
- Configure the Timer 1 period (TIM1\_ARR registers).
- Configure Timer 2 to get the input trigger from Timer 1 (TS=000 in the TIM2\_SMCR register).
- Configure Timer 2 in external clock mode 1 (SMS=111 in TIM2\_SMCR register).
- Start Timer 2 by writing '1 in the CEN bit (TIM2\_CR1 register).
- Start Timer 1 by writing '1 in the CEN bit (TIM1\_CR1 register).

### Starting 2 timers synchronously in response to an external trigger

In this example, we set the enable of timer 1 when its TI1 input rises, and the enable of Timer 2 with the enable of Timer 1. Refer to [Figure 140](#) for connections. To ensure the

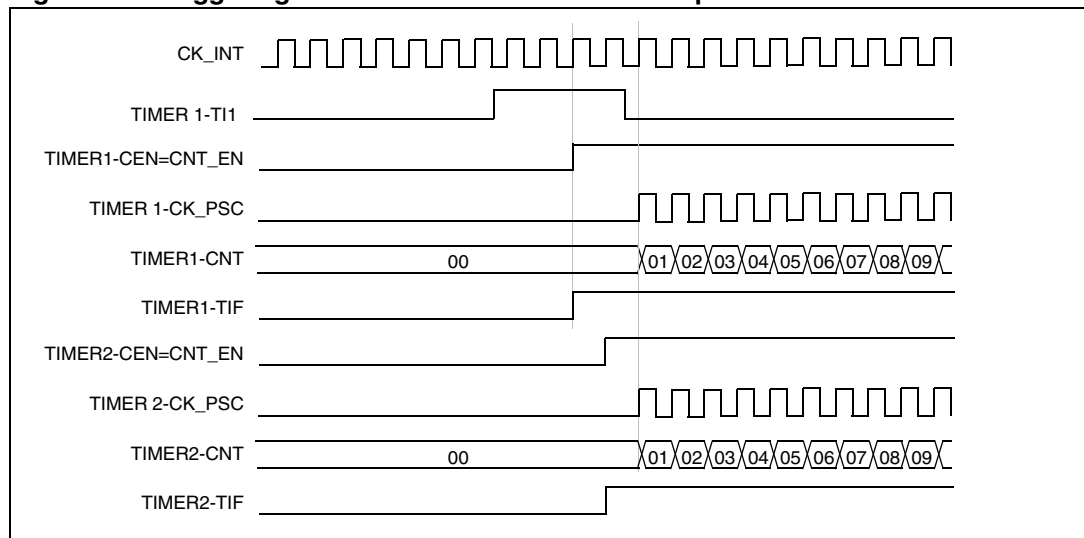
counters are aligned, Timer 1 must be configured in Master/Slave mode (slave with respect to TI1, master with respect to Timer 2):

- Configure Timer 1 master mode to send its Enable as trigger output (MMS=001 in the TIM1\_CR2 register).
- Configure Timer 1 slave mode to get the input trigger from TI1 (TS=100 in the TIM1\_SMCR register).
- Configure Timer 1 in trigger mode (SMS=110 in the TIM1\_SMCR register).
- Configure the Timer 1 in Master/Slave mode by writing MSM=1 (TIM1\_SMCR register).
- Configure Timer 2 to get the input trigger from Timer 1 (TS=000 in the TIM2\_SMCR register).
- Configure Timer 2 in trigger mode (SMS=110 in the TIM2\_SMCR register).

When a rising edge occurs on TI1 (Timer 1), both counters starts counting synchronously on the internal clock and both TIF flags are set.

*Note:* In this example both timers are initialized before starting (by setting their respective UG bits). Both counters starts from 0, but you can easily insert an offset between them by writing any of the counter registers (TIMx\_CNT). You can see that the master/slave mode insert a delay between CNT\_EN and CK\_PSC on timer 1.

**Figure 145. Triggering timer 1 and 2 with timer 1 TI1 input**



### 14.3.16 Debug mode

When the microcontroller enters debug mode (Cortex-M3 core - halted), the TIMx counter either continues to work normally or stops, depending on DBG\_TIMx\_STOP configuration bit in DBGMCU module. For more details, refer to [Section 30.16.2: Debug support for timers, watchdog, bxCAN and I2C](#).

## 14.4 TIMx2 to TIM5 registers

Refer to [Section 1.1 on page 40](#) for a list of abbreviations used in register descriptions.

The peripheral registers can be accessed by half-words (16-bit) or words (32-bit).

### 14.4.1 TIMx control register 1 (TIMx\_CR1)

Address offset: 0x00

Reset value: 0x0000

15	14	13	12	11	10	9	8	7	6	5	4	3	2	1	0
Reserved						CKD[1:0]		ARPE	CMS		DIR	OPM	URS	UDIS	CEN
						rw	rw	rw	rw	rw	rw	rw	rw	rw	rw

Bits 15:10 Reserved, always read as 0

Bits 9:8 **CKD**: Clock division

This bit-field indicates the division ratio between the timer clock (CK\_INT) frequency and sampling clock used by the digital filters (ETR, TIX),

- 00:  $t_{DTS} = t_{CK\_INT}$
- 01:  $t_{DTS} = 2 \times t_{CK\_INT}$
- 10:  $t_{DTS} = 4 \times t_{CK\_INT}$
- 11: Reserved

Bit 7 **ARPE**: Auto-reload preload enable

- 0: TIMx\_ARR register is not buffered
- 1: TIMx\_ARR register is buffered

Bits 6:5 **CMS**: Center-aligned mode selection

00: Edge-aligned mode. The counter counts up or down depending on the direction bit (DIR).

01: Center-aligned mode 1. The counter counts up and down alternatively. Output compare interrupt flags of channels configured in output (CCxS=00 in TIMx\_CCMRx register) are set only when the counter is counting down.

10: Center-aligned mode 2. The counter counts up and down alternatively. Output compare interrupt flags of channels configured in output (CCxS=00 in TIMx\_CCMRx register) are set only when the counter is counting up.

11: Center-aligned mode 3. The counter counts up and down alternatively. Output compare interrupt flags of channels configured in output (CCxS=00 in TIMx\_CCMRx register) are set both when the counter is counting up or down.

*Note: It is not allowed to switch from edge-aligned mode to center-aligned mode as long as the counter is enabled (CEN=1)*

Bit 4 **DIR**: Direction

- 0: Counter used as upcounter
- 1: Counter used as downcounter

*Note: This bit is read only when the timer is configured in Center-aligned mode or Encoder mode.*

Bit 3 **OPM**: One-pulse mode

- 0: Counter is not stopped at update event
- 1: Counter stops counting at the next update event (clearing the bit CEN)

Bit 2 **URS**: Update request source

This bit is set and cleared by software to select the UEV event sources.

0: Any of the following events generate an update interrupt or DMA request if enabled.

These events can be:

- Counter overflow/underflow
- Setting the UG bit
- Update generation through the slave mode controller

1: Only counter overflow/underflow generates an update interrupt or DMA request if enabled.

Bit 1 **UDIS**: Update disable

This bit is set and cleared by software to enable/disable UEV event generation.

0: UEV enabled. The Update (UEV) event is generated by one of the following events:

- Counter overflow/underflow
- Setting the UG bit
- Update generation through the slave mode controller

Buffered registers are then loaded with their preload values.

1: UEV disabled. The Update event is not generated, shadow registers keep their value (ARR, PSC, CCRx). However the counter and the prescaler are reinitialized if the UG bit is set or if a hardware reset is received from the slave mode controller.

Bit 0 **CEN**: Counter enable

0: Counter disabled

1: Counter enabled

*Note: External clock, gated mode and encoder mode can work only if the CEN bit has been previously set by software. However trigger mode can set the CEN bit automatically by hardware.*

CEN is cleared automatically in one-pulse mode, when an update event occurs.

### 14.4.2 TIMx control register 2 (TIMx\_CR2)

Address offset: 0x04

Reset value: 0x0000

15	14	13	12	11	10	9	8	7	6	5	4	3	2	1	0	
Reserved								T11S	MMS[2:0]			CCDS	Reserved			
								rw	rw	rw	rw	rw				

Bits 15:8 Reserved, always read as 0.

Bit 7 **T11S**: TI1 selection

0: The TIMx\_CH1 pin is connected to TI1 input

1: The TIMx\_CH1, CH2 and CH3 pins are connected to the TI1 input (XOR combination)

See also [Section 13.3.18: Interfacing with Hall sensors on page 304](#)

Bits 6:4 **MMS**: Master mode selection

These bits allow to select the information to be sent in master mode to slave timers for synchronization (TRGO). The combination is as follows:

000: **Reset** - the UG bit from the TIMx\_EGR register is used as trigger output (TRGO). If the reset is generated by the trigger input (slave mode controller configured in reset mode) then the signal on TRGO is delayed compared to the actual reset.

001: **Enable** - the Counter enable signal, CNT\_EN, is used as trigger output (TRGO). It is useful to start several timers at the same time or to control a window in which a slave timer is enabled. The Counter Enable signal is generated by a logic OR between CEN control bit and the trigger input when configured in gated mode.

When the Counter Enable signal is controlled by the trigger input, there is a delay on TRGO, except if the master/slave mode is selected (see the MSM bit description in TIMx\_SMCR register).

010: **Update** - The update event is selected as trigger output (TRGO). For instance a master timer can then be used as a prescaler for a slave timer.

011: **Compare Pulse** - The trigger output send a positive pulse when the CC1IF flag is to be set (even if it was already high), as soon as a capture or a compare match occurred. (TRGO)

100: **Compare** - OC1REF signal is used as trigger output (TRGO)

101: **Compare** - OC2REF signal is used as trigger output (TRGO)

110: **Compare** - OC3REF signal is used as trigger output (TRGO)

111: **Compare** - OC4REF signal is used as trigger output (TRGO)

Bit 3 **CCDS**: Capture/compare DMA selection

0: CCx DMA request sent when CCx event occurs

1: CCx DMA requests sent when update event occurs

Bits 2:0 Reserved, always read as 0

### 14.4.3 TIMx slave mode control register (TIMx\_SMCR)

Address offset: 0x08

Reset value: 0x0000

15	14	13	12	11	10	9	8	7	6	5	4	3	2	1	0
ETP	ECE	ETPS[1:0]		ETF[3:0]				MSM	TS[2:0]			Res.	SMS[2:0]		
rw	rw	rw	rw	rw	rw	rw	rw	rw	rw	rw	rw		rw	rw	rw

Bit 15 **ETP**: External trigger polarity

This bit selects whether ETR or  $\overline{ETR}$  is used for trigger operations

0: ETR is non-inverted, active at high level or rising edge

1: ETR is inverted, active at low level or falling edge

Bit 14 **ECE**: External clock enable

This bit enables External clock mode 2.

0: External clock mode 2 disabled

1: External clock mode 2 enabled. The counter is clocked by any active edge on the ETRF signal.

**1:** Setting the ECE bit has the same effect as selecting external clock mode 1 with TRGI connected to ETRF (SMS=111 and TS=111).

**2:** It is possible to simultaneously use external clock mode 2 with the following slave modes: reset mode, gated mode and trigger mode. Nevertheless, TRGI must not be connected to ETRF in this case (TS bits must not be 111).

**3:** If external clock mode 1 and external clock mode 2 are enabled at the same time, the external clock input is ETRF.

Bits 13:12 **ETPS**: External trigger prescaler

External trigger signal ETRP frequency must be at most 1/4 of CK\_INT frequency. A prescaler can be enabled to reduce ETRP frequency. It is useful when inputting fast external clocks.

- 00: Prescaler OFF
- 01: ETRP frequency divided by 2
- 10: ETRP frequency divided by 4
- 11: ETRP frequency divided by 8

Bits 11:8 **ETF[3:0]**: External trigger filter

This bit-field then defines the frequency used to sample ETRP signal and the length of the digital filter applied to ETRP. The digital filter is made of an event counter in which N events are needed to validate a transition on the output:

- 0000: No filter, sampling is done at  $f_{DTS}$
- 0001:  $f_{SAMPLING}=f_{CK\_INT}$ , N=2
- 0010:  $f_{SAMPLING}=f_{CK\_INT}$ , N=4
- 0011:  $f_{SAMPLING}=f_{CK\_INT}$ , N=8
- 0100:  $f_{SAMPLING}=f_{DTS}/2$ , N=6
- 0101:  $f_{SAMPLING}=f_{DTS}/2$ , N=8
- 0110:  $f_{SAMPLING}=f_{DTS}/4$ , N=6
- 0111:  $f_{SAMPLING}=f_{DTS}/4$ , N=8
- 1000:  $f_{SAMPLING}=f_{DTS}/8$ , N=6
- 1001:  $f_{SAMPLING}=f_{DTS}/8$ , N=8
- 1010:  $f_{SAMPLING}=f_{DTS}/16$ , N=5
- 1011:  $f_{SAMPLING}=f_{DTS}/16$ , N=6
- 1100:  $f_{SAMPLING}=f_{DTS}/16$ , N=8
- 1101:  $f_{SAMPLING}=f_{DTS}/32$ , N=5
- 1110:  $f_{SAMPLING}=f_{DTS}/32$ , N=6
- 1111:  $f_{SAMPLING}=f_{DTS}/32$ , N=8

Bit 7 **MSM**: Master/Slave mode

- 0: No action
- 1: The effect of an event on the trigger input (TRGI) is delayed to allow a perfect synchronization between the current timer and its slaves (through TRGO). It is useful if we want to synchronize several timers on a single external event.

Bits 6:4 **TS**: Trigger selection

This bit-field selects the trigger input to be used to synchronize the counter.

- 000: Internal Trigger 0 (ITR0).
- 001: Internal Trigger 1 (ITR1).
- 010: Internal Trigger 2 (ITR2).
- 011: Internal Trigger 3 (ITR3).
- 100: TI1 Edge Detector (TI1F\_ED)
- 101: Filtered Timer Input 1 (TI1FP1)
- 110: Filtered Timer Input 2 (TI2FP2)
- 111: External Trigger input (ETRF)

See [Table 84: TIMx Internal trigger connection on page 375](#) for more details on ITRx meaning for each Timer.

*Note: These bits must be changed only when they are not used (e.g. when SMS=000) to avoid wrong edge detections at the transition.*

Bit 3 Reserved, always read as 0.

Bits 2:0 **SMS**: Slave mode selection

When external signals are selected the active edge of the trigger signal (TRGI) is linked to the polarity selected on the external input (see Input Control register and Control Register description).

000: Slave mode disabled - if CEN = '1 then the prescaler is clocked directly by the internal clock.

001: Encoder mode 1 - Counter counts up/down on TI2FP2 edge depending on TI1FP1 level.

010: Encoder mode 2 - Counter counts up/down on TI1FP1 edge depending on TI2FP2 level.

011: Encoder mode 3 - Counter counts up/down on both TI1FP1 and TI2FP2 edges depending on the level of the other input.

100: Reset Mode - Rising edge of the selected trigger input (TRGI) reinitializes the counter and generates an update of the registers.

101: Gated Mode - The counter clock is enabled when the trigger input (TRGI) is high. The counter stops (but is not reset) as soon as the trigger becomes low. Both start and stop of the counter are controlled.

110: Trigger Mode - The counter starts at a rising edge of the trigger TRGI (but it is not reset). Only the start of the counter is controlled.

111: External Clock Mode 1 - Rising edges of the selected trigger (TRGI) clock the counter.

*Note: The gated mode must not be used if TI1F\_ED is selected as the trigger input (TS=100). Indeed, TI1F\_ED outputs 1 pulse for each transition on TI1F, whereas the gated mode checks the level of the trigger signal.*

**Table 84. TIMx Internal trigger connection<sup>(1)</sup>**

Slave TIM	ITR0 (TS = 000)	ITR1 (TS = 001)	ITR2 (TS = 010)	ITR3 (TS = 011)
<b>TIM2</b>	TIM1	TIM8	TIM3	TIM4
<b>TIM3</b>	TIM1	TIM2	TIM5	TIM4
<b>TIM4</b>	TIM1	TIM2	TIM3	TIM8
<b>TIM5</b>	TIM2	TIM3	TIM4	TIM8

1. When a timer is not present in the product, the corresponding trigger ITRx is not available.

### 14.4.4 TIMx DMA/Interrupt enable register (TIMx\_DIER)

Address offset: 0x0C

Reset value: 0x0000

15	14	13	12	11	10	9	8	7	6	5	4	3	2	1	0
Res.	TDE	Res	CC4DE	CC3DE	CC2DE	CC1DE	UDE	Res.	TIE	Res	CC4IE	CC3IE	CC2IE	CC1IE	UIE
	rw		rw	rw	rw	rw	rw		rw		rw	rw	rw	rw	rw

- Bit 15 Reserved, always read as 0.
- Bit 14 **TDE**: Trigger DMA request enable  
 0: Trigger DMA request disabled.  
 1: Trigger DMA request enabled.
- Bit 13 Reserved, always read as 0
- Bit 12 **CC4DE**: Capture/Compare 4 DMA request enable  
 0: CC4 DMA request disabled.  
 1: CC4 DMA request enabled.
- Bit 11 **CC3DE**: Capture/Compare 3 DMA request enable  
 0: CC3 DMA request disabled.  
 1: CC3 DMA request enabled.
- Bit 10 **CC2DE**: Capture/Compare 2 DMA request enable  
 0: CC2 DMA request disabled.  
 1: CC2 DMA request enabled.
- Bit 9 **CC1DE**: Capture/Compare 1 DMA request enable  
 0: CC1 DMA request disabled.  
 1: CC1 DMA request enabled.
- Bit 8 **UDE**: Update DMA request enable  
 0: Update DMA request disabled.  
 1: Update DMA request enabled.
- Bit 7 Reserved, always read as 0.
- Bit 6 **TIE**: Trigger interrupt enable  
 0: Trigger interrupt disabled.  
 1: Trigger interrupt enabled.
- Bit 5 Reserved, always read as 0.
- Bit 4 **CC4IE**: Capture/Compare 4 interrupt enable  
 0: CC4 interrupt disabled.  
 1: CC4 interrupt enabled.
- Bit 3 **CC3IE**: Capture/Compare 3 interrupt enable  
 0: CC3 interrupt disabled.  
 1: CC3 interrupt enabled.



- Bit 2 **CC2IE**: Capture/Compare 2 interrupt enable  
 0: CC2 interrupt disabled.  
 1: CC2 interrupt enabled.
- Bit 1 **CC1IE**: Capture/Compare 1 interrupt enable  
 0: CC1 interrupt disabled.  
 1: CC1 interrupt enabled.
- Bit 0 **UIE**: Update interrupt enable  
 0: Update interrupt disabled.  
 1: Update interrupt enabled.

### 14.4.5 TIMx status register (TIMx\_SR)

Address offset: 0x10

Reset value: 0x0000

15	14	13	12	11	10	9	8	7	6	5	4	3	2	1	0		
Reserved				CC4OF	CC3OF	CC2OF	CC1OF	Reserved			TIF	Res	CC4IF	CC3IF	CC2IF	CC1IF	UIF
				rc_w0	rc_w0	rc_w0	rc_w0				rc_w0		rc_w0	rc_w0	rc_w0	rc_w0	rc_w0

- Bit 15:13 Reserved, always read as 0.
- Bit 12 **CC4OF**: Capture/Compare 4 overcapture flag  
refer to CC1OF description
- Bit 11 **CC3OF**: Capture/Compare 3 overcapture flag  
refer to CC1OF description
- Bit 10 **CC2OF**: Capture/compare 2 overcapture flag  
refer to CC1OF description
- Bit 9 **CC1OF**: Capture/Compare 1 overcapture flag  
 This flag is set by hardware only when the corresponding channel is configured in input capture mode. It is cleared by software by writing it to '0'.  
 0: No overcapture has been detected.  
 1: The counter value has been captured in TIMx\_CCR1 register while CC1IF flag was already set
- Bits 8:7 Reserved, always read as 0.
- Bit 6 **TIF**: Trigger interrupt flag  
 This flag is set by hardware on trigger event (active edge detected on TRGI input when the slave mode controller is enabled in all modes but gated mode, both edges in case gated mode is selected). It is cleared by software.  
 0: No trigger event occurred.  
 1: Trigger interrupt pending.
- Bit 5 Reserved, always read as 0
- Bit 4 **CC4IF**: Capture/Compare 4 interrupt flag  
refer to CC1IF description
- Bit 3 **CC3IF**: Capture/Compare 3 interrupt flag  
refer to CC1IF description
- Bit 2 **CC2IF**: Capture/Compare 2 interrupt flag  
refer to CC1IF description

- Bit 1 **CC1IF**: Capture/compare 1 interrupt flag  
**If channel CC1 is configured as output:**  
 This flag is set by hardware when the counter matches the compare value, with some exception in center-aligned mode (refer to the CMS bits in the TIMx\_CR1 register description). It is cleared by software.  
 0: No match.  
 1: The content of the counter TIMx\_CNT has matched the content of the TIMx\_CCR1 register.  
**If channel CC1 is configured as input:**  
 This bit is set by hardware on a capture. It is cleared by software or by reading the TIMx\_CCR1 register.  
 0: No input capture occurred.  
 1: The counter value has been captured in TIMx\_CCR1 register (An edge has been detected on IC1 which matches the selected polarity).
- Bit 0 **UIF**: Update interrupt flag  
 –This bit is set by hardware on an update event. It is cleared by software.  
 0: No update occurred.  
 1: Update interrupt pending. This bit is set by hardware when the registers are updated:  
 –At overflow or underflow regarding the repetition counter value (update if repetition counter = 0) and if the UDIS=0 in the TIMx\_CR1 register.  
 –When CNT is reinitialized by software using the UG bit in TIMx\_EGR register, if URS=0 and UDIS=0 in the TIMx\_CR1 register.  
 –When CNT is reinitialized by a trigger event (refer to the synchro control register description), if URS=0 and UDIS=0 in the TIMx\_CR1 register.

### 14.4.6 TIMx event generation register (TIMx\_EGR)

Address offset: 0x14

Reset value: 0x0000

15	14	13	12	11	10	9	8	7	6	5	4	3	2	1	0
Reserved									TG	Res.	CC4G	CC3G	CC2G	CC1G	UG
									w		w	w	w	w	

Bits 15:7 Reserved, always read as 0.

- Bit 6 **TG**: Trigger generation  
 This bit is set by software in order to generate an event, it is automatically cleared by hardware.  
 0: No action  
 1: The TIF flag is set in TIMx\_SR register. Related interrupt or DMA transfer can occur if enabled.
- Bit 5 Reserved, always read as 0.
- Bit 4 **CC4G**: Capture/compare 4 generation  
 refer to CC1G description
- Bit 3 **CC3G**: Capture/compare 3 generation  
 refer to CC1G description



- Bit 2 **CC2G**: Capture/compare 2 generation  
refer to CC1G description
- Bit 1 **CC1G**: Capture/compare 1 generation  
This bit is set by software in order to generate an event, it is automatically cleared by hardware.  
0: No action  
1: A capture/compare event is generated on channel 1:  
**If channel CC1 is configured as output:**  
CC1IF flag is set, Corresponding interrupt or DMA request is sent if enabled.  
**If channel CC1 is configured as input:**  
The current value of the counter is captured in TIMx\_CCR1 register. The CC1IF flag is set, the corresponding interrupt or DMA request is sent if enabled. The CC1OF flag is set if the CC1IF flag was already high.
- Bit 0 **UG**: Update generation  
This bit can be set by software, it is automatically cleared by hardware.  
0: No action  
1: Re-initialize the counter and generates an update of the registers. Note that the prescaler counter is cleared too (anyway the prescaler ratio is not affected). The counter is cleared if the center-aligned mode is selected or if DIR=0 (upcounting), else it takes the auto-reload value (TIMx\_ARR) if DIR=1 (downcounting).

### 14.4.7 TIMx capture/compare mode register 1 (TIMx\_CCMR1)

Address offset: 0x18

Reset value: 0x0000

The channels can be used in input (capture mode) or in output (compare mode). The direction of a channel is defined by configuring the corresponding CCxS bits. All the other bits of this register have a different function in input and in output mode. For a given bit, OCxx describes its function when the channel is configured in output, ICxx describes its function when the channel is configured in input. So you must take care that the same bit can have a different meaning for the input stage and for the output stage.

15	14	13	12	11	10	9	8	7	6	5	4	3	2	1	0
OC2CE	OC2M[2:0]			OC2PE	OC2FE	CC2S[1:0]		OC1CE	OC1M[2:0]			OC1PE	OC1FE	CC1S[1:0]	
IC2F[3:0]				IC2PSC[1:0]				IC1F[3:0]				IC1PSC[1:0]			
rw	rw	rw	rw	rw	rw	rw	rw	rw	rw	rw	rw	rw	rw	rw	rw

#### Output compare mode

- Bit 15 **OC2CE**: Output compare 2 clear enable
- Bits 14:12 **OC2M[2:0]**: Output compare 2 mode
- Bit 11 **OC2PE**: Output compare 2 preload enable
- Bit 10 **OC2FE**: Output compare 2 fast enable

Bits 9:8 **CC2S[1:0]**: Capture/Compare 2 selection

This bit-field defines the direction of the channel (input/output) as well as the used input.

00: CC2 channel is configured as output

01: CC2 channel is configured as input, IC2 is mapped on TI2

10: CC2 channel is configured as input, IC2 is mapped on TI1

11: CC2 channel is configured as input, IC2 is mapped on TRC. This mode is working only if an internal trigger input is selected through the TS bit (TIMx\_SMCR register)

*Note:* CC2S bits are writable only when the channel is OFF (CC2E = 0 in TIMx\_CCER).

Bit 7 **OC1CE**: Output compare 1 clear enable

OC1CE: Output Compare 1 Clear Enable

0: OC1Ref is not affected by the ETRF input

1: OC1Ref is cleared as soon as a High level is detected on ETRF input

Bits 6:4 **OC1M**: Output compare 1 mode

These bits define the behavior of the output reference signal OC1REF from which OC1 and OC1N are derived. OC1REF is active high whereas OC1 and OC1N active level depends on CC1P and CC1NP bits.

000: Frozen - The comparison between the output compare register TIMx\_CCR1 and the counter TIMx\_CNT has no effect on the outputs.(this mode is used to generate a timing base).

001: Set channel 1 to active level on match. OC1REF signal is forced high when the counter TIMx\_CNT matches the capture/compare register 1 (TIMx\_CCR1).

010: Set channel 1 to inactive level on match. OC1REF signal is forced low when the counter TIMx\_CNT matches the capture/compare register 1 (TIMx\_CCR1).

011: Toggle - OC1REF toggles when TIMx\_CNT=TIMx\_CCR1.

100: Force inactive level - OC1REF is forced low.

101: Force active level - OC1REF is forced high.

110: PWM mode 1 - In upcounting, channel 1 is active as long as TIMx\_CNT<TIMx\_CCR1 else inactive. In downcounting, channel 1 is inactive (OC1REF=0) as long as TIMx\_CNT>TIMx\_CCR1 else active (OC1REF=1).

111: PWM mode 2 - In upcounting, channel 1 is inactive as long as TIMx\_CNT<TIMx\_CCR1 else active. In downcounting, channel 1 is active as long as TIMx\_CNT>TIMx\_CCR1 else inactive.

*Note:* **1:** These bits can not be modified as long as LOCK level 3 has been programmed (LOCK bits in TIMx\_BDTR register) and CC1S=00 (the channel is configured in output).

**2:** In PWM mode 1 or 2, the OCREF level changes only when the result of the comparison changes or when the output compare mode switches from "frozen" mode to "PWM" mode.

Bit 3 **OC1PE**: Output compare 1 preload enable

0: Preload register on TIMx\_CCR1 disabled. TIMx\_CCR1 can be written at anytime, the new value is taken in account immediately.

1: Preload register on TIMx\_CCR1 enabled. Read/Write operations access the preload register. TIMx\_CCR1 preload value is loaded in the active register at each update event.

*Note:* **1:** These bits can not be modified as long as LOCK level 3 has been programmed (LOCK bits in TIMx\_BDTR register) and CC1S=00 (the channel is configured in output).

**2:** The PWM mode can be used without validating the preload register only in one-pulse mode (OPM bit set in TIMx\_CR1 register). Else the behavior is not guaranteed.

Bit 2 **OC1FE**: Output compare 1 fast enable

This bit is used to accelerate the effect of an event on the trigger in input on the CC output.  
0: CC1 behaves normally depending on counter and CCR1 values even when the trigger is ON. The minimum delay to activate CC1 output when an edge occurs on the trigger input is 5 clock cycles.

1: An active edge on the trigger input acts like a compare match on CC1 output. Then, OC is set to the compare level independently from the result of the comparison. Delay to sample the trigger input and to activate CC1 output is reduced to 3 clock cycles. OCFE acts only if the channel is configured in PWM1 or PWM2 mode.

Bits 1:0 **CC1S**: Capture/Compare 1 selection

This bit-field defines the direction of the channel (input/output) as well as the used input.

00: CC1 channel is configured as output.

01: CC1 channel is configured as input, IC1 is mapped on TI1.

10: CC1 channel is configured as input, IC1 is mapped on TI2.

11: CC1 channel is configured as input, IC1 is mapped on TRC. This mode is working only if an internal trigger input is selected through TS bit (TIMx\_SMCR register)

*Note: CC1S bits are writable only when the channel is OFF (CC1E = 0 in TIMx\_CCER).*

### Input capture mode

Bits 15:12 **IC2F**: Input capture 2 filter

Bits 11:10 **IC2PSC[1:0]**: Input capture 2 prescaler

Bits 9:8 **CC2S**: Capture/compare 2 selection

This bit-field defines the direction of the channel (input/output) as well as the used input.

00: CC2 channel is configured as output.

01: CC2 channel is configured as input, IC2 is mapped on TI2.

10: CC2 channel is configured as input, IC2 is mapped on TI1.

11: CC2 channel is configured as input, IC2 is mapped on TRC. This mode is working only if an internal trigger input is selected through TS bit (TIMx\_SMCR register)

*Note: CC2S bits are writable only when the channel is OFF (CC2E = 0 in TIMx\_CCER).*

Bits 7:4 **IC1F**: Input capture 1 filter

This bit-field defines the frequency used to sample TI1 input and the length of the digital filter applied to TI1. The digital filter is made of an event counter in which N events are needed to validate a transition on the output:

0000: No filter, sampling is done at  $f_{DTS}$

0001:  $f_{SAMPLING}=f_{CK\_INT}$ , N=2

0010:  $f_{SAMPLING}=f_{CK\_INT}$ , N=4

0011:  $f_{SAMPLING}=f_{CK\_INT}$ , N=8

0100:  $f_{SAMPLING}=f_{DTS}/2$ , N=6

0101:  $f_{SAMPLING}=f_{DTS}/2$ , N=8

0110:  $f_{SAMPLING}=f_{DTS}/4$ , N=6

0111:  $f_{SAMPLING}=f_{DTS}/4$ , N=8

1000:  $f_{SAMPLING}=f_{DTS}/8$ , N=6

1001:  $f_{SAMPLING}=f_{DTS}/8$ , N=8

1010:  $f_{SAMPLING}=f_{DTS}/16$ , N=5

1011:  $f_{SAMPLING}=f_{DTS}/16$ , N=6

1100:  $f_{SAMPLING}=f_{DTS}/16$ , N=8

1101:  $f_{SAMPLING}=f_{DTS}/32$ , N=5

1110:  $f_{SAMPLING}=f_{DTS}/32$ , N=6

1111:  $f_{SAMPLING}=f_{DTS}/32$ , N=8

*Note:* In current silicon revision,  $f_{DTS}$  is replaced in the formula by  $CK\_INT$  when  $ICx[F3:0]=1, 2$  or  $3$ .

Bits 3:2 **IC1PSC**: Input capture 1 prescaler

This bit-field defines the ratio of the prescaler acting on CC1 input (IC1).

The prescaler is reset as soon as  $CC1E=0$  (TIMx\_CCER register).

00: no prescaler, capture is done each time an edge is detected on the capture input

01: capture is done once every 2 events

10: capture is done once every 4 events

11: capture is done once every 8 events

Bits 1:0 **CC1S**: Capture/Compare 1 selection

This bit-field defines the direction of the channel (input/output) as well as the used input.

00: CC1 channel is configured as output

01: CC1 channel is configured as input, IC1 is mapped on TI1

10: CC1 channel is configured as input, IC1 is mapped on TI2

11: CC1 channel is configured as input, IC1 is mapped on TRC. This mode is working only if an internal trigger input is selected through TS bit (TIMx\_SMCR register)

*Note:* CC1S bits are writable only when the channel is OFF ( $CC1E = 0$  in TIMx\_CCER).

### 14.4.8 Capture/compare mode register 2 (TIMx\_CCMR2)

Address offset: 0x1C

Reset value: 0x0000

Refer to the above CCMR1 register description.

15	14	13	12	11	10	9	8	7	6	5	4	3	2	1	0
OC4CE	OC4M[2:0]			OC4PE	OC4FE	CC4S[1:0]		OC3CE	OC3M[2:0]			OC3PE	OC3FE	CC3S[1:0]	
IC4F[3:0]				IC4PSC[1:0]				IC3F[3:0]				IC3PSC[1:0]			
rw	rw	rw	rw	rw	rw	rw	rw	rw	rw	rw	rw	rw	rw	rw	rw

#### Output compare mode

Bit 15 **OC4CE**: Output compare 4 clear enable

Bits 14:12 **OC4M**: Output compare 4 mode

Bit 11 **OC4PE**: Output compare 4 preload enable

Bit 10 **OC4FE**: Output compare 4 fast enable

Bits 9:8 **CC4S**: Capture/Compare 4 selection

This bit-field defines the direction of the channel (input/output) as well as the used input.

00: CC4 channel is configured as output

01: CC4 channel is configured as input, IC4 is mapped on TI4

10: CC4 channel is configured as input, IC4 is mapped on TI3

11: CC4 channel is configured as input, IC4 is mapped on TRC. This mode is working only if an internal trigger input is selected through TS bit (TIMx\_SMCR register)

*Note: CC4S bits are writable only when the channel is OFF (CC4E = 0 in TIMx\_CCER).*

Bit 7 **OC3CE**: Output compare 3 clear enable

Bits 6:4 **OC3M**: Output compare 3 mode

Bit 3 **OC3PE**: Output compare 3 preload enable

Bit 2 **OC3FE**: Output compare 3 fast enable

Bits 1:0 **CC3S**: Capture/Compare 3 selection

This bit-field defines the direction of the channel (input/output) as well as the used input.

00: CC3 channel is configured as output

01: CC3 channel is configured as input, IC3 is mapped on TI3

10: CC3 channel is configured as input, IC3 is mapped on TI4

11: CC3 channel is configured as input, IC3 is mapped on TRC. This mode is working only if an internal trigger input is selected through TS bit (TIMx\_SMCR register)

*Note: CC3S bits are writable only when the channel is OFF (CC3E = 0 in TIMx\_CCER).*

### Input capture mode

Bits 15:12 **IC4F**: Input capture 4 filter

Bits 11:10 **IC4PSC**: Input capture 4 prescaler

Bits 9:8 **CC4S**: Capture/Compare 4 selection

This bit-field defines the direction of the channel (input/output) as well as the used input.

00: CC4 channel is configured as output

01: CC4 channel is configured as input, IC4 is mapped on TI4

10: CC4 channel is configured as input, IC4 is mapped on TI3

11: CC4 channel is configured as input, IC4 is mapped on TRC. This mode is working only if an internal trigger input is selected through TS bit (TIMx\_SMCR register)

*Note: CC4S bits are writable only when the channel is OFF (CC4E = 0 in TIMx\_CCER).*

Bits 7:4 **IC3F**: Input capture 3 filter

Bits 3:2 **IC3PSC**: Input capture 3 prescaler

Bits 1:0 **CC3S**: Capture/Compare 3 selection

This bit-field defines the direction of the channel (input/output) as well as the used input.

00: CC3 channel is configured as output

01: CC3 channel is configured as input, IC3 is mapped on TI3

10: CC3 channel is configured as input, IC3 is mapped on TI4

11: CC3 channel is configured as input, IC3 is mapped on TRC. This mode is working only if an internal trigger input is selected through TS bit (TIMx\_SMCR register)

*Note: CC3S bits are writable only when the channel is OFF (CC3E = 0 in TIMx\_CCER).*

### 14.4.9 TIMx capture/compare enable register (TIMx\_CCER)

Address offset: 0x20

Reset value: 0x0000

15	14	13	12	11	10	9	8	7	6	5	4	3	2	1	0		
Reserved		CC4P	CC4E	Reserved			CC3P	CC3E	Reserved			CC2P	CC2E	Reserved		CC1P	CC1E
		rw	rw				rw	rw				rw	rw			rw	rw

Bits 15:14 Reserved, always read as 0.

Bit 13 **CC4P**: Capture/Compare 4 output polarity refer to CC1P description

Bit 12 **CC4E**: Capture/Compare 4 output enable refer to CC1E description

Bits 11:10 Reserved, always read as 0.

Bit 9 **CC3P**: Capture/Compare 3 output polarity refer to CC1P description

Bit 8 **CC3E**: Capture/Compare 3 output enable refer to CC1E description

Bits 7:6 Reserved, always read as 0.

Bit 5 **CC2P**: Capture/Compare 2 output polarity refer to CC1P description



- Bit 4 **CC2E**: Capture/Compare 2 output enable  
refer to CC1E description
- Bits 3:2 Reserved, always read as 0.
- Bit 1 **CC1P**: Capture/Compare 1 output polarity  
  - CC1 channel configured as output:**
  - 0: OC1 active high.
  - 1: OC1 active low.
  - CC1 channel configured as input:**
  - This bit selects whether IC1 or IC1 is used for trigger or capture operations.
  - 0: non-inverted: capture is done on a rising edge of IC1. When used as external trigger, IC1 is non-inverted.
  - 1: inverted: capture is done on a falling edge of IC1. When used as external trigger, IC1 is inverted.
- Bit 0 **CC1E**: Capture/Compare 1 output enable  
  - CC1 channel configured as output:**
  - 0: Off - OC1 is not active.
  - 1: On - OC1 signal is output on the corresponding output pin.
  - CC1 channel configured as input:**
  - This bit determines if a capture of the counter value can actually be done into the input capture/compare register 1 (TIMx\_CCR1) or not.
  - 0: Capture disabled.
  - 1: Capture enabled.

**Table 85. Output control bit for standard OCx channels**

CCxE bit	OCx output state
0	Output Disabled (OCx=0, OCx_EN=0)
1	OCx=OCxREF + Polarity, OCx_EN=1

*Note:* The state of the external IO pins connected to the standard OCx channels depends on the OCx channel state and the GPIO and AFIO registers.

### 14.4.10 TIMx counter (TIMx\_CNT)

Address offset: 0x24

Reset value: 0x0000

15	14	13	12	11	10	9	8	7	6	5	4	3	2	1	0
CNT[15:0]															
rw	rw	rw	rw	rw	rw	rw	rw	rw	rw	rw	rw	rw	rw	rw	rw

Bits 15:0 **CNT[15:0]**: Counter value

### 14.4.11 TIMx prescaler (TIMx\_PSC)

Address offset: 0x28

Reset value: 0x0000

15	14	13	12	11	10	9	8	7	6	5	4	3	2	1	0
PSC[15:0]															
rw	rw	rw	rw	rw	rw	rw	rw	rw	rw	rw	rw	rw	rw	rw	rw

Bits 15:0 **PSC[15:0]**: Prescaler value

The counter clock frequency CK\_CNT is equal to  $f_{CK\_PSC} / (PSC[15:0] + 1)$ .

PSC contains the value to be loaded in the active prescaler register at each update event.

### 14.4.12 TIMx auto-reload register (TIMx\_ARR)

Address offset: 0x2C

Reset value: 0x0000

15	14	13	12	11	10	9	8	7	6	5	4	3	2	1	0
ARR[15:0]															
rw	rw	rw	rw	rw	rw	rw	rw	rw	rw	rw	rw	rw	rw	rw	rw

Bits 15:0 **ARR[15:0]**: Prescaler value

ARR is the value to be loaded in the actual auto-reload register.

Refer to the [Section 14.3.1: Time-base unit on page 337](#) for more details about ARR update and behavior.

The counter is blocked while the auto-reload value is null.

### 14.4.13 TIMx capture/compare register 1 (TIMx\_CCR1)

Address offset: 0x34

Reset value: 0x0000

15	14	13	12	11	10	9	8	7	6	5	4	3	2	1	0
CCR1[15:0]															
rw	rw	rw	rw	rw	rw	rw	rw	rw	rw	rw	rw	rw	rw	rw	rw

Bits 15:0 **CCR1[15:0]**: Capture/Compare 1 value

**If channel CC1 is configured as output:**

CCR1 is the value to be loaded in the actual capture/compare 1 register (preload value).

It is loaded permanently if the preload feature is not selected in the TIMx\_CCMR1 register (bit OC1PE). Else the preload value is copied in the active capture/compare 1 register when an update event occurs.

The active capture/compare register contains the value to be compared to the counter TIMx\_CNT and signaled on OC1 output.

**If channel CC1 is configured as input:**

CCR1 is the counter value transferred by the last input capture 1 event (IC1).

### 14.4.14 TIMx capture/compare register 2 (TIMx\_CCR2)

Address offset: 0x38

Reset value: 0x0000

15	14	13	12	11	10	9	8	7	6	5	4	3	2	1	0
CCR2[15:0]															
rw	rw	rw	rw	rw	rw	rw	rw	rw	rw	rw	rw	rw	rw	rw	rw

Bits 15:0 **CCR2[15:0]**: Capture/Compare 2 value

**If channel CC2 is configured as output:**

CCR2 is the value to be loaded in the actual capture/compare 2 register (preload value). It is loaded permanently if the preload feature is not selected in the TIMx\_CCMR2 register (bit OC2PE). Else the preload value is copied in the active capture/compare 2 register when an update event occurs.

The active capture/compare register contains the value to be compared to the counter TIMx\_CNT and signalled on OC2 output.

**If channel CC2 is configured as input:**

CCR2 is the counter value transferred by the last input capture 2 event (IC2).

### 14.4.15 TIMx capture/compare register 3 (TIMx\_CCR3)

Address offset: 0x3C

Reset value: 0x0000

15	14	13	12	11	10	9	8	7	6	5	4	3	2	1	0
CCR3[15:0]															
rw	rw	rw	rw	rw	rw	rw	rw	rw	rw	rw	rw	rw	rw	rw	rw

Bits 15:0 **CCR3[15:0]**: Capture/Compare value

**If channel CC3 is configured as output:**

CCR3 is the value to be loaded in the actual capture/compare 3 register (preload value). It is loaded permanently if the preload feature is not selected in the TIMx\_CCMR3 register (bit OC3PE). Else the preload value is copied in the active capture/compare 3 register when an update event occurs.

The active capture/compare register contains the value to be compared to the counter TIMx\_CNT and signalled on OC3 output.

**If channel CC3 is configured as input:**

CCR3 is the counter value transferred by the last input capture 3 event (IC3).

### 14.4.16 TIMx capture/compare register 4 (TIMx\_CCR4)

Address offset: 0x40

Reset value: 0x0000

15	14	13	12	11	10	9	8	7	6	5	4	3	2	1	0
CCR4[15:0]															
rw	rw	rw	rw	rw	rw	rw	rw	rw	rw	rw	rw	rw	rw	rw	rw

Bits 15:0 **CCR4[15:0]**: Capture/Compare value

1/ if CC4 channel is configured as output (CC4S bits):

CCR4 is the value to be loaded in the actual capture/compare 4 register (preload value).

It is loaded permanently if the preload feature is not selected in the TIMx\_CCMR4 register (bit OC4PE). Else the preload value is copied in the active capture/compare 4 register when an update event occurs.

The active capture/compare register contains the value to be compared to the counter TIMx\_CNT and signalled on OC4 output.

2/ if CC4 channel is configured as input (CC4S bits in TIMx\_CCMR4 register):

CCR4 is the counter value transferred by the last input capture 4 event (IC4).

### 14.4.17 TIMx DMA control register (TIMx\_DCR)

Address offset: 0x48

Reset value: 0x0000

15	14	13	12	11	10	9	8	7	6	5	4	3	2	1	0				
Reserved					DBL[4:0]					Reserved					DBA[4:0]				
					rw	rw	rw	rw	rw						rw	rw	rw	rw	rw

Bits 15:13 Reserved, always read as 0

Bits 12:8 **DBL[4:0]**: DMA burst length

This 5-bits vector defines the length of DMA transfers (the timer recognizes a burst transfer when a read or a write access is done to the TIMx\_DMAR address), i.e. the number of bytes to be transferred.

00000: 1 byte,

00001: 2 bytes,

00010: 3 bytes,

...

10001: 18 bytes.

Bits 7:5 Reserved, always read as 0

Bits 4:0 **DBA[4:0]**: DMA base address

This 5-bit vector defines the base-address for DMA transfers (when read/write access are done through the TIMx\_DMAR address). DBA is defined as an offset starting from the address of the TIMx\_CR1 register.

Example:

00000: TIMx\_CR1,

00001: TIMx\_CR2,

00010: TIMx\_SMCR,

...

### 14.4.18 TIMx DMA address for full transfer (TIMx\_DMAR)

Address offset: 0x4C

Reset value: 0x0000

	15	14	13	12	11	10	9	8	7	6	5	4	3	2	1	0
	DMAB[15:0]															
	rw	rw	rw	rw	rw	rw	rw	rw	rw	rw	rw	rw	rw	rw	rw	rw

Bits 15:0 **DMAB[15:0]**: DMA register for burst accesses

A read or write access to the DMAR register accesses the register located at the address:

“(TIMx\_CR1 address) + DBA + (DMA index)” in which:

TIMx\_CR1 address is the address of the control register 1,

DBA is the DMA base address configured in the TIMx\_DCR register,

DMA index is the offset automatically controlled by the DMA transfer, depending on the length of the transfer DBL in the TIMx\_DCR register.

### 14.4.19 TIMx register map

TIMx registers are mapped as 16-bit addressable registers as described in the table below:

**Table 86. TIMx register map and reset values**

Offset	Register	31	30	29	28	27	26	25	24	23	22	21	20	19	18	17	16	15	14	13	12	11	10	9	8	7	6	5	4	3	2	1	0													
0x00	<b>TIMx_CR1</b> Reset value	Reserved																							CKD [1:0]	ARPE	CMS [1:0]	DIR	OPM	URS	UDIS	CEN														
0x04	<b>TIMx_CR2</b> Reset value	Reserved																							T1S	MMS[2:0]	CCDS	Reserved																		
0x08	<b>TIMx_SMCR</b> Reset value	Reserved													ETP	ECE	ETPS [1:0]	ETF[3:0]	MSM	TS[2:0]	Reserved		SMS[2:0]																							
0x0C	<b>TIMx_DIER</b> Reset value	Reserved													TDE	COMDE	CC4DE	CC3DE	CC2DE	CC1DE	UDE	Reserved	TIE	Reserved	CC4IE	CC3IE	CC2IE	CC1IE	UIE																	
0x10	<b>TIMx_SR</b> Reset value	Reserved													CC4OF	CC3OF	CC2OF	CC1OF	Reserved	TIF	Reserved	CC4IF	CC3IF	CC2IF	CC1IF	UIF																				
0x14	<b>TIMx_EGR</b> Reset value	Reserved																							TG	Reserved	CC4G	CC3G	CC2G	CC1G	UG															
0x18	<b>TIMx_CCMR1</b> <i>Output Compare mode</i> Reset value	Reserved													OC2OE	OC2M [2:0]	OC2PE	OC2FE	CC2S [1:0]	OC1CE	OC1M [2:0]	OC1PE	OC1FE	CC1S [1:0]																						
	<b>TIMx_CCMR1</b> <i>Input Capture mode</i> Reset value	Reserved													IC2F[3:0]	IC2PSC [1:0]	CC2S [1:0]	IC1F[3:0]	IC1PSC [1:0]	CC1S [1:0]																										

Table 86. TIMx register map and reset values (continued)

Offset	Register	31	30	29	28	27	26	25	24	23	22	21	20	19	18	17	16	15	14	13	12	11	10	9	8	7	6	5	4	3	2	1	0		
0x1C	TIMx_CCMR2 Output Compare mode Reset value	Reserved																O24CE	OC4M [2:0]		OC4PE	OC4FE	CC4S [1:0]	OC3CE	OC3M [2:0]		OC3PE	OC3FE	CC3S [1:0]						
	TIMx_CCMR2 Input Capture mode Reset value	Reserved																IC4F[3:0]			IC4PSC [1:0]	CC4S [1:0]	IC3F[3:0]			IC3PSC [1:0]	CC3S [1:0]								
0x20	TIMx_CCER Reset value	Reserved																CC4P	CC4E	Reserved	CC3P	CC3E	Reserved	CC2P	CC2E	Reserved	CC1P	CC1E							
0x24	TIMx_CNT Reset value	Reserved																CNT[15:0]																	
0x28	TIMx_PSC Reset value	Reserved																PSC[15:0]																	
0x2C	TIMx_ARR Reset value	Reserved																ARR[15:0]																	
0x30	Reserved																																		
0x34	TIMx_CCR1 Reset value	Reserved																CCR1[15:0]																	
0x38	TIMx_CCR2 Reset value	Reserved																CCR2[15:0]																	
0x3C	TIMx_CCR3 Reset value	Reserved																CCR3[15:0]																	
0x40	TIMx_CCR4 Reset value	Reserved																CCR4[15:0]																	
0x44	Reserved																																		
0x48	TIMx_DCR Reset value	Reserved																DBL[4:0]				Reserved	DBA[4:0]												
0x4C	TIMx_DMAR Reset value	Reserved																DMAB[15:0]																	

Refer to [Table 1 on page 44](#) for the register boundary addresses.

## 15 General-purpose timers (TIM9 to TIM14)

**Low-density devices** are STM32F101xx, STM32F102xx and STM32F103xx microcontrollers where the Flash memory density ranges between 16 and 32 Kbytes.

**Medium-density devices** are STM32F101xx, STM32F102xx and STM32F103xx microcontrollers where the Flash memory density ranges between 64 and 128 Kbytes.

**High-density devices** are STM32F101xx and STM32F103xx microcontrollers where the Flash memory density ranges between 256 and 512 Kbytes.

**XL-density devices** are STM32F101xx and STM32F103xx microcontrollers where the Flash memory density ranges between 768 Kbytes and 1 Mbyte.

**Connectivity line devices** are STM32F105xx and STM32F107xx microcontrollers.

This section applies to XL-density devices only.

### 15.1 TIMx introduction

The general-purpose timers consist of a 16-bit auto-reload counter driven by a programmable prescaler.

TIM9 to TIM14 may be used for a variety of purposes, including measuring the pulse lengths of input signals (input capture) or generating output waveforms (output compare, PWM).

Pulse lengths and waveform periods can be modulated from a few microseconds to several milliseconds using the timer prescaler and the RCC clock controller prescalers.

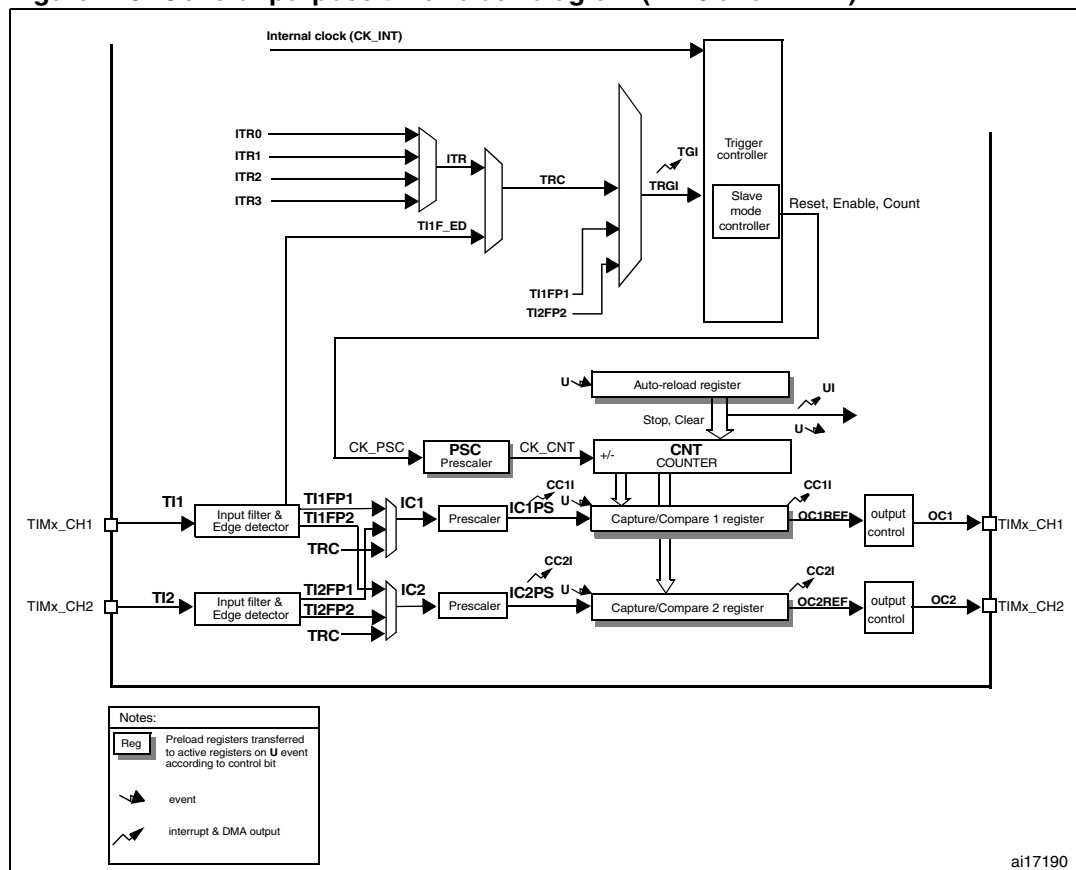
General-purpose TIM9 to TIM14 timers on the one hand and general-purpose TIM2, TIM3, TIM4 and TIM5 timers on the second hand are completely independent, and do not share any resources. They can be synchronized together as described in [Section 15.4.12](#).

## 15.2 General-purpose timers TIM9 and TIM12

The features of general-purpose timers TIM9/TIM12 include:

- 16-bit auto-reload upcounter
- 16-bit programmable prescaler used to divide (also “on the fly”) the counter clock frequency by any factor between 1 and 65535
- Up to 2 independent channels for:
  - Input capture
  - Output compare
  - PWM generation (edge-aligned mode)
  - One-pulse mode output
- Synchronization circuit to control the timer with external signals and to interconnect several timers together
- Interrupt generation on the following events:
  - Update: counter overflow, counter initialization (by software or internal trigger)
  - Trigger event (counter start, stop, initialization or count by internal trigger)
  - Input capture
  - Output compare

Figure 146. General-purpose timer block diagram (TIM9 and TIM12)



ai17190

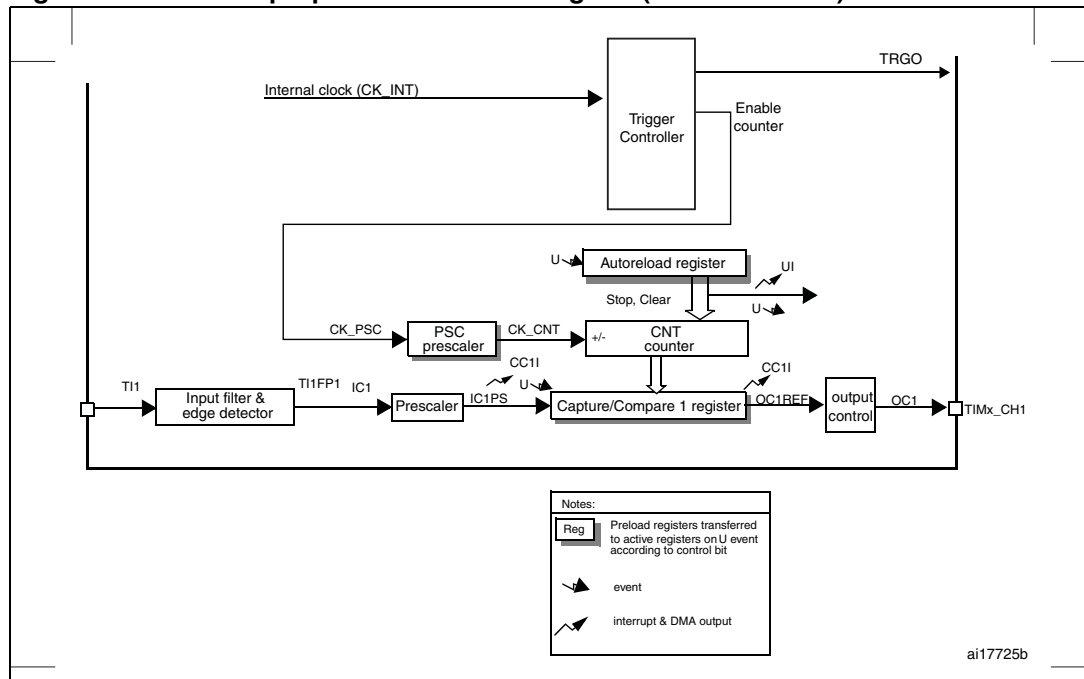


### 15.3 General-purpose timers TIM10/TIM11 and TIM13/TIM14

The features of general-purpose timers TIM10/TIM11 and TIM13/TIM14 include:

- 16-bit auto-reload upcounter
- 16-bit programmable prescaler used to divid (also “on the fly”) the counter clock frequency by any factor between 1 and 65535
- independent channel for:
  - Input capture
  - Output compare
  - PWM generation (edge-aligned mode)
- Interrupt generation on the following events:
  - Update: counter overflow, counter initialization (by software or internal trigger)
  - Input capture
  - Output compare

**Figure 147. General-purpose timer block diagram (TIM10/11/13/14)**



## 15.4 TIMx functional description

### 15.4.1 Time-base unit

The main block of the programmable advanced-control timer is a 16-bit counter with its related auto-reload register. The counter can count up. The counter clock can be divided by a prescaler.

The counter, the auto-reload register and the prescaler register can be written or read by software. This is true even when the counter is running.

The time-base unit includes:

- Counter register (TIMx\_CNT)
- Prescaler register (TIMx\_PSC)
- Auto-reload register (TIMx\_ARR)

The auto-reload register is preloaded. Writing to or reading from the auto-reload register accesses the preload register. The content of the preload register are transferred into the shadow register permanently or at each update event (UEV), depending on the auto-reload preload enable bit (ARPE) in TIMx\_CR1 register. The update event is sent when the counter reaches the overflow and if the UDIS bit equals 0 in the TIMx\_CR1 register. It can also be generated by software. The generation of the update event is described in detailed for each configuration.

The counter is clocked by the prescaler output CK\_CNT, which is enabled only when the counter enable bit (CEN) in TIMx\_CR1 register is set (refer also to the slave mode controller description to get more details on counter enabling).

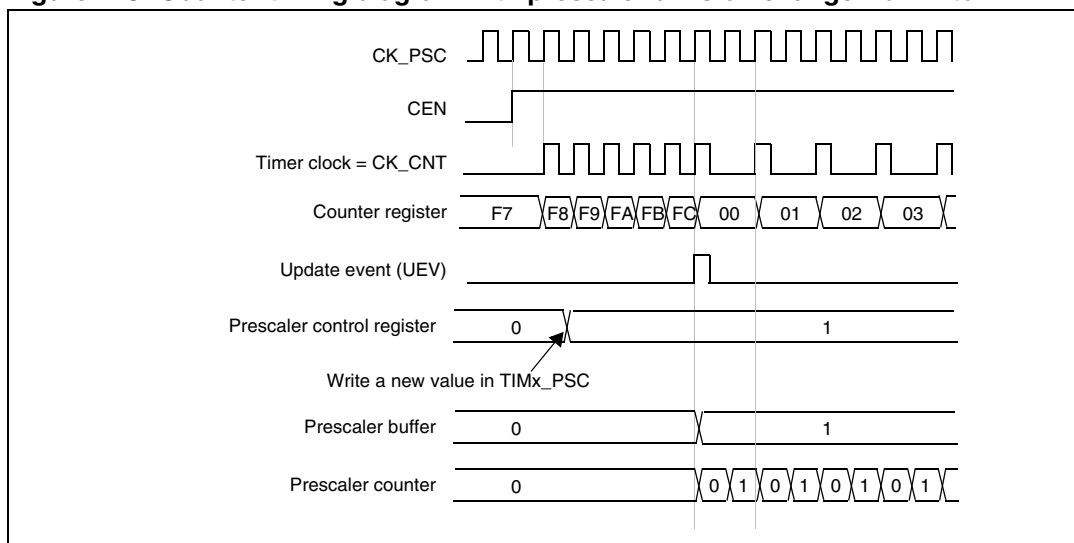
Note that the counter starts counting 1 clock cycle after setting the CEN bit in the TIMx\_CR1 register.

#### Prescaler description

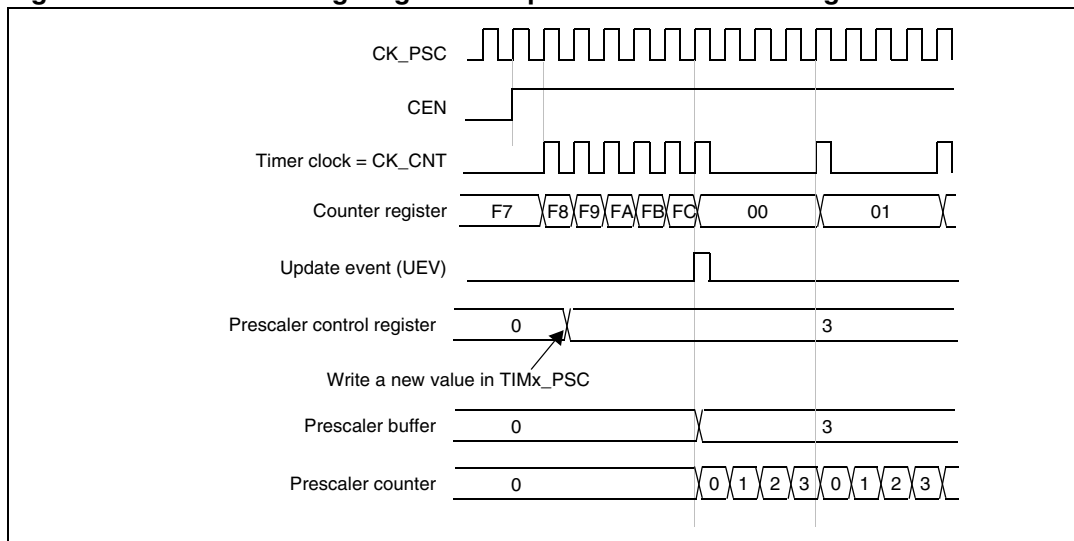
The prescaler can divide the counter clock frequency by any factor between 1 and 65536. It is based on a 16-bit counter controlled through a 16-bit register (in the TIMx\_PSC register). It can be changed on the fly as this control register is buffered. The new prescaler ratio is taken into account at the next update event.

*Figure 149* and *Figure 150* give some examples of the counter behavior when the prescaler ratio is changed on the fly:

**Figure 148. Counter timing diagram with prescaler division change from 1 to 2**



**Figure 149. Counter timing diagram with prescaler division change from 1 to 4**



## 15.4.2 Counter modes

### Upcounting mode

In upcounting mode, the counter counts from 0 to the auto-reload value (content of the TIMx\_ARR register), then restarts from 0 and generates a counter overflow event.

Setting the UG bit in the TIMx\_EGR register (by software or by using the slave mode controller) also generates an update event.

The UEV event can be disabled by software by setting the UDIS bit in the TIMx\_CR1 register. This is to avoid updating the shadow registers while writing new values in the preload registers. Then no update event occurs until the UDIS bit has been written to 0. However, the counter restarts from 0, as well as the counter of the prescaler (but the prescale rate does not change). In addition, if the URS bit (update request selection) in TIMx\_CR1 register is set, setting the UG bit generates an update event UEV but without

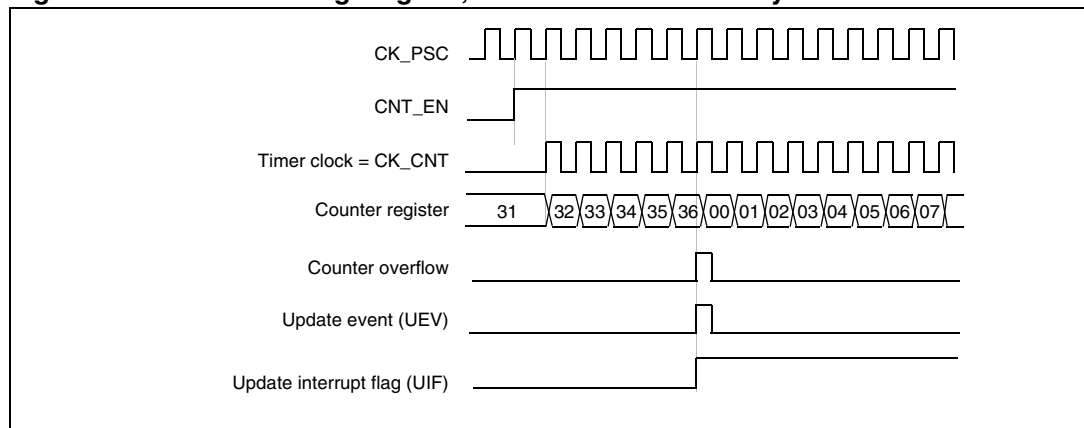
setting the UIF flag (thus no interrupt is sent). This is to avoid generating both update and capture interrupts when clearing the counter on the capture event.

When an update event occurs, all the registers are updated and the update flag (UIF bit in TIMx\_SR register) is set (depending on the URS bit):

- The auto-reload shadow register is updated with the preload value (TIMx\_ARR),
- The buffer of the prescaler is reloaded with the preload value (content of the TIMx\_PSC register).

The following figures show some examples of the counter behavior for different clock frequencies when TIMx\_ARR=0x36.

**Figure 150. Counter timing diagram, internal clock divided by 1**



**Figure 151. Counter timing diagram, internal clock divided by 2**

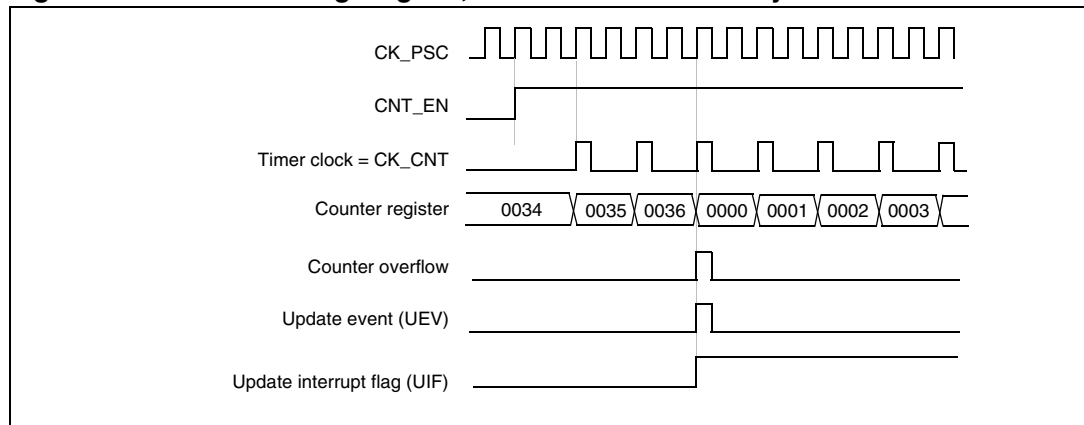


Figure 152. Counter timing diagram, internal clock divided by 4

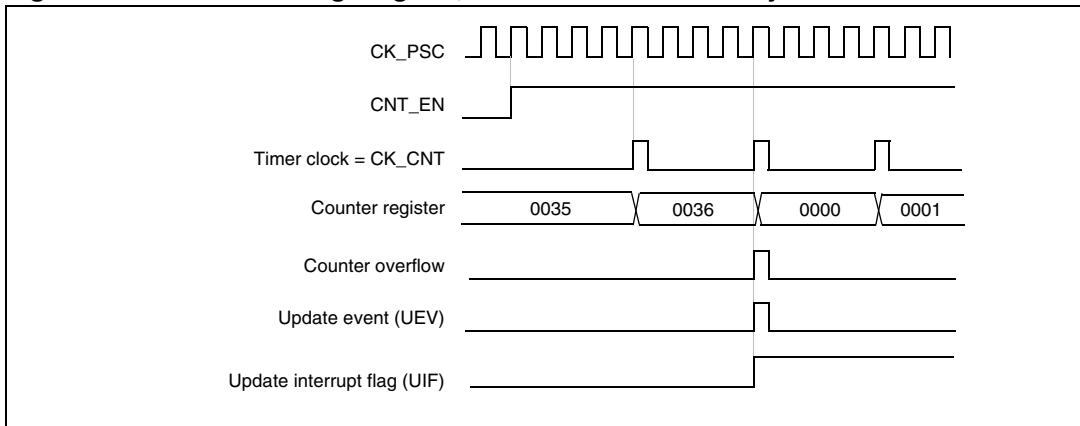


Figure 153. Counter timing diagram, internal clock divided by N

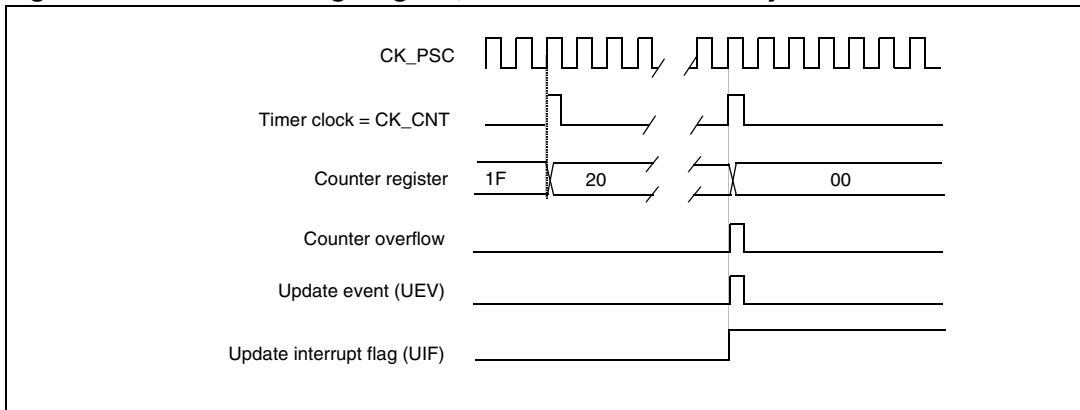
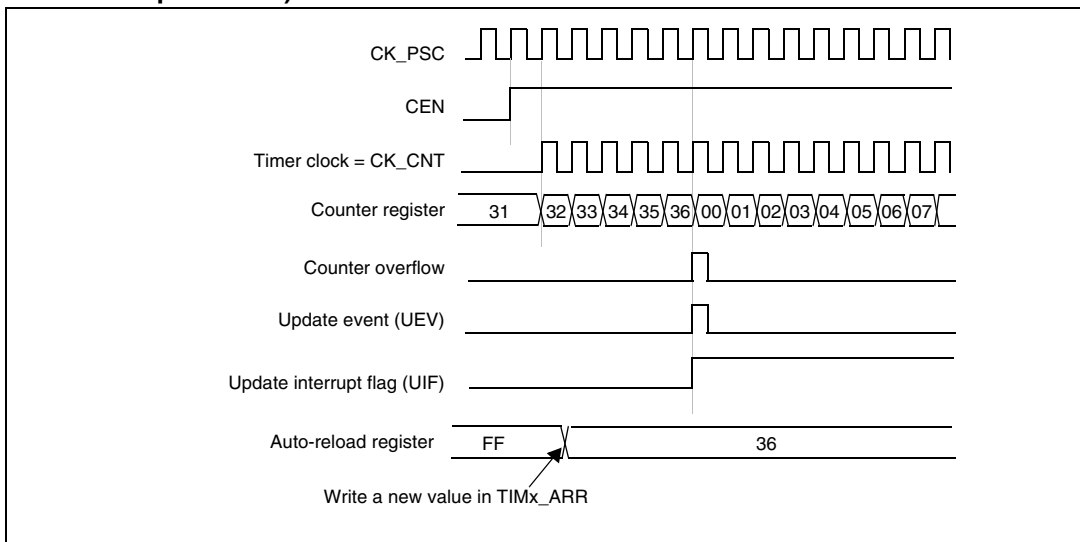
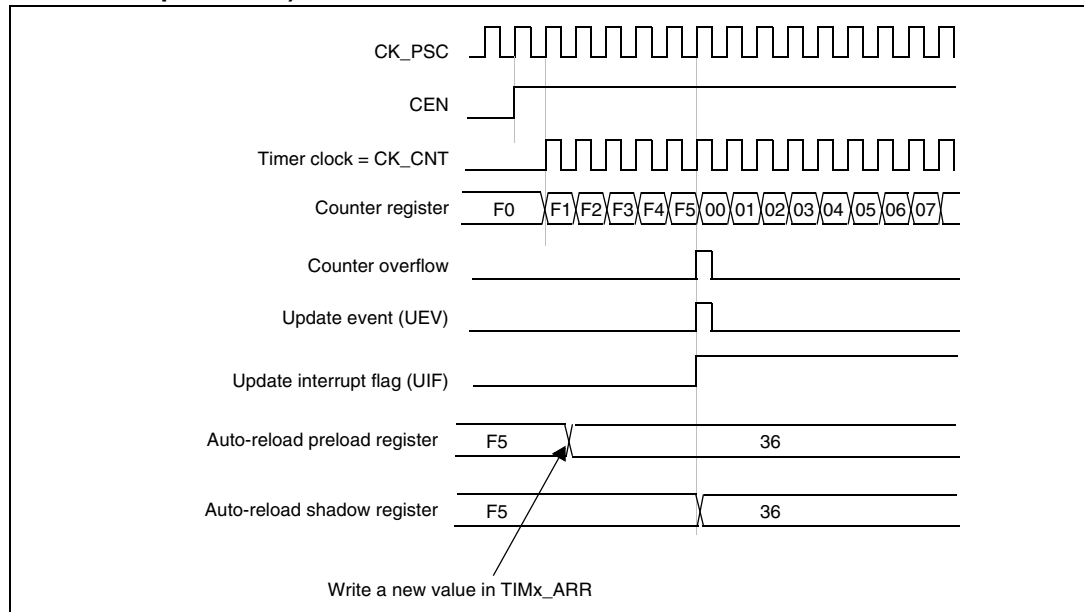


Figure 154. Counter timing diagram, update event when ARPE=0 (TIMx\_ARR not preloaded)



**Figure 155. Counter timing diagram, update event when ARPE=1 (TIMx\_ARR preloaded)**



### 15.4.3 Clock selection

The counter clock can be provided by the following clock sources:

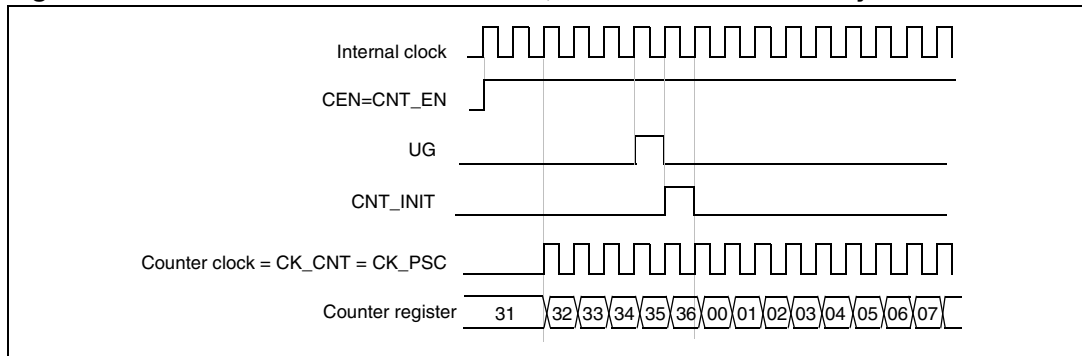
- Internal clock (CK\_INT)
- External clock mode1: external input pin (TIx)
- Internal trigger inputs (ITRx) (for TIM9 and TIM12): using one timer as the prescaler for another timer, for example, you can configure TIM2 to act as a prescaler for TIM9. Refer to [Using one timer as prescaler for another](#) for more details.

#### Internal clock source (CK\_INT)

If the slave mode controller is disabled (SMS=000), then the CEN, DIR (in the TIMx\_CR1 register) and UG bits (in the TIMx\_EGR register) are actual control bits and can be changed only by software (except UG which remains cleared automatically). As soon as the CEN bit is written to 1, the prescaler is clocked by the internal clock CK\_INT.

[Figure 156](#) shows the behavior of the control circuit and the upcounter in normal mode, without prescaler.

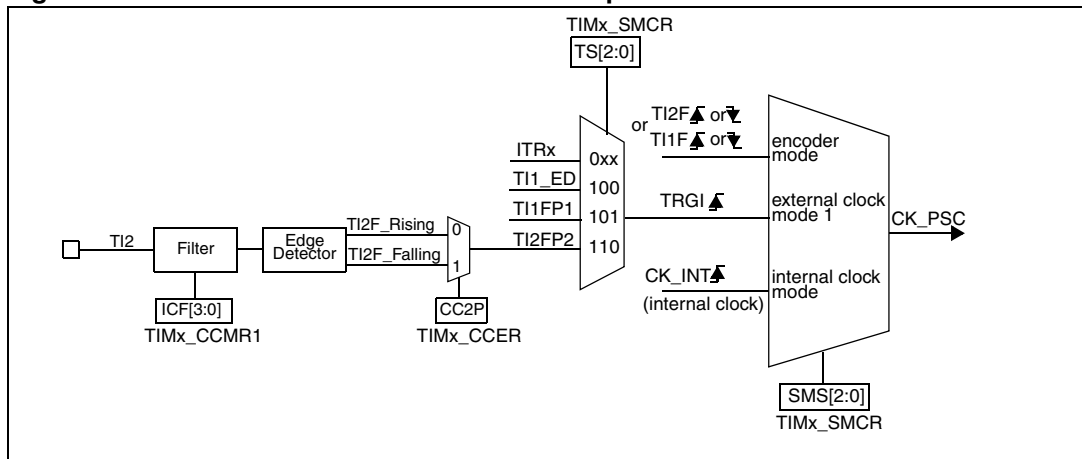
**Figure 156. Control circuit in normal mode, internal clock divided by 1**



**External clock source mode 1**

This mode is selected when SMS=111 in the TIMx\_SMCR register. The counter can count at each rising or falling edge on a selected input.

**Figure 157. TI2 external clock connection example**



For example, to configure the upcounter to count in response to a rising edge on the TI2 input, use the following procedure:

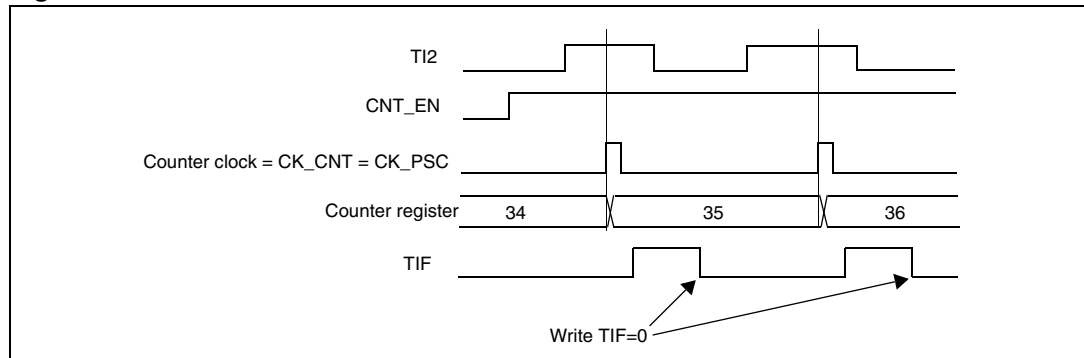
1. Configure channel 2 to detect rising edges on the TI2 input by writing CC2S = '01' in the TIMx\_CCMR1 register.
2. Configure the input filter duration by writing the IC2F[3:0] bits in the TIMx\_CCMR1 register (if no filter is needed, keep IC2F=0000).
3. Select rising edge polarity by writing CC2P=0 in the TIMx\_CCER register.
4. Configure the timer in external clock mode 1 by writing SMS=111 in the TIMx\_SMCR register.
5. Select TI2 as the trigger input source by writing TS=110 in the TIMx\_SMCR register.
6. Enable the counter by writing CEN=1 in the TIMx\_CR1 register.

*Note:* The capture prescaler is not used for triggering, so you don't need to configure it.

When a rising edge occurs on TI2, the counter counts once and the TIF flag is set.

The delay between the rising edge on TI2 and the actual clock of the counter is due to the resynchronization circuit on TI2 input.

Figure 158. Control circuit in external clock mode 1



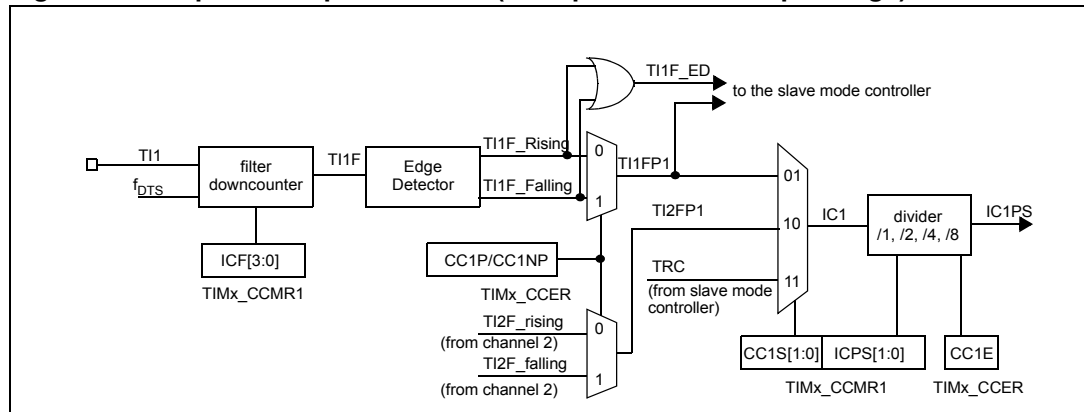
### 15.4.4 Capture/compare channels

Each Capture/Compare channel is built around a capture/compare register (including a shadow register), a input stage for capture (with digital filter, multiplexing and prescaler) and an output stage (with comparator and output control).

Figure 159 to Figure 161 give an overview of one Capture/Compare channel.

The input stage samples the corresponding TIx input to generate a filtered signal TIxF. Then, an edge detector with polarity selection generates a signal (TIxFPx) which can be used as trigger input by the slave mode controller or as the capture command. It is prescaled before the capture register (ICxPS).

Figure 159. Capture/compare channel (example: channel 1 input stage)



The output stage generates an intermediate waveform which is then used for reference: OCxRef (active high). The polarity acts at the end of the chain.



Figure 160. Capture/compare channel 1 main circuit

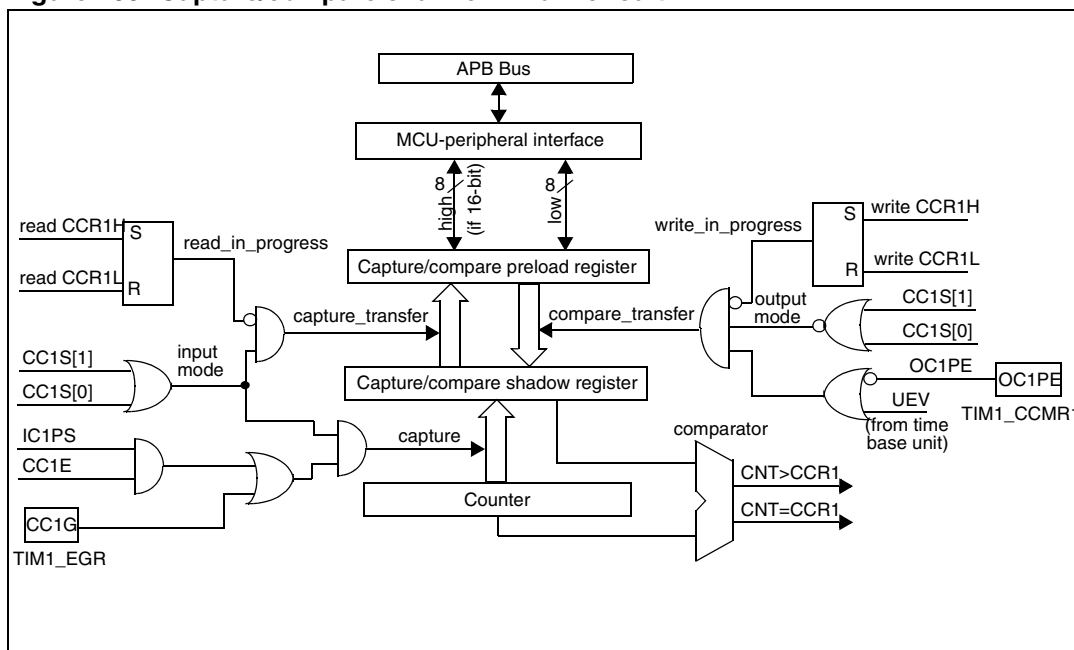
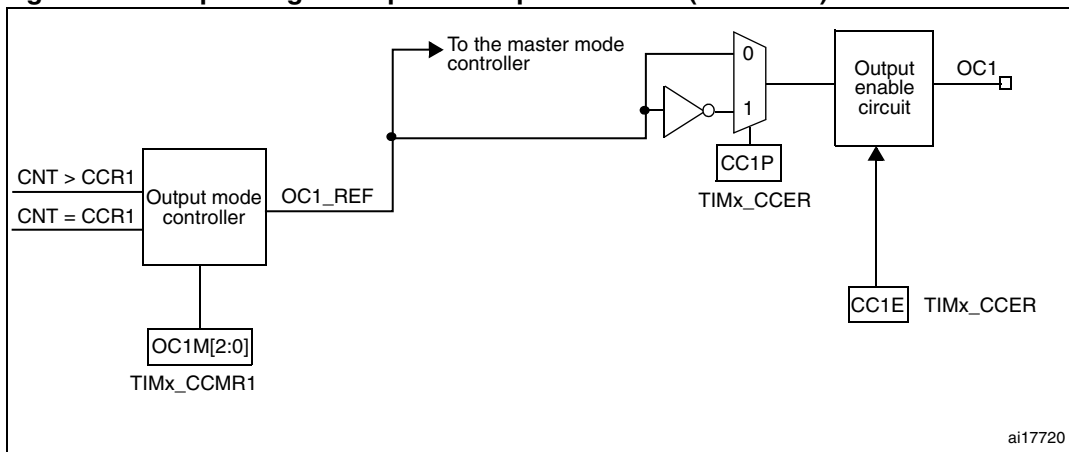


Figure 161. Output stage of capture/compare channel (channel 1)



The capture/compare block is made of one preload register and one shadow register. Write and read always access the preload register.

In capture mode, captures are actually done in the shadow register, which is copied into the preload register.

In compare mode, the content of the preload register is copied into the shadow register which is compared to the counter.

### 15.4.5 Input capture mode

In Input capture mode, the Capture/Compare Registers (TIMx\_CCRx) are used to latch the value of the counter after a transition detected by the corresponding ICx signal. When a capture occurs, the corresponding CCxIF flag (TIMx\_SR register) is set and an interrupt or a DMA request can be sent if they are enabled. If a capture occurs while the CCxIF flag was already high, then the over-capture flag CCxOF (TIMx\_SR register) is set. CCxIF can be

cleared by software by writing it to '0' or by reading the captured data stored in the TIMx\_CCRx register. CCxOF is cleared when you write it to '0'.

The following example shows how to capture the counter value in TIMx\_CCR1 when TI1 input rises. To do this, use the following procedure:

- Select the active input: TIMx\_CCR1 must be linked to the TI1 input, so write the CC1S bits to 01 in the TIMx\_CCMR1 register. As soon as CC1S becomes different from 00, the channel is configured in input and the TIMx\_CCR1 register becomes read-only.
- Program the input filter duration you need with respect to the signal you connect to the timer (when the input is one of the TIx (ICxF bits in the TIMx\_CCMRx register). Let's imagine that, when toggling, the input signal is not stable during at most 5 internal clock cycles. We must program a filter duration longer than these 5 clock cycles. We can validate a transition on TI1 when 8 consecutive samples with the new level have been detected (sampled at  $f_{DTS}$  frequency). Then write IC1F bits to 0011 in the TIMx\_CCMR1 register.
- Select the edge of the active transition on the TI1 channel by writing CC1P bit to 0 in the TIMx\_CCER register (rising edge in this case).
- Program the input prescaler. In our example, we wish the capture to be performed at each valid transition, so the prescaler is disabled (write IC1PS bits to '00' in the TIMx\_CCMR1 register).
- Enable capture from the counter into the capture register by setting the CC1E bit in the TIMx\_CCER register.
- If needed, enable the related interrupt request by setting the CC1IE bit in the TIMx\_DIER register.

When an input capture occurs:

- The TIMx\_CCR1 register gets the value of the counter on the active transition.
- CC1IF flag is set (interrupt flag). CC1OF is also set if at least two consecutive captures occurred whereas the flag was not cleared.
- An interrupt is generated depending on the CC1IE bit.

In order to handle the overcapture, it is recommended to read the data before the overcapture flag. This is to avoid missing an overcapture which could happen after reading the flag and before reading the data.

*Note:* IC interrupt requests can be generated by software by setting the corresponding CCxG bit in the TIMx\_EGR register.

#### 15.4.6 PWM input mode (only for TIM9/12)

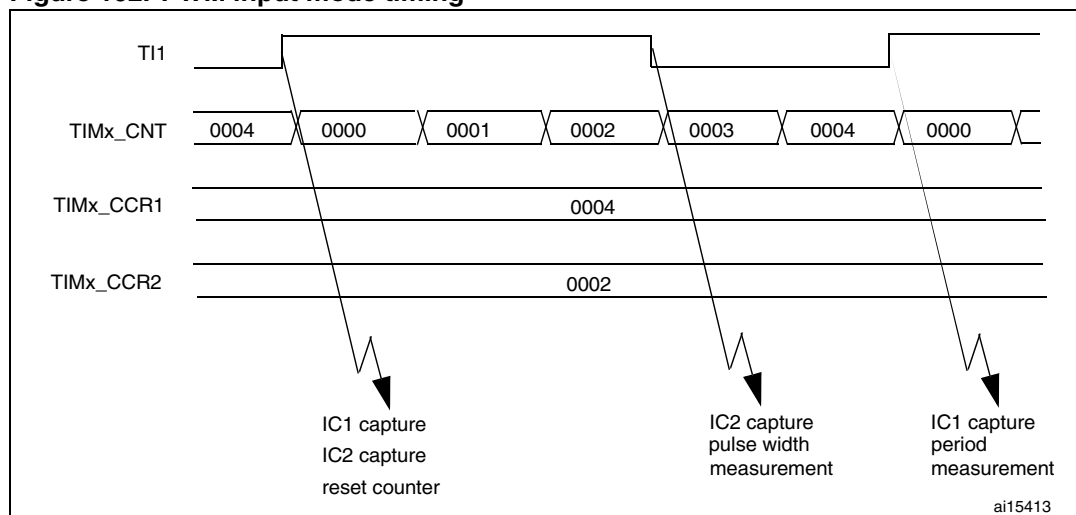
This mode is a particular case of input capture mode. The procedure is the same except:

- Two ICx signals are mapped on the same TIx input.
- These 2 ICx signals are active on edges with opposite polarity.
- One of the two TIxFP signals is selected as trigger input and the slave mode controller is configured in reset mode.

For example, you can measure the period (in TIMx\_CCR1 register) and the duty cycle (in TIMx\_CCR2 register) of the PWM applied on TI1 using the following procedure (depending on CK\_INT frequency and prescaler value):

- Select the active input for TIMx\_CCR1: write the CC1S bits to 01 in the TIMx\_CCMR1 register (TI1 selected).
- Select the active polarity for TI1FP1 (used both for capture in TIMx\_CCR1 and counter clear): write the CC1P bit to '0' (active on rising edge).
- Select the active input for TIMx\_CCR2: write the CC2S bits to 10 in the TIMx\_CCMR1 register (TI1 selected).
- Select the active polarity for TI1FP2 (used for capture in TIMx\_CCR2): write the CC2P bit to '1' (active on falling edge).
- Select the valid trigger input: write the TS bits to 101 in the TIMx\_SMCR register (TI1FP1 selected).
- Configure the slave mode controller in reset mode: write the SMS bits to 100 in the TIMx\_SMCR register.
- Enable the captures: write the CC1E and CC2E bits to '1' in the TIMx\_CCER register.

**Figure 162. PWM input mode timing**



1. The PWM input mode can be used only with the TIMx\_CH1/TIMx\_CH2 signals due to the fact that only TI1FP1 and TI2FP2 are connected to the slave mode controller.

### 15.4.7 Forced output mode

In output mode (CCxS bits = 00 in the TIMx\_CCMRx register), each output compare signal (OCxREF and then OCx/OCxN) can be forced to active or inactive level directly by software, independently of any comparison between the output compare register and the counter.

To force an output compare signal (OCxREF/OCx) to its active level, you just need to write 101 in the OCxM bits in the corresponding TIMx\_CCMRx register. Thus OCxREF is forced high (OCxREF is always active high) and OCx get opposite value to CCxP polarity bit.

For example: CCxP=0 (OCx active high) => OCx is forced to high level.

The OCxREF signal can be forced low by writing the OCxM bits to 100 in the TIMx\_CCMRx register.

Anyway, the comparison between the TIMx\_CCRx shadow register and the counter is still performed and allows the flag to be set. Interrupt requests can be sent accordingly. This is described in the output compare mode section below.

### 15.4.8 Output compare mode

This function is used to control an output waveform or indicating when a period of time has elapsed.

When a match is found between the capture/compare register and the counter, the output compare function:

- Assigns the corresponding output pin to a programmable value defined by the output compare mode (OCxM bits in the TIMx\_CCMRx register) and the output polarity (CCxP bit in the TIMx\_CCER register). The output pin can keep its level (OCxM=000), be set active (OCxM=001), be set inactive (OCxM=010) or can toggle (OCxM=011) on match.
- Sets a flag in the interrupt status register (CCxIF bit in the TIMx\_SR register).
- Generates an interrupt if the corresponding interrupt mask is set (CCXIE bit in the TIMx\_DIER register).

The TIMx\_CCRx registers can be programmed with or without preload registers using the OCxPE bit in the TIMx\_CCMRx register.

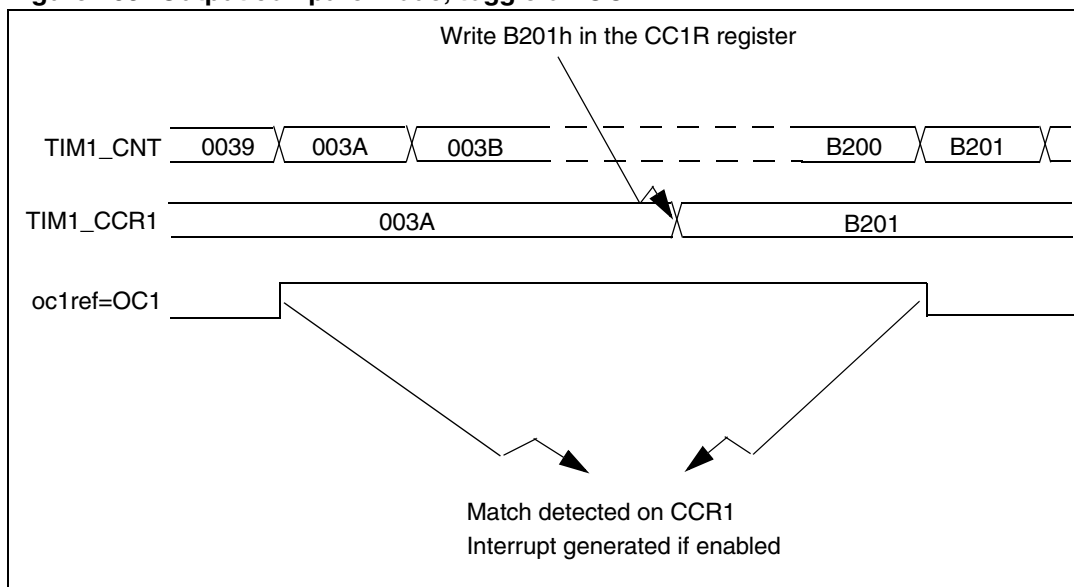
In output compare mode, the update event UEV has no effect on OCxREF and OCx output. The timing resolution is one count of the counter. Output compare mode can also be used to output a single pulse (in One-pulse mode).

Procedure:

1. Select the counter clock (internal, external, prescaler).
2. Write the desired data in the TIMx\_ARR and TIMx\_CCRx registers.
3. Set the CCXIE bit if an interrupt request is to be generated.
4. Select the output mode. For example:
  - Write OCxM = 011 to toggle OCx output pin when CNT matches CCRx
  - Write OCxPE = 0 to disable preload register
  - Write CCxP = 0 to select active high polarity
  - Write CCxE = 1 to enable the output
5. Enable the counter by setting the CEN bit in the TIMx\_CR1 register.

The TIMx\_CCRx register can be updated at any time by software to control the output waveform, provided that the preload register is not enabled (OCxPE='0', else TIMx\_CCRx shadow register is updated only at the next update event UEV). An example is given in [Figure 163](#).

**Figure 163. Output compare mode, toggle on OC1.**



### 15.4.9 PWM mode

Pulse Width Modulation mode allows you to generate a signal with a frequency determined by the value of the TIMx\_ARR register and a duty cycle determined by the value of the TIMx\_CCRx register.

The PWM mode can be selected independently on each channel (one PWM per OCx output) by writing '110' (PWM mode 1) or '111' (PWM mode 2) in the OCxM bits in the TIMx\_CCMRx register. You must enable the corresponding preload register by setting the OCxPE bit in the TIMx\_CCMRx register, and eventually the auto-reload preload register (in upcounting or center-aligned modes) by setting the ARPE bit in the TIMx\_CR1 register.

As the preload registers are transferred to the shadow registers only when an update event occurs, before starting the counter, you have to initialize all the registers by setting the UG bit in the TIMx\_EGR register.

The OCx polarity is software programmable using the CCxP bit in the TIMx\_CCER register. It can be programmed as active high or active low. The OCx output is enabled by the CCxE bit in the TIMx\_CCER register. Refer to the TIMx\_CCERx register description for more details.

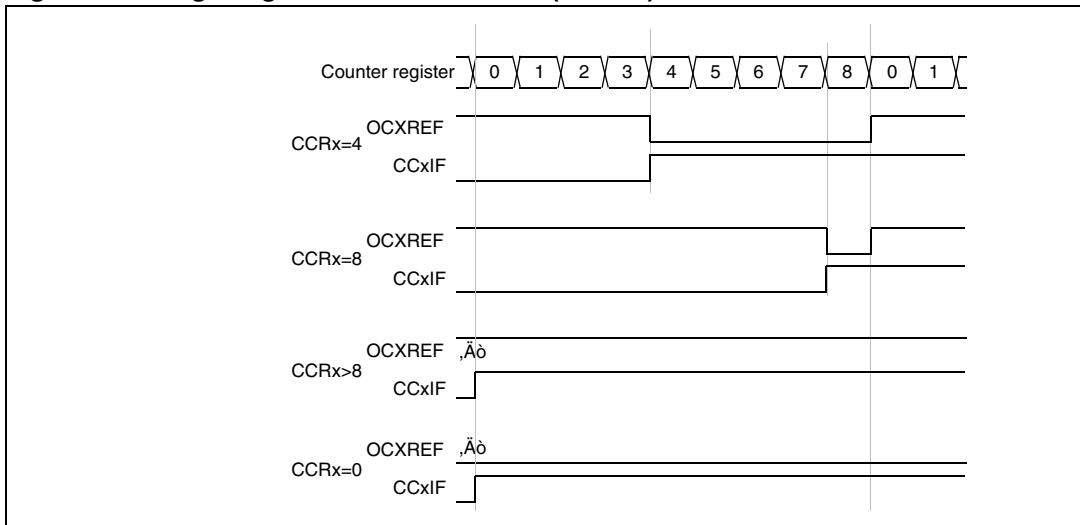
In PWM mode (1 or 2), TIMx\_CNT and TIMx\_CCRx are always compared to determine whether  $TIMx\_CNT \leq TIMx\_CCRx$ .

The timer is able to generate PWM in edge-aligned mode only since the counter is upcounting.

#### PWM edge-aligned mode

In the following example, we consider PWM mode 1. The reference PWM signal OCxREF is high as long as  $TIMx\_CNT < TIMx\_CCRx$  else it becomes low. If the compare value in TIMx\_CCRx is greater than the auto-reload value (in TIMx\_ARR) then OCxREF is held at '1'. If the compare value is 0 then OCxRef is held at '0'. [Figure 164](#) shows some edge-aligned PWM waveforms in an example where  $TIMx\_ARR=8$ .

Figure 164. Edge-aligned PWM waveforms (ARR=8)



### 15.4.10 One-pulse mode (only for TIM9/12)

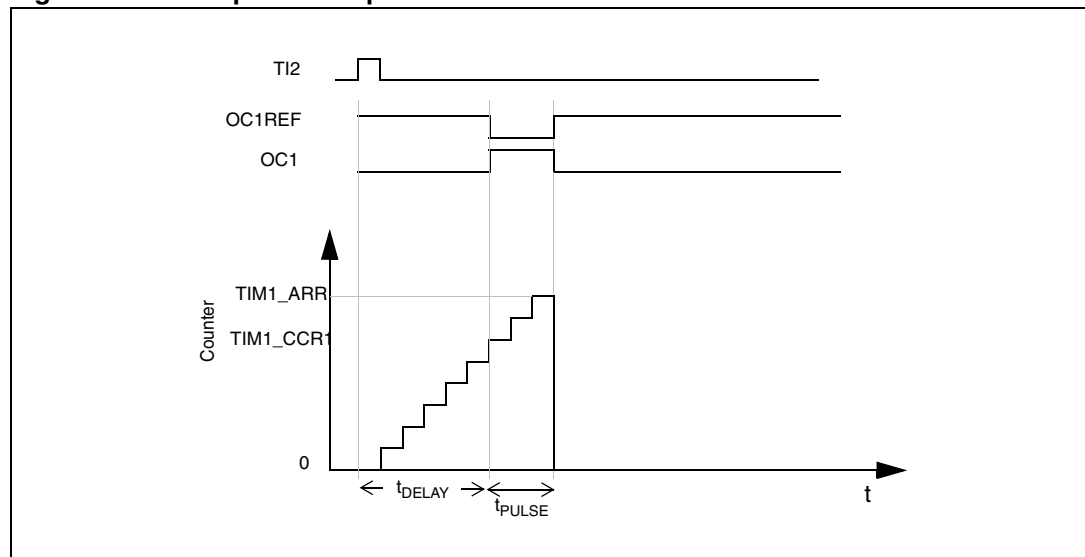
One-pulse mode (OPM) is a particular case of the previous modes. It allows the counter to be started in response to a stimulus and to generate a pulse with a programmable length after a programmable delay.

Starting the counter can be controlled through the slave mode controller. Generating the waveform can be done in output compare mode or PWM mode. You select One-pulse mode by setting the OPM bit in the TIMx\_CR1 register. This makes the counter stop automatically at the next update event UEV.

A pulse can be correctly generated only if the compare value is different from the counter initial value. Before starting (when the timer is waiting for the trigger), the configuration must be:

- In upcounting:  $CNT < CCRx \leq ARR$  (in particular,  $0 < CCRx$ )
- In downcounting:  $CNT > CCRx$

**Figure 165. Example of one pulse mode.**



For example you may want to generate a positive pulse on OC1 with a length of  $t_{PULSE}$  and after a delay of  $t_{DELAY}$  as soon as a positive edge is detected on the TI2 input pin.

Let's use TI2FP2 as trigger 1:

- Map TI2FP2 to TI2 by writing  $CC2S='01'$  in the TIMx\_CCMR1 register.
- TI2FP2 must detect a rising edge, write  $CC2P='0'$  in the TIMx\_CCER register.
- Configure TI2FP2 as trigger for the slave mode controller (TRGI) by writing  $TS='110'$  in the TIMx\_SMCR register.
- TI2FP2 is used to start the counter by writing SMS to '110' in the TIMx\_SMCR register (trigger mode).

The OPM waveform is defined by writing the compare registers (taking into account the clock frequency and the counter prescaler).

- The  $t_{\text{DELAY}}$  is defined by the value written in the TIMx\_CCR1 register.
- The  $t_{\text{PULSE}}$  is defined by the difference between the auto-reload value and the compare value (TIMx\_ARR - TIMx\_CCR1).
- Let's say you want to build a waveform with a transition from '0' to '1' when a compare match occurs and a transition from '1' to '0' when the counter reaches the auto-reload value. To do this you enable PWM mode 2 by writing OC1M=111 in the TIMx\_CCMR1 register. You can optionally enable the preload registers by writing OC1PE='1' in the TIMx\_CCMR1 register and ARPE in the TIMx\_CR1 register. In this case you have to write the compare value in the TIMx\_CCR1 register, the auto-reload value in the TIMx\_ARR register, generate an update by setting the UG bit and wait for external trigger event on TI2. CC1P is written to '0' in this example.

In our example, the DIR and CMS bits in the TIMx\_CR1 register should be low.

You only want 1 pulse(Single mode), so you write '1' in the OPM bit in the TIMx\_CR1 register to stop the counter at the next update event (when the counter rolls over from the auto-reload value back to 0). When OPM bit in the TIMx\_CR1 register is set to '0', so the Repetitive Mode is selected.

#### **Particular case: OCx fast enable**

In One-pulse mode, the edge detection on Tlx input set the CEN bit which enables the counter. Then the comparison between the counter and the compare value makes the output toggle. But several clock cycles are needed for these operations and it limits the minimum delay  $t_{\text{DELAY min}}$  we can get.

If you want to output a waveform with the minimum delay, you can set the OCxFE bit in the TIMx\_CCMRx register. Then OCxRef (and OCx) are forced in response to the stimulus, without taking in account the comparison. Its new level is the same as if a compare match had occurred. OCxFE acts only if the channel is configured in PWM1 or PWM2 mode.



### 15.4.11 TIM9/12 and external trigger synchronization

The TIM9/12 timers can be synchronized with an external trigger in several modes: Reset mode, Gated mode and Trigger mode.

#### Slave mode: Reset mode

The counter and its prescaler can be reinitialized in response to an event on a trigger input. Moreover, if the URS bit from the TIMx\_CR1 register is low, an update event UEV is generated. Then all the preloaded registers (TIMx\_ARR, TIMx\_CCRx) are updated.

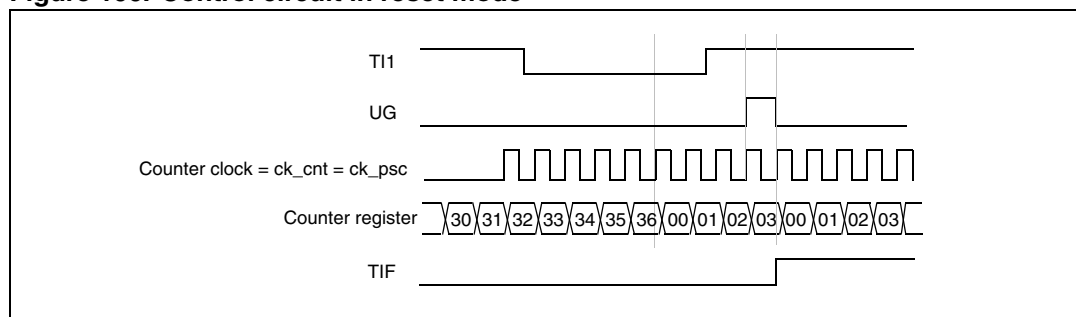
In the following example, the upcounter is cleared in response to a rising edge on TI1 input:

- Configure the channel 1 to detect rising edges on TI1. Configure the input filter duration (in this example, we don't need any filter, so we keep IC1F=0000). The capture prescaler is not used for triggering, so you don't need to configure it. The CC1S bits select the input capture source only, CC1S = 01 in the TIMx\_CCMR1 register. Write CC1P=0 in TIMx\_CCER register to validate the polarity (and detect rising edges only).
- Configure the timer in reset mode by writing SMS=100 in TIMx\_SMCR register. Select TI1 as the input source by writing TS=101 in TIMx\_SMCR register.
- Start the counter by writing CEN=1 in the TIMx\_CR1 register.

The counter starts counting on the internal clock, then behaves normally until TI1 rising edge. When TI1 rises, the counter is cleared and restarts from 0. In the meantime, the trigger flag is set (TIF bit in the TIMx\_SR register) and an interrupt request, or a DMA request can be sent if enabled (depending on the TIE and TDE bits in TIMx\_DIER register).

The following figure shows this behavior when the auto-reload register TIMx\_ARR=0x36. The delay between the rising edge on TI1 and the actual reset of the counter is due to the resynchronization circuit on TI1 input.

**Figure 166. Control circuit in reset mode**



**Slave mode: Gated mode**

The counter can be enabled depending on the level of a selected input.

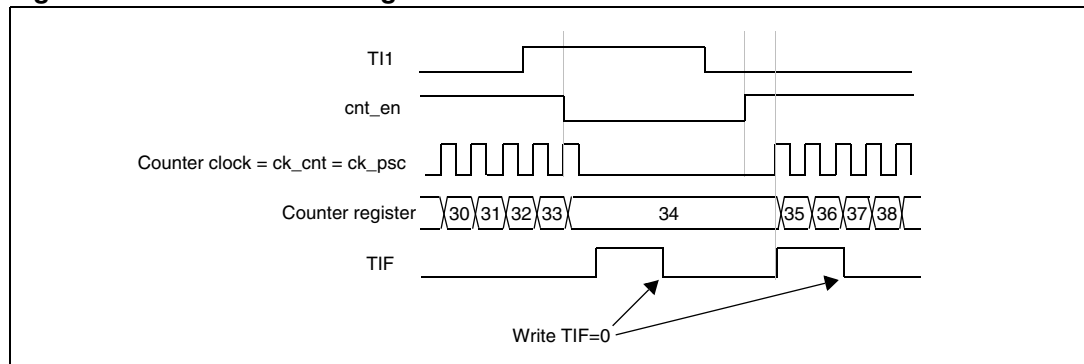
In the following example, the upcounter counts only when TI1 input is low:

- Configure the channel 1 to detect low levels on TI1. Configure the input filter duration (in this example, we don't need any filter, so we keep IC1F=0000). The capture prescaler is not used for triggering, so you don't need to configure it. The CC1S bits select the input capture source only, CC1S=01 in TIMx\_CCMR1 register. Write CC1P=1 in TIMx\_CCER register to validate the polarity (and detect low level only).
- Configure the timer in gated mode by writing SMS=101 in TIMx\_SMCR register. Select TI1 as the input source by writing TS=101 in TIMx\_SMCR register.
- Enable the counter by writing CEN=1 in the TIMx\_CR1 register (in gated mode, the counter doesn't start if CEN=0, whatever is the trigger input level).

The counter starts counting on the internal clock as long as TI1 is low and stops as soon as TI1 becomes high. The TIF flag in the TIMx\_SR register is set both when the counter starts or stops.

The delay between the rising edge on TI1 and the actual stop of the counter is due to the resynchronization circuit on TI1 input.

**Figure 167. Control circuit in gated mode**



### Slave mode: Trigger mode

The counter can start in response to an event on a selected input.

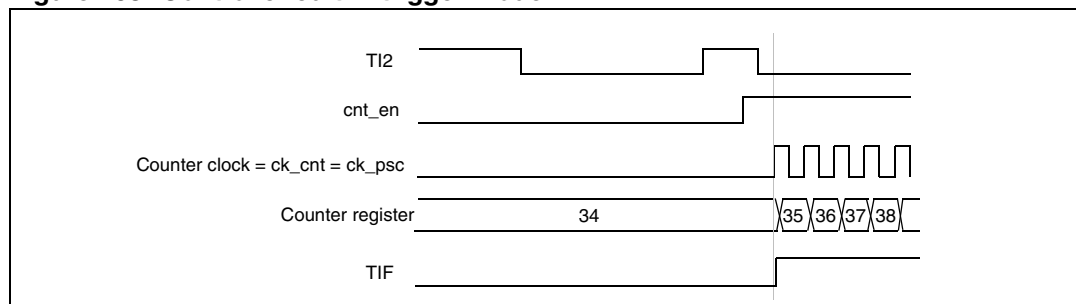
In the following example, the upcounter starts in response to a rising edge on TI2 input:

- Configure the channel 2 to detect rising edges on TI2. Configure the input filter duration (in this example, we don't need any filter, so we keep IC2F=0000). The capture prescaler is not used for triggering, so you don't need to configure it. The CC2S bits are configured to select the input capture source only, CC2S=01 in TIMx\_CCMR1 register. Write CC2P=1 in TIMx\_CCER register to validate the polarity (and detect low level only).
- Configure the timer in trigger mode by writing SMS=110 in TIMx\_SMCR register. Select TI2 as the input source by writing TS=110 in TIMx\_SMCR register.

When a rising edge occurs on TI2, the counter starts counting on the internal clock and the TIF flag is set.

The delay between the rising edge on TI2 and the actual start of the counter is due to the resynchronization circuit on TI2 input.

**Figure 168. Control circuit in trigger mode**



### 15.4.12 Timer synchronization (TIM9/12)

The TIM timers are linked together internally for timer synchronization or chaining. Refer to [Section 14.3.15: Timer synchronization on page 365](#) for details.

### 15.4.13 Debug mode

When the microcontroller enters debug mode (Cortex-M3 core halted), the TIMx counter either continues to work normally or stops, depending on DBG\_TIMx\_STOP configuration bit in DBG module. For more details, refer to [Section 30.16.2: Debug support for timers, watchdog, bxCAN and I2C](#).

## 15.5 TIM9 and TIM12 registers

Refer to [Section 1.1](#) for a list of abbreviations used in register descriptions.

### 15.5.1 TIM9/12 control register 1 (TIMx\_CR1)

Address offset: 0x00

Reset value: 0x0000

15	14	13	12	11	10	9	8	7	6	5	4	3	2	1	0	
Reserved						CKD[1:0]		ARPE	reserved				OPM	URS	UDIS	CEN
						rw	rw	rw					rw	rw	rw	rw

Bits 15:10 Reserved, always read as 0

Bits 9:8 **CKD**: Clock division

This bit-field indicates the division ratio between the timer clock (CK\_INT) frequency and sampling clock used by the digital filters (Tix),

- 00:  $t_{DTS} = t_{CK\_INT}$
- 01:  $t_{DTS} = 2 \times t_{CK\_INT}$
- 10:  $t_{DTS} = 4 \times t_{CK\_INT}$
- 11: Reserved

Bit 7 **ARPE**: Auto-reload preload enable

- 0: TIMx\_ARR register is not buffered.
- 1: TIMx\_ARR register is buffered.

Bits 6:4 Reserved

Bit 3 **OPM**: One-pulse mode

- 0: Counter is not stopped on the update event
- 1: Counter stops counting on the next update event (clearing the CEN bit).

*Note: This bit is not available for the TIM10/11 timers.*

Bit 2 **URS**: Update request source

This bit is set and cleared by software to select the UEV event sources.

0: Any of the following events generates an update interrupt or DMA request if enabled. These events are:

- Counter overflow/underflow
- Setting the UG bit
- Update generation through the slave mode controller

1: Only counter overflow/underflow generates an update interrupt request if enabled.

Bit 1 **UDIS**: Update disable

This bit is set and cleared by software to enable/disable the update event (UEV) generation.

0: UEV enabled. The UEV event is generated by one of the following events:

- Counter overflow/underflow
- Setting the UG bit
- Update generation through the slave mode controller

Buffered registers are then loaded with their preload values.

1: UEV disabled. The UEV is not generated, shadow registers keep their value (ARR, PSC, CCRx). However the counter and the prescaler are reinitialized if the UG bit is set or if a hardware reset is received from the slave mode controller.

Bit 0 **CEN**: Counter enable  
 0: Counter disabled  
 1: Counter enabled

CEN is cleared automatically in one-pulse mode, when an update event occurs.

### 15.5.2 TIM9/12 control register 2 (TIMx\_CR2)

Address offset: 0x04

Reset value: 0x0000

15	14	13	12	11	10	9	8	7	6	5	4	3	2	1	0
Reserved									MMS[2:0]			Reserved			
									rw	rw	rw				

Bits 15:7 Reserved, always read as 0.

Bits 6:4 **MMS**: Master mode selection

These bits are used to select the information to be sent in Master mode to slave timers for synchronization (TRGO). The combination is as follows:

000: **Reset** - the UG bit in the TIMx\_EGR register is used as the trigger output (TRGO). If the reset is generated by the trigger input (slave mode controller configured in reset mode) then the signal on TRGO is delayed compared to the actual reset.

001: **Enable** - the Counter enable signal, CNT\_EN, is used as the trigger output (TRGO). It is useful to start several timers at the same time or to control a window in which a slave timer is enabled. The Counter Enable signal is generated by a logic OR between the CEN control bit and the trigger input when configured in Gated mode.

When the Counter Enable signal is controlled by the trigger input, there is a delay on TRGO, except if the master/slave mode is selected (see the MSM bit description in the TIMx\_SMCR register).

010: **Update** - The update event is selected as the trigger output (TRGO). For instance a master timer can be used as a prescaler for a slave timer.

011: **Compare pulse** - The trigger output sends a positive pulse when the CC1IF flag is to be set (even if it was already high), as soon as a capture or a compare match occurs. (TRGO).

100: **Compare** - OC1REF signal is used as the trigger output (TRGO).

101: **Compare** - OC2REF signal is used as the trigger output (TRGO).

110: Reserved

111: Reserved

Bits 3:0 Reserved, always read as 0.

### 15.5.3 TIM9/12 slave mode control register (TIMx\_SMCR)

Address offset: 0x08

Reset value: 0x0000

15	14	13	12	11	10	9	8	7	6	5	4	3	2	1	0	
Reserved								MSM	TS[2:0]				Res.	SMS[2:0]		
								rw	rw	rw	rw	Res.	rw	rw	rw	

Bits 15:8 Reserved.

Bit 7 **MSM**: Master/Slave mode

0: No action

1: The effect of an event on the trigger input (TRGI) is delayed to allow a perfect synchronization between the current timer and its slaves (through TRGO). It is useful in order to synchronize several timers on a single external event.

Bits 6:4 **TS**: Trigger selection

This bitfield selects the trigger input to be used to synchronize the counter.

000: Internal Trigger 0 (ITR0)

001: Internal Trigger 1 (ITR1)

010: Internal Trigger 2 (ITR2)

011: Internal Trigger 3 (ITR3)

100: TI1 Edge Detector (TI1F\_ED)

101: Filtered Timer Input 1 (TI1FP1)

110: Filtered Timer Input 2 (TI2FP2)

111: Reserved.

See for more details on the meaning of ITRx for each timer.

*Note: These bits must be changed only when they are not used (e.g. when SMS=000) to avoid wrong edge detections at the transition.*

Bit 3 Reserved, always read as 0.

Bits 2:0 **SMS**: Slave mode selection

When external signals are selected, the active edge of the trigger signal (TRGI) is linked to the polarity selected on the external input (see Input control register and Control register descriptions).

000: Slave mode disabled - if CEN = 1 then the prescaler is clocked directly by the internal clock

001: Reserved

010: Reserved

011: Reserved

100: Reset mode - Rising edge of the selected trigger input (TRGI) reinitializes the counter and generates an update of the registers

101: Gated mode - The counter clock is enabled when the trigger input (TRGI) is high. The counter stops (but is not reset) as soon as the trigger becomes low. Counter starts and stops are both controlled

110: Trigger mode - The counter starts on a rising edge of the trigger TRGI (but it is not reset). Only the start of the counter is controlled

111: External clock mode 1 - Rising edges of the selected trigger (TRGI) clock the counter

*Note: The Gated mode must not be used if TI1F\_ED is selected as the trigger input (TS=100). Indeed, TI1F\_ED outputs 1 pulse for each transition on TI1F, whereas the Gated mode checks the level of the trigger signal.*

**Table 87. TIMx internal trigger connection**

Slave TIM	ITR0 (TS = 000)	ITR1 (TS = 001)	ITR2 (TS = 010)	ITR3 (TS = 011)
TIM2	TIM1	TIM8	TIM3	TIM4
TIM3	TIM1	TIM2	TIM5	TIM4
TIM4	TIM1	TIM2	TIM3	TIM8
TIM5	TIM2	TIM3	TIM4	TIM8
TIM9	TIM2	TIM3	TIM10	TIM11
TIM12	TIM4	TIM5	TIM13	TIM14

### 15.5.4 TIM9/12 Interrupt enable register (TIMx\_DIER)

Address offset: 0x0C

Reset value: 0x0000

15	14	13	12	11	10	9	8	7	6	5	4	3	2	1	0
Reserved									TIE	Res			CC2IE	CC1IE	UIE
									rw				rw	rw	rw

Bit 15:7 Reserved, always read as 0.

Bit 6 **TIE**: Trigger interrupt enable  
 0: Trigger interrupt disabled.  
 1: Trigger interrupt enabled.

Bit 5:3 Reserved, always read as 0.

Bit 2 **CC2IE**: Capture/Compare 2 interrupt enable  
 0: CC2 interrupt disabled.  
 1: CC2 interrupt enabled.

*Note: This bit is not available on TIM10/TIM11 and TIM13/TIM14 timers.*

Bit 1 **CC1IE**: Capture/Compare 1 interrupt enable  
 0: CC1 interrupt disabled.  
 1: CC1 interrupt enabled.

Bit 0 **UIE**: Update interrupt enable  
 0: Update interrupt disabled.  
 1: Update interrupt enabled.

### 15.5.5 TIM9/12 status register (TIMx\_SR)

Address offset: 0x10

Reset value: 0x0000

15	14	13	12	11	10	9	8	7	6	5	4	3	2	1	0	
Reserved					CC2OF	CC1OF	Reserved			TIF	Reserved			CC2IF	CC1IF	UIF
					rc_w0	rc_w0				rc_w0				rc_w0	rc_w0	rc_w0

Bit 15:11 Reserved, always read as 0.

Bit 10 **CC2OF**: Capture/compare 2 overcapture flag  
refer to CC1OF description

Bit 9 **CC1OF**: Capture/Compare 1 overcapture flag  
This flag is set by hardware only when the corresponding channel is configured in input capture mode. It is cleared by software by writing it to '0'.  
0: No overcapture has been detected.  
1: The counter value has been captured in TIMx\_CCR1 register while CC1IF flag was already set

Bits 8:7 Reserved, always read as 0.

Bit 6 **TIF**: Trigger interrupt flag  
This flag is set by hardware on trigger event (active edge detected on TRGI input when the slave mode controller is enabled in all modes but gated mode. It is set when the counter starts or stops when gated mode is selected. It is cleared by software.  
0: No trigger event occurred.  
1: Trigger interrupt pending.

Bit 5:3 Reserved, always read as 0

Bit 2 **CC2IF**: Capture/Compare 2 interrupt flag  
refer to CC1IF description

Bit 1 **CC1IF**: Capture/compare 1 interrupt flag  
**If channel CC1 is configured as output:**  
This flag is set by hardware when the counter matches the compare value, with some exception in center-aligned mode (refer to the CMS bits in the TIMx\_CR1 register description). It is cleared by software.  
0: No match.  
1: The content of the counter TIMx\_CNT matches the content of the TIMx\_CCR1 register. When the contents of TIMx\_CCR1 are greater than the contents of TIMx\_ARR, the CC1IF bit goes high on the counter overflow (in upcounting and up/down-counting modes) or underflow (in downcounting mode)  
**If channel CC1 is configured as input:**  
This bit is set by hardware on a capture. It is cleared by software or by reading the TIMx\_CCR1 register.  
0: No input capture occurred.  
1: The counter value has been captured in TIMx\_CCR1 register (An edge has been detected on IC1 which matches the selected polarity).



Bit 0 **UIF**: Update interrupt flag  
 –This bit is set by hardware on an update event. It is cleared by software.  
 0: No update occurred.  
 1: Update interrupt pending. This bit is set by hardware when the registers are updated:  
 –At overflow or underflow (for TIM2 to TIM5) and if UDIS=0 in the TIMx\_CR1 register.  
 –When CNT is reinitialized by software using the UG bit in TIMx\_EGR register, if URS=0 and UDIS=0 in the TIMx\_CR1 register.  
 When CNT is reinitialized by a trigger event (refer to the synchro control register description), if URS=0 and UDIS=0 in the TIMx\_CR1 register.

### 15.5.6 TIM9/12 event generation register (TIMx\_EGR)

Address offset: 0x14

Reset value: 0x0000

15	14	13	12	11	10	9	8	7	6	5	4	3	2	1	0
Reserved									TG	Reserved			CC2G	CC1G	UG
									w				w	w	w

Bits 15:7 Reserved, always read as 0.

Bit 6 **TG**: Trigger generation  
 This bit is set by software in order to generate an event, it is automatically cleared by hardware.  
 0: No action  
 1: The TIF flag is set in the TIMx\_SR register. Related interrupt or DMA transfer can occur if enabled

Bits 5:3 Reserved, always read as 0.

Bit 2 **CC2G**: Capture/compare 2 generation  
 refer to CC1G description

Bit 1 **CC1G**: Capture/compare 1 generation  
 This bit is set by software in order to generate an event, it is automatically cleared by hardware.  
 0: No action  
 1: A capture/compare event is generated on channel 1:  
**If channel CC1 is configured as output:**  
 the CC1IF flag is set, the corresponding interrupt or DMA request is sent if enabled.  
**If channel CC1 is configured as input:**  
 The current counter value is captured in the TIMx\_CCR1 register. The CC1IF flag is set, the corresponding interrupt or DMA request is sent if enabled. The CC1OF flag is set if the CC1IF flag was already high.

Bit 0 **UG**: Update generation  
 This bit can be set by software, it is automatically cleared by hardware.  
 0: No action  
 1: Re-initializes the counter and generates an update of the registers. Note that the prescaler counter is cleared too (the prescaler ratio is not affected). The counter is cleared if DIR=0 (upcounting)

### 15.5.7 TIM9/12 capture/compare mode register 1 (TIMx\_CCMR1)

Address offset: 0x18

Reset value: 0x0000

The channels can be used in input (capture mode) or in output (compare mode). The direction of a channel is defined by configuring the corresponding CCxS bits. All the other bits in this register have different functions in input and output modes. For a given bit, OCxx describes its function when the channel is configured in output mode, ICxx describes its function when the channel is configured in input mode. So you must take care that the same bit can have different meanings for the input stage and the output stage.

15	14	13	12	11	10	9	8	7	6	5	4	3	2	1	0
rw	rw	rw	rw	rw	rw	rw	rw	rw	rw	rw	rw	rw	rw	rw	rw

#### Output compare mode

Bits 14:12 **OC2M[2:0]**: Output compare 2 mode

Bit 11 **OC2PE**: Output compare 2 preload enable

Bit 10 **OC2FE**: Output compare 2 fast enable

Bits 9:8 **CC2S[1:0]**: Capture/Compare 2 selection

This bitfield defines the direction of the channel (input/output) as well as the used input.

00: CC2 channel is configured as output

01: CC2 channel is configured as input, IC2 is mapped on TI2

10: CC2 channel is configured as input, IC2 is mapped on TI1

11: CC2 channel is configured as input, IC2 is mapped on TRC. This mode works only if an internal trigger input is selected through the TS bit (TIMx\_SMCR register)

*Note: The CC2S bits are writable only when the channel is OFF (CC2E = 0 in TIMx\_CCER).*

Bits 6:4 **OC1M**: Output compare 1 mode

These bits define the behavior of the output reference signal OC1REF from which OC1 and OC1N are derived. OC1REF is active high whereas the active levels of OC1 and OC1N depend on the CC1P and CC1NP bits, respectively.

000: Frozen - The comparison between the output compare register TIMx\_CCR1 and the counter TIMx\_CNT has no effect on the outputs.(this mode is used to generate a timing base).

001: Set channel 1 to active level on match. The OC1REF signal is forced high when the TIMx\_CNT counter matches the capture/compare register 1 (TIMx\_CCR1).

010: Set channel 1 to inactive level on match. The OC1REF signal is forced low when the TIMx\_CNT counter matches the capture/compare register 1 (TIMx\_CCR1).

011: Toggle - OC1REF toggles when TIMx\_CNT=TIMx\_CCR1

100: Force inactive level - OC1REF is forced low

101: Force active level - OC1REF is forced high

110: PWM mode 1 - In upcounting, channel 1 is active as long as TIMx\_CNT<TIMx\_CCR1 else it is inactive. In downcounting, channel 1 is inactive (OC1REF=0) as long as TIMx\_CNT>TIMx\_CCR1, else it is active (OC1REF=1)

111: PWM mode 2 - In upcounting, channel 1 is inactive as long as TIMx\_CNT<TIMx\_CCR1 else it is active. In downcounting, channel 1 is active as long as TIMx\_CNT>TIMx\_CCR1 else it is inactive.

*Note: In PWM mode 1 or 2, the OCREF level changes only when the result of the comparison changes or when the output compare mode switches from “frozen” mode to “PWM” mode.*

**Bit 3 OC1PE:** Output compare 1 preload enable

0: Preload register on TIMx\_CCR1 disabled. TIMx\_CCR1 can be written at anytime, the new value is taken into account immediately

1: Preload register on TIMx\_CCR1 enabled. Read/Write operations access the preload register. TIMx\_CCR1 preload value is loaded into the active register at each update event

*Note: The PWM mode can be used without validating the preload register only in one-pulse mode (OPM bit set in the TIMx\_CR1 register). Else the behavior is not guaranteed.*

**Bit 2 OC1FE:** Output compare 1 fast enable

This bit is used to accelerate the effect of an event on the trigger in input on the CC output.  
0: CC1 behaves normally depending on the counter and CCR1 values even when the trigger is ON. The minimum delay to activate the CC1 output when an edge occurs on the trigger input is 5 clock cycles

1: An active edge on the trigger input acts like a compare match on the CC1 output. Then, OC is set to the compare level independently of the result of the comparison. Delay to sample the trigger input and to activate CC1 output is reduced to 3 clock cycles. OC1FE acts only if the channel is configured in PWM1 or PWM2 mode.

**Bits 1:0 CC1S:** Capture/Compare 1 selection

This bitfield defines the direction of the channel (input/output) as well as the used input.

00: CC1 channel is configured as output

01: CC1 channel is configured as input, IC1 is mapped on TI1

10: CC1 channel is configured as input, IC1 is mapped on TI2

11: CC1 channel is configured as input, IC1 is mapped on TRC. This mode works only if an internal trigger input is selected through the TS bit (TIMx\_SMCR register)

*Note: The CC1S bits are writable only when the channel is OFF (CC1E = 0 in TIMx\_CCER).*

## Input capture mode

Bits 15:12 **IC2F**: Input capture 2 filter

Bits 11:10 **IC2PSC[1:0]**: Input capture 2 prescaler

Bits 9:8 **CC2S**: Capture/compare 2 selection

This bitfield defines the direction of the channel (input/output) as well as the used input.

00: CC2 channel is configured as output

01: CC2 channel is configured as input, IC2 is mapped on TI2

10: CC2 channel is configured as input, IC2 is mapped on TI1

11: CC2 channel is configured as input, IC2 is mapped on TRC. This mode works only if an internal trigger input is selected through the TS bit (TIMx\_SMCR register)

*Note: The CC2S bits are writable only when the channel is OFF (CC2E = 0 in TIMx\_CCER).*

Bits 7:4 **IC1F**: Input capture 1 filter

This bitfield defines the frequency used to sample the TI1 input and the length of the digital filter applied to TI1. The digital filter is made of an event counter in which N events are needed to validate a transition on the output:

0000: No filter, sampling is done at  $f_{DTS}$

0001:  $f_{SAMPLING}=f_{CK\_INT}$ , N=2.

0010:  $f_{SAMPLING}=f_{CK\_INT}$ , N=4

0011:  $f_{SAMPLING}=f_{CK\_INT}$ , N=8

0100:  $f_{SAMPLING}=f_{DTS}/2$ , N=6

0101:  $f_{SAMPLING}=f_{DTS}/2$ , N=8

0110:  $f_{SAMPLING}=f_{DTS}/4$ , N=6

0111:  $f_{SAMPLING}=f_{DTS}/4$ , N=8

1000:  $f_{SAMPLING}=f_{DTS}/8$ , N=6

1001:  $f_{SAMPLING}=f_{DTS}/8$ , N=8

1010:  $f_{SAMPLING}=f_{DTS}/16$ , N=5

1011:  $f_{SAMPLING}=f_{DTS}/16$ , N=6

1100:  $f_{SAMPLING}=f_{DTS}/16$ , N=8

1101:  $f_{SAMPLING}=f_{DTS}/32$ , N=5

1110:  $f_{SAMPLING}=f_{DTS}/32$ , N=6

1111:  $f_{SAMPLING}=f_{DTS}/32$ , N=8

Bits 3:2 **IC1PSC**: Input capture 1 prescaler

This bitfield defines the ratio of the prescaler acting on the CC1 input (IC1).

The prescaler is reset as soon as CC1E=0 (TIMx\_CCER register).

00: no prescaler, capture is done each time an edge is detected on the capture input

01: capture is done once every 2 events

10: capture is done once every 4 events

11: capture is done once every 8 events

Bits 1:0 **CC1S**: Capture/Compare 1 selection

This bitfield defines the direction of the channel (input/output) as well as the used input.

00: CC1 channel is configured as output

01: CC1 channel is configured as input, IC1 is mapped on TI1

10: CC1 channel is configured as input, IC1 is mapped on TI2

11: CC1 channel is configured as input, IC1 is mapped on TRC. This mode is working only if an internal trigger input is selected through TS bit (TIMx\_SMCR register)

*Note: The CC1S bits are writable only when the channel is OFF (CC1E = 0 in TIMx\_CCER).*

### 15.5.8 TIM9/12 capture/compare enable register (TIMx\_CCER)

Address offset: 0x20

Reset value: 0x0000

15	14	13	12	11	10	9	8	7	6	5	4	3	2	1	0
Reserved								CC2NP	Res.	CC2P	CC2E	CC1NP	Res.	CC1P	CC1E
								rw		rw	rw	rw		rw	rw

Bits 15:8 Reserved, always read as 0.

Bit 7 **CC2NP**: *Capture/Compare 2 output Polarity.*  
refer to CC1NP description.

Bit 6 Reserved, always read as 0.

Bit 5 **CC2P**: *Capture/Compare 2 output Polarity.*  
refer to CC1P description

Bit 4 **CC2E**: *Capture/Compare 2 output enable.*  
refer to CC1E description

Bit 3 **CC1NP**: *Capture/Compare 1 output Polarity.*  
**CC1 channel configured as output:**  
 CC1NP must be kept cleared in this case.  
**CC1 channel configured as input:**  
 This bit is used in conjunction with CC1P to define TI1FP1/TI2FP1 polarity. refer to CC1P description.

Bit 2 Reserved, always read as 0.

Bit 1 **CC1P**: *Capture/Compare 1 output Polarity.*  
**CC1 channel configured as output:**  
 0: OC1 active high.  
 1: OC1 active low.  
**CC1 channel configured as input:**  
 CC1NP/CC1P bits select TI1FP1 and TI2FP1 polarity for trigger or capture operations.  
 00 : non-inverted/rising edge : circuit is sensitive to TIxFP1 rising edge (capture, trigger in reset, external clock or trigger mode), TIxFP1 is not inverted (trigger in gated mode, encoder mode).  
 01 : inverted/falling edge : circuit is sensitive to TIxFP1 falling edge (capture, trigger in reset, external clock or trigger mode), TIxFP1 is inverted (trigger in gated mode, encoder mode).  
 10 : reserved, do not use this configuration.  
 11: non-inverted/both edges : circuit is sensitive to both TIxFP1 rising and falling edges (capture, trigger in reset, external clock or trigger mode), TIxFP1 is not inverted (trigger in gated mode). This configuration must not be used for encoder mode.

Bit 0 **CC1E**: *Capture/Compare 1 output enable.*  
**CC1 channel configured as output:**  
 0: Off - OC1 is not active.  
 1: On - OC1 signal is output on the corresponding output pin.  
**CC1 channel configured as input:**  
 This bit determines if a capture of the counter value can actually be done into the input capture/compare register 1 (TIMx\_CCR1) or not.  
 0: Capture disabled.  
 1: Capture enabled.

**Table 88. Output control bit for standard OCx channels**

CCxE bit	OCx output state
0	Output disabled (OCx=0, OCx_EN=0)
1	OCx=OCxREF + Polarity, OCx_EN=1

*Note:* The states of the external I/O pins connected to the standard OCx channels depend on the state of the OCx channel and on the GPIO registers.

**15.5.9 TIM9/12 counter (TIMx\_CNT)**

Address offset: 0x24

Reset value: 0x0000 0000

15	14	13	12	11	10	9	8	7	6	5	4	3	2	1	0
CNT[15:0]															
rw	rw	rw	rw	rw	rw	rw	rw	rw	rw	rw	rw	rw	rw	rw	rw

Bits 15:0 **CNT[15:0]**: Counter value

**15.5.10 TIM9/12 prescaler (TIMx\_PSC)**

Address offset: 0x28

Reset value: 0x0000

15	14	13	12	11	10	9	8	7	6	5	4	3	2	1	0
PSC[15:0]															
rw	rw	rw	rw	rw	rw	rw	rw	rw	rw	rw	rw	rw	rw	rw	rw

Bits 15:0 **PSC[15:0]**: Prescaler value

The counter clock frequency CK\_CNT is equal to  $f_{CK\_PSC} / (PSC[15:0] + 1)$ .  
 PSC contains the value to be loaded into the active prescaler register at each update event.

**15.5.11 TIM9/12 auto-reload register (TIMx\_ARR)**

Address offset: 0x2C

Reset value: 0x0000 0000

15	14	13	12	11	10	9	8	7	6	5	4	3	2	1	0
ARR[15:0]															
rw	rw	rw	rw	rw	rw	rw	rw	rw	rw	rw	rw	rw	rw	rw	rw

Bits 15:0 **ARR[15:0]**: Auto-reload value

ARR is the value to be loaded into the actual auto-reload register.  
 Refer to the [Section 15.4.1: Time-base unit on page 394](#) for more details about ARR update and behavior.  
 The counter is blocked while the auto-reload value is null.

### 15.5.12 TIM9/12 capture/compare register 1 (TIMx\_CCR1)

Address offset: 0x34

Reset value: 0x0000 0000

15	14	13	12	11	10	9	8	7	6	5	4	3	2	1	0
CCR1[15:0]															
rw	rw	rw	rw	rw	rw	rw	rw	rw	rw	rw	rw	rw	rw	rw	rw

Bits 15:0 **CCR1[15:0]**: Capture/Compare 1 value

**If channel CC1 is configured as output:**

CCR1 is the value to be loaded into the actual capture/compare 1 register (preload value).

It is loaded permanently if the preload feature is not selected in the TIMx\_CCMR1 register (OC1PE bit). Else the preload value is copied into the active capture/compare 1 register when an update event occurs.

The active capture/compare register contains the value to be compared to the TIMx\_CNT counter and signaled on the OC1 output.

**If channel CC1 is configured as input:**

CCR1 is the counter value transferred by the last input capture 1 event (IC1).

### 15.5.13 TIM9/12 capture/compare register 2 (TIMx\_CCR2)

Address offset: 0x38

Reset value: 0x0000 0000

15	14	13	12	11	10	9	8	7	6	5	4	3	2	1	0
CCR2[15:0]															
rw	rw	rw	rw	rw	rw	rw	rw	rw	rw	rw	rw	rw	rw	rw	rw

Bits 15:0 **CCR2[15:0]**: Capture/Compare 2 value

**If channel CC2 is configured as output:**

CCR2 is the value to be loaded into the actual capture/compare 2 register (preload value).

It is loaded permanently if the preload feature is not selected in the TIMx\_CCMR2 register (OC2PE bit). Else the preload value is copied into the active capture/compare 2 register when an update event occurs.

The active capture/compare register contains the value to be compared to the TIMx\_CNT counter and signalled on the OC2 output.

**If channel CC2 is configured as input:**

CCR2 is the counter value transferred by the last input capture 2 event (IC2).

### 15.5.14 TIM9/12 register map

TIMx registers are mapped as 16-bit addressable registers as described in the tables below:

## 15.6 TIM10/11 and TIM13/14 registers

### 15.6.1 TIM10/11 and TIM13/14 control register 1 (TIMx\_CR1)

Address offset: 0x00

Reset value: 0x0000

15	14	13	12	11	10	9	8	7	6	5	4	3	2	1	0
Reserved						CKD[1:0]		ARPE	Reserved				URS	UDIS	CEN
						rw	rw	rw					rw	rw	rw

Bits 15:10 Reserved, always read as 0.

Bits 9:8 **CKD**: Clock division

This bit-field indicates the division ratio between the timer clock (CK\_INT) frequency and sampling clock used by the digital filters (ETR, TIX),

- 00:  $t_{DTS} = t_{CK\_INT}$
- 01:  $t_{DTS} = 2 \times t_{CK\_INT}$
- 10:  $t_{DTS} = 4 \times t_{CK\_INT}$
- 11: Reserved

Bit 7 **ARPE**: Auto-reload preload enable

- 0: TIMx\_ARR register is not buffered
- 1: TIMx\_ARR register is buffered

Bits 6:3 Reserved, always read as 0.

Bit 2 **URS**: Update request source

This bit is set and cleared by software to select the UEV event sources.

0: Any of the following events generate an update interrupt or DMA request if enabled.

These events can be:

- Counter overflow/underflow
- Setting the UG bit
- Update generation through the slave mode controller

1: Only counter overflow/underflow generates an update interrupt or DMA request if enabled.

Bit 1 **UDIS**: Update disable

This bit is set and cleared by software to enable/disable UEV event generation.

0: UEV enabled. The Update (UEV) event is generated by one of the following events:

- Counter overflow/underflow
- Setting the UG bit
- Update generation through the slave mode controller

Buffered registers are then loaded with their preload values.

1: UEV disabled. The Update event is not generated, shadow registers keep their value (ARR, PSC, CCRx). However the counter and the prescaler are reinitialized if the UG bit is set or if a hardware reset is received from the slave mode controller.



Bit 0 **CEN**: Counter enable  
 0: Counter disabled  
 1: Counter enabled

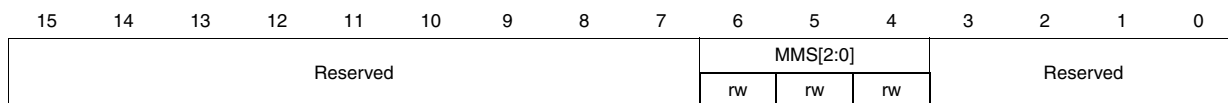
*Note: External clock, gated mode and encoder mode can work only if the CEN bit has been previously set by software. However trigger mode can set the CEN bit automatically by hardware.*

CEN is cleared automatically in one-pulse mode, when an update event occurs.

### 15.6.2 TIMx control register 2 (TIMx\_CR2)

Address offset: 0x04

Reset value: 0x0000



Bits 15:7 Reserved, always read as 0.

Bits 6:4 **MMS**: Master mode selection

These bits allow to select the information to be sent in master mode to slave timers for synchronization (TRGO). The combination is as follows:

000: **Reset** - the UG bit from the TIMx\_EGR register is used as trigger output (TRGO). If the reset is generated by the trigger input (slave mode controller configured in reset mode) then the signal on TRGO is delayed compared to the actual reset.

001: **Enable** - the Counter enable signal, CNT\_EN, is used as trigger output (TRGO). It is useful to start several timers at the same time or to control a window in which a slave timer is enabled. The Counter Enable signal is generated by a logic OR between CEN control bit and the trigger input when configured in gated mode.

When the Counter Enable signal is controlled by the trigger input, there is a delay on TRGO, except if the master/slave mode is selected (see the MSM bit description in TIMx\_SMCR register).

010: **Update** - The update event is selected as trigger output (TRGO). For instance a master timer can then be used as a prescaler for a slave timer.

011: **Compare Pulse** - The trigger output send a positive pulse when the CC1IF flag is to be set (even if it was already high), as soon as a capture or a compare match occurred. (TRGO)

100: **Compare** - OC1REF signal is used as trigger output (TRGO)

101: **Compare** - OC2REF signal is used as trigger output (TRGO)

110: **Compare** - OC3REF signal is used as trigger output (TRGO)

111: **Compare** - OC4REF signal is used as trigger output (TRGO)

Bits 3:0 Reserved, always read as 0

### 15.6.3 TIM10/11 and TIM13/14 DMA/Interrupt enable register (TIMx\_DIER)

Address offset: 0x0C

Reset value: 0x0000

15	14	13	12	11	10	9	8	7	6	5	4	3	2	1	0
Reserved														CC1IE	UIE
														rw	rw

Bits 15:2 Reserved, always read as 0.

Bit 1 **CC1IE**: Capture/Compare 1 interrupt enable

0: CC1 interrupt disabled

1: CC1 interrupt enabled

Bit 0 **UIE**: Update interrupt enable

0: Update interrupt disabled

1: Update interrupt enabled

### 15.6.4 TIM10/11 and TIM13/14 status register (TIMx\_SR)

Address offset: 0x10

Reset value: 0x0000

15	14	13	12	11	10	9	8	7	6	5	4	3	2	1	0
Reserved						CC1OF	Reserved							CC1IF	UIF
						rc_w0								rc_w0	rc_w0

Bit 15:10 Reserved, always read as 0.

Bit 9 **CC1OF**: Capture/Compare 1 overcapture flag

This flag is set by hardware only when the corresponding channel is configured in input capture mode. It is cleared by software by writing it to '0'.

0: No overcapture has been detected.

1: The counter value has been captured in TIMx\_CCR1 register while CC1IF flag was already set

Bits 8:2 Reserved, always read as 0.

Bit 1 **CC1IF**: Capture/compare 1 interrupt flag

**If channel CC1 is configured as output:**

This flag is set by hardware when the counter matches the compare value, with some exception in center-aligned mode (refer to the CMS bits in the TIMx\_CR1 register description). It is cleared by software.

0: No match.

1: The content of the counter TIMx\_CNT matches the content of the TIMx\_CCR1 register.

When the contents of TIMx\_CCR1 are greater than the contents of TIMx\_ARR, the CC1IF bit goes high on the counter overflow (in upcounting and up/down-counting modes) or underflow (in downcounting mode)

**If channel CC1 is configured as input:**

This bit is set by hardware on a capture. It is cleared by software or by reading the TIMx\_CCR1 register.

0: No input capture occurred.

1: The counter value has been captured in TIMx\_CCR1 register (An edge has been detected on IC1 which matches the selected polarity).

Bit 0 **UIF**: Update interrupt flag

- This bit is set by hardware on an update event. It is cleared by software.
  - 0: No update occurred.
  - 1: Update interrupt pending. This bit is set by hardware when the registers are updated:
- At overflow or underflow (for TIM2 to TIM5) and if UDIS=0 in the TIMx\_CR1 register.
- When CNT is reinitialized by software using the UG bit in TIMx\_EGR register, if URS=0 and UDIS=0 in the TIMx\_CR1 register.

When CNT is reinitialized by a trigger event (refer to the synchro control register description), if URS=0 and UDIS=0 in the TIMx\_CR1 register.

### 15.6.5 TIM10/11 and TIM13/14 event generation register (TIMx\_EGR)

Address offset: 0x14

Reset value: 0x0000

15	14	13	12	11	10	9	8	7	6	5	4	3	2	1	0
Reserved														CC1G	UG
														w	w

Bits 15:2 Reserved, always read as 0.

Bit 1 **CC1G**: Capture/compare 1 generation

This bit is set by software in order to generate an event, it is automatically cleared by hardware.

0: No action

1: A capture/compare event is generated on channel 1:

**If channel CC1 is configured as output:**

CC1IF flag is set, Corresponding interrupt or DMA request is sent if enabled.

**If channel CC1 is configured as input:**

The current value of the counter is captured in TIMx\_CCR1 register. The CC1IF flag is set, the corresponding interrupt or DMA request is sent if enabled. The CC1OF flag is set if the CC1IF flag was already high.

Bit 0 **UG**: Update generation

This bit can be set by software, it is automatically cleared by hardware.

0: No action

1: Re-initialize the counter and generates an update of the registers. Note that the prescaler counter is cleared too (anyway the prescaler ratio is not affected). The counter is cleared if the center-aligned mode is selected or if DIR=0 (upcounting), else it takes the auto-reload value (TIMx\_ARR) if DIR=1 (downcounting).

### 15.6.6 TIM10/11 and TIM13/14 capture/compare mode register 1 (TIMx\_CCMR1)

Address offset: 0x18

Reset value: 0x0000

The channels can be used in input (capture mode) or in output (compare mode). The direction of a channel is defined by configuring the corresponding CCxS bits. All the other bits of this register have a different function in input and in output mode. For a given bit, OCxx describes its function when the channel is configured in output, ICxx describes its function when the channel is configured in input. So you must take care that the same bit can have a different meaning for the input stage and for the output stage.

15	14	13	12	11	10	9	8	7	6	5	4	3	2	1	0	
Reserved									OC1M[2:0]			OC1PE	Res.	CC1S[1:0]		
Reserved									IC1F[3:0]			IC1PSC[1:0]				
rw	rw	rw	rw	rw	rw	rw	rw	rw	rw	rw	rw	rw	rw	rw	rw	rw

#### Output compare mode

Bits 15:7 Reserved

Bits 6:4 **OC1M**: Output compare 1 mode

These bits define the behavior of the output reference signal OC1REF from which OC1 and OC1N are derived. OC1REF is active high whereas OC1 and OC1N active level depends on CC1P and CC1NP bits.

000: Frozen - The comparison between the output compare register TIMx\_CCR1 and the counter TIMx\_CNT has no effect on the outputs.

001: Set channel 1 to active level on match. OC1REF signal is forced high when the counter TIMx\_CNT matches the capture/compare register 1 (TIMx\_CCR1).

010: Set channel 1 to inactive level on match. OC1REF signal is forced low when the counter TIMx\_CNT matches the capture/compare register 1 (TIMx\_CCR1).

011: Toggle - OC1REF toggles when TIMx\_CNT=TIMx\_CCR1.

100: Force inactive level - OC1REF is forced low.

101: Force active level - OC1REF is forced high.

110: PWM mode 1 - In upcounting, channel 1 is active as long as TIMx\_CNT < TIMx\_CCR1 else inactive. In downcounting, channel 1 is inactive (OC1REF=0) as long as TIMx\_CNT > TIMx\_CCR1 else active (OC1REF=1).

111: PWM mode 2 - In upcounting, channel 1 is inactive as long as TIMx\_CNT < TIMx\_CCR1 else active. In downcounting, channel 1 is active as long as TIMx\_CNT > TIMx\_CCR1 else inactive.

*Note: 1: These bits can not be modified as long as LOCK level 3 has been programmed (LOCK bits in TIMx\_BDTR register) and CC1S=00 (the channel is configured in output).*

*2: In PWM mode 1 or 2, the OCREF level changes only when the result of the comparison changes or when the output compare mode switches from "frozen" mode to "PWM" mode.*

Bit 3 **OC1PE**: Output compare 1 preload enable

0: Preload register on TIMx\_CCR1 disabled. TIMx\_CCR1 can be written at anytime, the new value is taken in account immediately.

1: Preload register on TIMx\_CCR1 enabled. Read/Write operations access the preload register. TIMx\_CCR1 preload value is loaded in the active register at each update event.

*Note: 1: These bits can not be modified as long as LOCK level 3 has been programmed (LOCK bits in TIMx\_BDTR register) and CC1S=00 (the channel is configured in output).*

*2: The PWM mode can be used without validating the preload register only in one-pulse mode (OPM bit set in TIMx\_CR1 register). Else the behavior is not guaranteed.*

Bit 2 Reserved

Bits 1:0 **CC1S**: Capture/Compare 1 selection

This bit-field defines the direction of the channel (input/output) as well as the used input.

00: CC1 channel is configured as output.

01: CC1 channel is configured as input, IC1 is mapped on TI1.

10: CC1 channel is configured as input, IC1 is mapped on TI2

11: CC1 channel is configured as input, IC1 is mapped on TRC. This mode is working only if an internal trigger input is selected through TS bit (TIMx\_SMCR register)

*Note: CC1S bits are writable only when the channel is OFF (CC1E = 0 in TIMx\_CCER).*

## Input capture mode

Bits 15:8 Reserved

Bits 7:4 **IC1F**: Input capture 1 filter

This bit-field defines the frequency used to sample TI1 input and the length of the digital filter applied to TI1. The digital filter is made of an event counter in which N events are needed to validate a transition on the output:

0000: No filter, sampling is done at  $f_{DTS}$   
 0001:  $f_{SAMPLING}=f_{CK\_INT}$ , N=2  
 0010:  $f_{SAMPLING}=f_{CK\_INT}$ , N=4  
 0011:  $f_{SAMPLING}=f_{CK\_INT}$ , N=8  
 0100:  $f_{SAMPLING}=f_{DTS}/2$ , N=6  
 0101:  $f_{SAMPLING}=f_{DTS}/2$ , N=8  
 0110:  $f_{SAMPLING}=f_{DTS}/4$ , N=6  
 0111:  $f_{SAMPLING}=f_{DTS}/4$ , N=8  
 1000:  $f_{SAMPLING}=f_{DTS}/8$ , N=6  
 1001:  $f_{SAMPLING}=f_{DTS}/8$ , N=8  
 1010:  $f_{SAMPLING}=f_{DTS}/16$ , N=5  
 1011:  $f_{SAMPLING}=f_{DTS}/16$ , N=6  
 1100:  $f_{SAMPLING}=f_{DTS}/16$ , N=8  
 1101:  $f_{SAMPLING}=f_{DTS}/32$ , N=5  
 1110:  $f_{SAMPLING}=f_{DTS}/32$ , N=6  
 1111:  $f_{SAMPLING}=f_{DTS}/32$ , N=8

*Note:* In current silicon revision,  $f_{DTS}$  is replaced in the formula by  $CK\_INT$  when  $ICx[3:0]=1, 2$  or  $3$ .

Bits 3:2 **IC1PSC**: Input capture 1 prescaler

This bit-field defines the ratio of the prescaler acting on CC1 input (IC1).

The prescaler is reset as soon as  $CC1E=0$  (TIMx\_CCER register).

00: no prescaler, capture is done each time an edge is detected on the capture input  
 01: capture is done once every 2 events  
 10: capture is done once every 4 events  
 11: capture is done once every 8 events

Bits 1:0 **CC1S**: Capture/Compare 1 selection

This bit-field defines the direction of the channel (input/output) as well as the used input.

00: CC1 channel is configured as output  
 01: CC1 channel is configured as input, IC1 is mapped on TI1  
 10: CC1 channel is configured as input, IC1 is mapped on TI2  
 11: CC1 channel is configured as input, IC1 is mapped on TRC. This mode is working only if an internal trigger input is selected through TS bit (TIMx\_SMCR register)

*Note:* CC1S bits are writable only when the channel is OFF ( $CC1E = 0$  in TIMx\_CCER).

### 15.6.7 TIM10/11 and TIM13/14 capture/compare enable register (TIMx\_CCER)

Address offset: 0x20

Reset value: 0x0000

15	14	13	12	11	10	9	8	7	6	5	4	3	2	1	0
Reserved												CC1NP	Res.	CC1P	CC1E
												rw		rw	rw

Bits 15:4 Reserved, always read as 0.

Bit 3 **CC1NP**: *Capture/Compare 1 output Polarity.*

**CC1 channel configured as output:**

CC1NP must be kept cleared in this case.

**CC1 channel configured as input:**

This bit is used in conjunction with CC1P to define TI1FP1/TI2FP1 polarity. refer to CC1P description.

Bit 2 Reserved, always read as 0.

Bit 1 **CC1P**: *Capture/Compare 1 output Polarity.*

**CC1 channel configured as output:**

0: OC1 active high

1: OC1 active low

**CC1 channel configured as input:**

CC1NP/CC1P bits select TI1FP1 and TI2FP1 polarity for trigger or capture operations.

00 : non-inverted/rising edge : circuit is sensitive to TIxFP1 rising edge (capture, trigger in reset, external clock or trigger mode), TIxFP1 is not inverted (trigger in gated mode, encoder mode).

01 : inverted/falling edge : circuit is sensitive to TIxFP1 falling edge (capture, trigger in reset, external clock or trigger mode), TIxFP1 is inverted (trigger in gated mode, encoder mode)

10 : reserved, do not use this configuration.

11: non-inverted/both edges : circuit is sensitive to both TIxFP1 rising and falling edges (capture, trigger in reset, external clock or trigger mode), TIxFP1 is not inverted (trigger in gated mode). This configuration must not be used for encoder mode.

Bit 0 **CC1E**: *Capture/Compare 1 output enable.*

**CC1 channel configured as output:**

0: Off - OC1 is not active

1: On - OC1 signal is output on the corresponding output pin

**CC1 channel configured as input:**

This bit determines if a capture of the counter value can actually be done into the input capture/compare register 1 (TIMx\_CCR1) or not.

0: Capture disabled

1: Capture enabled

**Table 90. Output control bit for standard OCx channels**

CCxE bit	OCx output state
0	Output Disabled (OCx=0, OCx_EN=0)
1	OCx=OCxREF + Polarity, OCx_EN=1

*Note: The state of the external I/O pins connected to the standard OCx channels depends on the OCx channel state and the GPIO registers.*

### 15.6.8 TIM10/11 and TIM13/14 counter (TIMx\_CNT)

Address offset: 0x24

Reset value: 0x0000

15	14	13	12	11	10	9	8	7	6	5	4	3	2	1	0
CNT[15:0]															
rw	rw	rw	rw	rw	rw	rw	rw	rw	rw	rw	rw	rw	rw	rw	rw

Bits 15:0 **CNT[15:0]**: Counter value

### 15.6.9 TIM10/11 and TIM13/14 prescaler (TIMx\_PSC)

Address offset: 0x28

Reset value: 0x0000

15	14	13	12	11	10	9	8	7	6	5	4	3	2	1	0
PSC[15:0]															
rw	rw	rw	rw	rw	rw	rw	rw	rw	rw	rw	rw	rw	rw	rw	rw

Bits 15:0 **PSC[15:0]**: Prescaler value

The counter clock frequency CK\_CNT is equal to  $f_{CK\_PSC} / (PSC[15:0] + 1)$ .

PSC contains the value to be loaded in the active prescaler register at each update event.

### 15.6.10 TIM10/11 and TIM13/14 auto-reload register (TIMx\_ARR)

Address offset: 0x2C

Reset value: 0x0000

15	14	13	12	11	10	9	8	7	6	5	4	3	2	1	0
ARR[15:0]															
rw	rw	rw	rw	rw	rw	rw	rw	rw	rw	rw	rw	rw	rw	rw	rw

Bits 15:0 **ARR[15:0]**: Auto-reload value

ARR is the value to be loaded in the actual auto-reload register.

Refer to the [Section 15.4.1: Time-base unit on page 394](#) for more details about ARR update and behavior.

The counter is blocked while the auto-reload value is null.





**Table 91. TIM10/11/13/14 register map and reset values (continued)**

Offset	Register	31	30	29	28	27	26	25	24	23	22	21	20	19	18	17	16	15	14	13	12	11	10	9	8	7	6	5	4	3	2	1	0		
0x28	<b>TIMx_PSC</b> Reset value	Reserved																PSC[15:0] 0   0																	
0x2C	<b>TIMx_ARR</b> Reset value	Reserved																ARR[15:0] 0   0																	
0x30	Reserved																																		
0x34	<b>TIMx_CCR1</b> Reset value	Reserved																CCR1[15:0] 0   0																	
0x38 to 0x4C	Reserved																																		
0x50	<b>TIMx_OR</b> Reset value	Not available																																	

## 16 Basic timers (TIM6&TIM7)

**Low-density devices** are STM32F101xx, STM32F102xx and STM32F103xx microcontrollers where the Flash memory density ranges between 16 and 32 Kbytes.

**Medium-density devices** are STM32F101xx, STM32F102xx and STM32F103xx microcontrollers where the Flash memory density ranges between 64 and 128 Kbytes.

**High-density devices** are STM32F101xx and STM32F103xx microcontrollers where the Flash memory density ranges between 256 and 512 Kbytes.

**XL-density devices** are STM32F101xx and STM32F103xx microcontrollers where the Flash memory density ranges between 768 Kbytes and 1 Mbyte.

**Connectivity line devices** are STM32F105xx and STM32F107xx microcontrollers.

This section applies to high-density and XL-density STM32F101xx and STM32F103xx devices, and to connectivity line devices only.

### 16.1 TIM6&TIM7 introduction

The basic timers TIM6 and TIM7 consist of a 16-bit auto-reload counter driven by a programmable prescaler.

They may be used as generic timers for time-base generation but they are also specifically used to drive the digital-to-analog converter (DAC). In fact, the timers are internally connected to the DAC and are able to drive it through their trigger outputs.

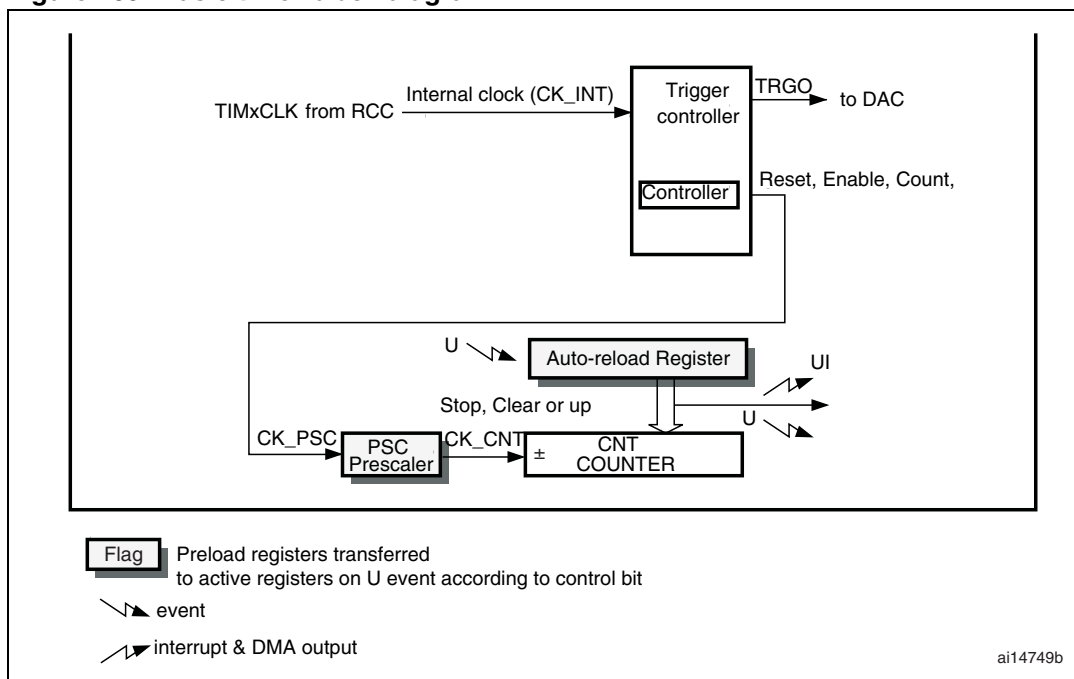
The timers are completely independent, and do not share any resources.

### 16.2 TIM6&TIM7 main features

Basic timer (TIM6&TIM7) features include:

- 16-bit auto-reload upcounter
- 16-bit programmable prescaler used to divide (also “on the fly”) the counter clock frequency by any factor between 1 and 65535
- Synchronization circuit to trigger the DAC
- Interrupt/DMA generation on the update event: counter overflow

Figure 169. Basic timer block diagram



## 16.3 TIM6&TIM7 functional description

### 16.3.1 Time-base unit

The main block of the programmable timer is a 16-bit upcounter with its related auto-reload register. The counter clock can be divided by a prescaler.

The counter, the auto-reload register and the prescaler register can be written or read by software. This is true even when the counter is running.

The time-base unit includes:

- Counter Register (TIMx\_CNT)
- Prescaler Register (TIMx\_PSC)
- Auto-Reload Register (TIMx\_ARR)

The auto-reload register is preloaded. The preload register is accessed each time an attempt is made to write or read the auto-reload register. The contents of the preload register are transferred into the shadow register permanently or at each update event UEV, depending on the auto-reload preload enable bit (ARPE) in the TIMx\_CR1 register. The update event is sent when the counter reaches the overflow value and if the UDIS bit equals 0 in the TIMx\_CR1 register. It can also be generated by software. The generation of the update event is described in detail for each configuration.

The counter is clocked by the prescaler output CK\_CNT, which is enabled only when the counter enable bit (CEN) in the TIMx\_CR1 register is set.

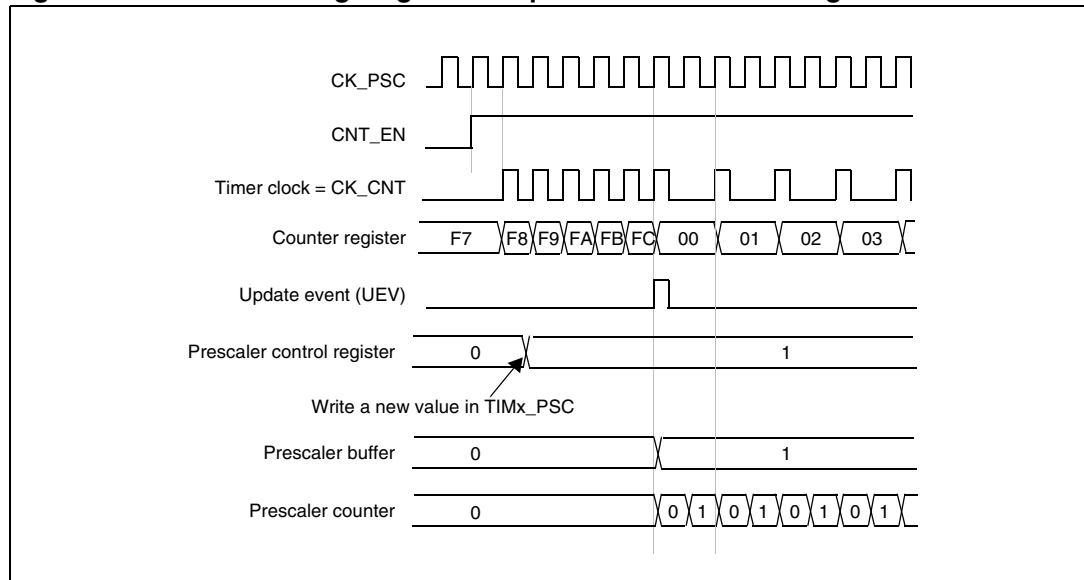
Note that the actual counter enable signal CNT\_EN is set 1 clock cycle after CEN.

### Prescaler description

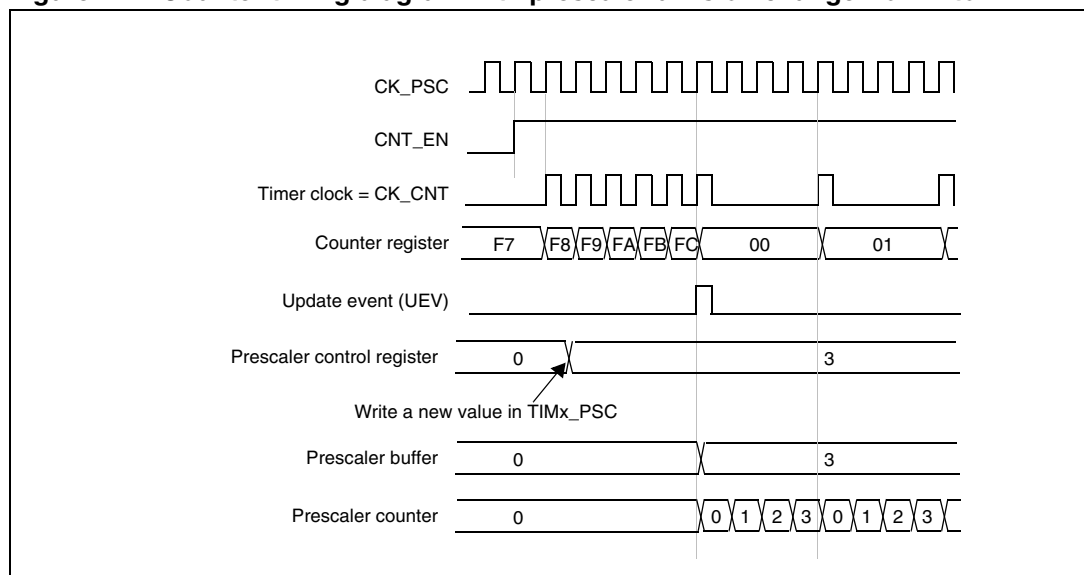
The prescaler can divide the counter clock frequency by any factor between 1 and 65536. It is based on a 16-bit counter controlled through a 16-bit register (in the TIMx\_PSC register). It can be changed on the fly as the TIMx\_PSC control register is buffered. The new prescaler ratio is taken into account at the next update event.

Figure 170 and Figure 171 give some examples of the counter behavior when the prescaler ratio is changed on the fly.

**Figure 170. Counter timing diagram with prescaler division change from 1 to 2**



**Figure 171. Counter timing diagram with prescaler division change from 1 to 4**



### 16.3.2 Counting mode

The counter counts from 0 to the auto-reload value (contents of the TIMx\_ARR register), then restarts from 0 and generates a counter overflow event.

An update event can be generate at each counter overflow or by setting the UG bit in the TIMx\_EGR register (by software or by using the slave mode controller).

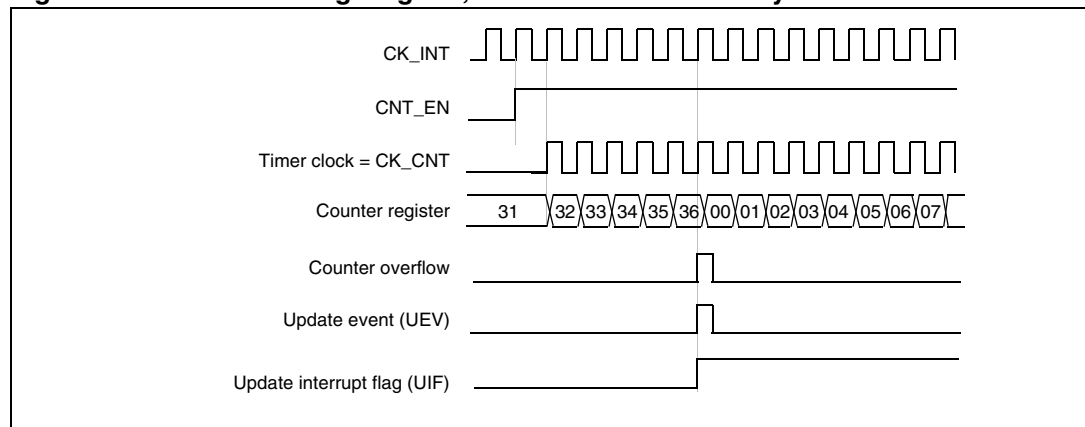
The UEV event can be disabled by software by setting the UDIS bit in the TIMx\_CR1 register. This avoids updating the shadow registers while writing new values into the preload registers. In this way, no update event occurs until the UDIS bit has been written to 0, however, the counter and the prescaler counter both restart from 0 (but the prescale rate does not change). In addition, if the URS (update request selection) bit in the TIMx\_CR1 register is set, setting the UG bit generates an update event UEV, but the UIF flag is not set (so no interrupt or DMA request is sent).

When an update event occurs, all the registers are updated and the update flag (UIF bit in the TIMx\_SR register) is set (depending on the URS bit):

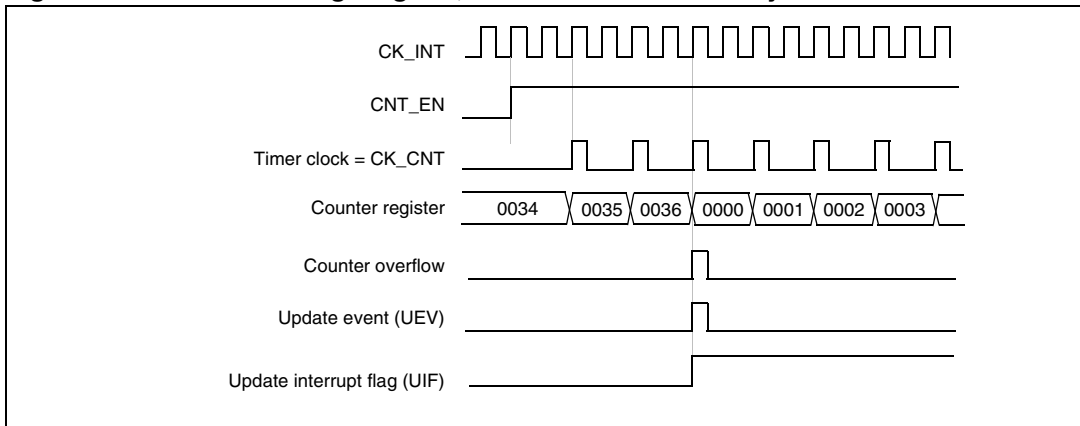
- The buffer of the prescaler is reloaded with the preload value (contents of the TIMx\_PSC register)
- The auto-reload shadow register is updated with the preload value (TIMx\_ARR)

The following figures show some examples of the counter behavior for different clock frequencies when TIMx\_ARR = 0x36.

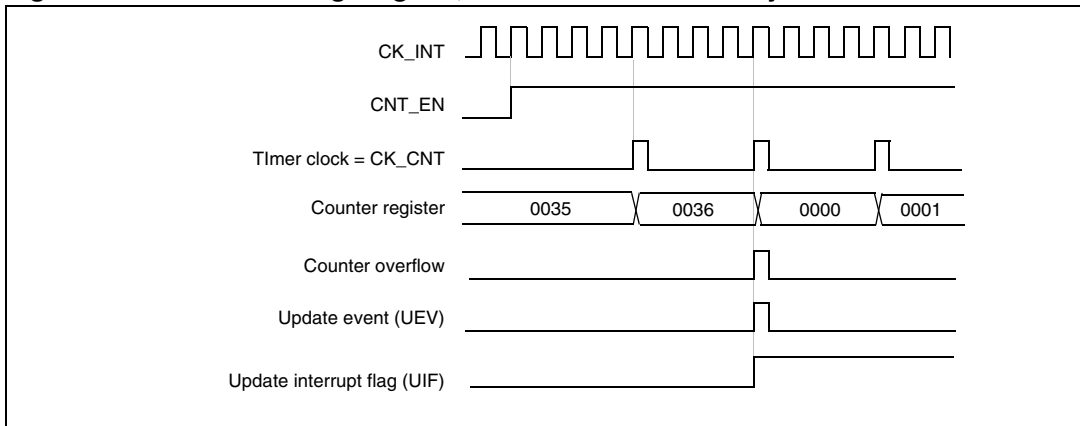
**Figure 172. Counter timing diagram, internal clock divided by 1**



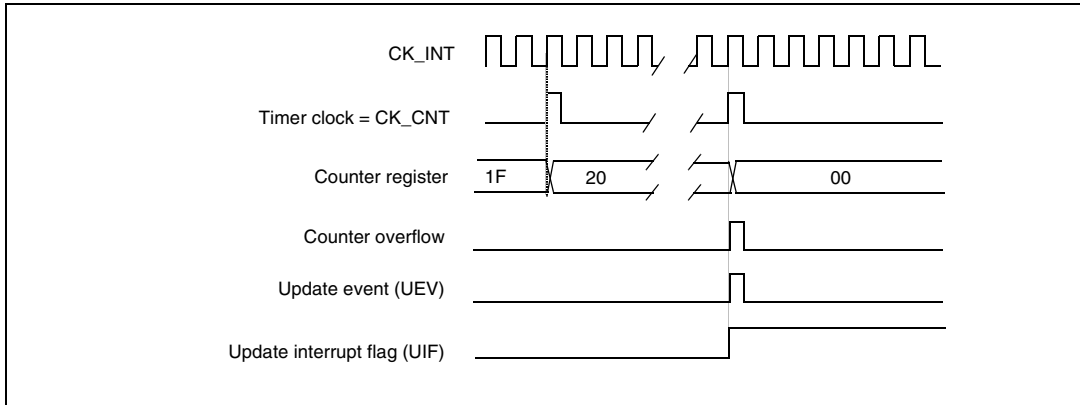
**Figure 173. Counter timing diagram, internal clock divided by 2**



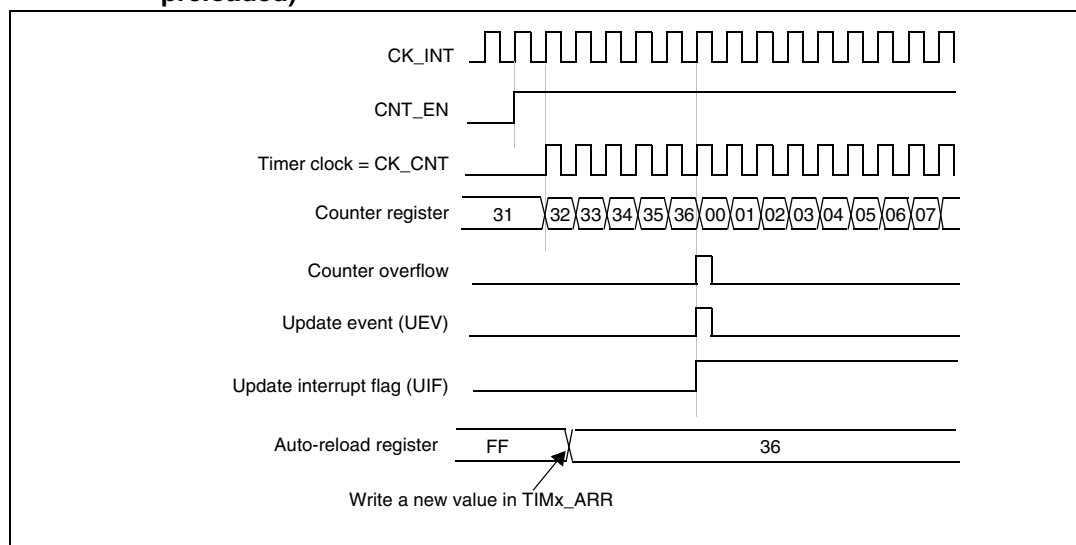
**Figure 174. Counter timing diagram, internal clock divided by 4**



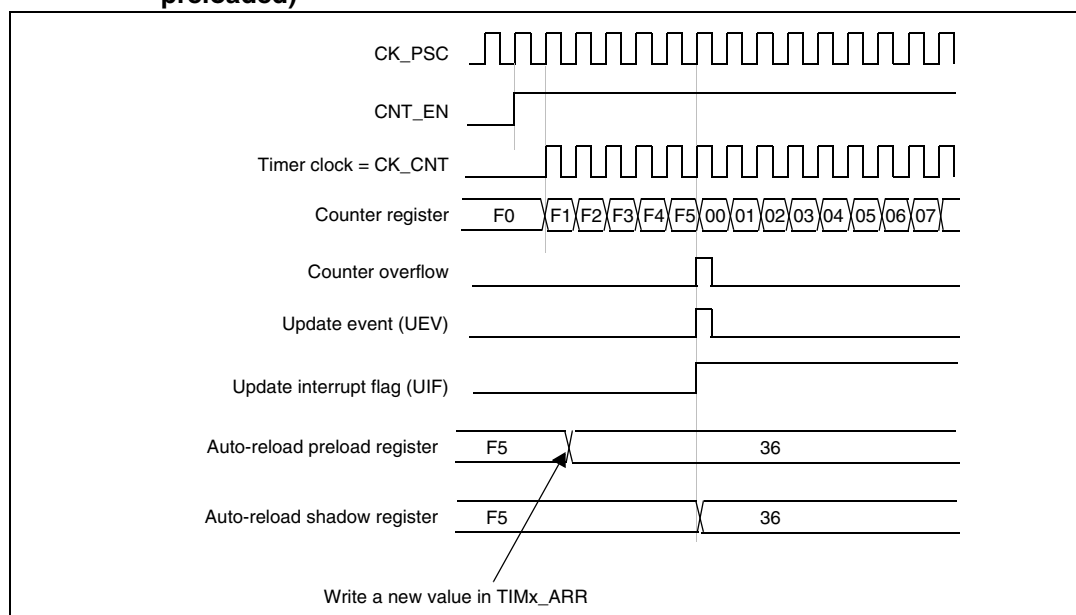
**Figure 175. Counter timing diagram, internal clock divided by N**



**Figure 176. Counter timing diagram, update event when ARPE = 0 (TIMx\_ARR not preloaded)**



**Figure 177. Counter timing diagram, update event when ARPE=1 (TIMx\_ARR preloaded)**



### 16.3.3 Clock source

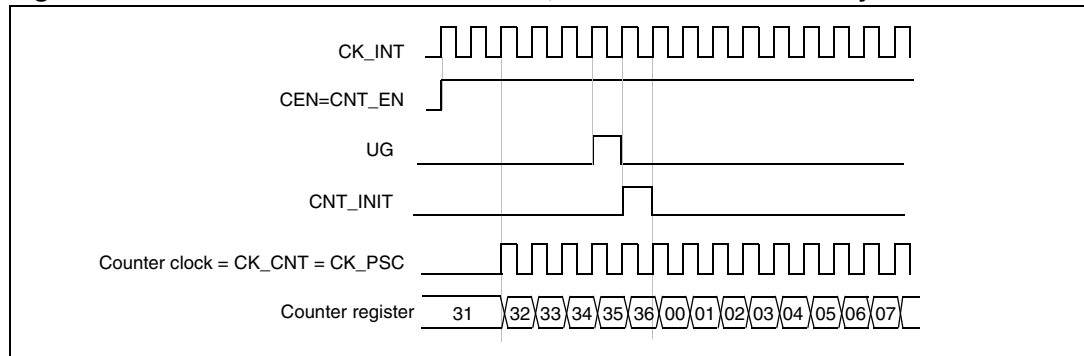
The counter clock is provided by the Internal clock (CK\_INT) source.

The CEN (in the TIMx\_CR1 register) and UG bits (in the TIMx\_EGR register) are actual control bits and can be changed only by software (except for UG that remains cleared automatically). As soon as the CEN bit is written to 1, the prescaler is clocked by the internal clock CK\_INT.

Figure 178 shows the behavior of the control circuit and the upcounter in normal mode, without prescaler.



Figure 178. Control circuit in normal mode, internal clock divided by 1



### 16.3.4 Debug mode

When the microcontroller enters the debug mode (Cortex-M3 core - halted), the TIMx counter either continues to work normally or stops, depending on the DBG\_TIMx\_STOP configuration bit in the DBG module. For more details, refer to [Section 30.16.2: Debug support for timers, watchdog, bxCAN and I2C](#).

## 16.4 TIM6&TIM7 registers

Refer to [Section 1.1 on page 40](#) for a list of abbreviations used in register descriptions.

The peripheral registers can be accessed by half-words (16-bit) or words (32-bit).

### 16.4.1 TIM6&TIM7 control register 1 (TIMx\_CR1)

Address offset: 0x00

Reset value: 0x0000

15	14	13	12	11	10	9	8	7	6	5	4	3	2	1	0	
Reserved								ARPE	Reserved				OPM	URS	UDIS	CEN
								rw					rw	rw	rw	rw

Bits 15:8 Reserved, always read as 0

Bit 7 **ARPE**: Auto-reload preload enable

- 0: TIMx\_ARR register is not buffered.
- 1: TIMx\_ARR register is buffered.

Bits 6:4 Reserved, always read as 0

Bit 3 **OPM**: One-pulse mode

- 0: Counter is not stopped at update event
- 1: Counter stops counting at the next update event (clearing the CEN bit).

**Bit 2 URS:** Update request source

This bit is set and cleared by software to select the UEV event sources.

0: Any of the following events generates an update interrupt or DMA request if enabled.

These events can be:

- Counter overflow/underflow
- Setting the UG bit
- Update generation through the slave mode controller

1: Only counter overflow/underflow generates an update interrupt or DMA request if enabled.

**Bit 1 UDIS:** Update disable

This bit is set and cleared by software to enable/disable UEV event generation.

0: UEV enabled. The Update (UEV) event is generated by one of the following events:

- Counter overflow/underflow
- Setting the UG bit
- Update generation through the slave mode controller

Buffered registers are then loaded with their preload values.

1: UEV disabled. The Update event is not generated, shadow registers keep their value (ARR, PSC). However the counter and the prescaler are reinitialized if the UG bit is set or if a hardware reset is received from the slave mode controller.

**Bit 0 CEN:** Counter enable

0: Counter disabled

1: Counter enabled

*Note: Gated mode can work only if the CEN bit has been previously set by software. However trigger mode can set the CEN bit automatically by hardware.*

CEN is cleared automatically in one-pulse mode, when an update event occurs.

### 16.4.2 TIM6&TIM7 control register 2 (TIMx\_CR2)

Address offset: 0x04

Reset value: 0x0000

15	14	13	12	11	10	9	8	7	6	5	4	3	2	1	0
Reserved									MMS[2:0]			Reserved			
									rw	rw	rw				

Bits 15:7 Reserved, always read as 0.

Bits 6:4 **MMS**: Master mode selection

These bits are used to select the information to be sent in master mode to slave timers for synchronization (TRGO). The combination is as follows:

000: **Reset** - the UG bit from the TIMx\_EGR register is used as a trigger output (TRGO). If reset is generated by the trigger input (slave mode controller configured in reset mode) then the signal on TRGO is delayed compared to the actual reset.

001: **Enable** - the Counter enable signal, CNT\_EN, is used as a trigger output (TRGO). It is useful to start several timers at the same time or to control a window in which a slave timer is enabled. The Counter Enable signal is generated by a logic OR between CEN control bit and the trigger input when configured in gated mode.

When the Counter Enable signal is controlled by the trigger input, there is a delay on TRGO, except if the master/slave mode is selected (see the MSM bit description in the TIMx\_SMCR register).

010: **Update** - The update event is selected as a trigger output (TRGO). For instance a master timer can then be used as a prescaler for a slave timer.

Bits 3:0 Reserved, always read as 0

### 16.4.3 TIM6&TIM7 DMA/Interrupt enable register (TIMx\_DIER)

Address offset: 0x0C

Reset value: 0x0000

15	14	13	12	11	10	9	8	7	6	5	4	3	2	1	0
Reserved							UDE	Reserved							UIE
							rw								rw

Bit 15:9 Reserved, always read as 0.

Bit 8 **UDE**: Update DMA request enable

0: Update DMA request disabled.

1: Update DMA request enabled.

Bit 7:1 Reserved, always read as 0.

Bit 0 **UIE**: Update interrupt enable

0: Update interrupt disabled.

1: Update interrupt enabled.

### 16.4.4 TIM6&TIM7 status register (TIMx\_SR)

Address offset: 0x10

Reset value: 0x0000

15	14	13	12	11	10	9	8	7	6	5	4	3	2	1	0
Reserved															UIF
															rc_w0

Bits 15:1 Reserved, always read as 0.

Bit 0 **UIF**: Update interrupt flag

This bit is set by hardware on an update event. It is cleared by software.

0: No update occurred.

1: Update interrupt pending. This bit is set by hardware when the registers are updated:

- At overflow or underflow regarding the repetition counter value and if UDIS = 0 in the TIMx\_CR1 register.

- When CNT is reinitialized by software using the UG bit in the TIMx\_EGR register, if URS = 0 and UDIS = 0 in the TIMx\_CR1 register.

### 16.4.5 TIM6&TIM7 event generation register (TIMx\_EGR)

Address offset: 0x14

Reset value: 0x0000

15	14	13	12	11	10	9	8	7	6	5	4	3	2	1	0
Reserved															UG
															w

Bits 15:1 Reserved, always read as 0.

Bit 0 **UG**: Update generation

This bit can be set by software, it is automatically cleared by hardware.

0: No action.

1: Re-initializes the timer counter and generates an update of the registers. Note that the prescaler counter is cleared too (but the prescaler ratio is not affected).

### 16.4.6 TIM6&TIM7 counter (TIMx\_CNT)

Address offset: 0x24

Reset value: 0x0000

15	14	13	12	11	10	9	8	7	6	5	4	3	2	1	0
CNT[15:0]															
rw	rw	rw	rw	rw	rw	rw	rw	rw	rw	rw	rw	rw	rw	rw	rw

Bits 15:0 **CNT[15:0]**: Counter value

### 16.4.7 TIM6&TIM7 prescaler (TIMx\_PSC)

Address offset: 0x28

Reset value: 0x0000

15	14	13	12	11	10	9	8	7	6	5	4	3	2	1	0
PSC[15:0]															
rw	rw	rw	rw	rw	rw	rw	rw	rw	rw	rw	rw	rw	rw	rw	rw

Bits 15:0 **PSC[15:0]**: Prescaler value

The counter clock frequency CK\_CNT is equal to  $f_{CK\_PSC} / (PSC[15:0] + 1)$ .

PSC contains the value to be loaded into the active prescaler register at each update event.

### 16.4.8 TIM6&TIM7 auto-reload register (TIMx\_ARR)

Address offset: 0x2C

Reset value: 0x0000

15	14	13	12	11	10	9	8	7	6	5	4	3	2	1	0
ARR[15:0]															
rw	rw	rw	rw	rw	rw	rw	rw	rw	rw	rw	rw	rw	rw	rw	rw

Bits 15:0 **ARR[15:0]**: Prescaler value

ARR is the value to be loaded into the actual auto-reload register.

Refer to [Section 16.3.1: Time-base unit on page 436](#) for more details about ARR update and behavior.

The counter is blocked while the auto-reload value is null.

### 16.4.9 TIM6&TIM7 register map

TIMx registers are mapped as 16-bit addressable registers as described in the table below:

**Table 92. TIM6&TIM7 register map and reset values**

Offset	Register	31	30	29	28	27	26	25	24	23	22	21	20	19	18	17	16	15	14	13	12	11	10	9	8	7	6	5	4	3	2	1	0				
0x00	TIMx_CR1 Reset value	Reserved																							0	ARPE	Reserved			0	OPM	0	URS	0	UDIS	0	CEN
0x04	TIMx_CR2 Reset value	Reserved													MMS[2:0]			Reserved																			
0x08	Reserved																																				
0x0C	TIMx_DIER Reset value	Reserved																							0	UDE	Reserved			0	UIE						
0x10	TIMx_SR Reset value	Reserved																										0	UIF								
0x14	TIMx_EGR Reset value	Reserved																										0	UG								
0x18	Reserved																																				
0x1C	Reserved																																				
0x20	Reserved																																				
0x24	TIMx_CNT Reset value	Reserved													CNT[15:0]																						
		0   0																																			
0x28	TIMx_PSC Reset value	Reserved													PSC[15:0]																						
		0   0																																			
0x2C	TIMx_ARR Reset value	Reserved													ARR[15:0]																						
		0   0																																			

Refer to *Register boundary addresses* table.

## 17 Real-time clock (RTC)

**Low-density devices** are STM32F101xx, STM32F102xx and STM32F103xx microcontrollers where the Flash memory density ranges between 16 and 32 Kbytes.

**Medium-density devices** are STM32F101xx, STM32F102xx and STM32F103xx microcontrollers where the Flash memory density ranges between 64 and 128 Kbytes.

**High-density devices** are STM32F101xx and STM32F103xx microcontrollers where the Flash memory density ranges between 256 and 512 Kbytes.

**XL-density devices** are STM32F101xx and STM32F103xx microcontrollers where the Flash memory density ranges between 768 Kbytes and 1 Mbyte.

**Connectivity line devices** are STM32F105xx and STM32F107xx microcontrollers.

This section applies to the whole STM32F10xxx family, unless otherwise specified.

### 17.1 RTC introduction

The real-time clock is an independent timer. The RTC provides a set of continuously running counters which can be used, with suitable software, to provide a clock-calendar function. The counter values can be written to set the current time/date of the system.

The RTC core and clock configuration (RCC\_BDCR register) are in the Backup domain, which means that RTC setting and time are kept after reset or wakeup from Standby mode.

After reset, access to the Backup registers and RTC is disabled and the Backup domain (BKP) is protected against possible parasitic write access. To enable access to the Backup registers and the RTC, proceed as follows:

- enable the power and backup interface clocks by setting the PWREN and BKPEN bits in the RCC\_APB1ENR register
- set the DBP bit the Power Control Register (PWR\_CR) to enable access to the Backup registers and RTC.

## 17.2 RTC main features

- Programmable prescaler: division factor up to  $2^{20}$
- 32-bit programmable counter for long-term measurement
- Two separate clocks: PCLK1 for the APB1 interface and RTC clock (must be at least four times slower than the PCLK1 clock)
- The RTC clock source could be any of the following three:
  - HSE clock divided by 128
  - LSE oscillator clock
  - LSI oscillator clock (refer to [Section 6.2.8: RTC clock](#) for details)
- Two separate reset types:
  - The APB1 interface is reset by system reset
  - The RTC Core (Prescaler, Alarm, Counter and Divider) is reset only by a Backup domain reset (see [Section 6.1.3: Backup domain reset on page 82](#)).
- Three dedicated maskable interrupt lines:
  - Alarm interrupt, for generating a software programmable alarm interrupt.
  - Seconds interrupt, for generating a periodic interrupt signal with a programmable period length (up to 1 second).
  - Overflow interrupt, to detect when the internal programmable counter rolls over to zero.

## 17.3 RTC functional description

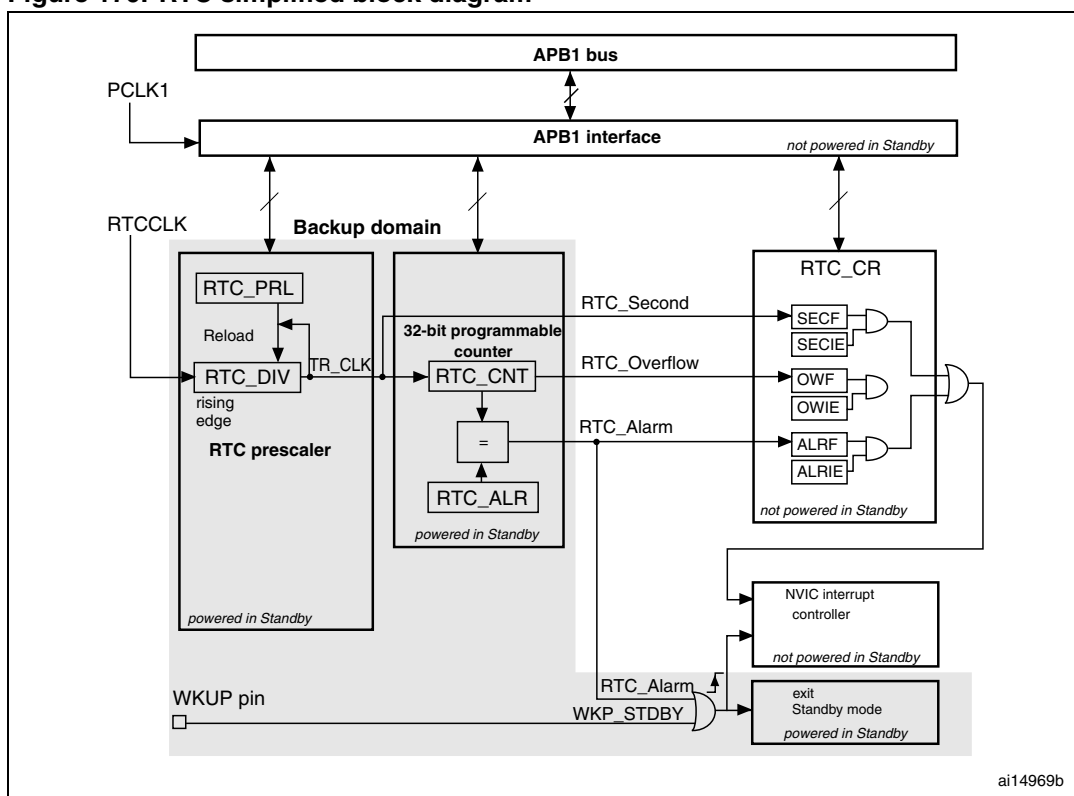
### 17.3.1 Overview

The RTC consists of two main units (see [Figure 179 on page 449](#)). The first one (APB1 Interface) is used to interface with the APB1 bus. This unit also contains a set of 16-bit registers accessible from the APB1 bus in read or write mode (for more information refer to [Section 17.4: RTC registers on page 451](#)). The APB1 interface is clocked by the APB1 bus clock in order to interface with the APB1 bus.

The other unit (RTC Core) consists of a chain of programmable counters made of two main blocks. The first block is the RTC prescaler block, which generates the RTC time base TR\_CLK that can be programmed to have a period of up to 1 second. It includes a 20-bit programmable divider (RTC Prescaler). Every TR\_CLK period, the RTC generates an interrupt (Second Interrupt) if it is enabled in the RTC\_CR register. The second block is a 32-bit programmable counter that can be initialized to the current system time. The system time is incremented at the TR\_CLK rate and compared with a programmable date (stored in the RTC\_ALR register) in order to generate an alarm interrupt, if enabled in the RTC\_CR control register.



Figure 179. RTC simplified block diagram



### 17.3.2 Resetting RTC registers

All system registers are asynchronously reset by a System Reset or Power Reset, except for RTC\_PRL, RTC\_ALR, RTC\_CNT, and RTC\_DIV.

The RTC\_PRL, RTC\_ALR, RTC\_CNT, and RTC\_DIV registers are reset only by a Backup Domain reset. Refer to [Section 6.1.3 on page 82](#).

### 17.3.3 Reading RTC registers

The RTC core is completely independent from the RTC APB1 interface.

Software accesses the RTC prescaler, counter and alarm values through the APB1 interface but the associated readable registers are internally updated at each rising edge of the RTC clock resynchronized by the RTC APB1 clock. This is also true for the RTC flags.

This means that the first read to the RTC APB1 registers may be corrupted (generally read as 0) if the APB1 interface has previously been disabled and the read occurs immediately after the APB1 interface is enabled but before the first internal update of the registers. This can occur if:

- A system reset or power reset has occurred
- The MCU has just woken up from Standby mode (see [Section 4.3: Low-power modes](#))
- The MCU has just woken up from Stop mode (see [Section 4.3: Low-power modes](#))

In all the above cases, the RTC core has been kept running while the APB1 interface was disabled (reset, not clocked or unpowered).

Consequently when reading the RTC registers, after having disabled the RTC APB1 interface, the software must first wait for the RSF bit (Register Synchronized Flag) in the RTC\_CRL register to be set by hardware.

Note that the RTC APB1 interface is not affected by WFI and WFE low-power modes.

### 17.3.4 Configuring RTC registers

To write in the RTC\_PRL, RTC\_CNT, RTC\_ALR registers, the peripheral must enter Configuration Mode. This is done by setting the CNF bit in the RTC\_CRL register.

In addition, writing to any RTC register is only enabled if the previous write operation is finished. To enable the software to detect this situation, the RTOFF status bit is provided in the RTC\_CR register to indicate that an update of the registers is in progress. A new value can be written to the RTC registers only when the RTOFF status bit value is '1'.

#### Configuration procedure:

1. Poll RTOFF, wait until its value goes to '1'
2. Set the CNF bit to enter configuration mode
3. Write to one or more RTC registers
4. Clear the CNF bit to exit configuration mode
5. Poll RTOFF, wait until its value goes to '1' to check the end of the write operation.

The write operation only executes when the CNF bit is cleared; it takes at least three RTCCLK cycles to complete.

### 17.3.5 RTC flag assertion

The RTC Second flag (SECF) is asserted on each RTC Core clock cycle before the update of the RTC Counter.

The RTC Overflow flag (OWF) is asserted on the last RTC Core clock cycle before the counter reaches 0x0000.

The RTC\_Alarm and RTC Alarm flag (ALRF) (see [Figure 180](#)) are asserted on the last RTC Core clock cycle before the counter reaches the RTC Alarm value stored in the Alarm register increased by one (RTC\_ALR + 1). The write operation in the RTC Alarm and RTC Second flag must be synchronized by using one of the following sequences:

- Use the RTC Alarm interrupt and inside the RTC interrupt routine, the RTC Alarm and/or RTC Counter registers are updated.
- Wait for SECF bit to be set in the RTC Control register. Update the RTC Alarm and/or the RTC Counter register.

Figure 180. RTC second and alarm waveform example with PR=0003, ALARM=0004

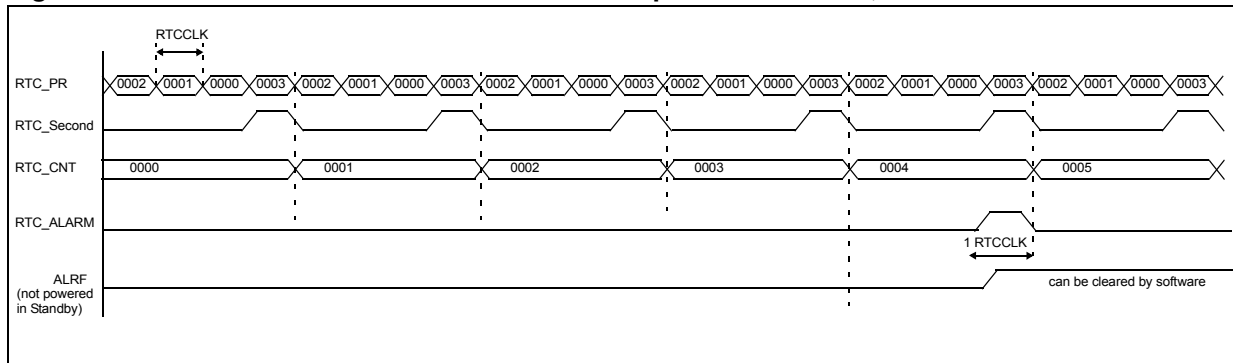
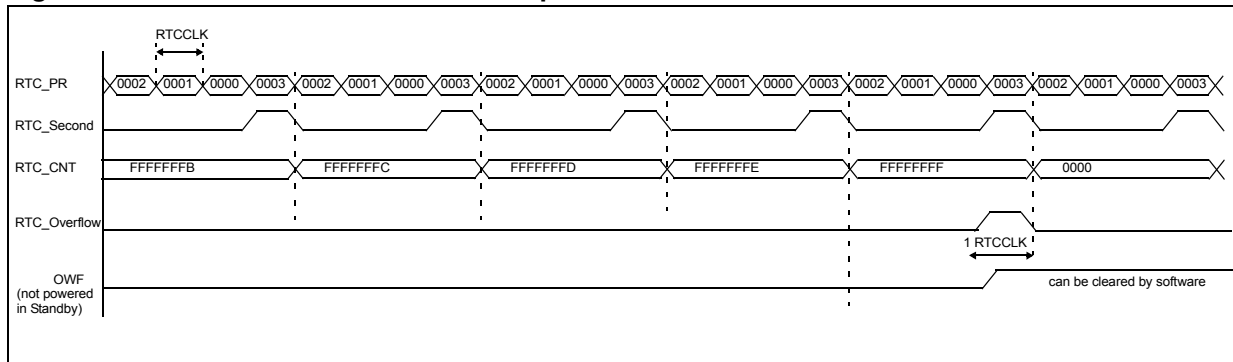


Figure 181. RTC Overflow waveform example with PR=0003



## 17.4 RTC registers

Refer to [Section 1.1 on page 40](#) for a list of abbreviations used in register descriptions.

The peripheral registers can be accessed by half-words (16-bit) or words (32-bit).

### 17.4.1 RTC control register high (RTC\_CRH)

Address offset: 0x00  
 Reset value: 0x0000

15	14	13	12	11	10	9	8	7	6	5	4	3	2	1	0
Reserved													OWIE	ALRIE	SECIE
													rw	rw	rw

Bits 15:3 Reserved, forced by hardware to 0.

Bit 2 **OWIE**: Overflow interrupt enable  
 0: Overflow interrupt is masked.  
 1: Overflow interrupt is enabled.

Bit 1 **ALRIE**: Alarm interrupt enable  
 0: Alarm interrupt is masked.  
 1: Alarm interrupt is enabled.

Bit 0 **SECIE**: Second interrupt enable  
 0: Second interrupt is masked.  
 1: Second interrupt is enabled.

These bits are used to mask interrupt requests. Note that at reset all interrupts are disabled, so it is possible to write to the RTC registers to ensure that no interrupt requests are pending after initialization. It is not possible to write to the RTC\_CRH register when the peripheral is completing a previous write operation (flagged by RTOFF=0, see [Section 17.3.4 on page 450](#)).

The RTC functions are controlled by this control register. Some bits must be written using a specific configuration procedure (see [Configuration procedure](#)).

### 17.4.2 RTC control register low (RTC\_CRL)

Address offset: 0x04  
 Reset value: 0x0020

15	14	13	12	11	10	9	8	7	6	5	4	3	2	1	0
Reserved										RTOFF	CNF	RSF	OWF	ALRF	SECF
										r	rw	rc_w0	rc_w0	rc_w0	rc_w0

Bits 15:6 Reserved, forced by hardware to 0.

Bit 5 **RTOFF**: RTC operation OFF  
 With this bit the RTC reports the status of the last write operation performed on its registers, indicating if it has been completed or not. If its value is '0' then it is not possible to write to any of the RTC registers. This bit is read only.  
 0: Last write operation on RTC registers is still ongoing.  
 1: Last write operation on RTC registers terminated.

Bit 4 **CNF**: Configuration flag

This bit must be set by software to enter in configuration mode so as to allow new values to be written in the RTC\_CNT, RTC\_ALR or RTC\_PRL registers. The write operation is only executed when the CNF bit is reset by software after has been set.

- 0: Exit configuration mode (start update of RTC registers).
- 1: Enter configuration mode.

Bit 3 **RSF**: Registers synchronized flag

This bit is set by hardware at each time the RTC\_CNT and RTC\_DIV registers are updated and cleared by software. Before any read operation after an APB1 reset or an APB1 clock stop, this bit must be cleared by software, and the user application must wait until it is set to be sure that the RTC\_CNT, RTC\_ALR or RTC\_PRL registers are synchronized.

- 0: Registers not yet synchronized.
- 1: Registers synchronized.

Bit 2 **OWF**: Overflow flag

This bit is set by hardware when the 32-bit programmable counter overflows. An interrupt is generated if OWIE=1 in the RTC\_CRH register. It can be cleared only by software. Writing '1' has no effect.

- 0: Overflow not detected
- 1: 32-bit programmable counter overflow occurred.

Bit 1 **ALRF**: Alarm flag

This bit is set by hardware when the 32-bit programmable counter reaches the threshold set in the RTC\_ALR register. An interrupt is generated if ALRIE=1 in the RTC\_CRH register. It can be cleared only by software. Writing '1' has no effect.

- 0: Alarm not detected
- 1: Alarm detected

Bit 0 **SECF**: Second flag

This bit is set by hardware when the 32-bit programmable prescaler overflows, thus incrementing the RTC counter. Hence this flag provides a periodic signal with a period corresponding to the resolution programmed for the RTC counter (usually one second). An interrupt is generated if SECIE=1 in the RTC\_CRH register. It can be cleared only by software. Writing '1' has no effect.

- 0: Second flag condition not met.
- 1: Second flag condition met.

The functions of the RTC are controlled by this control register. It is not possible to write to the RTC\_CR register while the peripheral is completing a previous write operation (flagged by RTOFF=0, see [Section 17.3.4 on page 450](#)).

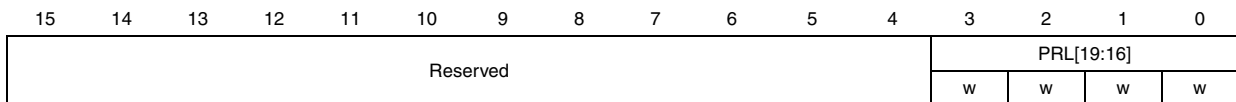
- Note:*
- 1 Any flag remains pending until the appropriate RTC\_CR request bit is reset by software, indicating that the interrupt request has been granted.
  - 2 At reset the interrupts are disabled, no interrupt requests are pending and it is possible to write to the RTC registers.
  - 3 The OWF, ALRF, SECF and RSF bits are not updated when the APB1 clock is not running.
  - 4 The OWF, ALRF, SECF and RSF bits can only be set by hardware and only cleared by software.
  - 5 If ALRF = 1 and ALRIE = 1, the RTC global interrupt is enabled. If EXTI Line 17 is also enabled through the EXTI Controller, both the RTC global interrupt and the RTC Alarm interrupt are enabled.
  - 6 If ALRF = 1, the RTC Alarm interrupt is enabled if EXTI Line 17 is enabled through the EXTI Controller in interrupt mode. When the EXTI Line 17 is enabled in event mode, a pulse is generated on this line (no RTC Alarm interrupt generation).

### 17.4.3 RTC prescaler load register (RTC\_PRLH / RTC\_PRL)

The Prescaler Load registers keep the period counting value of the RTC prescaler. They are write-protected by the RTOFF bit in the RTC\_CR register, and a write operation is allowed if the RTOFF value is '1'.

#### RTC prescaler load register high (RTC\_PRLH)

Address offset: 0x08  
 Write only (see [Section 17.3.4 on page 450](#))  
 Reset value: 0x0000



Bits 15:4 Reserved, forced by hardware to 0.

Bits 3:0 **PRL[19:16]**: RTC prescaler reload value high

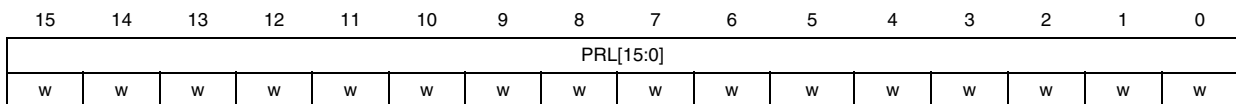
These bits are used to define the counter clock frequency according to the following formula:

$$f_{TR\_CLK} = f_{RTCCLK} / (PRL[19:0] + 1)$$

**Caution:** The zero value is not recommended. RTC interrupts and flags cannot be asserted correctly.

#### RTC prescaler load register low (RTC\_PRL)

Address offset: 0x0C  
 Write only (see [Section 17.3.4 on page 450](#))  
 Reset value: 0x8000



Bits 15:0 **PRL[15:0]**: RTC prescaler reload value low

These bits are used to define the counter clock frequency according to the following formula:

$$f_{TR\_CLK} = f_{RTCCLK} / (PRL[19:0] + 1)$$

*Note:* If the input clock frequency ( $f_{RTCCLK}$ ) is 32.768 kHz, write 7FFFh in this register to get a signal period of 1 second.

### 17.4.4 RTC prescaler divider register (RTC\_DIVH / RTC\_DIVL)

During each period of TR\_CLK, the counter inside the RTC prescaler is reloaded with the value stored in the RTC\_PRL register. To get an accurate time measurement it is possible to read the current value of the prescaler counter, stored in the RTC\_DIV register, without stopping it. This register is read-only and it is reloaded by hardware after any change in the RTC\_PRL or RTC\_CNT registers.

**RTC prescaler divider register high (RTC\_DIVH)**

Address offset: 0x10  
 Reset value: 0x0000

15	14	13	12	11	10	9	8	7	6	5	4	3	2	1	0
Reserved												RTC_DIV[19:16]			
												r	r	r	r

Bits 15:4 Reserved

Bits 3:0 **RTC\_DIV[19:16]**: RTC clock divider high

**RTC prescaler divider register low (RTC\_DIVL)**

Address offset: 0x14  
 Reset value: 0x8000

15	14	13	12	11	10	9	8	7	6	5	4	3	2	1	0
RTC_DIV[15:0]															
r	r	r	r	r	r	r	r	r	r	r	r	r	r	r	r

Bits 15:0 **RTC\_DIV[15:0]**: RTC clock divider low

**17.4.5 RTC counter register (RTC\_CNTH / RTC\_CNTL)**

The RTC core has one 32-bit programmable counter, accessed through two 16-bit registers; the count rate is based on the TR\_CLK time reference, generated by the prescaler. RTC\_CNT registers keep the counting value of this counter. They are write-protected by bit RTOFF in the RTC\_CR register, and a write operation is allowed if the RTOFF value is '1'. A write operation on the upper (RTC\_CNTH) or lower (RTC\_CNTL) registers directly loads the corresponding programmable counter and reloads the RTC Prescaler. When reading, the current value in the counter (system date) is returned.

**RTC counter register high (RTC\_CNTH)**

Address offset: 0x18  
 Reset value: 0x0000

15	14	13	12	11	10	9	8	7	6	5	4	3	2	1	0
RTC_CNT[31:16]															
rw	rw	rw	rw	rw	rw	rw	rw	rw	rw	rw	rw	rw	rw	rw	rw

Bits 15:0 **RTC\_CNT[31:16]**: RTC counter high

Reading the RTC\_CNTH register, the current value of the high part of the RTC Counter register is returned. To write to this register it is necessary to enter configuration mode (see [Section 17.3.4: Configuring RTC registers on page 450](#)).

**RTC counter register low (RTC\_CNTL)**

Address offset: 0x1C  
 Reset value: 0x0000

15	14	13	12	11	10	9	8	7	6	5	4	3	2	1	0
RTC_CNTL[15:0]															
rw	rw	rw	rw	rw	rw	rw	rw	rw	rw	rw	rw	rw	rw	rw	rw

Bits 15:0 **RTC\_CNTL[15:0]**: RTC counter low  
 Reading the RTC\_CNTL register, the current value of the lower part of the RTC Counter register is returned. To write to this register it is necessary to enter configuration mode (see [Section 17.3.4: Configuring RTC registers on page 450](#)).

**17.4.6 RTC alarm register high (RTC\_ALRH / RTC\_ALRL)**

When the programmable counter reaches the 32-bit value stored in the RTC\_ALR register, an alarm is triggered and the RTC\_alarmIT interrupt request is generated. This register is write-protected by the RTOFF bit in the RTC\_CR register, and a write operation is allowed if the RTOFF value is '1'.

**RTC alarm register high (RTC\_ALRH)**

Address offset: 0x20  
 Write only (see [Section 17.3.4 on page 450](#))  
 Reset value: 0xFFFF

15	14	13	12	11	10	9	8	7	6	5	4	3	2	1	0
RTC_ALR[31:16]															
w	w	w	w	w	w	w	w	w	w	w	w	w	w	w	w

Bits 15:0 **RTC\_ALR[31:16]**: RTC alarm high  
 The high part of the alarm time is written by software in this register. To write to this register it is necessary to enter configuration mode (see [Section 17.3.4: Configuring RTC registers on page 450](#)).

**RTC alarm register low (RTC\_ALRL)**

Address offset: 0x24  
 Write only (see [Section 17.3.4 on page 450](#))  
 Reset value: 0xFFFF

15	14	13	12	11	10	9	8	7	6	5	4	3	2	1	0
RTC_ALR[15:0]															
w	w	w	w	w	w	w	w	w	w	w	w	w	w	w	w

Bits 15:0 **RTC\_ALR[15:0]**: RTC alarm low  
 The low part of the alarm time is written by software in this register. To write to this register it is necessary to enter configuration mode (see [Section 17.3.4: Configuring RTC registers on page 450](#)).



### 17.4.7 RTC register map

RTC registers are mapped as 16-bit addressable registers as described in the table below:

**Table 93. RTC register map and reset values**

Offset	Register	31	30	29	28	27	26	25	24	23	22	21	20	19	18	17	16	15	14	13	12	11	10	9	8	7	6	5	4	3	2	1	0																									
0x000	RTC_CRH Reset value	Reserved																																																								
0x004	RTC_CRL Reset value	Reserved																																																								
0x008	RTC_PRLH Reset value	Reserved																																																								
0x00C	RTC_PRL Reset value	Reserved															PRL[15:0]																																									
0x010	RTC_DIVH Reset value	Reserved															DIV[31:16]																																									
0x014	RTC_DIVL Reset value	Reserved															DIV[15:0]																																									
0x018	RTC_CNTH Reset value	Reserved															CNT[13:16]																																									
0x01C	RTC_CNTL Reset value	Reserved															CNT[15:0]																																									
0x020	RTC_ALRH Reset value	Reserved															ALR[31:16]																																									
0x024	RTC_ALRL Reset value	Reserved															ALR[15:0]																																									

Refer to [Table 1 on page 44](#) for the register boundary addresses.

## 18 Independent watchdog (IWDG)

**Low-density devices** are STM32F101xx, STM32F102xx and STM32F103xx microcontrollers where the Flash memory density ranges between 16 and 32 Kbytes.

**Medium-density devices** are STM32F101xx, STM32F102xx and STM32F103xx microcontrollers where the Flash memory density ranges between 64 and 128 Kbytes.

**High-density devices** are STM32F101xx and STM32F103xx microcontrollers where the Flash memory density ranges between 256 and 512 Kbytes.

**XL-density devices** are STM32F101xx and STM32F103xx microcontrollers where the Flash memory density ranges between 768 Kbytes and 1 Mbyte.

**Connectivity line devices** are STM32F105xx and STM32F107xx microcontrollers.

This section applies to the whole STM32F10xxx family, unless otherwise specified.

### 18.1 IWDG introduction

The STM32F10xxx have two embedded watchdog peripherals which offer a combination of high safety level, timing accuracy and flexibility of use. Both watchdog peripherals (Independent and Window) serve to detect and resolve malfunctions due to software failure, and to trigger system reset or an interrupt (window watchdog only) when the counter reaches a given timeout value.

The independent watchdog (IWDG) is clocked by its own dedicated low-speed clock (LSI) and thus stays active even if the main clock fails. The window watchdog (WWDG) clock is prescaled from the APB1 clock and has a configurable time-window that can be programmed to detect abnormally late or early application behavior.

The IWDG is best suited to applications which require the watchdog to run as a totally independent process outside the main application, but have lower timing accuracy constraints. The WWDG is best suited to applications which require the watchdog to react within an accurate timing window. For further information on the window watchdog, refer to [Section 19 on page 464](#).

### 18.2 IWDG main features

- Free-running downcounter
- clocked from an independent RC oscillator (can operate in Standby and Stop modes)
- Reset (if watchdog activated) when the downcounter value of 0x000 is reached

### 18.3 IWDG functional description

[Figure 182](#) shows the functional blocks of the independent watchdog module.

When the independent watchdog is started by writing the value 0xCCCC in the Key register (IWDG\_KR), the counter starts counting down from the reset value of 0xFFFF. When it reaches the end of count value (0x000) a reset signal is generated (IWDG reset).

Whenever the key value 0xAAAA is written in the IWDG\_KR register, the IWDG\_RLR value is reloaded in the counter and the watchdog reset is prevented.

### 18.3.1 Hardware watchdog

If the “Hardware watchdog” feature is enabled through the device option bits, the watchdog is automatically enabled at power-on, and will generate a reset unless the Key register is written by the software before the counter reaches end of count.

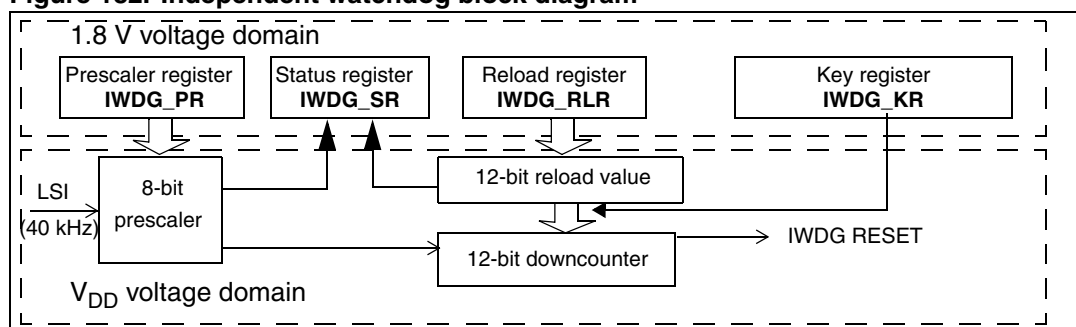
### 18.3.2 Register access protection

Write access to the IWDG\_PR and IWDG\_RLR registers is protected. To modify them, you must first write the code 0x5555 in the IWDG\_KR register. A write access to this register with a different value will break the sequence and register access will be protected again. This implies that it is the case of the reload operation (writing 0xAAAA). A status register is available to indicate that an update of the prescaler or the down-counter reload value is on going.

### 18.3.3 Debug mode

When the microcontroller enters debug mode (Cortex-M3 core halted), the IWDG counter either continues to work normally or stops, depending on DBG\_IWDG\_STOP configuration bit in DBG module. For more details, refer to [Section 30.16.2: Debug support for timers, watchdog, bxCAN and I2C](#).

**Figure 182. Independent watchdog block diagram**



*Note:* The watchdog function is implemented in the V<sub>DD</sub> voltage domain that is still functional in Stop and Standby modes.

**Table 94. Min/max IWDG timeout period at 40 kHz (LSI) <sup>(1)</sup>**

Prescaler divider	PR[2:0] bits	Min timeout (ms) RL[11:0]= 0x000	Max timeout (ms) RL[11:0]= 0xFFF
/4	0	0.1	409.6
/8	1	0.2	819.2
/16	2	0.4	1638.4
/32	3	0.8	3276.8
/64	4	1.6	6553.6

**Table 94. Min/max IWDG timeout period at 40 kHz (LSI) (continued)<sup>(1)</sup>**

Prescaler divider	PR[2:0] bits	Min timeout (ms) RL[11:0]= 0x000	Max timeout (ms) RL[11:0]= 0xFFF
/128	5	3.2	13107.2
/256	6 (or 7)	6.4	26214.4

1. These timings are given for a 40 kHz clock but the microcontroller’s internal RC frequency can vary from 30 to 60 kHz. Moreover, given an exact RC oscillator frequency, the exact timings still depend on the phasing of the APB interface clock versus the LSI clock so that there is always a full RC period of uncertainty.

The LSI can be calibrated so as to compute the IWDG timeout with an acceptable accuracy. For more details refer to [LSI calibration on page 87](#).

## 18.4 IWDG registers

Refer to [Section 1.1 on page 40](#) for a list of abbreviations used in register descriptions.

The peripheral registers can be accessed by half-words (16-bit) or words (32-bit).

### 18.4.1 Key register (IWDG\_KR)

Address offset: 0x00

Reset value: 0x0000 0000 (reset by Standby mode)

31	30	29	28	27	26	25	24	23	22	21	20	19	18	17	16	15	14	13	12	11	10	9	8	7	6	5	4	3	2	1	0
Reserved																KEY[15:0]															
15	14	13	12	11	10	9	8	7	6	5	4	3	2	1	0	w	w	w	w	w	w	w	w	w	w	w	w	w	w	w	w

Bits 31:16 Reserved, read as 0.

Bits 15:0 **KEY[15:0]**: Key value (write only, read 0000h)

These bits must be written by software at regular intervals with the key value AAAAh, otherwise the watchdog generates a reset when the counter reaches 0.

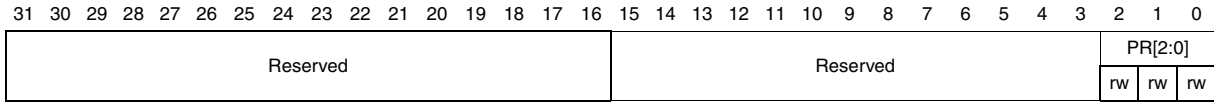
Writing the key value 5555h to enables access to the IWDG\_PR and IWDG\_RLR registers (see [Section 18.3.2](#))

Writing the key value CCCCh starts the watchdog (except if the hardware watchdog option is selected)

### 18.4.2 Prescaler register (IWDG\_PR)

Address offset: 0x04

Reset value: 0x0000 0000



Bits 31:3 Reserved, read as 0.

Bits 2:0 **PR[2:0]**: Prescaler divider

These bits are write access protected see [Section 18.3.2](#). They are written by software to select the prescaler divider feeding the counter clock. PVU bit of IWDG\_SR must be reset in order to be able to change the prescaler divider.

- 000: divider /4
- 001: divider /8
- 010: divider /16
- 011: divider /32
- 100: divider /64
- 101: divider /128
- 110: divider /256
- 111: divider /256

*Note: Reading this register returns the prescaler value from the VDD voltage domain. This value may not be up to date/valid if a write operation to this register is ongoing. For this reason the value read from this register is valid only when the PVU bit in the IWDG\_SR register is reset.*

### 18.4.3 Reload register (IWDG\_RLR)

Address offset: 0x08

Reset value: 0x0000 0FFF (reset by Standby mode)

31	30	29	28	27	26	25	24	23	22	21	20	19	18	17	16	15	14	13	12	11	10	9	8	7	6	5	4	3	2	1	0		
Reserved																Reserved		RL[11:0]															
15	14	13	12	11	10	9	8	7	6	5	4	3	2	1	0			rw	rw	rw	rw	rw	rw	rw	rw	rw	rw	rw	rw	rw	rw	rw	rw

Bits 31:12 Reserved, read as 0.

Bits11:0 **RL[11:0]**: Watchdog counter reload value

These bits are write access protected see [Section 18.3.2](#). They are written by software to define the value to be loaded in the watchdog counter each time the value AAAAh is written in the IWDG\_KR register. The watchdog counter counts down from this value. The timeout period is a function of this value and the clock prescaler. Refer to [Table 94](#).

The RVU bit in the IWDG\_SR register must be reset in order to be able to change the reload value.

*Note: Reading this register returns the reload value from the VDD voltage domain. This value may not be up to date/valid if a write operation to this register is ongoing on this register. For this reason the value read from this register is valid only when the RVU bit in the IWDG\_SR register is reset.*

### 18.4.4 Status register (IWDG\_SR)

Address offset: 0x0C

Reset value: 0x0000 0000 (not reset by Standby mode)

31	30	29	28	27	26	25	24	23	22	21	20	19	18	17	16	15	14	13	12	11	10	9	8	7	6	5	4	3	2	1	0
Reserved																Reserved										RVU	PVU				
																										r	r				

Bits 31:2 Reserved

Bit 1 **RVU**: Watchdog counter reload value update

This bit is set by hardware to indicate that an update of the reload value is ongoing. It is reset by hardware when the reload value update operation is completed in the V<sub>DD</sub> voltage domain (takes up to 5 RC 40 kHz cycles).

Reload value can be updated only when RVU bit is reset.

Bit 0 **PVU**: Watchdog prescaler value update

This bit is set by hardware to indicate that an update of the prescaler value is ongoing. It is reset by hardware when the prescaler update operation is completed in the V<sub>DD</sub> voltage domain (takes up to 5 RC 40 kHz cycles).

Prescaler value can be updated only when PVU bit is reset.

*Note: If several reload values or prescaler values are used by application, it is mandatory to wait until RVU bit is reset before changing the reload value and to wait until PVU bit is reset before changing the prescaler value. However, after updating the prescaler and/or the reload value it is not necessary to wait until RVU or PVU is reset before continuing code execution (even in case of low-power mode entry, the write operation is taken into account and will complete)*

### 18.4.5 IWDG register map

The following table gives the IWDG register map and reset values.

**Table 95. IWDG register map and reset values**

Offset	Register	31	30	29	28	27	26	25	24	23	22	21	20	19	18	17	16	15	14	13	12	11	10	9	8	7	6	5	4	3	2	1	0									
0x00	IWDG_KR	Reserved															KEY[15:0]																									
	Reset value																0	0	0	0	0	0	0	0	0	0	0	0	0	0	0	0	0	0	0	0	0	0	0	0	0	0
0x04	IWDG_PR	Reserved																								PR[2:0]																
	Reset value																									0	0	0														
0x08	IWDG_RLR	Reserved															RL[11:0]																									
	Reset value																1	1	1	1	1	1	1	1	1	1	1	1	1	1	1	1	1	1	1	1	1	1	1	1	1	1
0x0C	IWDG_SR	Reserved																								RVU	PVU															
	Reset value																									0	0															

Refer to *Register boundary addresses* table.

## 19 Window watchdog (WWDG)

**Low-density devices** are STM32F101xx, STM32F102xx and STM32F103xx microcontrollers where the Flash memory density ranges between 16 and 32 Kbytes.

**Medium-density devices** are STM32F101xx, STM32F102xx and STM32F103xx microcontrollers where the Flash memory density ranges between 64 and 128 Kbytes.

**High-density devices** are STM32F101xx and STM32F103xx microcontrollers where the Flash memory density ranges between 256 and 512 Kbytes.

**XL-density devices** are STM32F101xx and STM32F103xx microcontrollers where the Flash memory density ranges between 768 Kbytes and 1 Mbyte.

**Connectivity line devices** are STM32F105xx and STM32F107xx microcontrollers.

This section applies to the whole STM32F10xxx family, unless otherwise specified.

### 19.1 WWDG introduction

The window watchdog is used to detect the occurrence of a software fault, usually generated by external interference or by unforeseen logical conditions, which causes the application program to abandon its normal sequence. The watchdog circuit generates an MCU reset on expiry of a programmed time period, unless the program refreshes the contents of the downcounter before the T6 bit becomes cleared. An MCU reset is also generated if the 7-bit downcounter value (in the control register) is refreshed before the downcounter has reached the window register value. This implies that the counter must be refreshed in a limited window.

### 19.2 WWDG main features

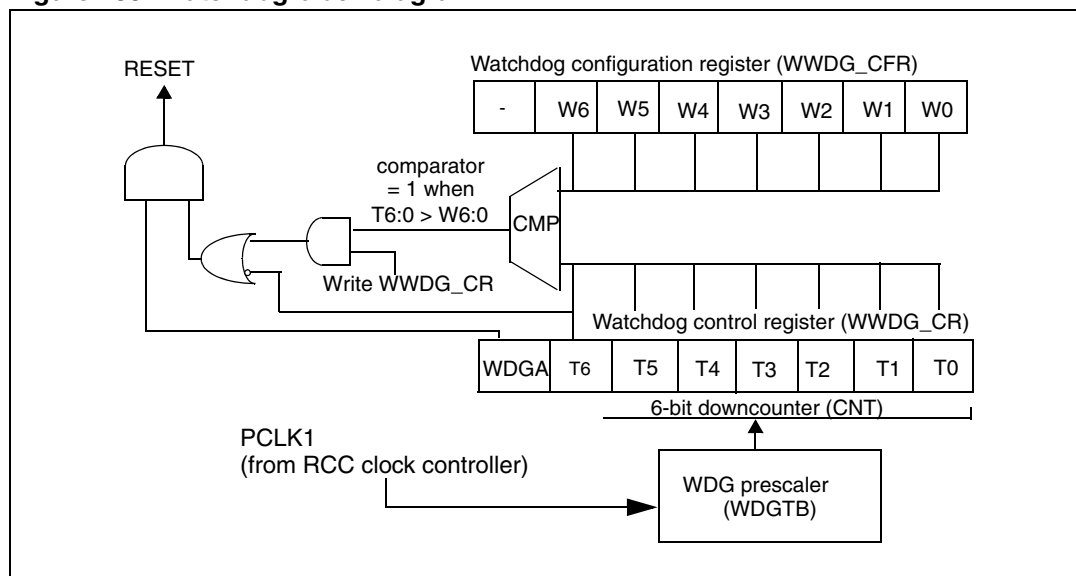
- Programmable free-running downcounter
- Conditional reset
  - Reset (if watchdog activated) when the downcounter value becomes less than 40h
  - Reset (if watchdog activated) if the downcounter is reloaded outside the window (see [Figure 184](#))
- Early wakeup interrupt (EWI): triggered (if enabled and the watchdog activated) when the downcounter is equal to 40h. Can be used to reload the counter and prevent WWDG reset

### 19.3 WWDG functional description

If the watchdog is activated (the WDGA bit is set in the WWDG\_CR register) and when the 7-bit downcounter (T[6:0] bits) rolls over from 0x40 to 0x3F (T6 becomes cleared), it initiates a reset. If the software reloads the counter while the counter is greater than the value stored in the window register, then a reset is generated.



Figure 183. Watchdog block diagram



The application program must write in the WWDG\_CR register at regular intervals during normal operation to prevent an MCU reset. This operation must occur only when the counter value is lower than the window register value. The value to be stored in the WWDG\_CR register must be between 0xFF and 0xC0:

- **Enabling the watchdog:**  
The watchdog is always disabled after a reset. It is enabled by setting the WDGA bit in the WWDG\_CR register, then it cannot be disabled again except by a reset.
- **Controlling the downcounter:**  
This downcounter is free-running: It counts down even if the watchdog is disabled. When the watchdog is enabled, the T6 bit must be set to prevent generating an immediate reset.  
The T[5:0] bits contain the number of increments which represents the time delay before the watchdog produces a reset. The timing varies between a minimum and a maximum value due to the unknown status of the prescaler when writing to the WWDG\_CR register (see [Figure 184](#)).  
The Configuration register (WWDG\_CFR) contains the high limit of the window: To prevent a reset, the downcounter must be reloaded when its value is lower than the window register value and greater than 0x3F. [Figure 184](#) describes the window watchdog process.  
Another way to reload the counter is to use the early wakeup interrupt (EWI). This interrupt is enabled by setting the EWI bit in the WWDG\_CFR register. When the downcounter reaches the value 40h, this interrupt is generated and the corresponding interrupt service routine (ISR) can be used to reload the counter to prevent WWDG reset.  
This interrupt is cleared by writing '0' to the EWIF bit in the WWDG\_SR register.

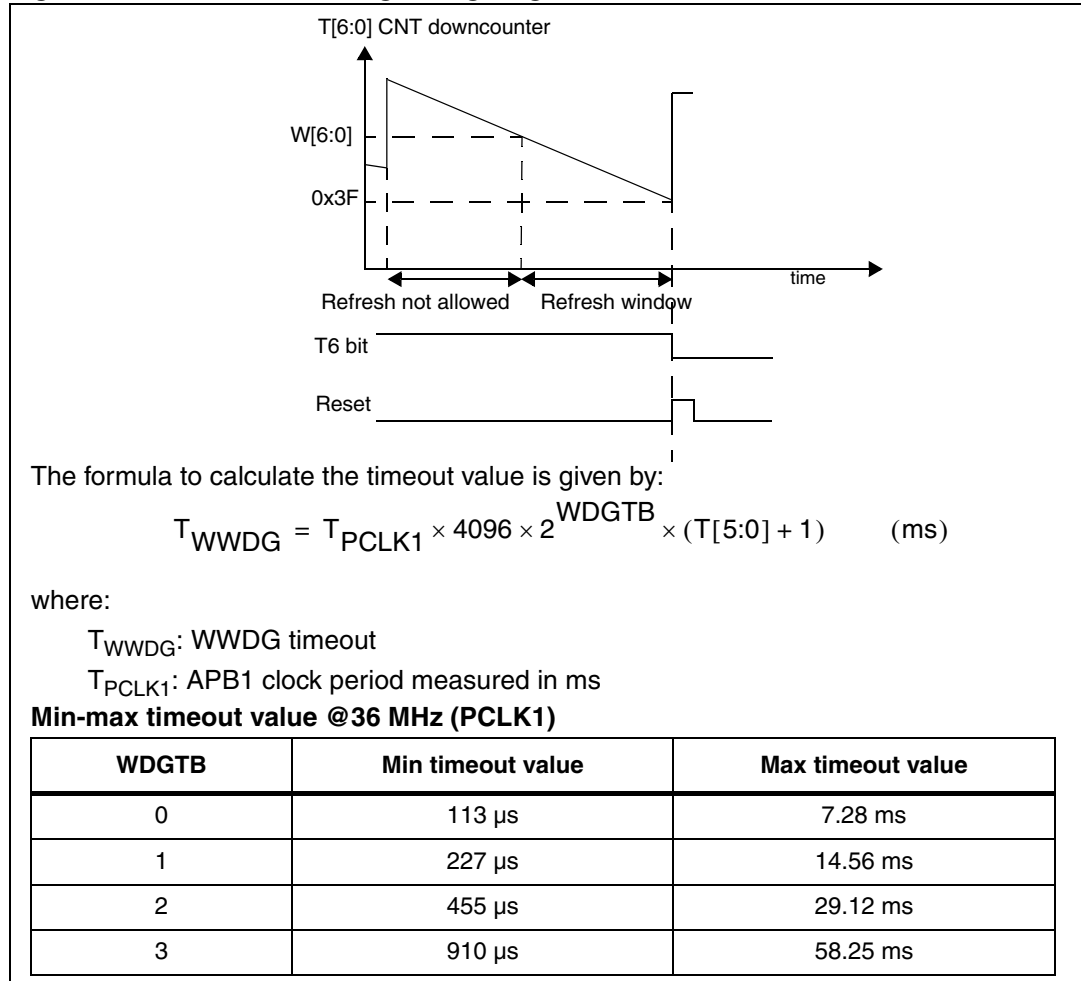
**Note:** *The T6 bit can be used to generate a software reset (the WDGA bit is set and the T6 bit is cleared).*

## 19.4 How to program the watchdog timeout

You can use the formula in [Figure 184](#) to calculate the WWDG timeout.

**Warning:** When writing to the WWDG\_CR register, always write 1 in the T6 bit to avoid generating an immediate reset.

**Figure 184. Window watchdog timing diagram**



## 19.5 Debug mode

When the microcontroller enters debug mode (Cortex-M3 core halted), the WWDG counter either continues to work normally or stops, depending on DBG\_WWDG\_STOP configuration bit in DBG module. For more details, refer to [Section 30.16.2: Debug support for timers, watchdog, bxCAN and I2C](#).

## 19.6 WWDG registers

Refer to [Section 1.1 on page 40](#) for a list of abbreviations used in register descriptions.

The peripheral registers can be accessed by half-words (16-bit) or words (32-bit).

### 19.6.1 Control register (WWDG\_CR)

Address offset: 0x00

Reset value: 0x7F

31	30	29	28	27	26	25	24	23	22	21	20	19	18	17	16
Reserved															
15	14	13	12	11	10	9	8	7	6	5	4	3	2	1	0
Reserved								WDGA	T6	T5	T4	T3	T2	T1	T0
								rs	rw	rw	rw	rw	rw	rw	rw

Bits 31:8 Reserved

Bit 7 **WDGA**: Activation bit

This bit is set by software and only cleared by hardware after a reset. When WDGA = 1, the watchdog can generate a reset.

- 0: Watchdog disabled
- 1: Watchdog enabled

Bits 6:0 **T[6:0]**: 7-bit counter (MSB to LSB)

These bits contain the value of the watchdog counter. It is decremented every  $(4096 \times 2^{WDGTB})$  PCLK1 cycles. A reset is produced when it rolls over from 40h to 3Fh (T6 becomes cleared).

### 19.6.2 Configuration register (WWDG\_CFR)

Address offset: 0x04

Reset value: 0x7F

31	30	29	28	27	26	25	24	23	22	21	20	19	18	17	16	
Reserved																
15	14	13	12	11	10	9	8	7	6	5	4	3	2	1	0	
Reserved							EWI	WDG TB1	WDG TB0	W6	W5	W4	W3	W2	W1	W0
							rs	rw	rw	rw	rw	rw	rw	rw	rw	rw

Bit 31:10 Reserved

Bit 9 **EWI**: Early wakeup interrupt

When set, an interrupt occurs whenever the counter reaches the value 40h. This interrupt is only cleared by hardware after a reset.

Bits 8:7 **WDGTB[1:0]**: Timer base

The time base of the prescaler can be modified as follows:

- 00: CK Counter Clock (PCLK1 div 4096) div 1
- 01: CK Counter Clock (PCLK1 div 4096) div 2
- 10: CK Counter Clock (PCLK1 div 4096) div 4
- 11: CK Counter Clock (PCLK1 div 4096) div 8

Bits 6:0 **W[6:0]**: 7-bit window value

These bits contain the window value to be compared to the downcounter.

### 19.6.3 Status register (WWDG\_SR)

Address offset: 0x08

Reset value: 0x00

31	30	29	28	27	26	25	24	23	22	21	20	19	18	17	16
Reserved															
15	14	13	12	11	10	9	8	7	6	5	4	3	2	1	0
Reserved														EWIF	
														rc_w0	

Bit 31:1 Reserved

Bit 0 **EWIF**: Early wakeup interrupt flag

This bit is set by hardware when the counter has reached the value 40h. It must be cleared by software by writing '0. A write of '1 has no effect. This bit is also set if the interrupt is not enabled.

### 19.6.4 WWDG register map

The following table gives the WWDG register map and reset values.

**Table 96. WWDG register map and reset values**

Offset	Register	31	30	29	28	27	26	25	24	23	22	21	20	19	18	17	16	15	14	13	12	11	10	9	8	7	6	5	4	3	2	1	0	
0x00	<b>WWDG_CR</b>	Reserved																							WDGA	T[6:0]								
	Reset value																								0	1	1	1	1	1	1	1		
0x04	<b>WWDG_CFR</b>	Reserved																							EWI	WDGTB1	WDGTB0	W[6:0]						
	Reset value																								0	0	0	1	1	1	1	1	1	1
0x08	<b>WWDG_SR</b>	Reserved																							EWIF									
	Reset value																								0									

Refer to the Register boundary addresses table.

## 20 Flexible static memory controller (FSMC)

**Low-density devices** are STM32F101xx, STM32F102xx and STM32F103xx microcontrollers where the Flash memory density ranges between 16 and 32 Kbytes.

**Medium-density devices** are STM32F101xx and STM32F103xx microcontrollers where the Flash memory density ranges between 32 and 128 Kbytes.

**High-density devices** are STM32F101xx and STM32F103xx microcontrollers where the Flash memory density ranges between 256 and 512 Kbytes.

**XL-density devices** are STM32F101xx and STM32F103xx microcontrollers where the Flash memory density ranges between 768 Kbytes and 1 Mbyte.

**Connectivity line devices** are STM32F105xx and STM32F107xx microcontrollers.

This section applies to high-density and XL-density devices only.

### 20.1 FSMC main features

The FSMC block is able to interface with synchronous and asynchronous memories and 16-bit PC memory cards. Its main purpose is to:

- Translate the AHB transactions into the appropriate external device protocol
- Meet the access timing requirements of the external devices

All external memories share the addresses, data and control signals with the controller. Each external device is accessed by means of a unique chip select. The FSMC performs only one access at a time to an external device.

The FSMC has the following main features:

- Interfaces with static memory-mapped devices including:
  - Static random access memory (SRAM)
  - Read-only memory (ROM)
  - NOR Flash memory
  - PSRAM (4 memory banks)
- Two banks of NAND Flash with ECC hardware that checks up to 8 Kbytes of data
- 16-bit PC Card compatible devices
- Supports burst mode access to synchronous devices (NOR Flash and PSRAM)
- 8- or 16-bit wide databus
- Independent chip select control for each memory bank
- Independent configuration for each memory bank
- Programmable timings to support a wide range of devices, in particular:
  - Programmable wait states (up to 15)
  - Programmable bus turnaround cycles (up to 15)
  - Programmable output enable and write enable delays (up to 15)
  - Independent read and write timings and protocol, so as to support the widest variety of memories and timings

- Write enable and byte lane select outputs for use with PSRAM and SRAM devices
- Translation of 32-bit wide AHB transactions into consecutive 16-bit or 8-bit accesses to external 16-bit or 8-bit devices
- A Write FIFO, 2 words long, each word is 32 bits wide, only stores data and not the address. Therefore, this FIFO only buffers AHB write burst transactions. This makes it possible to write to slow memories and free the AHB quickly for other operations. Only one burst at a time is buffered: if a new AHB burst or single transaction occurs while an operation is in progress, first the FIFO is drained ( The FSMC will insert wait states until the current memory access is complete).
- External asynchronous wait control

The FSMC registers that define the external device type and associated characteristics are usually set at boot time and do not change until the next reset or power-up. However, it is possible to change the settings at any time.

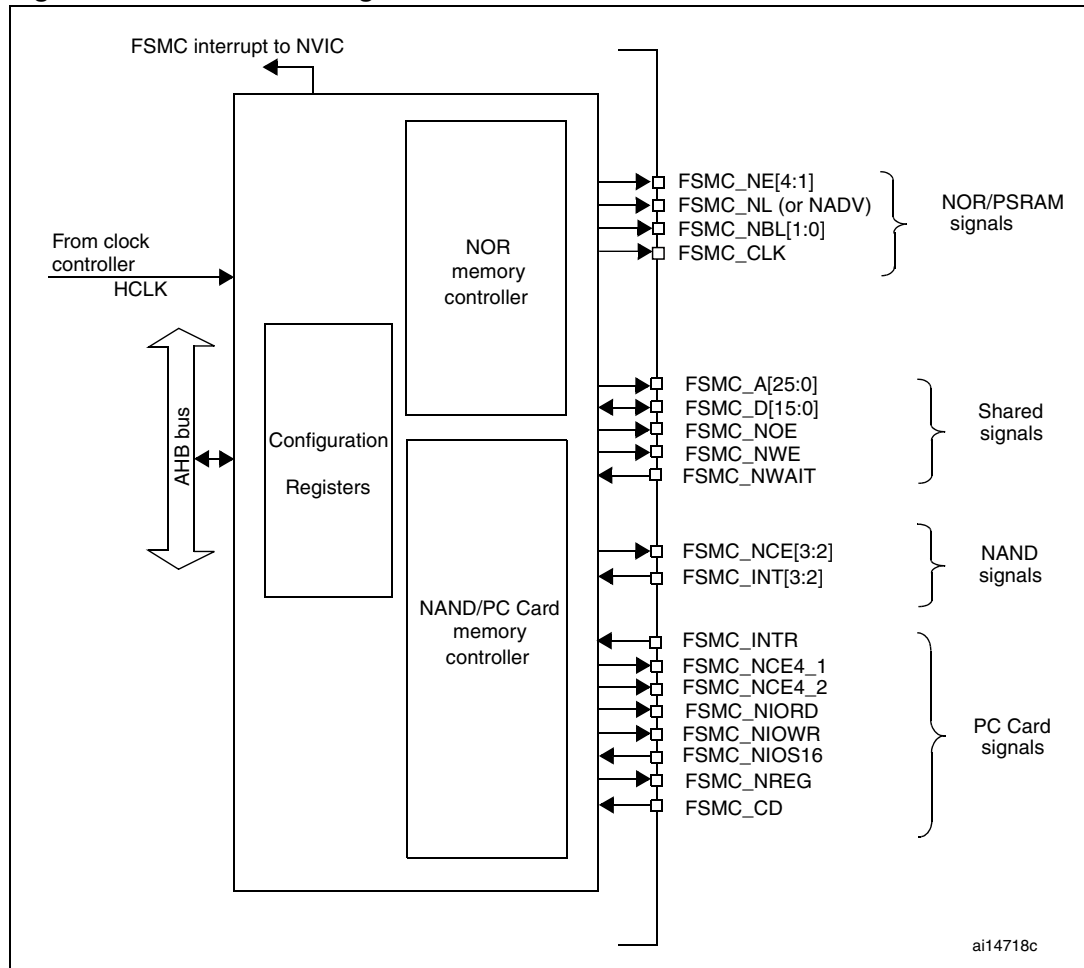
## 20.2 Block diagram

The FSMC consists of four main blocks:

- The AHB interface (including the FSMC configuration registers)
- The NOR Flash/PSRAM controller
- The NAND Flash/PC Card controller
- The external device interface

The block diagram is shown in [Figure 185](#).

Figure 185. FSMC block diagram



### 20.3 AHB interface

The AHB slave interface enables internal CPUs and other bus master peripherals to access the external static memories.

AHB transactions are translated into the external device protocol. In particular, if the selected external memory is 16 or 8 bits wide, 32-bit wide transactions on the AHB are split into consecutive 16- or 8-bit accesses.

The FSMC generates an AHB error in the following conditions:

- When reading or writing to an FSMC bank which is not enabled
- When reading or writing to the NOR Flash bank while the FACCEN bit is reset in the FSMC\_BCRx register.
- When reading or writing to the PC Card banks while the input pin FSMC\_CD (Card Presence Detection) is low.

The effect of this AHB error depends on the AHB master which has attempted the R/W access:

- If it is the Cortex™-M3 CPU, a hard fault interrupt is generated
- If it is a DMA, a DMA transfer error is generated and the corresponding DMA channel is automatically disabled.

The AHB clock (HCLK) is the reference clock for the FSMC.

## 20.3.1 Supported memories and transactions

### General transaction rules

The requested AHB transaction data size can be 8-, 16- or 32-bit wide whereas the accessed external device has a fixed data width. This may lead to inconsistent transfers.

Therefore, some simple transaction rules must be followed:

- AHB transaction size and memory data size are equal  
There is no issue in this case.
- AHB transaction size is greater than the memory size  
In this case, the FSMC splits the AHB transaction into smaller consecutive memory accesses in order to meet the external data width.
- AHB transaction size is smaller than the memory size  
Asynchronous transfers may or not be consistent depending on the type of external device.
  - Asynchronous accesses to devices that have the byte select feature (SRAM, ROM, PSRAM).  
In this case, the FSMC allows read/write transactions and accesses the right data through its byte lanes BL[1:0]
  - Asynchronous accesses to devices that do not have the byte select feature (NOR and NAND Flash 16-bit).  
This situation occurs when a byte access is requested to a 16-bit wide Flash memory. Clearly, the device cannot be accessed in byte mode (only 16-bit words can be read from/written to the Flash memory) therefore:
    - a) Write transactions are not allowed
    - b) Read transactions are allowed (the controller reads the entire 16-bit memory word and uses the needed byte only).

### Configuration registers

The FSMC can be configured using a register set. See [Section 20.5.6](#), for a detailed description of the NOR Flash/PSRAM controller registers. See [Section 20.6.8](#), for a detailed description of the NAND Flash/PC Card registers.



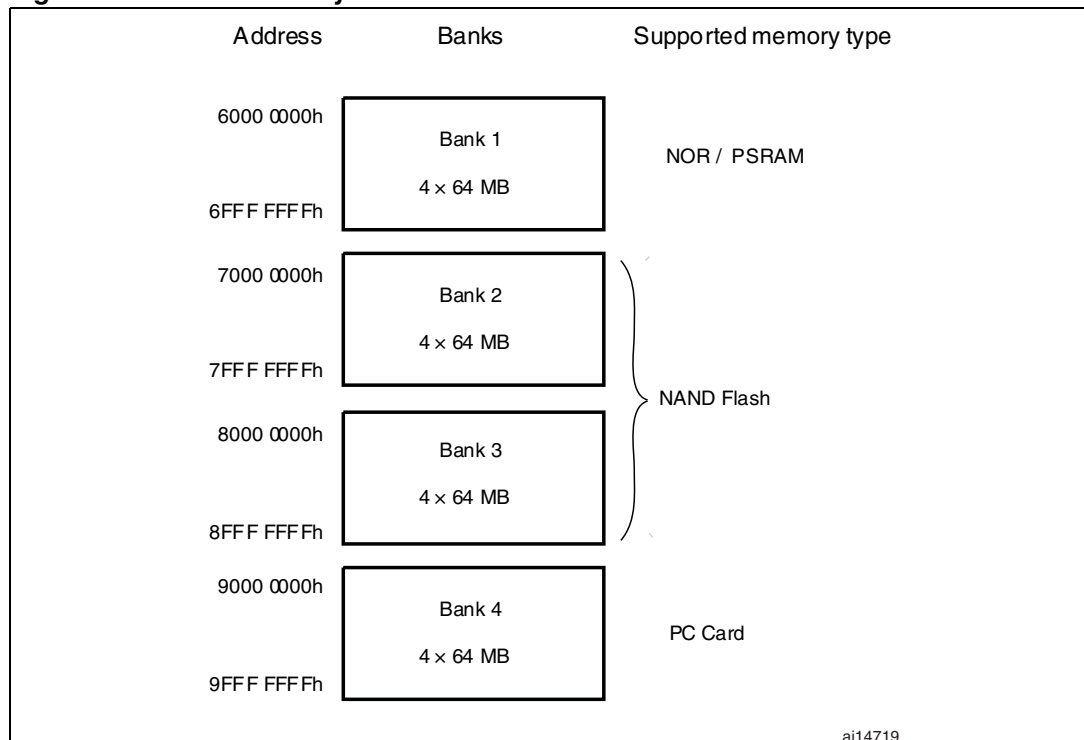
## 20.4 External device address mapping

From the FSMC point of view, the external memory is divided into 4 fixed-size banks of 256 Mbytes each (Refer to [Figure 186](#)):

- Bank 1 used to address up to 4 NOR Flash or PSRAM memory devices. This bank is split into 4 NOR/PSRAM regions with 4 dedicated Chip Select.
- Banks 2 and 3 used to address NAND Flash devices (1 device per bank)
- Bank 4 used to address a PC Card device

For each bank the type of memory to be used is user-defined in the Configuration register.

**Figure 186. FSMC memory banks**



### 20.4.1 NOR/PSRAM address mapping

HADDR[27:26] bits are used to select one of the four memory banks as shown in [Table 97](#).

**Table 97. NOR/PSRAM bank selection**

HADDR[27:26] <sup>(1)</sup>	Selected bank
00	Bank 1 NOR/PSRAM 1
01	Bank 1 NOR/PSRAM 2
10	Bank 1 NOR/PSRAM 3
11	Bank 1 NOR/PSRAM 4

1. HADDR are internal AHB address lines that are translated to external memory.

HADDR[25:0] contain the external memory address. Since HADDR is a byte address whereas the memory is addressed in words, the address actually issued to the memory varies according to the memory data width, as shown in the following table.

**Table 98. External memory address**

Memory width <sup>(1)</sup>	Data address issued to the memory	Maximum memory capacity (bits)
8-bit	HADDR[25:0]	64 Mbytes x 8 = 512 Mbit
16-bit	HADDR[25:1] >> 1	64 Mbytes/2 x 16 = 512 Mbit

1. In case of a 16-bit external memory width, the FSMC will internally use HADDR[25:1] to generate the address for external memory FSMC\_A[24:0].  
Whatever the external memory width (16-bit or 8-bit), FSMC\_A[0] should be connected to external memory address A[0].

### Wrap support for NOR Flash/PSRAM

Wrap burst mode for synchronous memories is not supported. The memories must be configured in linear burst mode of undefined length.

## 20.4.2 NAND/PC Card address mapping

In this case, three banks are available, each of them divided into memory spaces as indicated in [Table 99](#).

**Table 99. Memory mapping and timing registers**

Start address	End address	FSMC Bank	Memory space	Timing register
0x9C00 0000	0x9FFF FFFF	Bank 4 - PC card	I/O	FSMC_PIO4 (0xB0)
0x9800 0000	0x9BFF FFFF		Attribute	FSMC_PATT4 (0xAC)
0x9000 0000	0x93FF FFFF		Common	FSMC_PMEM4 (0xA8)
0x8800 0000	0x8BFF FFFF	Bank 3 - NAND Flash	Attribute	FSMC_PATT3 (0x8C)
0x8000 0000	0x83FF FFFF		Common	FSMC_PMEM3 (0x88)
0x7800 0000	0x7BFF FFFF	Bank 2- NAND Flash	Attribute	FSMC_PATT2 (0x6C)
0x7000 0000	0x73FF FFFF		Common	FSMC_PMEM2 (0x68)

For NAND Flash memory, the common and attribute memory spaces are subdivided into three sections (see in [Table 100](#) below) located in the lower 256 Kbytes:

- Data section (first 64 Kbytes in the common/attribute memory space)
- Command section (second 64 Kbytes in the common / attribute memory space)
- Address section (next 128 Kbytes in the common / attribute memory space)

**Table 100. NAND bank selections**

Section name	HADDR[17:16]	Address range
Address section	1X	0x020000-0x03FFFF
Command section	01	0x010000-0x01FFFF
Data section	00	0x000000-0x0FFFFF

The application software uses the 3 sections to access the NAND Flash memory:

- **To send a command to NAND Flash memory:** the software must write the command value to any memory location in the command section.
- **To specify the NAND Flash address that must be read or written:** the software must write the address value to any memory location in the address section. Since an address can be 4 or 5 bytes long (depending on the actual memory size), several consecutive writes to the address section are needed to specify the full address.
- **To read or write data:** the software reads or writes the data value from or to any memory location in the data section.

Since the NAND Flash memory automatically increments addresses, there is no need to increment the address of the data section to access consecutive memory locations.

## 20.5 NOR Flash/PSRAM controller

The FSMC generates the appropriate signal timings to drive the following types of memories:

- Asynchronous SRAM and ROM
  - 8-bit
  - 16-bit
  - 32-bit
- PSRAM (Cellular RAM)
  - Asynchronous mode
  - Burst mode
- NOR Flash
  - Asynchronous mode or burst mode
  - Multiplexed or nonmultiplexed

The FSMC outputs a unique chip select signal NE[4:1] per bank. All the other signals (addresses, data and control) are shared.

For synchronous accesses, the FSMC issues the clock (CLK) to the selected external device. This clock is a submultiple of the HCLK clock. The size of each bank is fixed and equal to 64 Mbytes.

Each bank is configured by means of dedicated registers (see [Section 20.6.8](#)).

The programmable memory parameters include access timings (see [Table 101](#)) and support for wait management (for PSRAM and NOR Flash accessed in burst mode).

**Table 101. Programmable NOR/PSRAM access parameters**

Parameter	Function	Access mode	Unit	Min.	Max.
Address setup	Duration of the address setup phase	Asynchronous	AHB clock cycle (HCLK)	1	16
Address hold	Duration of the address hold phase	Asynchronous, muxed I/Os	AHB clock cycle (HCLK)	2	16
Data setup	Duration of the data setup phase	Asynchronous	AHB clock cycle (HCLK)	2	256

**Table 101. Programmable NOR/PSRAM access parameters (continued)**

Parameter	Function	Access mode	Unit	Min.	Max.
Bust turn	Duration of the bus turnaround phase	Asynchronous and synchronous read	AHB clock cycle (HCLK)	1	16
Clock divide ratio	Number of AHB clock cycles (HCLK) to build one memory clock cycle (CLK)	Synchronous	AHB clock cycle (HCLK)	1	16
Data latency	Number of clock cycles to issue to the memory before the first data of the burst	Synchronous	Memory clock cycle (CLK)	2	17

## 20.5.1 External memory interface signals

[Table 102](#), [Table 103](#) and [Table 104](#) list the signals that are typically used to interface NOR Flash, SRAM and PSRAM.

*Note:* Prefix "N". specifies the associated signal as active low.

### NOR Flash, nonmultiplexed I/Os

**Table 102. Nonmuxed I/O NOR Flash**

FSMC signal name	I/O	Function
CLK	O	Clock (for synchronous burst)
A[25:0]	O	Address bus
D[15:0]	I/O	Bidirectional data bus
NE[x]	O	Chip select, x = 1..4
NOE	O	Output enable
NWE	O	Write enable
NL(=NADV)	O	Latch enable (this signal is called address valid, NADV, by some NOR Flash devices)
NWAIT	I	NOR Flash wait input signal to the FSMC

NOR Flash memories are addressed in 16-bit words. The maximum capacity is 512 Mbit (26 address lines).

### NOR Flash, multiplexed I/Os

**Table 103. Muxed I/O NOR Flash**

FSMC signal name	I/O	Function
CLK	O	Clock (for synchronous burst)
A[25:16]	O	Address bus
AD[15:0]	I/O	16-bit multiplexed, bidirectional address/data bus
NE[x]	O	Chip select, x = 1..4
NOE	O	Output enable

**Table 103. Muxed I/O NOR Flash (continued)**

FSMC signal name	I/O	Function
NWE	O	Write enable
NL(=NADV)	O	Latch enable (this signal is called address valid, NADV, by some NOR Flash devices)
NWAIT	I	NOR Flash wait input signal to the FSMC

NOR-Flash memories are addressed in 16-bit words. The maximum capacity is 512 Mbit (26 address lines).

### PSRAM/SRAM

**Table 104. Non muxed I/Os PSRAM/SRAM**

FSMC signal name	I/O	Function
CLK	O	Clock (only for PSRAM synchronous burst)
A[25:0]	O	Address bus
D[15:0]	I/O	Data bidirectional bus
NE[x]	O	Chip select, x = 1..4 (called NCE by PSRAM (Cellular RAM i.e. CRAM))
NOE	O	Output enable
NWE	O	Write enable
NL(= NADV)	O	Address valid only for PSRAM input (memory signal name: NADV)
NWAIT	I	PSRAM wait input signal to the FSMC
NBL[1]	O	Upper byte enable (memory signal name: NUB)
NBL[0]	O	Lowest byte enable (memory signal name: NLB)

PSRAM memories are addressed in 16-bit words. The maximum capacity is 512 Mbit (26 address lines).

## 20.5.2 Supported memories and transactions

[Table 105](#) below displays the supported devices, access modes and transactions. Transactions not allowed (or not supported) by the FSMC appear in gray.

**Table 105. NOR Flash/PSRAM supported memories and transactions**

Device	Mode	R/W	AHB data size	Memory data size	Allowed/not allowed	Comments
NOR Flash (muxed I/Os and nonmuxed I/Os)	Asynchronous	R	8	16	Y	
	Asynchronous	W	8	16	N	
	Asynchronous	R	16	16	Y	
	Asynchronous	W	16	16	Y	
	Asynchronous	R	32	16	Y	Split into 2 FSMC accesses
	Asynchronous	W	32	16	Y	Split into 2 FSMC accesses
	Asynchronous page	R	-	16	N	Mode is not supported
	Synchronous	R	8	16	N	
	Synchronous	R	16	16	Y	
	Synchronous	R	32	16	Y	
PSRAM (muxed I/Os and nonmuxed I/Os)	Asynchronous	R	8	16	Y	
	Asynchronous	W	8	16	Y	Use of byte lanes NBL[1:0]
	Asynchronous	R	16	16	Y	
	Asynchronous	W	16	16	Y	
	Asynchronous	R	32	16	Y	Split into 2 FSMC accesses
	Asynchronous	W	32	16	Y	Split into 2 FSMC accesses
	Asynchronous page	R	-	16	N	Mode is not supported
	Synchronous	R	8	16	N	
	Synchronous	R	16	16	Y	
	Synchronous	R	32	16	Y	
	Synchronous	W	8	16	Y	Use of byte lanes NBL[1:0]
	Synchronous	W	16/32	16	Y	
SRAM and ROM	Asynchronous	R	8 / 16 / 32	8 / 16	Y	Use of byte lanes NBL[1:0]
	Asynchronous	W	8 / 16 / 32	8 / 16	Y	Use of byte lanes NBL[1:0]

### 20.5.3 General timing rules

#### Signals synchronization

- All controller output signals change on the rising edge of the internal clock (HCLK)
- In synchronous write mode (PSRAM devices), the output data changes on the falling edge of the memory clock (CLK)

### 20.5.4 NOR Flash/PSRAM controller asynchronous transactions

#### Asynchronous static memories (NOR Flash, SRAM)

- Signals are synchronized by the internal clock HCLK. This clock is not issued to the memory
- The FSMC always samples the data before de-asserting the chip select signal NE. This guarantees that the memory data-hold timing constraint is met (chip enable high to data transition, usually 0 ns min.)
- When extended mode is set, it is possible to mix modes A, B, C and D in read and write (it is for instance possible to read in mode A and write in mode B).

#### Mode 1 - SRAM/CRAM

Figure 187. Mode1 read accesses

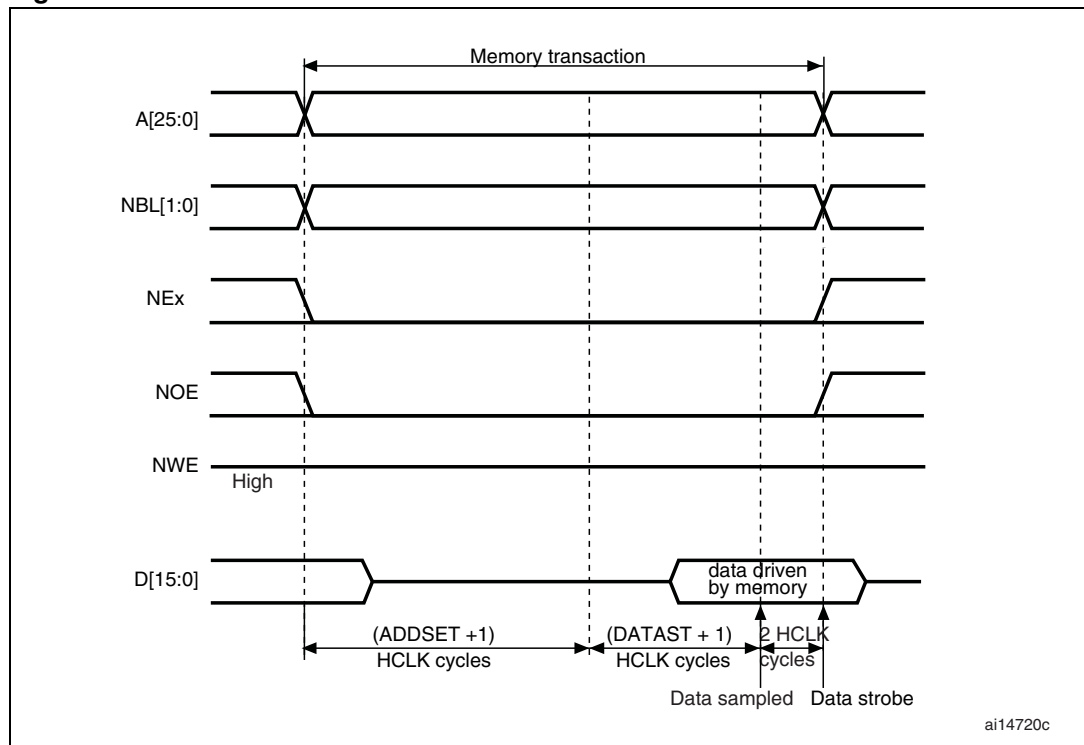
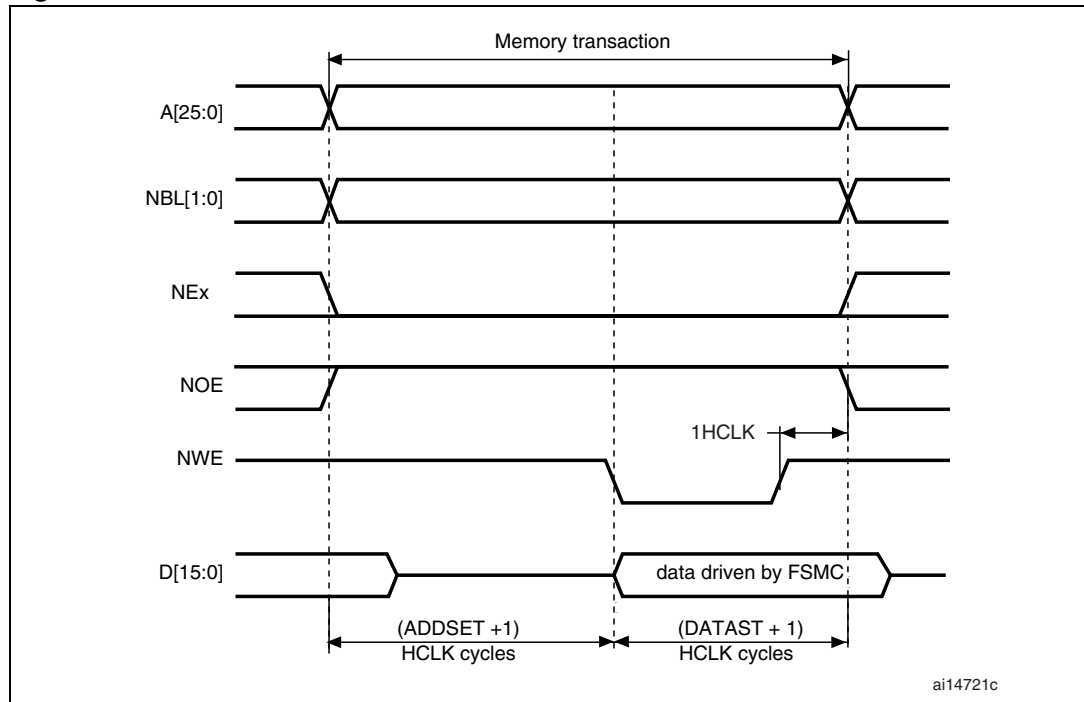




Figure 188. Mode1 write accesses



The one HCLK cycle at the end of the write transaction helps guarantee the address and data hold time after the NWE rising edge. Due to the presence of this one HCLK cycle, the DATAST value must be greater than zero ( $DATAST > 0$ ).

Table 106. FSMC\_BCRx bit fields

Bit number	Bit name	Value to set
31-16		0x0000
15	ASYNCWAIT	Set to 1 if the memory supports this feature. Otherwise keep at 0.
14-10		0x0
9	WAITPOL	Meaningful only if bit 15 is 1
8	BURSTEN	0x0
7		-
6	FACCEN	-
5-4	MWID	As needed
3-2	MTYP	As needed, exclude 10 (NOR Flash)
1	MUXEN	0x0
0	MBKEN	0x1

Table 107. FSMC\_BTRx bit fields

Bit number	Bit name	Value to set
31-16		0x0000
15-8	DATAST	Duration of the second access phase (DATAST+1 HCLK cycles for write accesses, DATAST+3 HCLK cycles for read accesses). This value cannot be 0 (minimum is 1).
7-4		0x0
3-0	ADDSET	Duration of the first access phase (ADDSET+1 HCLK cycles) .

Mode A - SRAM/PSRAM (CRAM) OE toggling

Figure 189. ModeA read accesses

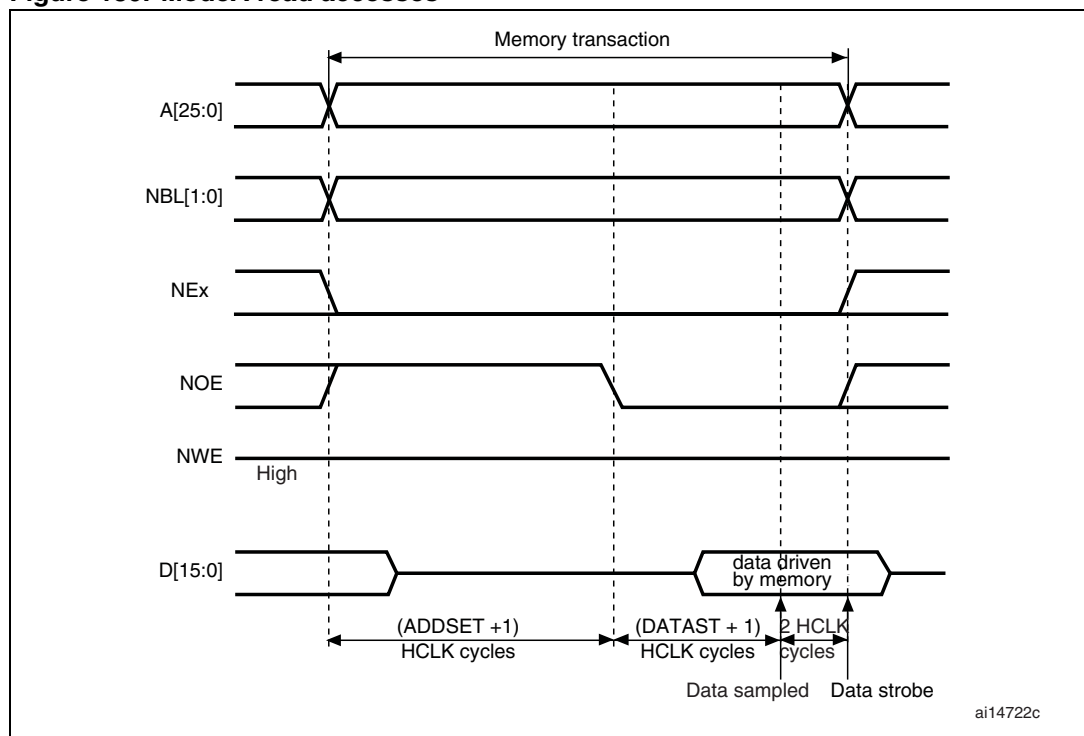
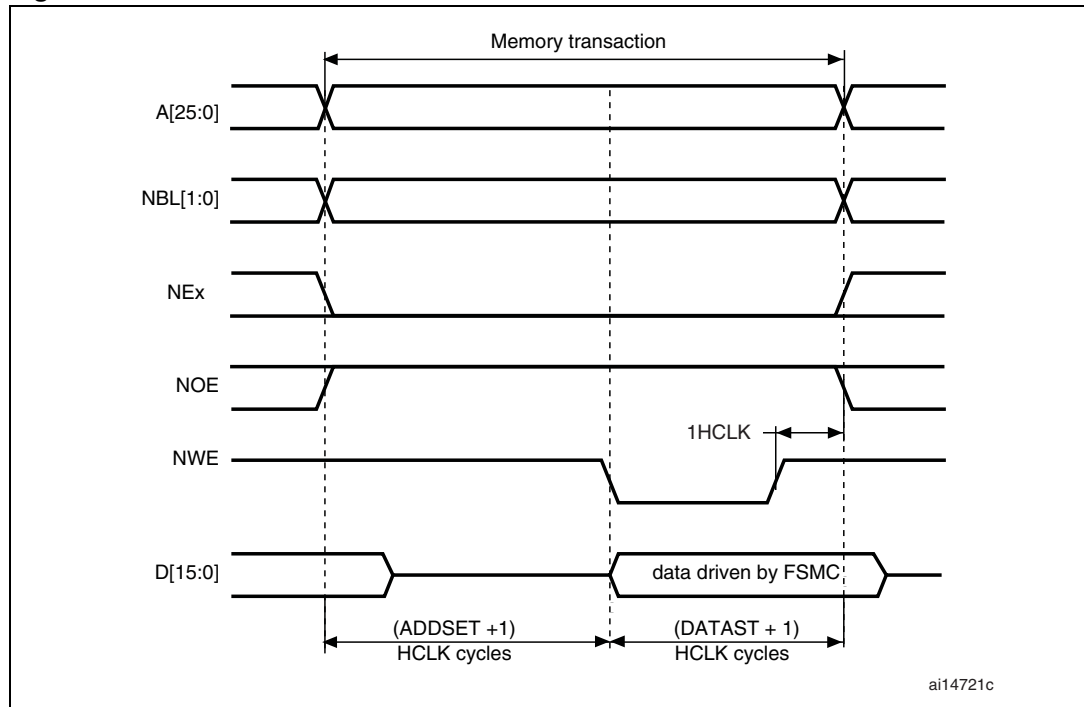


Figure 190. ModeA write accesses



The differences compared with mode1 are the toggling of NOE and the independent read and write timings.

Table 108. FSMC\_BCRx bit fields

Bit number	Bit name	Value to set
31-16		0x0000
15	ASYNCWAIT	Set to 1 if the memory supports this feature. Otherwise keep at 0.
14	EXTMOD	0x1
13-10		0x0
9	WAITPOL	Meaningful only if bit 15 is 1
8	BURSTEN	0x0
7		-
6	FACCEN	-
5-4	MWID	As needed
3-2	MTYP	As needed, exclude 10 (NOR Flash)
1	MUXEN	0x0
0	MBKEN	0x1

Table 109. FSMC\_BTRx bit fields

Bit number	Bit name	Value to set
31-30		0x0
29-28	ACCMOD	0x0
27-16		0x000
15-8	DATAST	Duration of the second access phase (DATAST+3 HCLK cycles) in read. This value cannot be 0 (minimum is 1)
7-4		0x0
3-0	ADDSET	Duration of the first access phase (ADDSET+1 HCLK cycles) in read.

Table 110. FSMC\_BWTRx bit fields

Bit number	Bit name	Value to set
31-30		0x0
29-28	ACCMOD	0x0
27-16		0x000
15-8	DATAST	Duration of the second access phase (DATAST+1 HCLK cycles) in write. This value cannot be 0 (minimum is 1).
7-4		0x0
3-0	ADDSET	Duration of the first access phase (ADDSET+1 HCLK cycles) in write

Mode 2/B - NOR Flash

Figure 191. Mode2/B read accesses

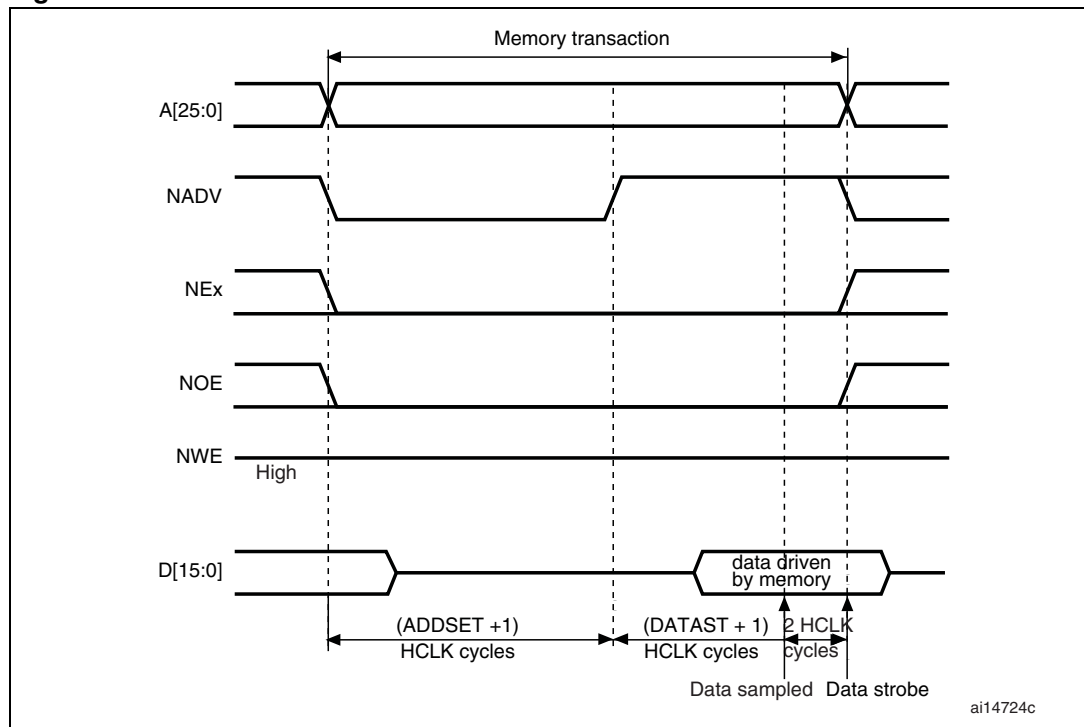


Figure 192. Mode2 write accesses

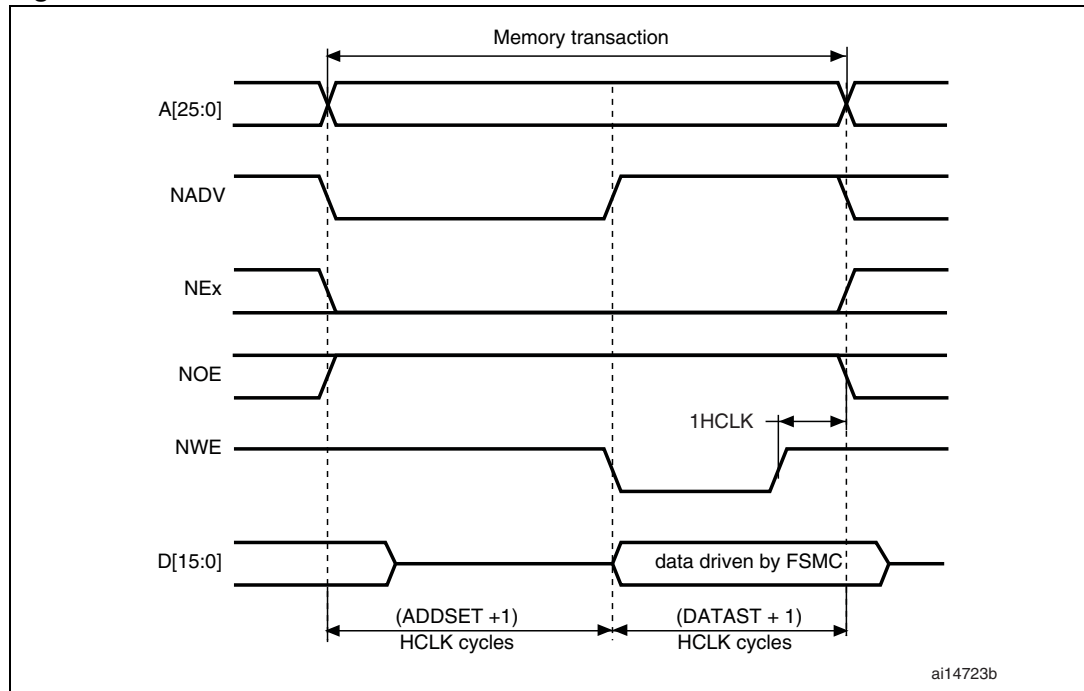
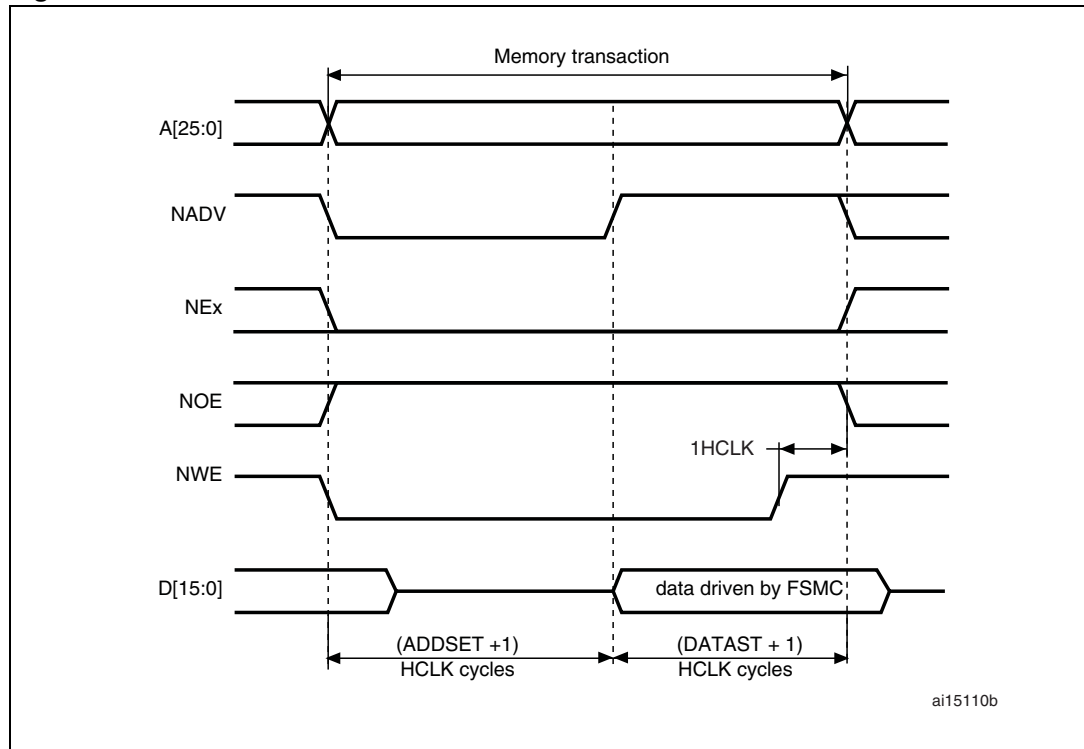


Figure 193. ModeB write accesses



The differences with mode1 are the toggling of NADV and the independent read and write timings when extended mode is set (Mode B).

Table 111. FSMC\_BCRx bit fields

Bit number	Bit name	Value to set
31-16		0x0000
15	ASYNCWAIT	Set to 1 if the memory supports this feature. Otherwise keep at 0.
14	EXTMOD	0x1 for mode B, 0x0 for mode 2
13-10		0x0
9	WAITPOL	Meaningful only if bit 15 is 1
8	BURSTEN	0x0
7		-
6	FACCEN	0x1
5-4	MWID	As needed
3-2	MTYP	10 (NOR Flash)
1	MUXEN	0x0
0	MBKEN	0x1

**Table 112. FSMC\_BTRx bit fields**

Bit number	Bit name	Value to set
31-30		0x0
29-28	ACCMOD	0x1 if extended mode is set
27-16		0x000
15-8	DATAST	Duration of the access second phase (DATAST+3 HCLK cycles) in read. This value can not be 0 (minimum is 1)
7-4		0x0
3-0	ADDSET	Duration of the access first phase (ADDSET+1 HCLK cycles) in read.

**Table 113. FSMC\_BWTRx bit fields**

Bit number	Bit name	Value to set
31-30		0x0
29-28	ACCMOD	0x1 if extended mode is set
27-16		0x000
15-8	DATAST	Duration of the access second phase (DATAST+1 HCLK cycles) in write. This value can not be 0 (minimum is 1).
7-4		0x0
3-0	ADDSET	Duration of the access first phase (ADDSET+1 HCLK cycles) in write.

*Note:* The FSMC\_BWTRx register is valid only if extended mode is set (mode B), otherwise all its content is don't care.

Mode C - NOR Flash - OE toggling

Figure 194. ModeC read accesses

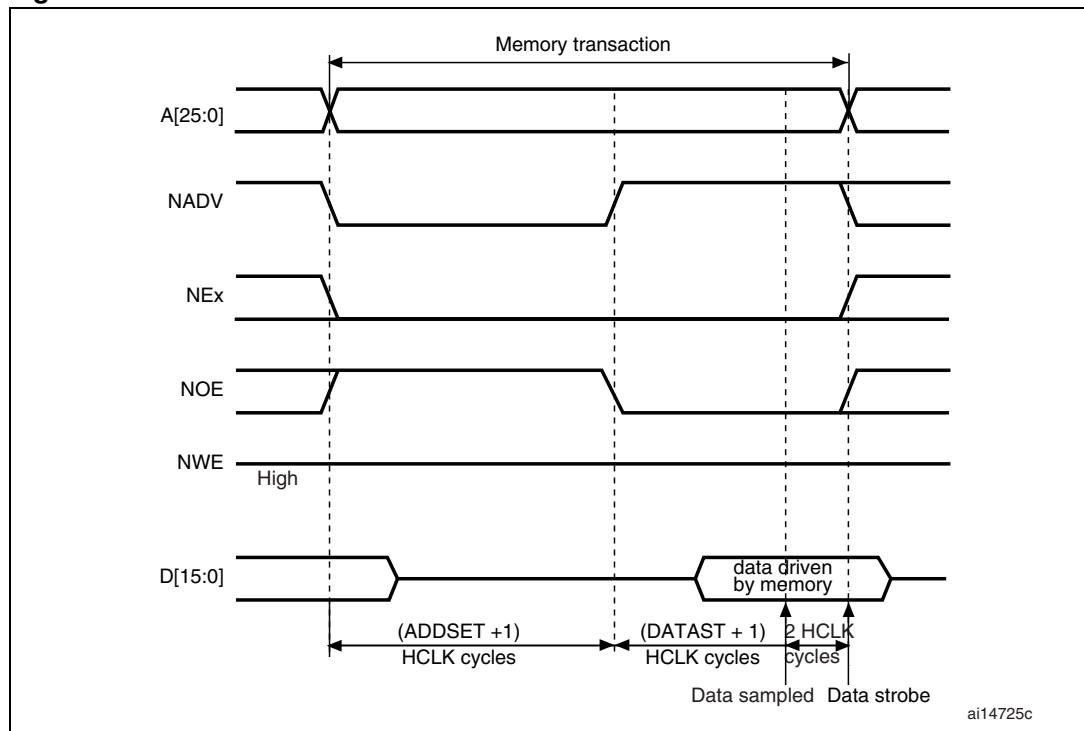
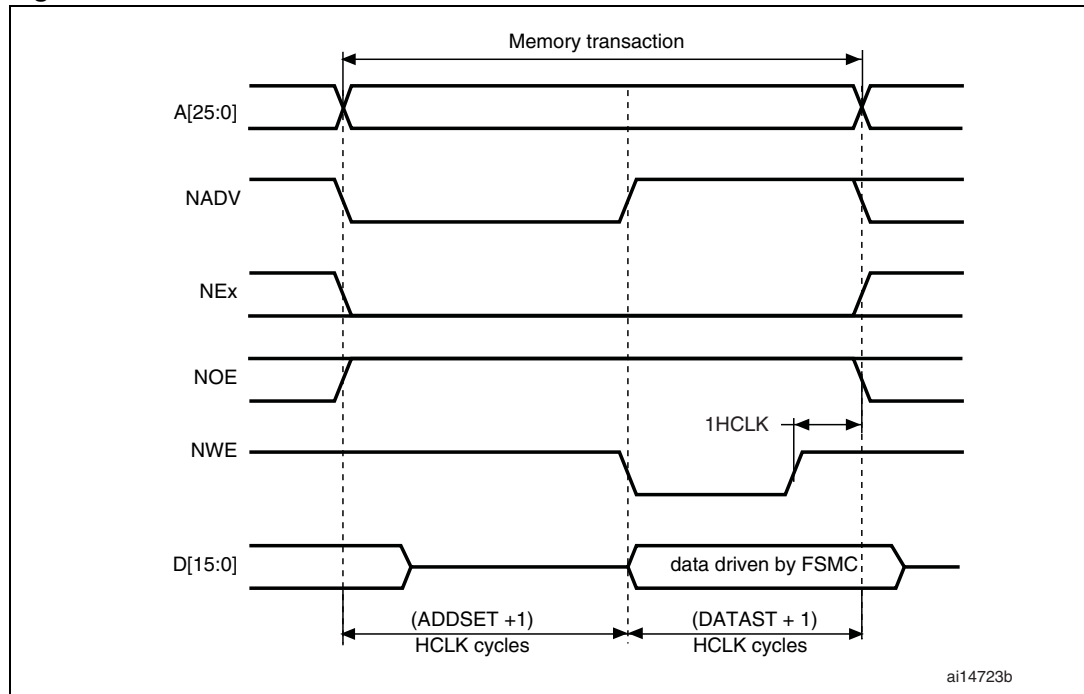


Figure 195. ModeC write accesses



The differences compared with mode1 are the toggling of NOE and NADV and the independent read and write timings.



**Table 114. FSMC\_BCRx bit fields**

Bit No.	Bit name	Value to set
31-16		0x0000
15	ASYNCWAIT	Set to 1 if the memory supports this feature. Otherwise keep at 0.
14	EXTMOD	0x1
13-10		0x0
9	WAITPOL	Meaningful only if bit 15 is 1
8	BURSTEN	0x0
7		-
6	FACCEN	1
5-4	MWID	As needed
3-2	MTYP	0x02 (NOR Flash)
1	MUXEN	0x0
0	MBKEN	0x1

**Table 115. FSMC\_BTRx bit fields**

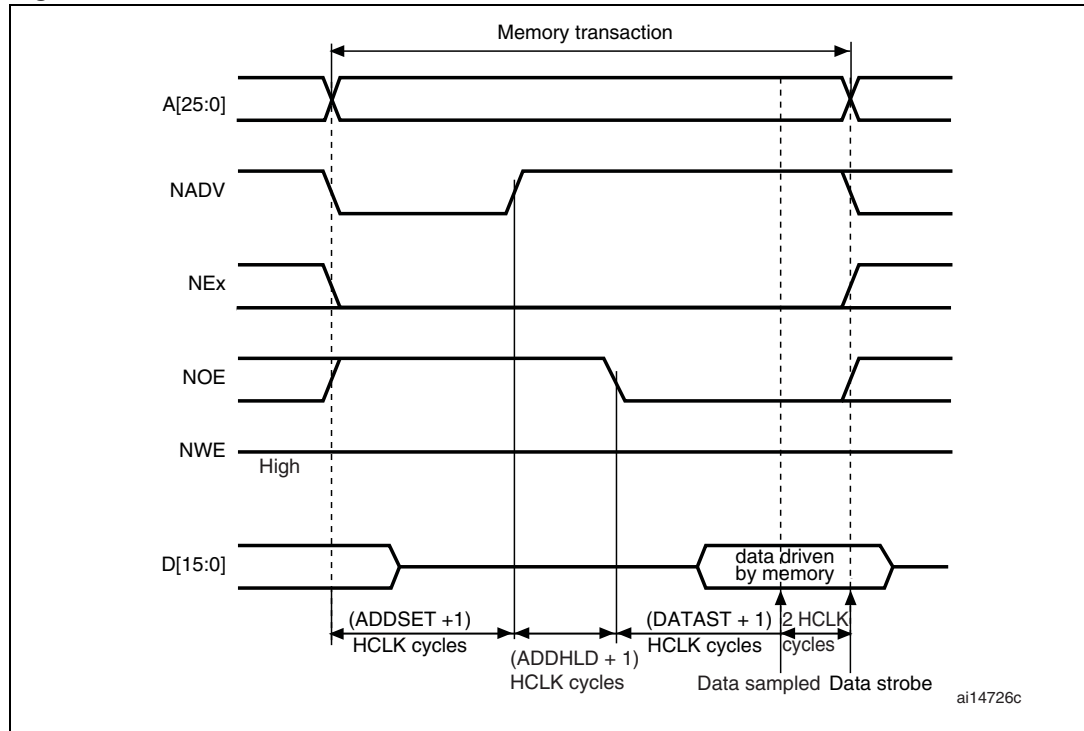
Bit No.	Bit name	Value to set
31-30		0x0
29-28	ACCMOD	0x2
27-16		0x000
15-8	DATAST	Duration of the second access phase (DATAST+3 HCLK cycles) in read. This value cannot be 0 (minimum is 1)
7-4		0x0
3-0	ADDSET	Duration of the first access phase (ADDSET+1 HCLK cycles) in read.

**Table 116. FSMC\_BWTRx bit fields**

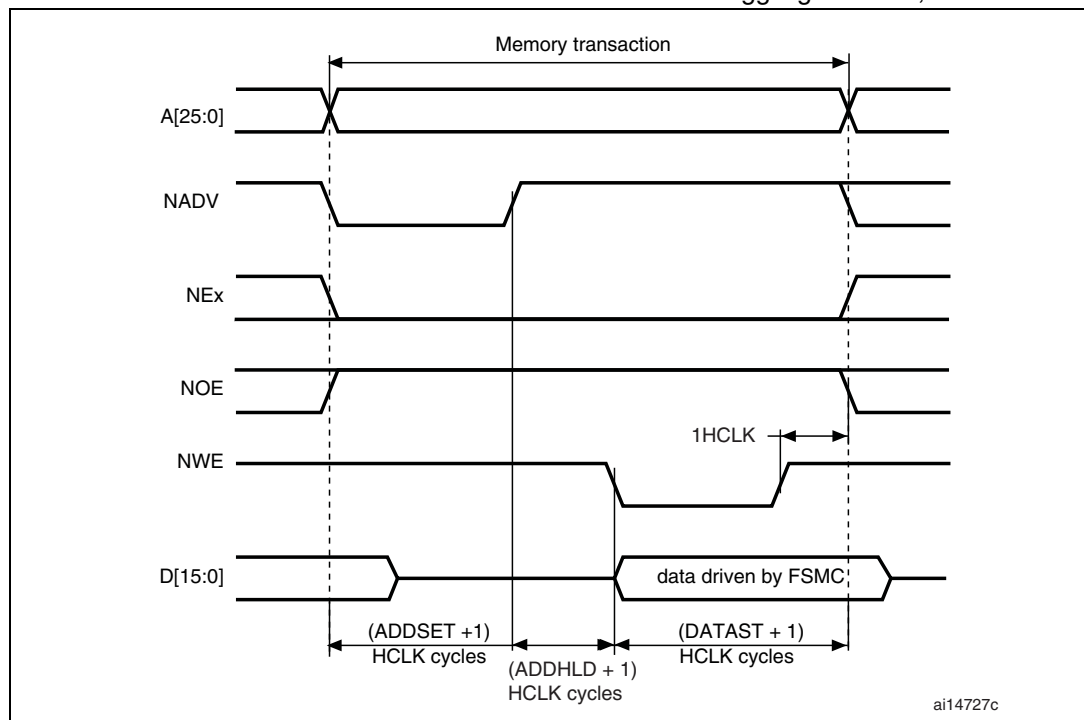
Bit No.	Bit name	Value to set
31-30		0x0
29-28	ACCMOD	0x2
27-16		0x000
15-8	DATAST	Duration of the second access phase (DATAST+1 HCLK cycles) in write. This value cannot be 0 (minimum is 1)
7-4		0x0
3-0	ADDSET	Duration of the first access phase (ADDSET+1 HCLK cycles) in write.

**Mode D - asynchronous access with extended address**

**Figure 196. ModeD read accesses**



**ModeD write accesses** The differences with mode1 are the toggling of NADV, NOE that



goes on toggling after NADV changes and the independent read and write timings.

**Table 117. FSMC\_BCRx bit fields**

Bit No.	Bit name	Value to set
31-16		0x0000
15	ASYNCWAIT	Set to 1 if the memory supports this feature. Otherwise keep at 0.
14	EXTMOD	0x1
13-10		0x0
9	WAITPOL	Meaningful only if bit 15 is 1
8	BURSTEN	0x0
7		-
6	FACCEN	Set according to memory support
5-4	MWID	As needed
3-2	MTYP	As needed
1	MUXEN	0x0
0	MBKEN	0x1

**Table 118. FSMC\_BTRx bit fields**

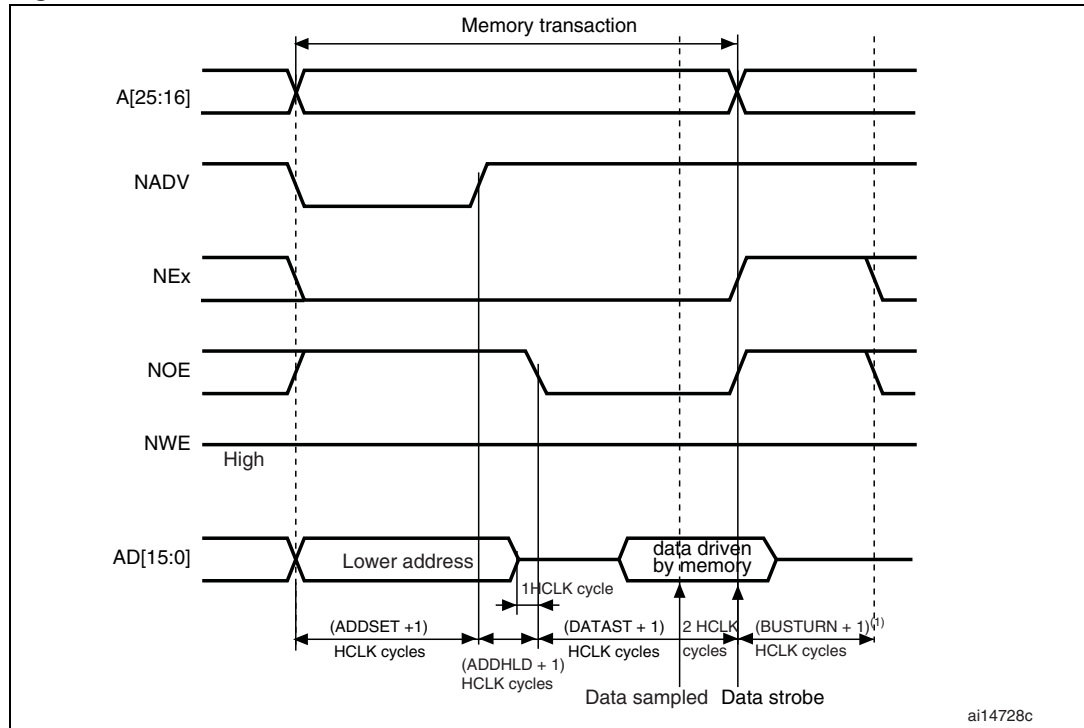
Bit No.	Bit name	Value to set
31-30		0x0
29-28	ACCMOD	0x2
27-16		0x000
15-8	DATAST	Duration of the second access phase (DATAST+3 HCLK cycles) in read. This value cannot be 0 (minimum is 1)
7-4	ADDHLD	Duration of the middle phase of the read access (ADDHLD+1 HCLK cycles)
3-0	ADDSET	Duration of the first access phase (ADDSET+1 HCLK cycles) in read.

**Table 119. FSMC\_BWTRx bit fields**

Bit No.	Bit name	Value to set
31-30		0x0
29-28	ACCMOD	0x2
27-16		0x000
15-8	DATAST	Duration of the second access phase (DATAST+1 HCLK cycles) in write. This value cannot be 0 (minimum is 1)
7-4	ADDHLD	Duration of the middle phase of the write access (ADDHLD+1 HCLK cycles)
3-0	ADDSET	Duration of the first access phase (ADDSET+1 HCLK cycles) in write.

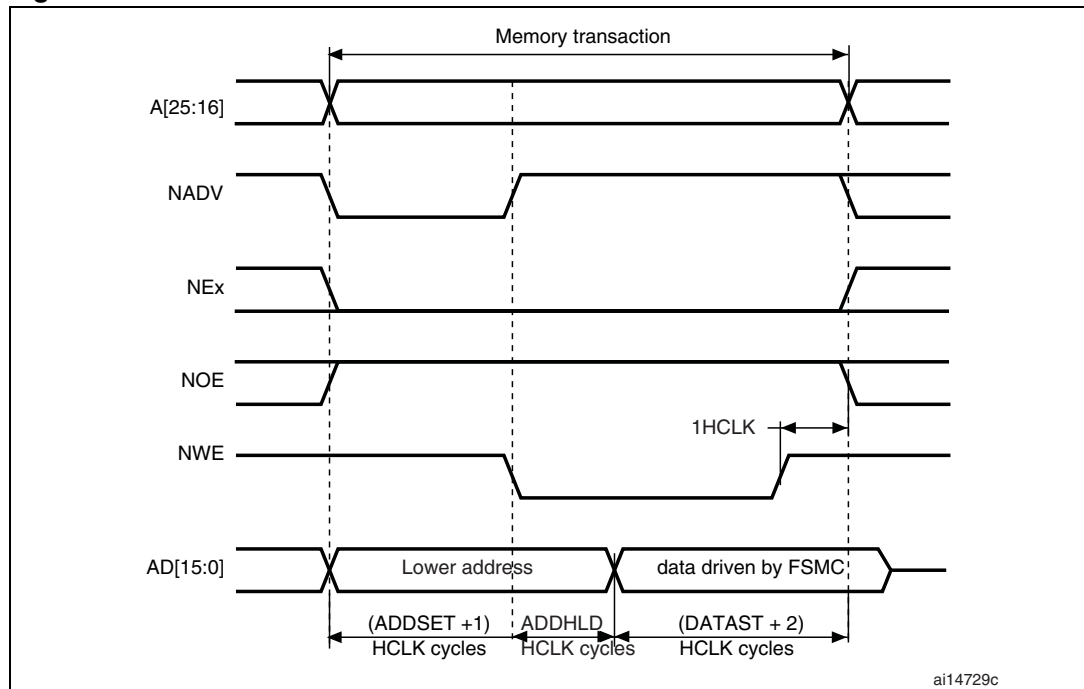
Mode mixed - asynchronous access muxed NOR Flash

Figure 197. Muxed read accesses



1. The bus turnaround delay (BUSTURN + 1) and the delay between side-by-side transactions overlap, so BUSTURN ≤ 5 has not impact.

Figure 198. Muxed write accesses



The difference with mode D is the drive of the lower address byte(s) on the databus.

**Table 120. FSMC\_BCRx bit fields**

Bit No.	Bit name	Value to set
31-16		0x0000
15	ASYNCWAIT	Set to 1 if the memory supports this feature. Otherwise keep at 0.
14	EXTMOD	0x0
13-10		0x0
9	WAITPOL	Meaningful only if bit 15 is 1
8	BURSTEN	0x0
7		-
6	FACCEN	0x1
5-4	MWID	As needed
3-2	MTYP	0x2 (NOR)
1	MUXEN	0x1
0	MBKEN	0x1

**Table 121. FSMC\_BTRx bit fields**

Bit No.	Bit name	Value to set
31-20		0x0000
19-16	BUSTURN	Duration of the last phase of the access (BUSTURN+1 HCLK)
15-8	DATAST	Duration of the second access phase (DATAST+3 HCLK cycles for read accesses and DATAST+1 HCLK cycles for write accesses). This value cannot be 0 (minimum is 1)
7-4	ADDHLD	Duration of the middle phase of the access (ADDHLD+1 HCLK cycles). This value cannot be 0 (minimum is 1).
3-0	ADDSET	Duration of the first access phase (ADDSET+1 HCLK cycles).

### WAIT management in asynchronous accesses

If the asynchronous memory asserts a WAIT signal to advise that it's not yet ready to accept or to provide data, the ASYNCWAIT bit has to be set in FSMC\_BCRx register.

If the WAIT signal is active (high or low depending on the WAITPOL bit), the second access phase (Data setup phase) programmed by the DATAST bits, is extended until WAIT becomes inactive. Unlike the data setup phase, the first access phases (Address setup and Address hold phases), programmed by the ADDSET and ADDHLD bits, are not WAIT sensitive and so they are not prolonged.

The data phase must be programmed so that WAIT can be detected 4 HCLK cycles before the end of the memory access. The following cases must be considered:

1. Memory asserts the WAIT signal aligned to NOE/NWE which toggles:  
 $data\_phase \geq 4 * HCLK + max\_wait\_assertion\_time$
2. Memory asserts the WAIT signal aligned to NEx (or NOE/NWE not toggling) :  
 if  $max\_wait\_assertion\_time > (address\_phase + hold\_phase)$   
 $data\_phase \geq 4 * HCLK + (max\_wait\_assertion\_time - address\_phase - hold\_phase)$   
 otherwise  
 $data\_phase \geq 4 * HCLK$

Where  $max\_wait\_assertion\_time$  is the maximum time taken by the memory to assert the WAIT signal once NEx/NOE/NWE is low.

The [Figure 199](#) and [Figure 200](#) show the number of HCLK clock cycles that memory access is extended after WAIT is removed by the asynchronous memory (independently of the above cases).

**Figure 199. Asynchronous wait during a read access**

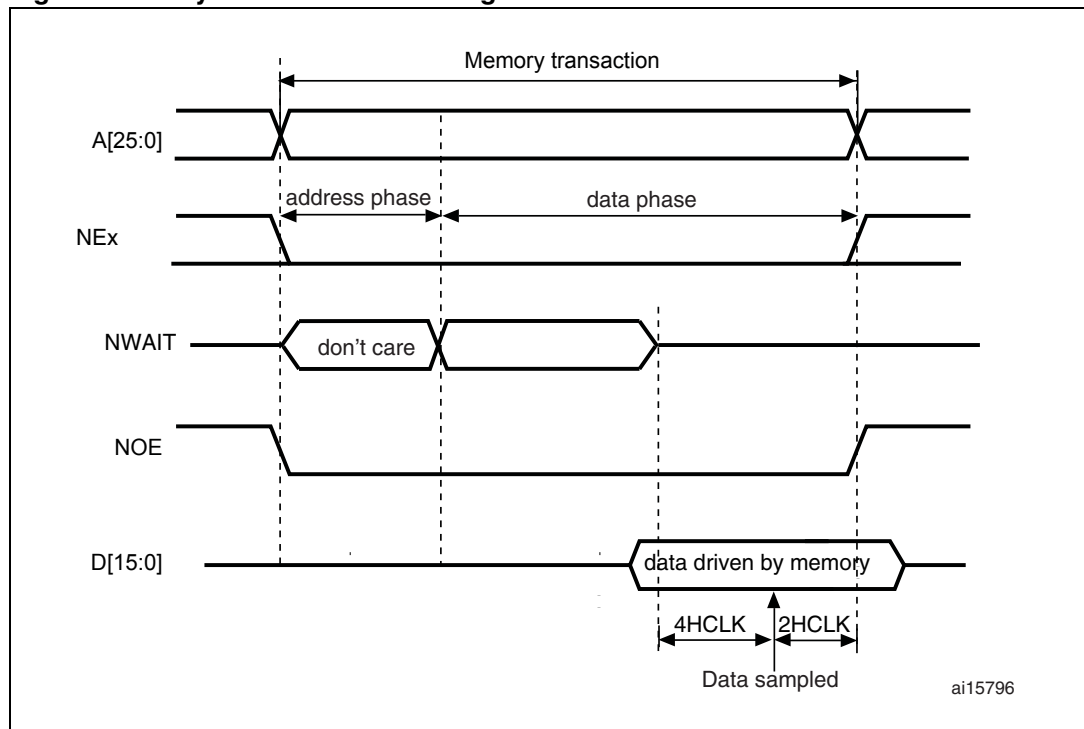
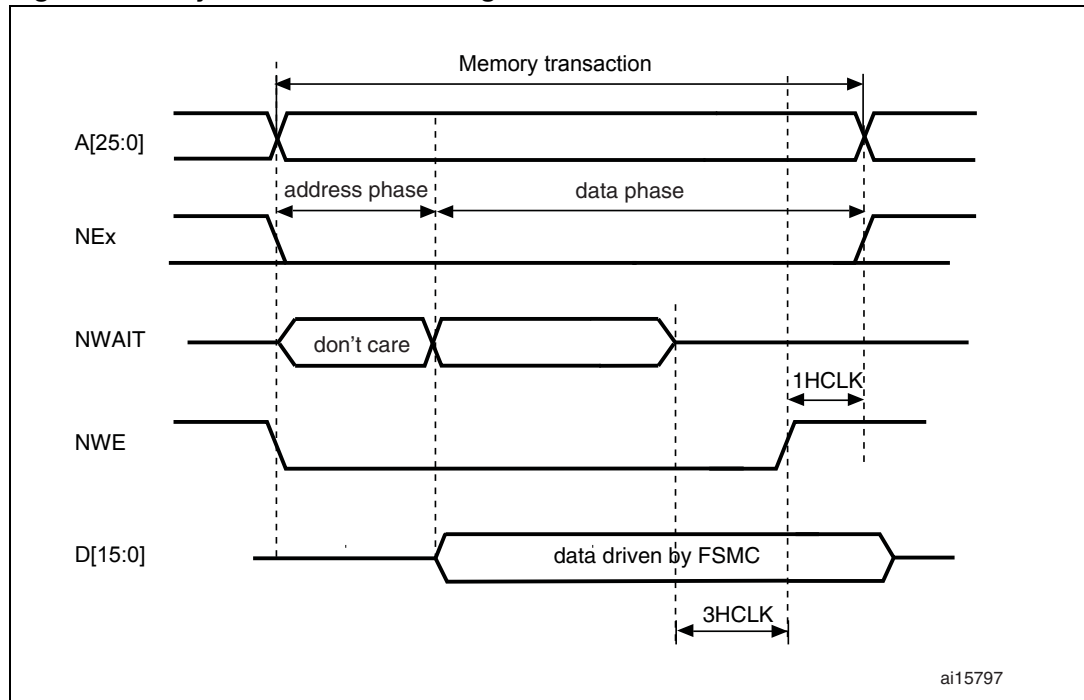


Figure 200. Asynchronous wait during a write access



### 20.5.5 Synchronous burst transactions

The memory clock, CLK, is a submultiple of HCLK according to the value of parameter CLKDIV.

NOR Flash memories specify a minimum time from NADV assertion to CLK high. To meet this constraint, the FSMC does not issue the clock to the memory during the first internal clock cycle of the synchronous access (before NADV assertion). This guarantees that the rising edge of the memory clock occurs *in the middle* of the NADV low pulse.

### Data latency versus NOR Flash latency

The data latency is the number of cycles to wait before sampling the data. The DATLAT value must be consistent with the latency value specified in the NOR Flash configuration register. The FSMC does not include the clock cycle when NADV is low in the data latency count.

**Caution:** Some NOR Flash memories include the NADV Low cycle in the data latency count, so the exact relation between the NOR Flash latency and the FSMC DATLAT parameter can be either of:

- NOR Flash latency = DATLAT + 2
- NOR Flash latency = DATLAT + 3

Some recent memories assert NWAIT during the latency phase. In such cases DATLAT can be set to its minimum value. As a result, the FSMC samples the data and waits long enough to evaluate if the data are valid. Thus the FSMC detects when the memory exits latency and real data are taken.

Other memories do not assert NWAIT during latency. In this case the latency must be set correctly for both the FSMC and the memory, otherwise invalid data are mistaken for good data, or valid data are lost in the initial phase of the memory access.

### Single-burst transfer

When the selected bank is configured in synchronous burst mode, if an AHB single-burst transaction is requested, the FSMC performs a burst transaction of length 1 (if the AHB transfer is 16-bit), or length 2 (if the AHB transfer is 32-bit) and de-assert the chip select signal when the last data is strobed.

Clearly, such a transfer is not the most efficient in terms of cycles (compared to an asynchronous read). Nevertheless, a random asynchronous access would first require to re-program the memory access mode, which would altogether last longer.

### Wait management

For synchronous burst NOR Flash, NWAIT is evaluated after the programmed latency period, (DATLAT+2) CLK clock cycles.

If NWAIT is sensed active (low level when WAITPOL = 0, high level when WAITPOL = 1), wait states are inserted until NWAIT is sensed inactive (high level when WAITPOL = 0, low level when WAITPOL = 1).

When NWAIT is inactive, the data is considered valid either immediately (bit WAITCFG = 1) or on the next clock edge (bit WAITCFG = 0).

During wait-state insertion via the NWAIT signal, the controller continues to send clock pulses to the memory, keeping the chip select and output enable signals valid, and does not consider the data valid.

There are two timing configurations for the NOR Flash NWAIT signal in burst mode:

- Flash memory asserts the NWAIT signal one data cycle before the wait state (default after reset)
- Flash memory asserts the NWAIT signal during the wait state

These two NOR Flash wait state configurations are supported by the FSMC, individually for each chip select, thanks to the WAITCFG bit in the FSMC\_BCRx registers (x = 0..3).



Figure 201. Wait configurations

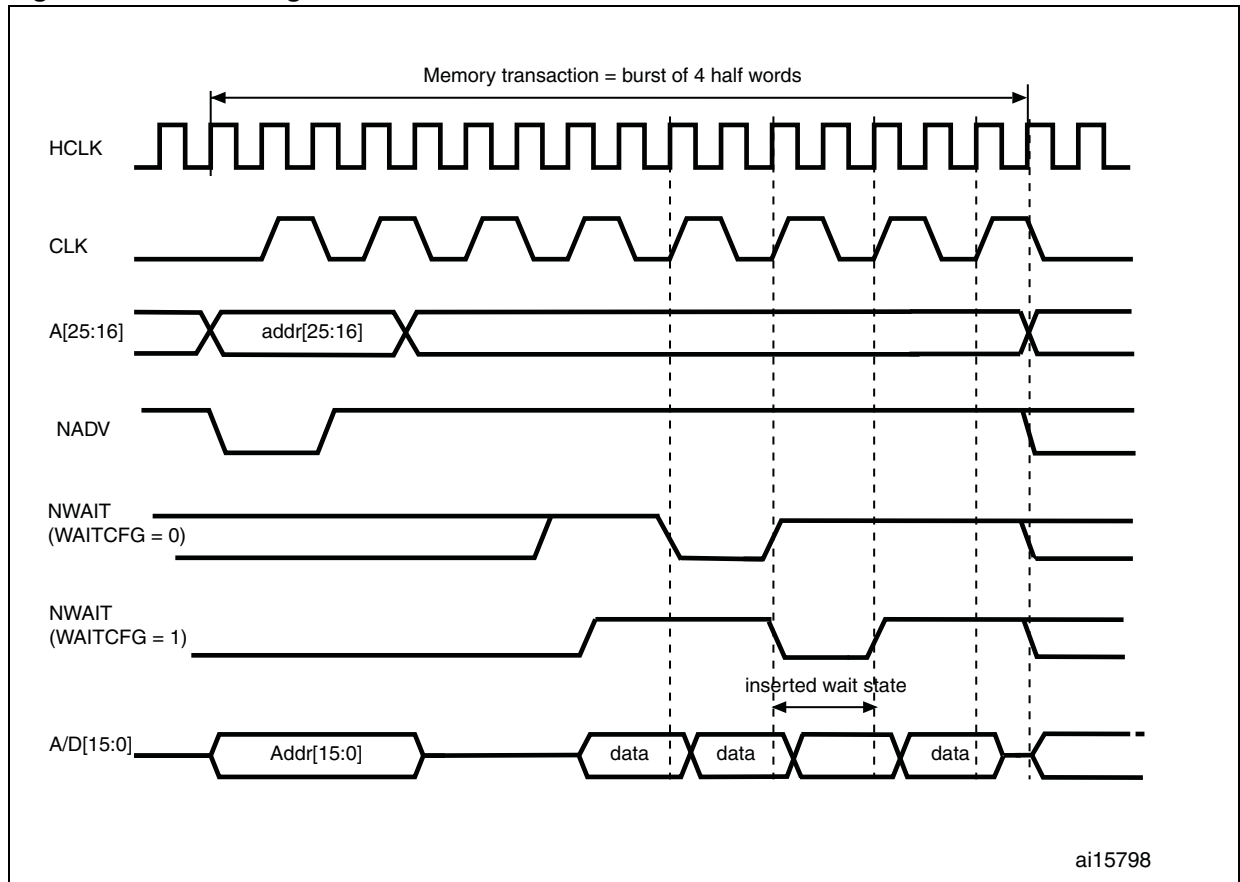
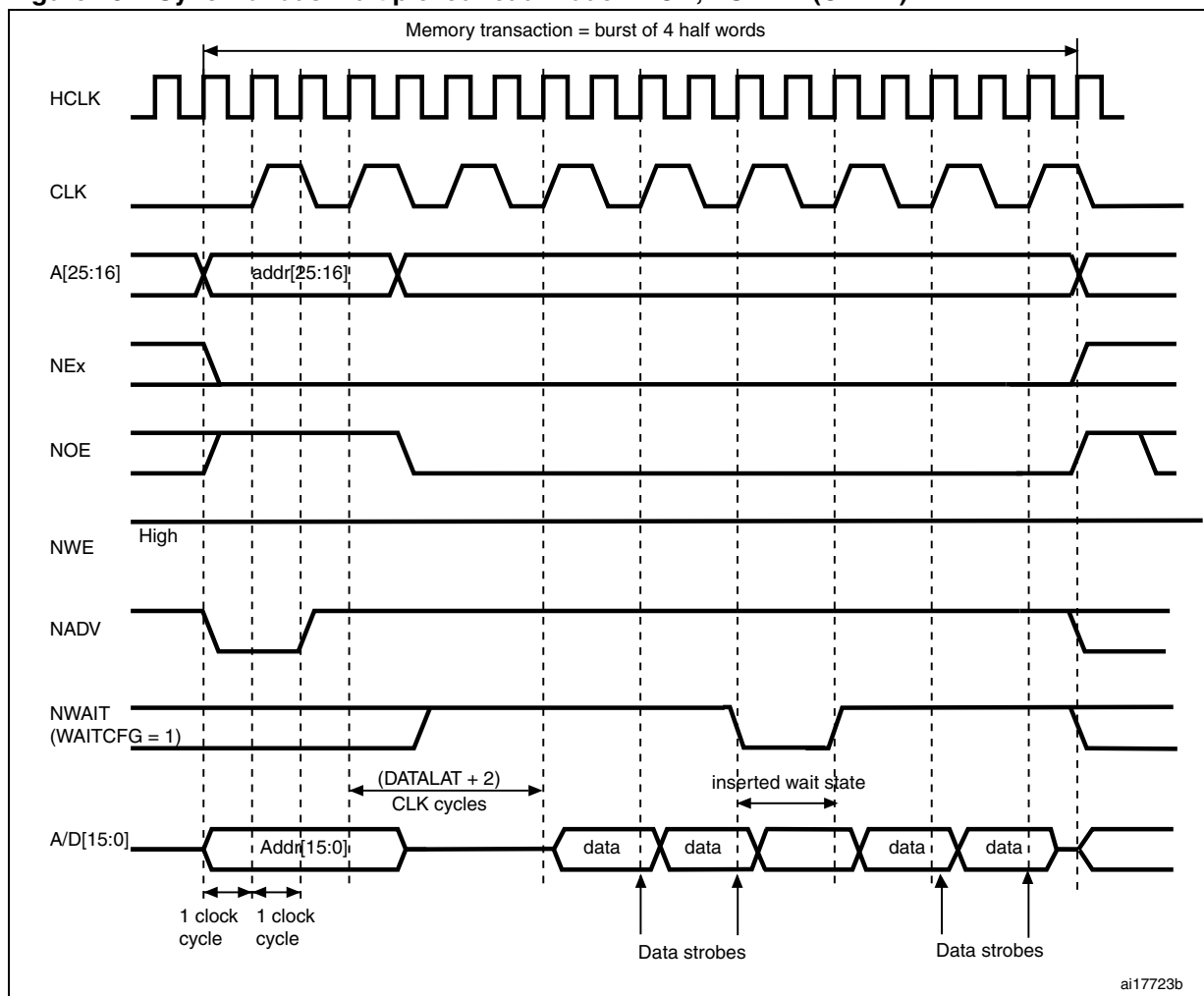


Figure 202. Synchronous multiplexed read mode - NOR, PSRAM (CRAM)



1. Byte lane outputs BL are not shown; for NOR access, they are held high, and, for PSRAM (CRAM) access, they are held low.

Table 122. FSMC\_BCRx bit fields

Bit No.	Bit name	Value to set
31-20		0x0000
19	CBURSTRW	No effect on synchronous read
18-15		0x0
14	EXTMOD	0x0
13	WAITEN	When high, the first data after latency period is taken as always valid, regardless of the wait from memory value
12	WREN	no effect on synchronous read
11	WAITCFG	to be set according to memory
10	WRAPMOD	no effect
9	WAITPOL	to be set according to memory

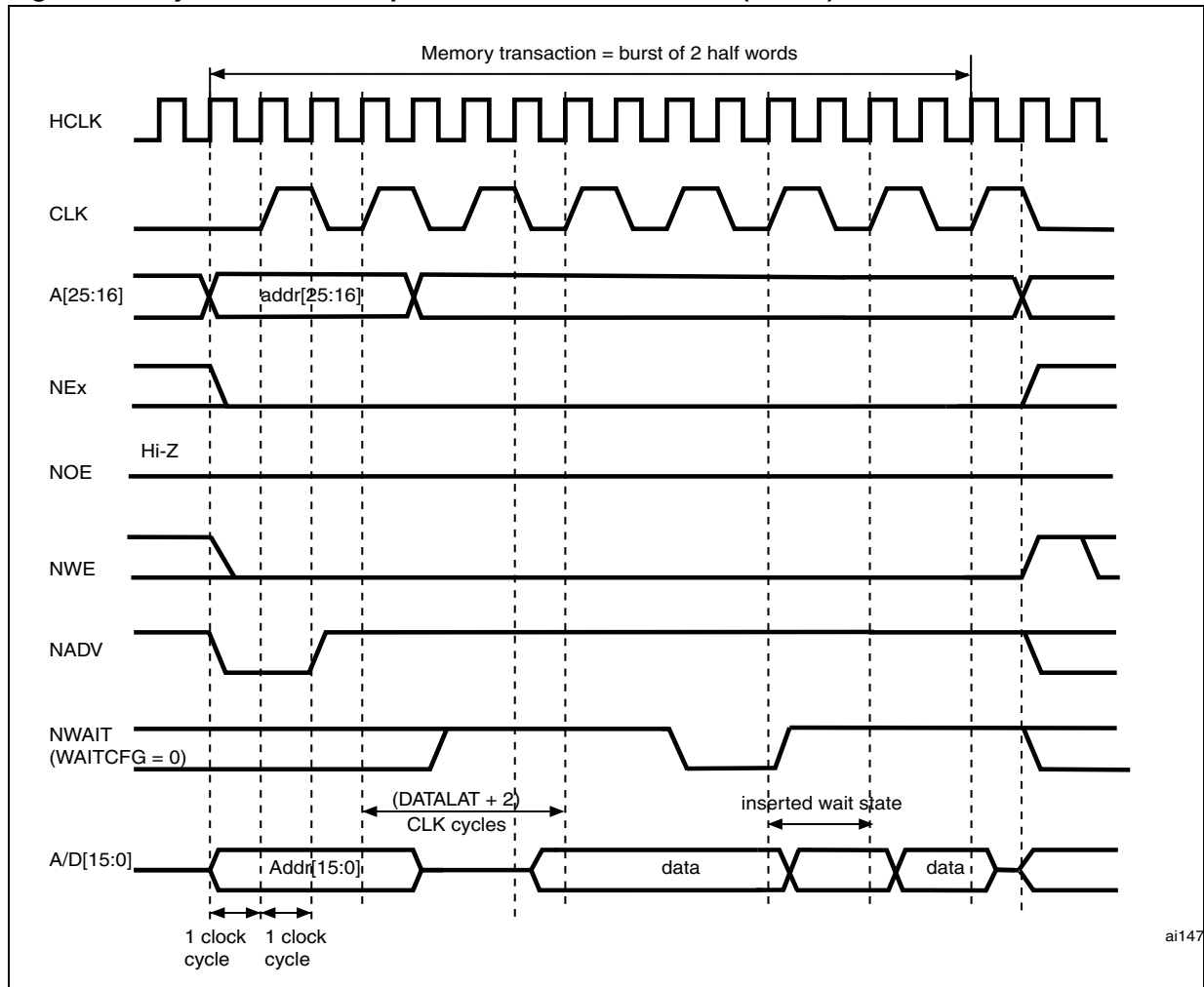
**Table 122. FSMC\_BCRx bit fields (continued)**

Bit No.	Bit name	Value to set
8	BURSTEN	0x1
7	FWPRLVL	Set to protect memory from accidental write access
6	FACCEN	Set according to memory support
5-4	MWID	As needed
3-2	MTYP	0x1 or 0x2
1	MUXEN	As needed
0	MBKEN	0x1

**Table 123. FSMC\_BTRx bit fields**

Bit No.	Bit name	Value to set
27-24	DATLAT	Data latency
23-20	CLKDIV	0x0 to get CLK = HCLK (not supported) 0x1 to get CLK = 2 × HCLK
19-16	BUSTURN	no effect
15-8	DATAS	no effect
7-4	ADDHLD	no effect
3-0	ADDSET	no effect

Figure 203. Synchronous multiplexed write mode - PSRAM (CRAM)



1. Memory must issue NWAIT signal one cycle in advance, accordingly WAITCFG must be programmed to 0.
2. Byte Lane (NBL) outputs are not shown, they are held low while NEx is active.

**Table 124. FSMC\_BCRx bit fields**

Bit No.	Bit name	Value to set
31-20		0x0000
19	CBURSTRW	0x1
18-15		0x0
14	EXTMOD	0x0
13	WAITEN	When high, the first data after latency period is taken as always valid, regardless of the wait from memory value
12	WREN	no effect on synchronous read
11	WAITCFG	0x0
10	WRAPMOD	no effect
9	WAITPOL	to be set according to memory
8	BURSTEN	no effect on synchronous write
7	FWPRLVL	Set to protect memory from accidental writes
6	FACCEN	Set according to memory support
5-4	MWID	As needed
3-2	MTYP	0x1
1	MUXEN	As needed
0	MBKEN	0x1

**Table 125. FSMC\_BTRx bit fields**

Bit No.	Bit name	Value to set
31-30	-	0x0
27-24	DATLAT	Data latency
23-20	CLKDIV	0 to get CLK = HCLK (not supported) 1 to get CLK = 2 × HCLK
19-16	BUSTURN	No effect
15-8	DATAST	No effect
7-4	ADDHLD	No effect
3-0	ADDSET	No effect

### 20.5.6 NOR/PSRAM controller registers

The peripheral registers have to be accessed by words (32-bit).

#### SRAM/NOR-Flash chip-select control registers 1..4 (FSMC\_BCR1..4)

Address offset: 0xA000 0000 + 8 \* (x - 1), x = 1...4

Reset value: 0x0000 30DX

This register contains the control information of each memory bank, used for SRAMs, ROMs and asynchronous or burst NOR Flash memories.

31	30	29	28	27	26	25	24	23	22	21	20	19	18	17	16	15	14	13	12	11	10	9	8	7	6	5	4	3	2	1	0										
Reserved												CBURSTRW	Reserved				ASYNCWAIT	EXTMOD	WAITEN	WREN	WAITCFG	WRAPMOD	WAITPOL	BURSTEN	Reserved	FACCEN	MWD		MTYP		MUXEN	MBKEN									
												rw					rw	rw	rw	rw	rw	rw	rw		rw	rw	rw	rw	rw	rw	rw	rw	rw	rw	rw	rw	rw	rw	rw	rw	rw

Bit 19 **CBURSTRW**: Write burst enable.

For Cellular RAM, the bit enables synchronous burst protocol during write operations. For Flash memory access in burst mode, this bit enables/disables the wait state insertion via the NWAIT signal. The enable bit for the synchronous burst protocol during read access is the BURSTEN bit in the FSMC\_BCRx register.

0: Write operations are always performed in asynchronous mode

1: Write operations are performed in synchronous mode.

Bit 15 **ASYNCWAIT**: Wait signal during asynchronous transfers

This bit enables the FSMC to use the wait signal even during an asynchronous protocol.

0: NWAIT signal is not taken in to account when running an asynchronous protocol (default after reset)

1: NWAIT signal is taken in to account when running an asynchronous protocol

Bit 14 **EXTMOD**: Extended mode enable.

This bit enables the FSMC to program inside the FSMC\_BWTR register, so it allows different timings for read and write.

0: values inside FSMC\_BWTR register are not taken into account (default after reset)

1: values inside FSMC\_BWTR register are taken into account

Bit 13 **WAITEN**: Wait enable bit.

For Flash memory access in burst mode, this bit enables/disables wait-state insertion via the NWAIT signal:

0: NWAIT signal is disabled (its level not taken into account, no wait state inserted after the programmed Flash latency period)

1: NWAIT signal is enabled (its level is taken into account after the programmed Flash latency period to insert wait states if asserted) (default after reset)

Bit 12 **WREN**: Write enable bit.

This bit indicates whether write operations are enabled/disabled in the bank by the FSMC:

0: Write operations are disabled in the bank by the FSMC, an AHB error is reported,

1: Write operations are enabled for the bank by the FSMC (default after reset).

- Bit 11 **WAITCFG**: Wait timing configuration.  
For memory access in burst mode, the NWAIT signal indicates whether the data from the memory are valid or if a wait state must be inserted. This configuration bit determines if NWAIT is asserted by the memory one clock cycle before the wait state or during the wait state:  
0: NWAIT signal is active one data cycle before wait state (default after reset),  
1: NWAIT signal is active during wait state (not for Cellular RAM).
- Bit 10 **WRAPMOD**: Wrapped burst mode support.  
Defines whether the controller will or not split an AHB burst wrap access into two linear accesses. Valid only when accessing memories in burst mode  
0: Direct wrapped burst is not enabled (default after reset),  
1: Direct wrapped burst is enabled.  
*Note: This bit has no effect as the CPU and DMA cannot generate wrapping burst transfers.*
- Bit 9 **WAITPOL**: Wait signal polarity bit.  
Defines the polarity of the wait signal from memory. Valid only when accessing the memory in burst mode:  
0: NWAIT active low (default after reset),  
1: NWAIT active high.
- Bit 8 **BURSTEN**: Burst enable bit.  
Enables the burst access mode for the memory. Valid only with synchronous burst memories:  
0: Burst access mode disabled (default after reset)  
1: Burst access mode enable
- Bit 7 Reserved.
- Bit 6 **FACCEN**: Flash access enable  
Enables NOR Flash memory access operations.  
0: Corresponding NOR Flash memory access is disabled  
1: Corresponding NOR Flash memory access is enabled (default after reset)
- Bits 5:4 **MWID**: Memory databus width.  
Defines the external memory device width, valid for all type of memories.  
00: 8 bits,  
01: 16 bits (default after reset),  
10: reserved, do not use,  
11: reserved, do not use.
- Bits 3:2 **MTYP**: Memory type.  
Defines the type of external memory attached to the corresponding memory bank:  
00: SRAM, ROM (default after reset for Bank 2...4)  
01: PSRAM (Cellular RAM: CRAM)  
10: NOR Flash (default after reset for Bank 1)  
11: reserved
- Bit 1 **MUXEN**: Address/data multiplexing enable bit.  
When this bit is set, the address and data values are multiplexed on the databus, valid only with NOR and PSRAM memories:  
0: Address/Data nonmultiplexed  
1: Address/Data multiplexed on databus (default after reset)
- Bit 0 **MBKEN**: Memory bank enable bit.  
Enables the memory bank. After reset Bank1 is enabled, all others are disabled. Accessing a disabled bank causes an ERROR on AHB bus.  
0: Corresponding memory bank is disabled  
1: Corresponding memory bank is enabled

**SRAM/NOR-Flash chip-select timing registers 1..4 (FSMC\_BTR1..4)**

Address offset: 0xA000 0000 + 0x04 + 8 \* (x - 1), x = 1..4

Reset value: 0x0FFF FFFF

This register contains the control information of each memory bank, used for SRAMs, ROMs and NOR Flash memories. If the EXTMOD bit is set in the FSMC\_BCRx register, then this register is partitioned for write and read access, that is, 2 registers are available: one to configure read accesses (this register) and one to configure write accesses (FSMC\_BWTRx registers).

	31	30	29	28	27	26	25	24	23	22	21	20	19	18	17	16	15	14	13	12	11	10	9	8	7	6	5	4	3	2	1	0
Reserved	ACCMOD		DATLAT				CLKDIV				BUSTURN				DATAST								ADDHLD				ADDSET					
	rw	rw	rw	rw	rw	rw	rw	rw	rw	rw	rw	rw	rw	rw	rw	rw	rw	rw	rw	rw	rw	rw	rw	rw	rw	rw	rw	rw	rw	rw	rw	rw

**Bits 29:28 ACCMOD:** Access mode

Specifies the asynchronous access modes as shown in the timing diagrams. These bits are taken into account only when the EXTMOD bit in the FSMC\_BCRx register is 1.

- 00: access mode A
- 01: access mode B
- 10: access mode C
- 11: access mode D

**Bits 27:24 DATLAT** (see note below bit descriptions): Data latency (for synchronous burst NOR Flash)

For NOR Flash with synchronous burst mode enabled, defines the number of memory clock cycles (+2) to issue to the memory before getting the first data:

This timing parameter is not expressed in HCLK periods, but in Flash clock (CLK) periods. In asynchronous NOR Flash, SRAM or ROM accesses, this value is don't care. In case of CRAM, this field must be set to 0

- 0000: Data latency of 2 CLK clock cycles for first burst access
- 1111: Data latency of 17 CLK clock cycles for first burst access (default value after reset)

**Bits 23:20 CLKDIV:** Clock divide ratio (for CLK signal)

Defines the period of CLK clock output signal, expressed in number of HCLK cycles:

- 0000: Reserved
- 0001: CLK period = 2 x HCLK periods
- 0010: CLK period = 3 x HCLK periods
- 1111: CLK period = 16 x HCLK periods (default value after reset)

In asynchronous NOR Flash, SRAM or ROM accesses, this value is don't care.

**Bits 19:16 BUSTURN:** Bus turnaround phase duration

These bits are written by software to introduce the bus turnaround delay after a read access (only from multiplexed NOR Flash memory) to avoid bus contention if the controller needs to drive addresses on the databus for the next side-by-side transaction. BUSTURN can be set to the minimum if the memory system does not include multiplexed memories or if the slowest memory does not take more than 6 HCLK clock cycles to put the databus in Hi-Z state:

- 0000: BUSTURN phase duration = 1 x HCLK clock cycle
- ...
- 1111: BUSTURN phase duration = 16 x HCLK clock cycles (default value after reset)



Bits 15:8 **DATAST**: Data-phase duration

These bits are written by software to define the duration of the data phase (refer to [Figure 187](#) to [Figure 198](#)), used in SRAMs, ROMs and asynchronous multiplexed NOR Flash accesses:

0000 0000: Reserved

0000 0001: DATAST phase duration = 2 × HCLK clock cycles

0000 0010: DATAST phase duration = 3 × HCLK clock cycles

...

1111 1111: DATAST phase duration = 256 × HCLK clock cycles (default value after reset)

For each memory type and access mode data-phase duration, please refer to the respective figure ([Figure 187](#) to [Figure 198](#)).

Example: Mode1, read access, DATAST=1: Data-phase duration= DATAST+3 = 4 HCLK clock cycles.

Bits 7:4 **ADDHLD**: Address-hold phase duration

These bits are written by software to define the duration of the *address hold* phase (refer to [Figure 196](#) to [Figure 198](#)), used in mode D and multiplexed accesses:

0000: Reserved

0001: ADDHLD phase duration = 2 × HCLK clock cycle

0010: ADDHLD phase duration = 3 × HCLK clock cycle

...

1111: ADDHLD phase duration = 16 × HCLK clock cycles (default value after reset)

For each access mode address-hold phase duration, please refer to the respective figure ([Figure 196](#) to [Figure 198](#)).

Example: ModeD, read access, ADDHLD=1: Address-hold phase duration = ADDHLD + 1 = 2 HCLK clock cycles.

*Note: In synchronous accesses, this value is not used, the address hold phase is always 1 memory clock period duration.*

Bits 3:0 **ADDSET**: Address setup phase duration

These bits are written by software to define the duration of the *address setup* phase (refer to [Figure 187](#) to [Figure 198](#)), used in SRAMs, ROMs and asynchronous NOR Flash:

0000: ADDSET phase duration = 1 × HCLK clock cycle

...

1111: ADDSET phase duration = 16 × HCLK clock cycles (default value after reset)

For each access mode address setup phase duration, please refer to the respective figure (refer to [Figure 187](#) to [Figure 198](#)).

Example: Mode2, read access, ADDSET=1: Address setup phase duration = ADDSET + 1 = 2 HCLK clock cycles.

*Note: In synchronous accesses, this value is not used, the address hold phase is always 1 memory clock period duration.*

*Note: PSRAMs (CRAMs) have a variable latency due to internal refresh. Therefore these memories issue the NWAIT signal during the whole latency phase to prolong the latency as needed.*

*With PSRAMs (CRAMs) the filed DATLAT must be set to 0, so that the FSMC exits its latency phase soon and starts sampling NWAIT from memory, then starts to read or write when the memory is ready.*

*This method can be used also with the latest generation of synchronous Flash memories that issue the NWAIT signal, unlike older Flash memories (check the datasheet of the specific Flash memory being used).*

**SRAM/NOR-Flash write timing registers 1..4 (FSMC\_BWTR1..4)**

Address offset: 0xA000 0000 + 0x104 \* (x - 1), x = 1...4

Reset value: 0x0FFF FFFF

This register contains the control information of each memory bank, used for SRAMs, ROMs and NOR Flash memories. When the EXTMOD bit is set in the FSMC\_BCRx register, then this register is active for write access.

31	30	29	28	27	26	25	24	23	22	21	20	19	18	17	16	15	14	13	12	11	10	9	8	7	6	5	4	3	2	1	0	
Res.		ACCMOD		DATLAT				CLKDIV				Reserved								DATAST				ADDHLD				ADDSET				
		rw	rw	rw	rw	rw	rw	rw	rw	rw	rw																					

Bits 29:28 **ACCMOD**: Access mode.

Specifies the asynchronous access modes as shown in the next timing diagrams. These bits are taken into account only when the EXTMOD bit in the FSMC\_BCRx register is 1.

- 00: access mode A
- 01: access mode B
- 10: access mode C
- 11: access mode D

Bits 27:24 **DATLAT**: Data latency (for synchronous burst NOR Flash).

For NOR Flash with Synchronous burst mode enabled, defines the number of memory clock cycles (+2) to issue to the memory before getting the first data:

0000: (0x0) Data latency of 2 CLK clock cycles for first burst access

...

1111: (0xF) Data latency of 17 CLK clock cycles for first burst access (default value after reset)

*Note: This timing parameter is not expressed in HCLK periods, but in Flash clock (CLK) periods*

*Note: In asynchronous NOR Flash, SRAM or ROM accesses, this value is don't care.*

*Note: In case of CRAM, this field must be set to 0*

Bits 23:20 **CLKDIV**: Clock divide ratio (for CLK signal).

Defines the period of CLK clock output signal, expressed in number of HCLK cycles:

0000: Reserved

0001 CLK period = 2 × HCLK periods

0010 CLK period = 3 × HCLK periods

1111: CLK period = 16 × HCLK periods (default value after reset)

In asynchronous NOR Flash, SRAM or ROM accesses, this value is don't care.

Bits 19:16 Reserved

Bits 15:8 **DATAST**: Data-phase duration.

These bits are written by software to define the duration of the data phase (refer to [Figure 187](#) to [Figure 198](#)), used in SRAMs, ROMs and asynchronous multiplexed NOR Flash accesses:

0000 0000: Reserved

0000 0001: DATAST phase duration = 2 × HCLK clock cycles

0000 0010: DATAST phase duration = 3 × HCLK clock cycles

...

1111 1111: DATAST phase duration = 16 × HCLK clock cycles (default value after reset)

Bits 7:4 **ADDHLD**: Address-hold phase duration.

These bits are written by software to define the duration of the *address hold* phase (refer to [Figure 196](#) to [Figure 198](#)), used in SRAMs, ROMs and asynchronous multiplexed NOR Flash accesses:

0000: Reserved

0001: ADDHLD phase duration = 2 × HCLK clock cycle

0010: ADDHLD phase duration = 3 × HCLK clock cycle

...

1111: ADDHLD phase duration = 16 × HCLK clock cycles (default value after reset)

*Note: In synchronous NOR Flash accesses, this value is not used, the address hold phase is always 1 Flash clock period duration.*

Bits 3:0 **ADDSET**: Address setup phase duration.

These bits are written by software to define the duration of the *address setup* phase in HCLK cycles (refer to [Figure 196](#) to [Figure 198](#)), used in SRAMs, ROMs and asynchronous multiplexed NOR Flash:

0000: ADDSET phase duration = 1 × HCLK clock cycle

...

1111: ADDSET phase duration = 16 × HCLK clock cycles (default value after reset)

*Note: In synchronous NOR Flash accesses, this value is not used, the address hold phase is always 1 Flash clock period duration.*

## 20.6 NAND Flash/PC Card controller

The FSMC generates the appropriate signal timings to drive the following types of device:

- NAND Flash
  - 8-bit
  - 16-bit
- 16-bit PC Card compatible devices

The NAND/PC Card controller can control three external banks. Bank 2 and bank 3 support NAND Flash devices. Bank 4 supports PC Card devices.

Each bank is configured by means of dedicated registers ([Section 20.6.8](#)). The programmable memory parameters include access timings (shown in [Table 126](#)) and ECC configuration.

**Table 126. Programmable NAND/PC Card access parameters**

Parameter	Function	Access mode	Unit	Min.	Max.
Memory setup time	Number of clock cycles (HCLK) to set up the address before the command assertion	Read/Write	AHB clock cycle (HCLK)	1	256
Memory wait	Minimum duration (HCLK clock cycles) of the command assertion	Read/Write	AHB clock cycle (HCLK)	2	256
Memory hold	Number of clock cycles (HCLK) to hold the address (and the data in case of a write access) after the command de-assertion	Read/Write	AHB clock cycle (HCLK)	1	255
Memory databus high-Z	Number of clock cycles (HCLK) during which the databus is kept in high-Z state after the start of a write access	Write	AHB clock cycle (HCLK)	0	255

### 20.6.1 External memory interface signals

The following tables list the signals that are typically used to interface NAND Flash and PC Card.

**Caution:** When using a PC Card or a CompactFlash in I/O mode, the NIOS16 input pin must remain at ground level during the whole operation, otherwise the FSMC may not operate properly. This means that the NIOS16 input pin must *not* be connected to the card, but directly to ground (only 16-bit accesses are allowed).

*Note:* Prefix "N" specifies the associated signal as active low.

#### 8-bit NAND Flash

**Table 127. 8-bit NAND Flash**

FSMC signal name	I/O	Function
A[17]	O	NAND Flash address latch enable (ALE) signal
A[16]	O	NAND Flash command latch enable (CLE) signal
D[7:0]	I/O	8-bit multiplexed, bidirectional address/data bus
NCE[x]	O	Chip select, x = 2, 3
NOE(= NRE)	O	Output enable (memory signal name: read enable, NRE)
NWE	O	Write enable
NWAIT/INT[3:2]	I	NAND Flash ready/busy input signal to the FSMC

There is no theoretical capacity limitation as the FSMC can manage as many address cycles as needed.

## 16-bit NAND Flash

**Table 128. 16-bit NAND Flash**

FSMC signal name	I/O	Function
A[17]	O	NAND Flash address latch enable (ALE) signal
A[16]	O	NAND Flash command latch enable (CLE) signal
D[15:0]	I/O	16-bit multiplexed, bidirectional address/data bus
NCE[x]	O	Chip select, x = 2, 3
NOE(= NRE)	O	Output enable (memory signal name: read enable, NRE)
NWE	O	Write enable
NWAIT/INT[3:2]	I	NAND Flash ready/busy input signal to the FSMC

There is no theoretical capacity limitation as the FSMC can manage as many address cycles as needed.

**Table 129. 16-bit PC Card**

FSMC signal name	I/O	Function
A[10:0]	O	Address bus
NIOS16	I	Data transfer in I/O space. It must be shorted to GND (16-bit transfer only)
NIORD	O	Output enable for I/O space
NIOWR	O	Write enable for I/O space
NREG	O	Register signal indicating if access is in Common or Attribute space
D[15:0]	I/O	Bidirectional databus
NCE4_1	O	Chip select 1
NCE4_2	O	Chip select 2 (indicates if access is 16-bit or 8-bit)
NOE	O	Output enable in Common and in Attribute space
NWE	O	Write enable in Common and in Attribute space
NWAIT	I	PC Card wait input signal to the FSMC (memory signal name IORDY)
INTR	I	PC Card interrupt to the FSMC (only for PC Cards that can generate an interrupt)
CD	I	PC Card presence detection. Active high. If an access is performed to the PC Card banks while CD is low, an AHB error is generated. Refer to <a href="#">Section 20.3: AHB interface</a>

## 20.6.2 NAND Flash / PC Card supported memories and transactions

*Table 130* below shows the supported devices, access modes and transactions. Transactions not allowed (or not supported) by the NAND Flash / PC Card controller appear in gray.

**Table 130. Supported memories and transactions**

Device	Mode	R/W	AHB data size	Memory data size	Allowed/not allowed	Comments
NAND 8-bit	Asynchronous	R	8	8	Y	
	Asynchronous	W	8	8	Y	
	Asynchronous	R	16	8	Y	Split into 2 FSMC accesses
	Asynchronous	W	16	8	Y	Split into 2 FSMC accesses
	Asynchronous	R	32	8	Y	Split into 4 FSMC accesses
	Asynchronous	W	32	8	Y	Split into 4 FSMC accesses
NAND 16-bit	Asynchronous	R	8	16	Y	
	Asynchronous	W	8	16	N	
	Asynchronous	R	16	16	Y	
	Asynchronous	W	16	16	Y	
	Asynchronous	R	32	16	Y	Split into 2 FSMC accesses
	Asynchronous	W	32	16	Y	Split into 2 FSMC accesses

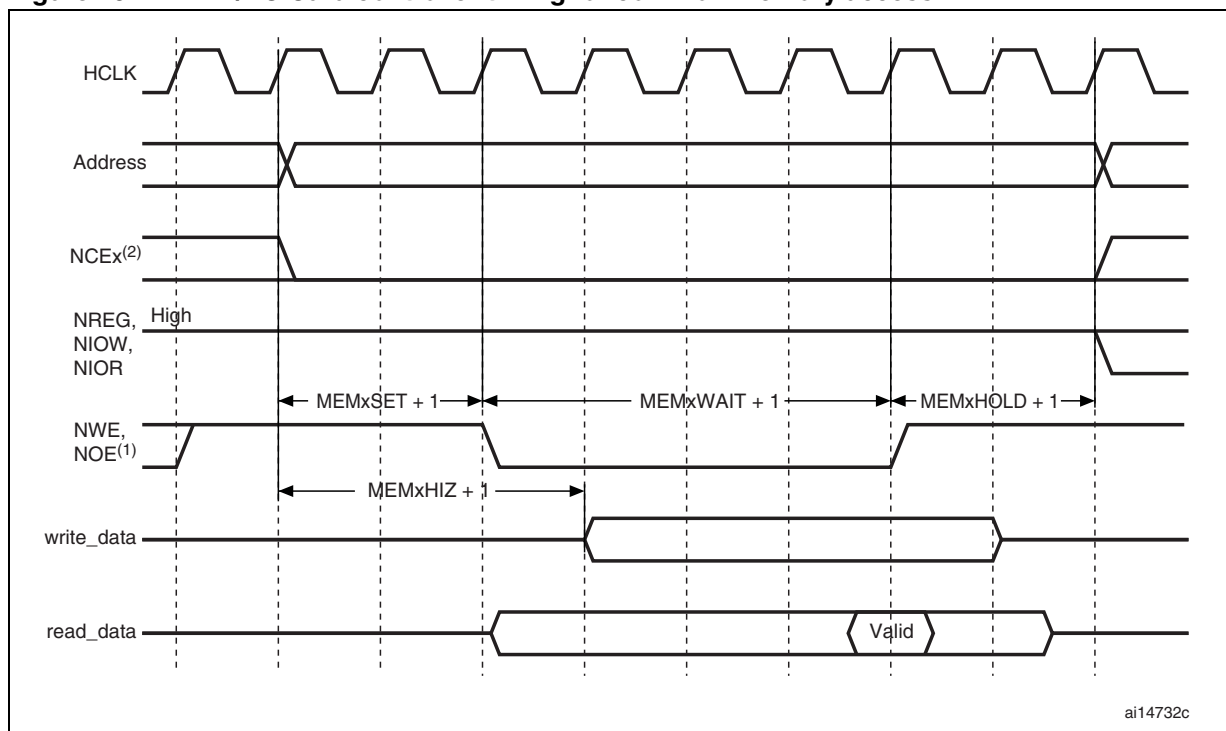
## 20.6.3 Timing diagrams for NAND and PC Card

Each PC Card/CompactFlash and NAND Flash memory bank is managed through a set of registers:

- Control register: FSMC\_PCRx
- Interrupt status register: FSMC\_SRx
- ECC register: FSMC\_ECCRx
- Timing register for Common memory space: FSMC\_PMEMx
- Timing register for Attribute memory space: FSMC\_PATTx
- Timing register for I/O space: FSMC\_PIOx

Each timing configuration register contains three parameters used to define number of HCLK cycles for the three phases of any PC Card/CompactFlash or NAND Flash access, plus one parameter that defines the timing for starting driving the databus in the case of a write. *Figure 204* shows the timing parameter definitions for common memory accesses, knowing that Attribute and I/O (only for PC Card) memory space access timings are similar.

Figure 204. NAND/PC Card controller timing for common memory access



1. NOE remains high (inactive) during write access. NWE remains high (inactive) during read access.
2. NCEx goes low as soon as NAND access is requested and remains low until a different memory bank is accessed.

### 20.6.4 NAND Flash operations

The command latch enable (CLE) and address latch enable (ALE) signals of the NAND Flash device are driven by some address signals of the FSMC controller. This means that to send a command or an address to the NAND Flash memory, the CPU has to perform a write to a certain address in its memory space.

A typical page read operation from the NAND Flash device is as follows:

1. Program and enable the corresponding memory bank by configuring the FSMC\_PCRx and FSMC\_PMEMx (and for some devices, FSMC\_PATTx, see [Section 20.6.5: NAND Flash pre-wait functionality on page 512](#)) registers according to the characteristics of the NAND Flash (PWID bits for the databus width of the NAND Flash, PTYP = 1, PWAITEN = 1, PBKEN = 1, see section [Common memory space timing register 2..4 \(FSMC\\_PMEM2..4\) on page 518](#) for timing configuration).
2. The CPU performs a byte write in the common memory space, with data byte equal to one Flash command byte (for example 0x00 for Samsung NAND Flash devices). The CLE input of the NAND Flash is active during the write strobe (low pulse on NWE), thus the written byte is interpreted as a command by the NAND Flash. Once the command is latched by the NAND Flash device, it does not need to be written for the following page read operations.
3. The CPU can send the start address (STARTAD) for a read operation by writing four bytes (or three for smaller capacity devices), STARTAD[7:0], then STARTAD[16:9], STARTAD[24:17] and finally STARTAD[25] for 64 Mb x 8 bit NAND Flash) in the common memory or attribute space. The ALE input of the NAND Flash device is active during the write strobe (low pulse on NWE), thus the written bytes are interpreted as

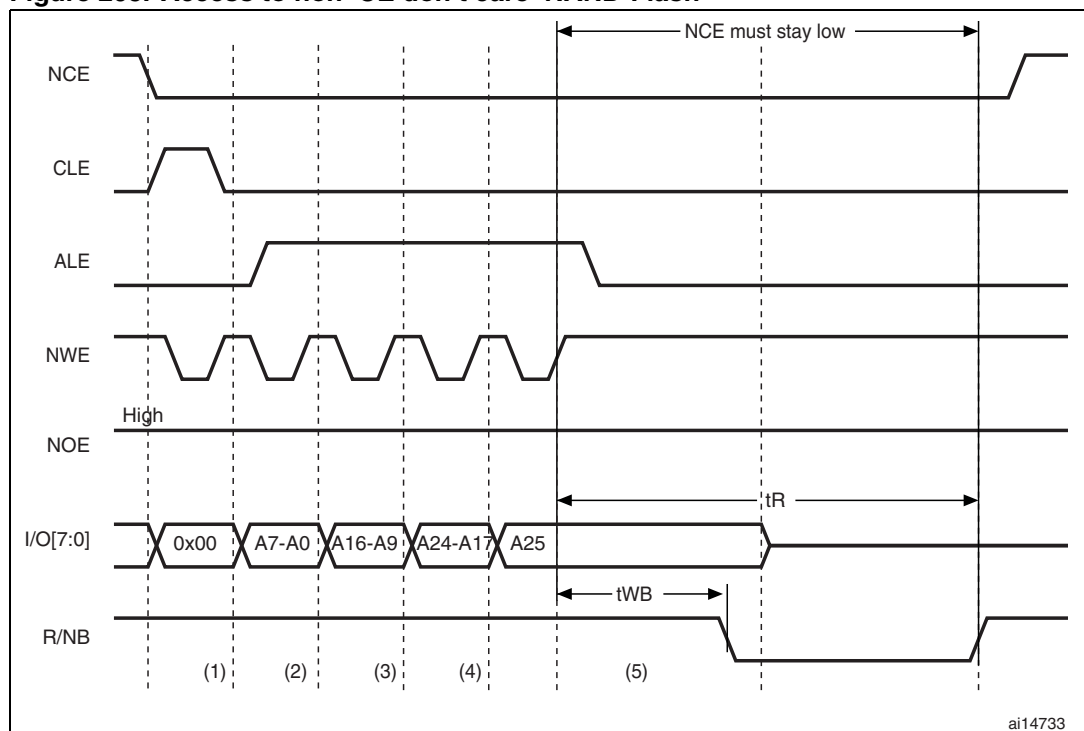
the start address for read operations. Using the attribute memory space makes it possible to use a different timing configuration of the FSMC, which can be used to implement the prewait functionality needed by some NAND Flash memories (see details in [Section 20.6.5: NAND Flash pre-wait functionality on page 512](#)).

4. The controller waits for the NAND Flash to be ready (R/NB signal high) to become active, before starting a new access (to same or another memory bank). While waiting, the controller maintains the NCE signal active (low).
5. The CPU can then perform byte read operations in the common memory space to read the NAND Flash page (data field + Spare field) byte by byte.
6. The next NAND Flash page can be read without any CPU command or address write operation, in three different ways:
  - by simply performing the operation described in step 5
  - a new random address can be accessed by restarting the operation at step 3
  - a new command can be sent to the NAND Flash device by restarting at step 2

### 20.6.5 NAND Flash pre-wait functionality

Some NAND Flash devices require that, after writing the last part of the address, the controller wait for the R/NB signal to go low as shown in [Figure 205](#).

**Figure 205. Access to non ‘CE don’t care’ NAND-Flash**



1. CPU wrote byte 0x00 at address 0x7001 0000.
2. CPU wrote byte A7~A0 at address 0x7002 0000.
3. CPU wrote byte A16~A9 at address 0x7002 0000.
4. CPU wrote byte A24~A17 at address 0x7002 0000.
5. CPU wrote byte A25 at address 0x7802 0000: FSMC performs a write access using FSMC\_PATT2 timing definition, where  $ATTHOLD \geq 7$  (providing that  $(7+1) \times HCLK = 112 \text{ ns} > t_{WB} \text{ max}$ ). This guarantees that NCE remains low until R/NB goes low and high again (only requested for NAND Flash memories where NCE is not don't care).



When this functionality is needed, it can be guaranteed by programming the MEMHOLD value to meet the  $t_{WB}$  timing, however any CPU read or write access to the NAND Flash then has the hold delay of (MEMHOLD + 1) HCLK cycles inserted from the rising edge of the NWE signal to the next access.

To overcome this timing constraint, the attribute memory space can be used by programming its timing register with an ATTHOLD value that meets the  $t_{WB}$  timing, and leaving the MEMHOLD value at its minimum. Then, the CPU must use the common memory space for all NAND Flash read and write accesses, except when writing the last address byte to the NAND Flash device, where the CPU must write to the attribute memory space.

### 20.6.6 Error correction code computation ECC (NAND Flash)

The FSMC PC-Card controller includes two error correction code computation hardware blocks, one per memory bank. They are used to reduce the host CPU workload when processing the error correction code by software in the system.

These two registers are identical and associated with bank 2 and bank 3, respectively. As a consequence, no hardware ECC computation is available for memories connected to bank 4.

The error correction code (ECC) algorithm implemented in the FSMC can perform 1-bit error correction and 2-bit error detection per 256, 512, 1 024, 2 048, 4 096 or 8 192 bytes read from or written to NAND Flash.

The ECC modules monitor the NAND Flash databus and read/write signals (NCE and NWE) each time the NAND Flash memory bank is active.

The functional operations are:

- When access to NAND Flash is made to bank 2 or bank 3, the data present on the D[15:0] bus is latched and used for ECC computation.
- When access to NAND Flash occurs at any other address, the ECC logic is idle, and does not perform any operation. Thus, write operations for defining commands or addresses to NAND Flash are not taken into account for ECC computation.

Once the desired number of bytes has been read from/written to the NAND Flash by the host CPU, the FSMC\_ECCR2/3 registers must be read in order to retrieve the computed value. Once read, they should be cleared by resetting the ECCEN bit to zero. To compute a new data block, the ECCEN bit must be set to one in the FSMC\_PCR2/3 registers.

### 20.6.7 PC Card/CompactFlash operations

#### Address spaces & memory accesses

The FSMC supports Compact Flash storage or PC Cards in Memory Mode and I/O Mode (True IDE mode is not supported).

The Compact Flash storage and PC Cards are made of 3 memory spaces :

- Common Memory Space
- Attribute Space
- I/O Memory Space

The nCE2 and nCE1 pins ( FSMC\_NCE4\_2 and FSMC\_NCE4\_1 respectively) select the card and indicate whether a byte or a word operation is being performed: nCE2 accesses

the odd byte on D15-8 and nCE1 accesses the even byte on D7-0 if A0=0 or the odd byte on D7-0 if A0=1. The full word is accessed on D15-0 if both nCE2 and nCE1 are low.

The memory space is selected by asserting low nOE for read accesses or nWE for write accesses, combined with the low assertion of nCE2/nCE1 and nREG.

- If pin nREG=1 during the memory access, the common memory space is selected
- If pin nREG=0 during the memory access, the attribute memory space is selected

The I/O Space is selected by asserting low nIORD for read accesses or nIOWR for write accesses [instead of nOE/nWE for memory Space], combined with nCE2/nCE1. Note that nREG must also be asserted low during accesses to I/O Space.

Three type of accesses are allowed for a 16-bit PC Card:

- Accesses to Common Memory Space for data storage can be either 8-bit accesses at even addresses or 16 bit AHB accesses.

Note that 8-bit accesses at odd addresses are not supported and will not lead to the low assertion of nCE2. A 32-bit AHB request is translated into two 16-bit memory accesses.

- Accesses to Attribute Memory Space where the PC Card stores configuration information are limited to 8-bit AHB accesses at even addresses.

Note that a 16-bit AHB access will be converted into a single 8-bit memory transfer: nCE1 will be asserted low, NCE2 will be asserted high and only the even Byte on D7-D0 will be valid. Instead a 32-bit AHB access will be converted into two 8-bit memory transfers at even addresses: nCE1 will be asserted low, NCE2 will be asserted high and only the even bytes will be valid.

- Accesses to I/O Space must be limited to AHB 16 bit accesses.

**Table 131. 16-bit PC-Card signals and access type**

nCE2	nCE1	nREG	nOE/nWE	nIORD /nIOWR	A10	A9	A7-1	A0	Space	Access Type	Allowed/not Allowed
1	0	1	0	1	X	X	X-X	X	Common Memory Space	Read/Write byte on D7-D0	YES
	YES									Read/Write byte on D15-D8	Not supported
0	1	1	0	1	X	X	X-X	X		Read/Write word on D15-D0	YES
0	0	1	0	1	X	X	X-X	0			
X	0	0	0	1	0	1	X-X	0	Attribute Space	Read or Write Configuration Registers	YES
X	0	0	0	1	0	0	X-X	0		Read or Write CIS (Card Information Structure)	YES
1	0	0	0	1	X	X	X-X	1	Invalid Attribute Space	Read or Write (odd address)	YES
0	1	0	0	1	X	X	X-X	x		Read or Write (odd address)	YES

**Table 131. 16-bit PC-Card signals and access type (continued)**

nCE2	nCE1	nREG	nOE/nWE	nIORD/nIOWR	A10	A9	A7-1	A0	Space	Access Type	Allowed/not Allowed
1	0	0	1	0	X	X	X-X	0	I/O space	Read Even Byte on D7-0	Not supported
1	0	0	1	0	X	X	X-X	1		Read Odd Byte on D7-0	Not supported
1	0	0	1	0	X	X	X-X	0		Write Even Byte on D7-0	Not supported
1	0	0	1	0	X	X	X-X	1		Write Odd Byte on D7-0	Not supported
0	0	0	1	0	X	X	X-X	0		Read Word on D15-0	YES
0	0	0	1	0	X	X	X-X	0		Write word on D15-0	YES
0	1	0	1	0	X	X	X-X	X		Read Odd Byte on D15-8	Not supported
0	1	0	1	0	X	X	X-X	X		Write Odd Byte on D15-8	Not supported

The FSMC Bank 4 gives access to those 3 memory spaces as described in [Section 20.4.2: NAND/PC Card address mapping - Table 99: Memory mapping and timing registers](#)

**Wait Feature**

The CompactFlash Storage or PC Card may request the FSMC to extend the length of the access phase programmed by MEMWAITx/ATTWAITx/IOWAITx bits, asserting the nWAIT signal after nOE/nWE or nIORD/nIOWR activation if the wait feature is enabled through the PWAITEN bit in the FSMC\_PCRx register. In order to detect the nWAIT assertion correctly, the MEMWAITx/ATTWAITx/IOWAITx bits must be programmed as follows:

$$xxWAITx \geq 4 + \text{max\_wait\_assertion\_time}/HCLK$$

Where max\_wait\_assertion\_time is the maximum time taken by nWAIT to go low once nOE/nWE or nIORD/nIOWR is low.

After the de-assertion of nWAIT, the FSMC extends the WAIT phase for 4 HCLK clock cycles.

### 20.6.8 NAND Flash/PC Card controller registers

The peripheral registers have to be accessed by words (32-bit).

#### PC Card/NAND Flash control registers 2..4 (FSMC\_PCR2..4)

Address offset:  $0xA0000000 + 0x40 + 0x20 * (x - 1)$ ,  $x = 2..4$

Reset value: 0x0000 0018

31	30	29	28	27	26	25	24	23	22	21	20	19	18	17	16	15	14	13	12	11	10	9	8	7	6	5	4	3	2	1	0													
Reserved												ECCPS				TAR				TCLR				Res.		ECCEN	PWID		PTYP	PBKEN	PWAITEN	Reserved												
												rw	rw	rw	rw	rw	rw	rw	rw	rw	rw	rw	rw	rw	rw	rw	rw	rw	rw	rw	rw	rw	rw	rw	rw	rw	rw	rw	rw	rw	rw	rw	rw	rw

Bits 19:17 **ECCPS**: ECC page size.

Defines the page size for the extended ECC:

000: 256 bytes

001: 512 bytes

010: 1024 bytes

011: 2048 bytes

100: 4096 bytes

101: 8192 bytes

Bits 16:13 **TAR**: ALE to RE delay.

Sets time from ALE low to RE low in number of AHB clock cycles (HCLK).

Time is:  $t_{ar} = (TAR + SET + 4) \times THCLK$  where THCLK is the HCLK clock period

0000: 1 HCLK cycle (default)

1111: 16 HCLK cycles

*Note: SET is MEMSET or ATTSET according to the addressed space.*

Bits 12:9 **TCLR**: CLE to RE delay.

Sets time from CLE low to RE low in number of AHB clock cycles (HCLK).

Time is:  $t_{clr} = (TCLR + SET + 4) \times THCLK$  where THCLK is the HCLK clock period

0000: 1 HCLK cycle (default)

1111: 16 HCLK cycles

*Note: SET is MEMSET or ATTSET according to the addressed space.*

Bits 8:7 Reserved.

Bits 6 **ECCEN**: ECC computation logic enable bit

0: ECC logic is disabled and reset (default after reset),

1: ECC logic is enabled.

Bits 5:4 **PWID**: Databus width.

Defines the external memory device width.

00: 8 bits (default after reset)

01: 16 bits (mandatory for PC Card)

10: reserved, do not use

11: reserved, do not use

Bit 3 **PTYP**: Memory type.

Defines the type of device attached to the corresponding memory bank:

0: PC Card, CompactFlash, CF+ or PCMCIA

1: NAND Flash (default after reset)

- Bit 2 **PBKEN**: PC Card/NAND Flash memory bank enable bit.  
 Enables the memory bank. Accessing a disabled memory bank causes an ERROR on AHB bus  
 0: Corresponding memory bank is disabled (default after reset)  
 1: Corresponding memory bank is enabled
- Bit 1 **PWAITEN**: Wait feature enable bit.  
 Enables the Wait feature for the PC Card/NAND Flash memory bank:  
 0: disabled  
 1: enabled  
*Note: For a PC Card, when the wait feature is enabled, the MEMWAITx/ATTWAITx/IOWAITx bits must be programmed to a value as follows:*  
 $xxWAITx \geq 4 + \frac{max\_wait\_assertion\_time}{HCLK}$   
*Where max\_wait\_assertion\_time is the maximum time taken by NWAIT to go low once nOE/nWE or nLORD/nLOWR is low.*
- Bit 0 Reserved.

**FIFO status and interrupt register 2..4 (FSMC\_SR2..4)**

Address offset: 0xA000 0000 + 0x44 + 0x20 \* (x-1), x = 2..4

Reset value: 0x0000 0040

This register contains information about FIFO status and interrupt. The FSMC has a FIFO that is used when writing to memories to store up to 16 words of data from the AHB. This is used to quickly write to the AHB and free it for transactions to peripherals other than the FSMC, while the FSMC is draining its FIFO into the memory. This register has one of its bits that indicates the status of the FIFO, for ECC purposes. The ECC is calculated while the data are written to the memory, so in order to read the correct ECC the software must wait until the FIFO is empty.

31	30	29	28	27	26	25	24	23	22	21	20	19	18	17	16	15	14	13	12	11	10	9	8	7	6	5	4	3	2	1	0
Reserved													FEMPT	IFEN	ILEN	IREN	IFS	ILS	IRS												
													r	rw	rw	rw	rw	rw	rw												

- Bit 6 **FEMPT**: FIFO empty.  
 Read-only bit that provides the status of the FIFO  
 0: FIFO not empty  
 1: FIFO empty
- Bit 5 **IFEN**: Interrupt falling edge detection enable bit  
 0: Interrupt falling edge detection request disabled  
 1: Interrupt falling edge detection request enabled
- Bit 4 **ILEN**: Interrupt high-level detection enable bit  
 0: Interrupt high-level detection request disabled  
 1: Interrupt high-level detection request enabled
- Bit 3 **IREN**: Interrupt rising edge detection enable bit  
 0: Interrupt rising edge detection request disabled  
 1: Interrupt rising edge detection request enabled

- Bit 2 **IFS**: Interrupt falling edge status  
 The flag is set by hardware and reset by software.  
 0: No interrupt falling edge occurred  
 1: Interrupt falling edge occurred
- Bit 1 **ILS**: Interrupt high-level status  
 The flag is set by hardware and reset by software.  
 0: No Interrupt high-level occurred  
 1: Interrupt high-level occurred
- Bit 0 **IRS**: Interrupt rising edge status  
 The flag is set by hardware and reset by software.  
 0: No interrupt rising edge occurred  
 1: Interrupt rising edge occurred

**Common memory space timing register 2..4 (FSMC\_PMEM2..4)**

Address offset: Address: 0xA000 0000 + 0x48 + 0x20 \* (x - 1), x = 2..4

Reset value: 0xFCFC FCFC

Each FSMC\_PMEMx (x = 2..4) read/write register contains the timing information for PC Card or NAND Flash memory bank x, used for access to the common memory space of the 16-bit PC Card/CompactFlash, or to access the NAND Flash for command, address write access and data read/write access.

31	30	29	28	27	26	25	24	23	22	21	20	19	18	17	16	15	14	13	12	11	10	9	8	7	6	5	4	3	2	1	0
MEMHIZx								MEMHOLDx								MEMWAITx								MEMSETx							
rw	rw	rw	rw	rw	rw	rw	rw	rw	rw	rw	rw	rw	rw	rw	rw	rw	rw	rw	rw	rw	rw	rw	rw	rw	rw	rw	rw	rw	rw	rw	rw

- Bits 31:24 **MEMHIZx**: Common memory x databus HiZ time  
 Defines the number of HCLK (+1 only for NAND) clock cycles during which the databus is kept in HiZ after the start of a PC Card/NAND Flash write access to common memory space on socket x. Only valid for write transaction:  
 0000 0000: (0x00) 0 HCLK cycle (for PC Card) / 1 HCLK cycle (for NAND Flash)  
 1111 1111: (0xFF) 255 HCLK cycles (for PC Card) / 256 HCLK cycles (for NAND Flash) - (default value after reset)
- Bits 23:16 **MEMHOLDx**: Common memory x hold time  
 Defines the number of HCLK clock cycles to hold address (and data for write access) after the command deassertion (NWE, NOE), for PC Card/NAND Flash read or write access to common memory space on socket x:  
 0000 0000: reserved  
 0000 0001: 1 HCLK cycle  
 1111 1111: 255 HCLK cycles (default value after reset)
- Bits 15:8 **MEMWAITx**: Common memory x wait time  
 Defines the minimum number of HCLK (+1) clock cycles to assert the command (NWE, NOE), for PC Card/NAND Flash read or write access to common memory space on socket x. The duration for command assertion is extended if the wait signal (NWAIT) is active (low) at the end of the programmed value of HCLK:  
 0000 0000: reserved  
 0000 0001: 2HCLK cycles (+ wait cycle introduced by deasserting NWAIT)  
 1111 1111: 256 HCLK cycles (+ wait cycle introduced by the Card deasserting NWAIT) (default value after reset)



Bits 7:0 **MEMSETx**: Common memory x setup time

Defines the number of HCLK (+1 for PC Card, +2 for NAND) clock cycles to set up the address before the command assertion (NWE, NOE), for PC Card/NAND Flash read or write access to common memory space on socket x:

0000 0000: 1 HCLK cycle (for PC Card) / HCLK cycles (for NAND Flash)

1111 1111: 256 HCLK cycles (for PC Card) / 257 HCLK cycles (for NAND Flash) - (default value after reset)

### Attribute memory space timing registers 2..4 (FSMC\_PATT2..4)

Address offset:  $0xA000\ 0000 + 0x4C + 0x20 * (x - 1)$ ,  $x = 2..4$

Reset value: 0xFCFC FCFC

Each FSMC\_PATTx ( $x = 2..4$ ) read/write register contains the timing information for PC Card/CompactFlash or NAND Flash memory bank x. It is used for 8-bit accesses to the attribute memory space of the PC Card/CompactFlash or to access the NAND Flash for the last address write access if the timing must differ from that of previous accesses (for Ready/Busy management, refer to [Section 20.6.5: NAND Flash pre-wait functionality](#)).

31	30	29	28	27	26	25	24	23	22	21	20	19	18	17	16	15	14	13	12	11	10	9	8	7	6	5	4	3	2	1	0	
ATTHIZx								ATTHOLDx								ATTWAITx								ATTSETx								
rW	rW	rW	rW	rW	rW	rW	rW	rW	rW	rW	rW	rW	rW	rW	rW	rW	rW	rW	rW	rW	rW	rW	rW	rW	rW	rW	rW	rW	rW	rW	rW	rW

Bits 31:24 **ATTHIZx**: Attribute memory x databus HiZ time

Defines the number of HCLK clock cycles during which the databus is kept in HiZ after the start of a PC CARD/NAND Flash write access to attribute memory space on socket x. Only valid for write transaction:

0000 0000: 0 HCLK cycle

1111 1111: 255 HCLK cycles (default value after reset)

Bits 23:16 **ATTHOLDx**: Attribute memory x hold time

Defines the number of HCLK clock cycles to hold address (and data for write access) after the command deassertion (NWE, NOE), for PC Card/NAND Flash read or write access to attribute memory space on socket x

0000 0000: reserved

0000 0001: 1 HCLK cycle

1111 1111: 255 HCLK cycles (default value after reset)

Bits 15:8 **ATTWAITx**: Attribute memory x wait time

Defines the minimum number of HCLK (+1) clock cycles to assert the command (NWE, NOE), for PC Card/NAND Flash read or write access to attribute memory space on socket x. The duration for command assertion is extended if the wait signal (NWAIT) is active (low) at the end of the programmed value of HCLK:

0000 0000: reserved

0000 0001: 2 HCLK cycles (+ wait cycle introduced by deassertion of NWAIT)

1111 1111: 256 HCLK cycles (+ wait cycle introduced by the card deasserting NWAIT) (default value after reset)

Bits 7:0 **ATTSETx**: Attribute memory x setup time

Defines the number of HCLK (+1) clock cycles to set up address before the command assertion (NWE, NOE), for PC CARD/NAND Flash read or write access to attribute memory space on socket x:

0000 0000: 1 HCLK cycle

1111 1111: 256 HCLK cycles (default value after reset)

**I/O space timing register 4 (FSMC\_PIO4)**

Address offset: 0xA000 0000 + 0xB0

Reset value: 0xFCFCFCFC

The FSMC\_PIO4 read/write registers contain the timing information used to gain access to the I/O space of the 16-bit PC Card/CompactFlash.

31	30	29	28	27	26	25	24	23	22	21	20	19	18	17	16	15	14	13	12	11	10	9	8	7	6	5	4	3	2	1	0
IOHIZx								IOHOLDx								IOWAITx								IOSETx							
rw	rw	rw	rw	rw	rw	rw	rw	rw	rw	rw	rw	rw	rw	rw	rw	rw	rw	rw	rw	rw	rw	rw	rw	rw	rw	rw	rw	rw	rw	rw	rw

Bits 31:24 **IOHIZx**: I/O x databus HiZ time

Defines the number of HCLK clock cycles during which the databus is kept in HiZ after the start of a PC Card write access to I/O space on socket x. Only valid for write transaction:

0000 0000: 0 HCLK cycle

1111 1111: 255 HCLK cycles (default value after reset)

Bits 23:16 **IOHOLDx**: I/O x hold time

Defines the number of HCLK clock cycles to hold address (and data for write access) after the command deassertion (NWE, NOE), for PC Card read or write access to I/O space on socket x:

0000 0000: reserved

0000 0001: 1 HCLK cycle

1111 1111: 255 HCLK cycles (default value after reset)

Bits 15:8 **IOWAITx**: I/O x wait time

Defines the minimum number of HCLK (+1) clock cycles to assert the command (SMNWE, SMNOE), for PC Card read or write access to I/O space on socket x. The duration for command assertion is extended if the wait signal (NWAIT) is active (low) at the end of the programmed value of HCLK:

0000 0000: reserved, do not use this value

0000 0001: 2 HCLK cycles (+ wait cycle introduced by deassertion of NWAIT)

1111 1111: 256 HCLK cycles (+ wait cycle introduced by the Card deasserting NWAIT) (default value after reset)

Bits 7:0 **IOSETx**: I/O x setup time

Defines the number of HCLK (+1) clock cycles to set up the address before the command assertion (NWE, NOE), for PC Card read or write access to I/O space on socket x:

0000 0000: 1 HCLK cycle

1111 1111: 256 HCLK cycles (default value after reset)

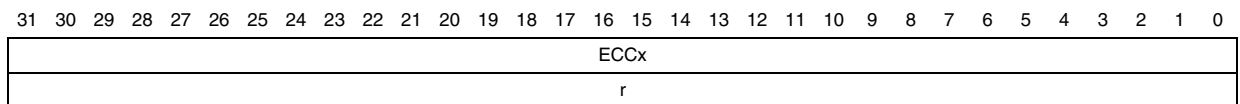


**ECC result registers 2/3 (FSMC\_ECCR2/3)**

Address offset:  $0xA000\ 0000 + 0x54 + 0x20 * (x - 1)$ ,  $x = 2$  or  $3$

Reset value:  $0x0000\ 0000$

These registers contain the current error correction code value computed by the ECC computation modules of the FSMC controller (one module per NAND Flash memory bank). When the CPU reads the data from a NAND Flash memory page at the correct address (refer to [Section 20.6.6: Error correction code computation ECC \(NAND Flash\)](#)), the data read from or written to the NAND Flash are processed automatically by ECC computation module. At the end of X bytes read (according to the ECCPS field in the FSMC\_PCRx registers), the CPU must read the computed ECC value from the FSMC\_ECCx registers, and then verify whether these computed parity data are the same as the parity value recorded in the spare area, to determine whether a page is valid, and, to correct it if applicable. The FSMC\_ECCRx registers should be cleared after being read by setting the ECCEN bit to zero. For computing a new data block, the ECCEN bit must be set to one.



Bits 31:0 **ECCx**: ECC result

This field provides the value computed by the ECC computation logic. [Table 132](#) hereafter describes the contents of these bit fields.

**Table 132. ECC result relevant bits**

ECCPS[2:0]	Page size in bytes	ECC bits
000	256	ECC[21:0]
001	512	ECC[23:0]
010	1024	ECC[25:0]
011	2048	ECC[27:0]
100	4096	ECC[29:0]
101	8192	ECC[31:0]

### 20.6.9 FSMC register map

The following table summarizes the FSMC registers.

**Table 133. FSMC register map**

Offset	Register	31	30	29	28	27	26	25	24	23	22	21	20	19	18	17	16	15	14	13	12	11	10	9	8	7	6	5	4	3	2	1	0
0xA000 0000	FSMC_BCR1	Reserved												CBURSTRW	Reserved				ASYNCSWAIT	EXTMOD	WAITEN	WREN	WAITCFG		WAITPOL	BURSTEN	Reserved	FACCEN	MWID		MTYP	MUXEN	MBKEN
	Reset value																																
0xA000 0008	FSMC_BCR2	Reserved												CBURSTRW	Reserved				ASYNCSWAIT	EXTMOD	WAITEN	WREN	WAITCFG	WRAPMOD	WAITPOL	BURSTEN	Reserved	FACCEN	MWID		MTYP	MUXEN	MBKEN
	Reset value																																
0xA000 0010	FSMC_BCR3	Reserved												CBURSTRW	Reserved				ASYNCSWAIT	EXTMOD	WAITEN	WREN	WAITCFG	WRAPMOD	WAITPOL	BURSTEN	Reserved	FACCEN	MWID		MTYP	MUXEN	MBKEN
	Reset value																																
0xA000 0018	FSMC_BCR4	Reserved												CBURSTRW	Reserved				ASYNCSWAIT	EXTMOD	WAITEN	WREN	WAITCFG	WRAPMOD	WAITPOL	BURSTEN	Reserved	FACCEN	MWID		MTYP	MUXEN	MBKEN
	Reset value																																
0xA000 0004	FSMC_BTR1	Res.	ACCM OD	DATLAT	CLKDIV	BUSTURN			DATAST				ADDHLD		ADDSET																		
0xA000 000C	FSMC_BTR2	Res.	ACCM OD	DATLAT	CLKDIV	BUSTURN			DATAST				ADDHLD		ADDSET																		
0xA000 0014	FSMC_BTR3	Res.	ACCM OD	DATLAT	CLKDIV	BUSTURN			DATAST				ADDHLD		ADDSET																		
0xA000 001C	FSMC_BTR4	Res.	ACCM OD	DATLAT	CLKDIV	BUSTURN			DATAST				ADDHLD		ADDSET																		
0xA000 0104	FSMC_BWTR1	Res.	ACCM OD	DATLAT	CLKDIV	Reserved			DATAST				ADDHLD		ADDSET																		
0xA000 010C	FSMC_BWTR2	Res.	ACCM OD	DATLAT	CLKDIV	Reserved			DATAST				ADDHLD		ADDSET																		
0xA000 0114	FSMC_BWTR3	Res.	ACCM OD	DATLAT	CLKDIV	Reserved			DATAST				ADDHLD		ADDSET																		
0xA000 011C	FSMC_BWTR4	Res.	ACCM OD	DATLAT	CLKDIV	Reserved			DATAST				ADDHLD		ADDSET																		
0xA000 0060	FSMC_PCR2	Reserved												ECCPS	TAR		TCLR		Res.	ECCEN	PWID	PTYP	PBKEN	PWAITEN	Reserved								
	Reset value																																
0xA000 0080	FSMC_PCR3	Reserved												ECCPS	TAR		TCLR		Res.	ECCEN	PWID	PTYP	PBKEN	PWAITEN	Reserved								
	Reset value																																
0xA000 00A0	FSMC_PCR4	Reserved												ECCPS	TAR		TCLR		Res.	ECCEN	PWID	PTYP	PBKEN	PWAITEN	Reserved								
	Reset value																																
0xA000 0064	FSMC_SR2	Reserved												FEMPT		IFEN	ILEN	IREN	IFS	ILS	IRS												
	Reset value																																
0xA000 0084	FSMC_SR3	Reserved												FEMPT		IFEN	ILEN	IREN	IFS	ILS	IRS												
	Reset value																																
0xA000 00A4	FSMC_SR4	Reserved												FEMPT		IFEN	ILEN	IREN	IFS	ILS	IRS												
	Reset value																																
0xA000 0068	FSMC_PMEM2	MEMHIZx				MEMHOLDx				MEMWAITx				MEMSETx																			
0xA000 0088	FSMC_PMEM3	MEMHIZx				MEMHOLDx				MEMWAITx				MEMSETx																			



**Table 133. FSMC register map (continued)**

Offset	Register	31	30	29	28	27	26	25	24	23	22	21	20	19	18	17	16	15	14	13	12	11	10	9	8	7	6	5	4	3	2	1	0
0xA000 00A8	FSMC_PMEM4	MEMHIZx				MEMHOLDx				MEMWAITx				MEMSETx																			
0xA000 006C	FSMC_PATT2	ATTHIZx				ATTHOLDx				ATTWAITx				ATTSETx																			
0xA000 008C	FSMC_PATT3	ATTHIZx				ATTHOLDx				ATTWAITx				ATTSETx																			
0xA000 00AC	FSMC_PATT4	ATTHIZx				ATTHOLDx				ATTWAITx				ATTSETx																			
0xA000 00B0	FSMC_PIO4	IOHIZx				IOHOLDx				IOWAITx				IOSETx																			
0xA000 0074	FSMC_ECCR2	ECCx																															
0xA000 0094	FSMC_ECCR3	ECCx																															

Note: Refer to [Table 1 on page 44](#) for the register boundary addresses.

## 21 Secure digital input/output interface (SDIO)

**Low-density devices** are STM32F101xx, STM32F102xx and STM32F103xx microcontrollers where the Flash memory density ranges between 16 and 32 Kbytes.

**Medium-density devices** are STM32F101xx, STM32F102xx and STM32F103xx microcontrollers where the Flash memory density ranges between 64 and 128 Kbytes.

**High-density devices** are STM32F101xx and STM32F103xx microcontrollers where the Flash memory density ranges between 256 and 512 Kbytes.

**XL-density devices** are STM32F101xx and STM32F103xx microcontrollers where the Flash memory density ranges between 768 Kbytes and 1 Mbyte.

**Connectivity line devices** are STM32F105xx and STM32F107xx microcontrollers.

This section applies to high-density and XL-density performance line devices only.

### 21.1 SDIO main features

The SD/SDIO MMC card host interface (SDIO) provides an interface between the AHB peripheral bus and MultiMediaCards (MMCs), SD memory cards, SDIO cards and CE-ATA devices.

The MultiMediaCard system specifications are available through the MultiMediaCard Association website at [www.mmca.org](http://www.mmca.org), published by the MMCA technical committee.

SD memory card and SD I/O card system specifications are available through the SD card Association website at [www.sdcard.org](http://www.sdcard.org).

CE-ATA system specifications are available through the CE-ATA workgroup website at [www.ce-ata.org](http://www.ce-ata.org).

The SDIO features include the following:

- Full compliance with *MultiMediaCard System Specification Version 4.2*. Card support for three different databus modes: 1-bit (default), 4-bit and 8-bit
- Full compatibility with previous versions of MultiMediaCards (forward compatibility)
- Full compliance with *SD Memory Card Specifications Version 2.0*
- Full compliance with *SD I/O Card Specification Version 2.0*: card support for two different databus modes: 1-bit (default) and 4-bit
- Full support of the CE-ATA features (full compliance with *CE-ATA digital protocol Rev1.1*)
- Data transfer up to 48 MHz for the 8 bit mode
- Data and command output enable signals to control external bidirectional drivers.

*Note:* 1 The SDIO does not have an SPI-compatible communication mode.

2 The SD memory card protocol is a superset of the MultiMediaCard protocol as defined in the MultiMediaCard system specification V2.11. Several commands required for SD memory devices are not supported by either SD I/O-only cards or the I/O portion of combo cards. Some of these commands have no use in SD I/O devices, such as erase commands, and thus are not supported in the SDIO. In addition, several commands are different between SD memory cards and SD I/O cards and thus are not supported in the SDIO. For details refer to SD I/O card Specification Version 1.0. CE-ATA is supported over the MMC electrical

interface using a protocol that utilizes the existing MMC access primitives. The interface electrical and signaling definition is as defined in the MMC reference.

The MultiMediaCard/SD bus connects cards to the controller.

The current version of the SDIO supports only one SD/SDIO/MMC4.2 card at any one time and a stack of MMC4.1 or previous.

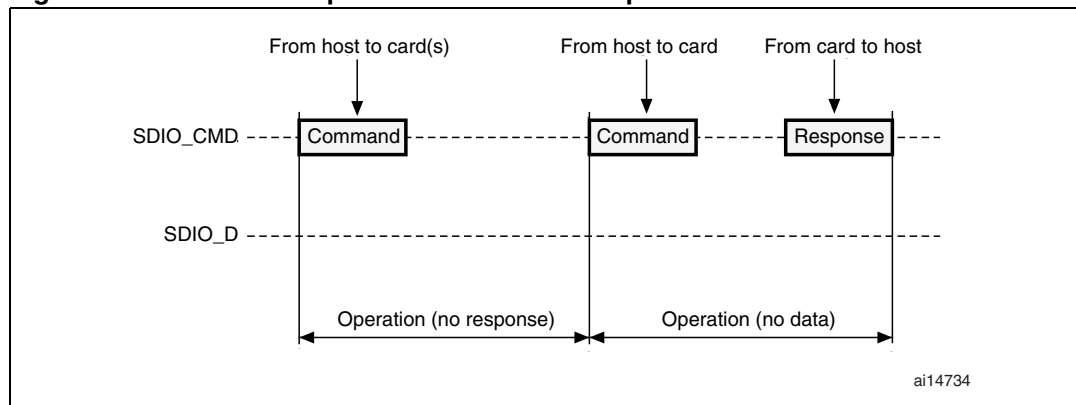
## 21.2 SDIO bus topology

Communication over the bus is based on command and data transfers.

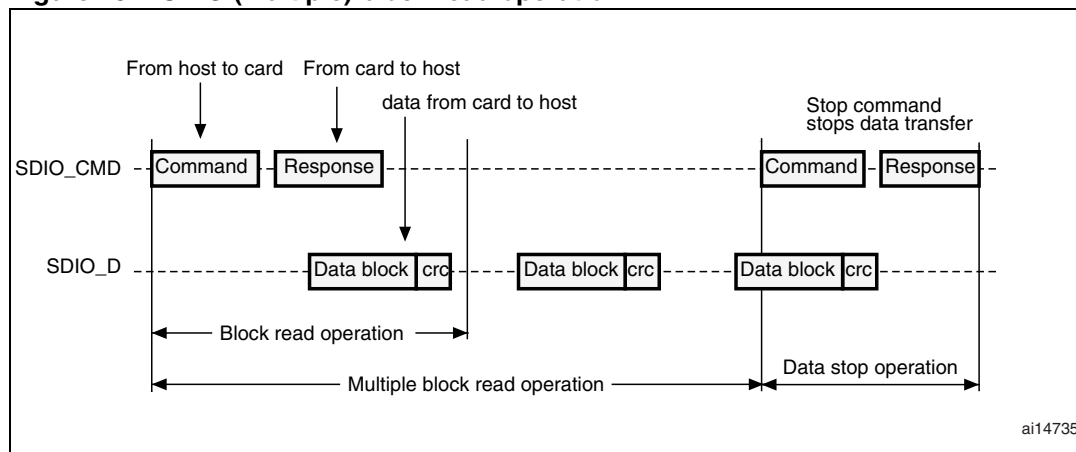
The basic transaction on the MultiMediaCard/SD/SD I/O bus is the command/response transaction. These types of bus transaction transfer their information directly within the command or response structure. In addition, some operations have a data token.

Data transfers to/from SD/SDIO memory cards are done in data blocks. Data transfers to/from MMC are done data blocks or streams. Data transfers to/from the CE-ATA Devices are done in data blocks.

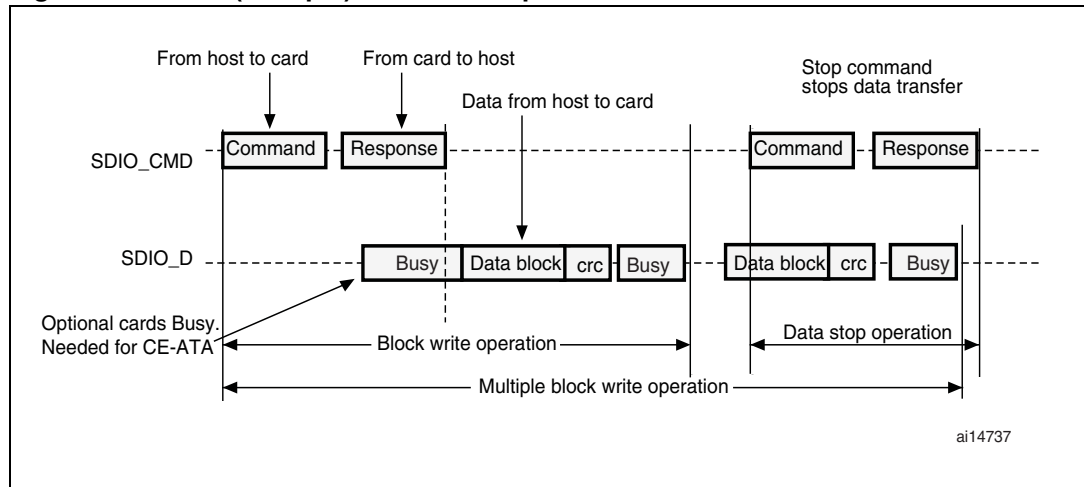
**Figure 206. SDIO “no response” and “no data” operations**



**Figure 207. SDIO (multiple) block read operation**

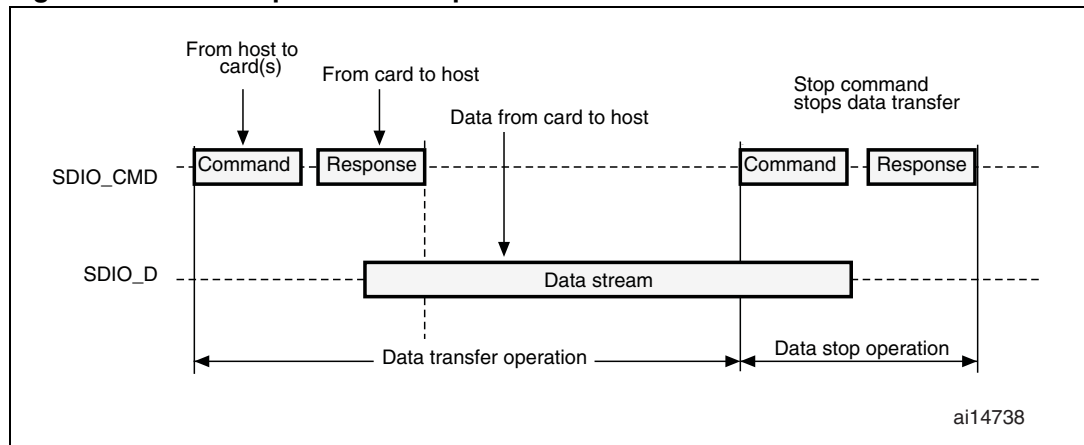


**Figure 208. SDIO (multiple) block write operation**

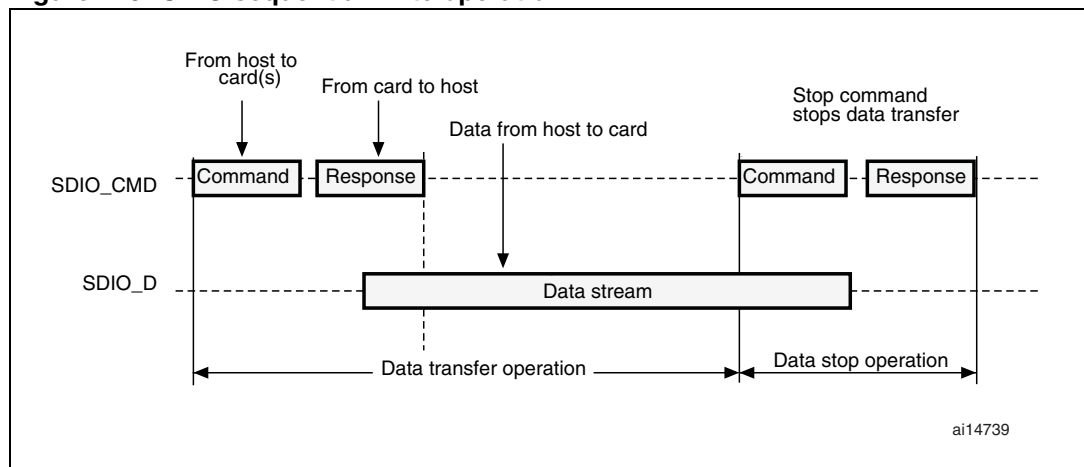


*Note:* The SDIO will not send any data as long as the Busy signal is asserted (SDIO\_D0 pulled low).

**Figure 209. SDIO sequential read operation**



**Figure 210. SDIO sequential write operation**

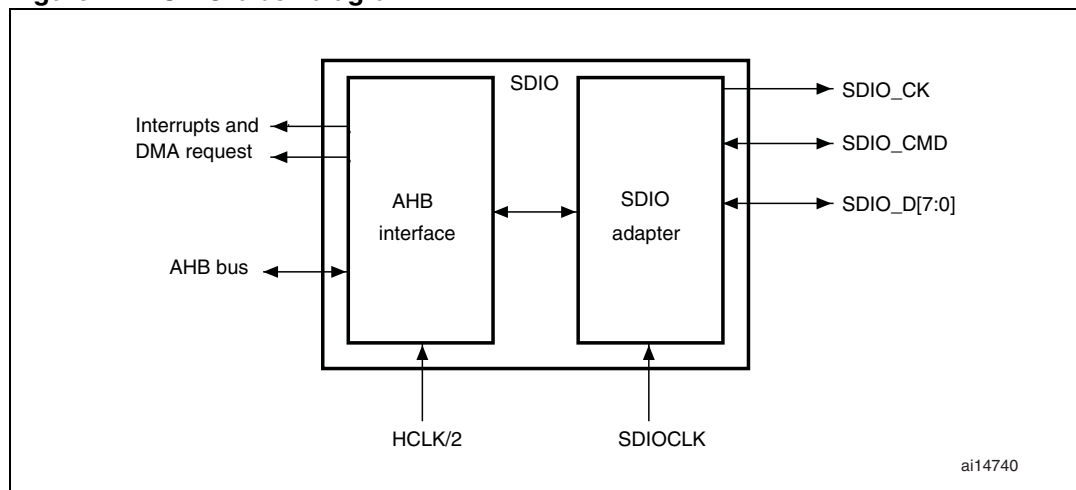


## 21.3 SDIO functional description

The SDIO consists of two parts:

- The SDIO adapter block provides all functions specific to the MMC/SD/SD I/O card such as the clock generation unit, command and data transfer.
- The AHB interface accesses the SDIO adapter registers, and generates interrupt and DMA request signals.

**Figure 211. SDIO block diagram**



By default SDIO\_D0 is used for data transfer. After initialization, the host can change the databus width.

If a MultiMediaCard is connected to the bus, SDIO\_D0, SDIO\_D[3:0] or SDIO\_D[7:0] can be used for data transfer. MMC V3.31 or previous, supports only 1 bit of data so only SDIO\_D0 can be used.

If an SD or SD I/O card is connected to the bus, data transfer can be configured by the host to use SDIO\_D0 or SDIO\_D[3:0]. All data lines are operating in push-pull mode.

**SDIO\_CMD** has two operational modes:

- Open-drain for initialization (only for MMCV3.31 or previous)
- Push-pull for command transfer (SD/SD I/O card MMC4.2 use push-pull drivers also for initialization)

**SDIO\_CK** is the clock to the card: one bit is transferred on both command and data lines with each clock cycle. The clock frequency can vary between 0 MHz and 20 MHz (for a MultiMediaCard V3.31), between 0 and 48 MHz for a MultiMediaCard V4.0/4.2, or between 0 and 25 MHz (for an SD/SD I/O card).

The SDIO uses two clock signals:

- SDIO adapter clock (SDIOCLK = HCLK)
- AHB bus clock (HCLK/2)

The signals shown in [Table 134](#) are used on the MultiMediaCard/SD/SD I/O card bus.

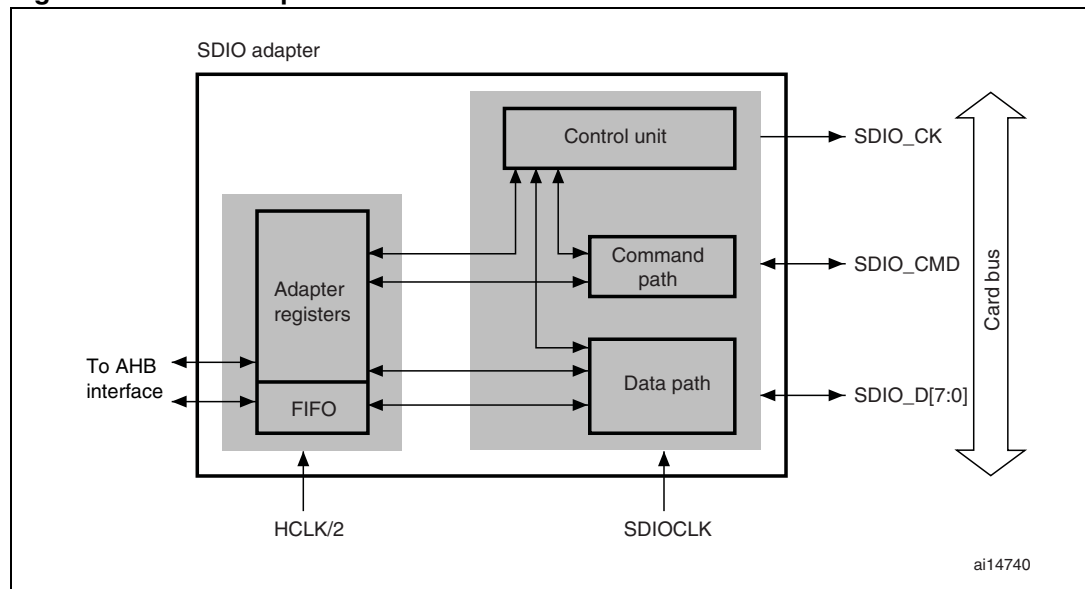
Table 134. SDIO I/O definitions

Pin	Direction	Description
SDIO_CK	Output	MultiMediaCard/SD/SDIO card clock. This pin is the clock from host to card.
SDIO_CMD	Bidirectional	MultiMediaCard/SD/SDIO card command. This pin is the bidirectional command/response signal.
SDIO_D[7:0]	Bidirectional	MultiMediaCard/SD/SDIO card data. These pins are the bidirectional databus.

### 21.3.1 SDIO adapter

Figure 212 shows a simplified block diagram of an SDIO adapter.

Figure 212. SDIO adapter



The SDIO adapter is a multimedia/secure digital memory card bus master that provides an interface to a multimedia card stack or to a secure digital memory card. It consists of five subunits:

- Adapter register block
- Control unit
- Command path
- Data path
- Data FIFO

*Note:* The adapter registers and FIFO use the AHB bus clock domain (HCLK/2). The control unit, command path and data path use the SDIO adapter clock domain (SDIOCLK).

#### Adapter register block

The adapter register block contains all system registers. This block also generates the signals that clear the static flags in the multimedia card. The clear signals are generated when 1 is written into the corresponding bit location in the SDIO Clear register.



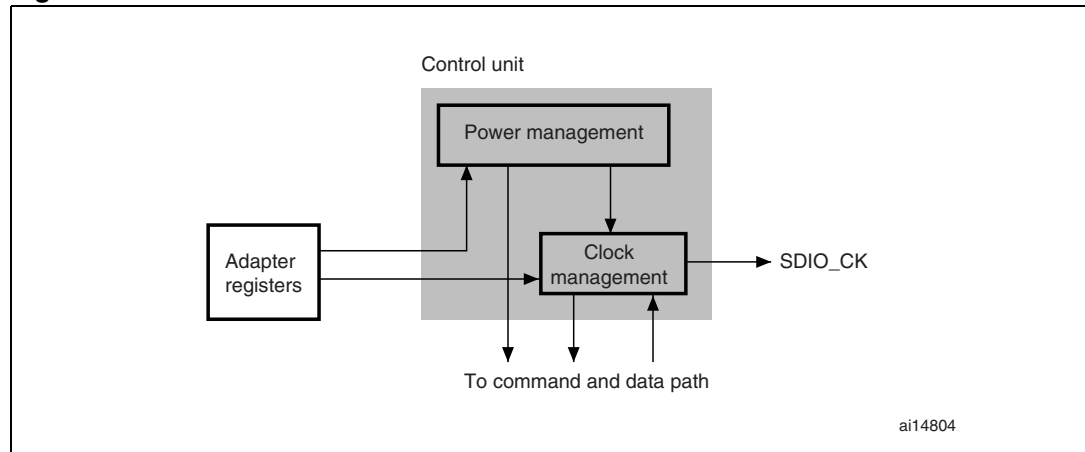
## Control unit

The control unit contains the power management functions and the clock divider for the memory card clock.

There are three power phases:

- power-off
- power-up
- power-on

**Figure 213. Control unit**



The control unit is illustrated in [Figure 213](#). It consists of a power management subunit and a clock management subunit.

The power management subunit disables the card bus output signals during the power-off and power-up phases.

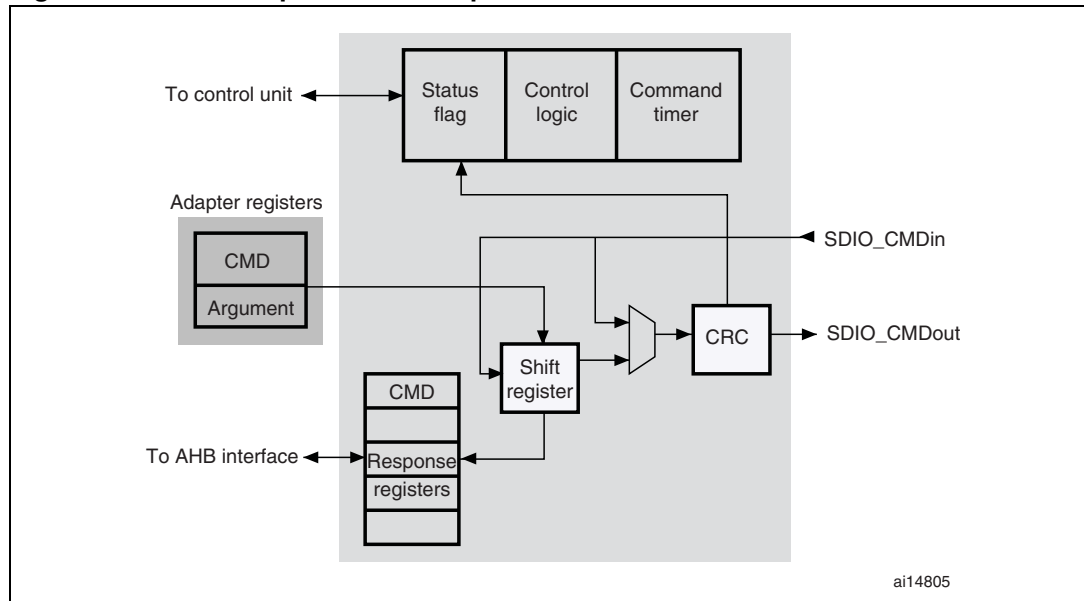
The clock management subunit generates and controls the SDIO\_CK signal. The SDIO\_CK output can use either the clock divide or the clock bypass mode. The clock output is inactive:

- after reset
- during the power-off or power-up phases
- if the power saving mode is enabled and the card bus is in the Idle state (eight clock periods after both the command and data path subunits enter the Idle phase)

## Command path

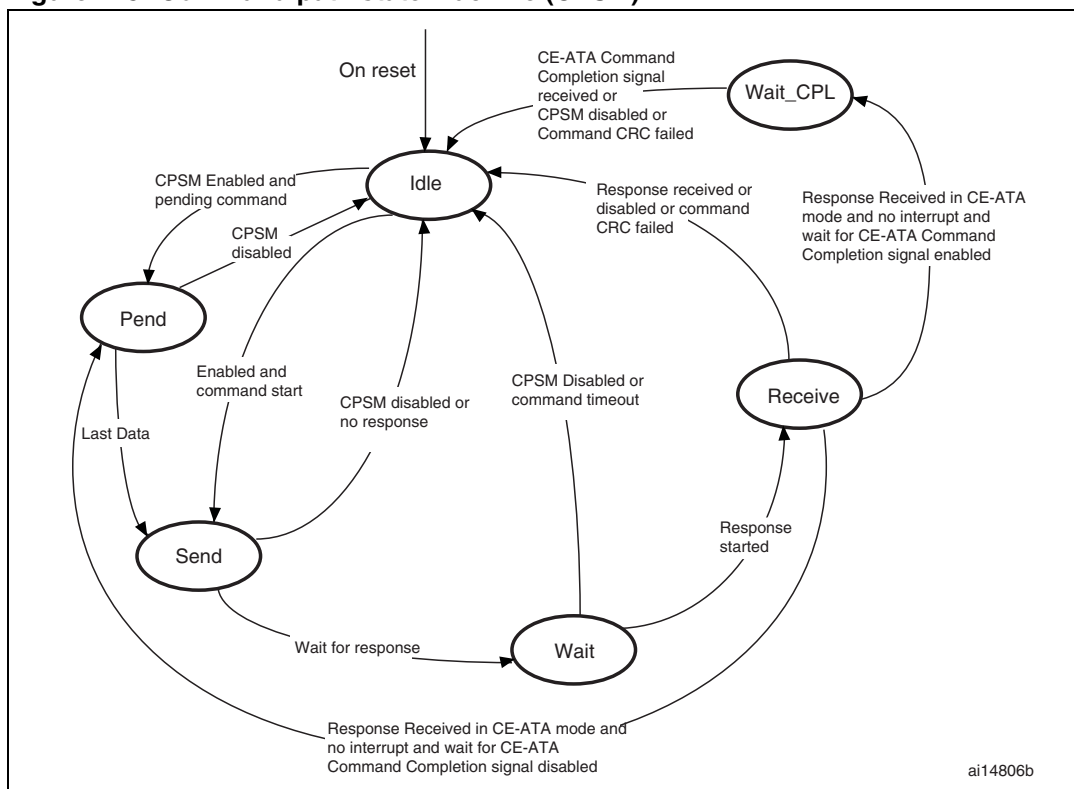
The command path unit sends commands to and receives responses from the cards.

Figure 214. SDIO adapter command path



- Command path state machine (CPSM)
  - When the command register is written to and the enable bit is set, command transfer starts. When the command has been sent, the command path state machine (CPSM) sets the status flags and enters the Idle state if a response is not required. If a response is required, it waits for the response (see [Figure 215 on page 531](#)). When the response is received, the received CRC code and the internally generated code are compared, and the appropriate status flags are set.

Figure 215. Command path state machine (CPSM)



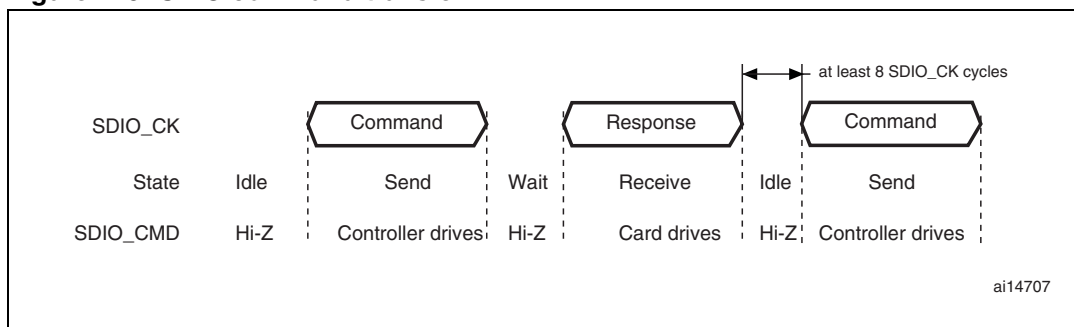
When the Wait state is entered, the command timer starts running. If the timeout is reached before the CPSM moves to the Receive state, the timeout flag is set and the Idle state is entered.

*Note:* The command timeout has a fixed value of 64 SDIO\_CK clock periods.

If the interrupt bit is set in the command register, the timer is disabled and the CPSM waits for an interrupt request from one of the cards. If a pending bit is set in the command register, the CPSM enters the Pend state, and waits for a CmdPend signal from the data path subunit. When CmdPend is detected, the CPSM moves to the Send state. This enables the data counter to trigger the stop command transmission.

*Note:* The CPSM remains in the Idle state for at least eight SDIO\_CK periods to meet the  $N_{CC}$  and  $N_{RC}$  timing constraints.  $N_{CC}$  is the minimum delay between two host commands, and  $N_{RC}$  is the minimum delay between the host command and the card response.

Figure 216. SDIO command transfer



- Command format
  - Command: a command is a token that starts an operation. Command are sent from the host either to a single card (addressed command) or to all connected cards (broadcast command are available for MMC V3.31 or previous). Commands are transferred serially on the CMD line. All commands have a fixed length of 48 bits. The general format for a command token for MultiMediaCards, SD-Memory cards and SDIO-Cards is shown in [Table 135](#). CE-ATA commands are an extension of MMC commands V4.2, and so have the same format.   
 The command path operates in a half-duplex mode, so that commands and responses can either be sent or received. If the CPSM is not in the Send state, the SDIO\_CMD output is in the Hi-Z state, as shown in [Figure 216 on page 532](#). Data on SDIO\_CMD are synchronous with the rising edge of SDIO\_CK. [Table](#) shows the command format.

Table 135. Command format

Bit position	Width	Value	Description
47	1	0	Start bit
46	1	1	Transmission bit
[45:40]	6	-	Command index
[39:8]	32	-	Argument
[7:1]	7	-	CRC7
0	1	1	End bit

- Response: a response is a token that is sent from an addressed card (or synchronously from all connected cards for MMC V3.31 or previous), to the host as an answer to a previously received command. Responses are transferred serially on the CMD line.

The SDIO supports two response types. Both use CRC error checking:

- 48 bit short response
- 136 bit long response

*Note:* If the response does not contain a CRC (CMD1 response), the device driver must ignore the CRC failed status.

**Table 136. Short response format**

Bit position	Width	Value	Description
47	1	0	Start bit
46	1	0	Transmission bit
[45:40]	6	-	Command index
[39:8]	32	-	Argument
[7:1]	7	-	CRC7(or 1111111)
0	1	1	End bit

**Table 137. Long response format**

Bit position	Width	Value	Description
135	1	0	Start bit
134	1	0	Transmission bit
[133:128]	6	111111	Reserved
[127:1]	127	-	CID or CSD (including internal CRC7)
0	1	1	End bit

The command register contains the command index (six bits sent to a card) and the command type. These determine whether the command requires a response, and whether the response is 48 or 136 bits long (see [Section 21.9.4 on page 567](#)). The command path implements the status flags shown in [Table 138](#):

**Table 138. Command path status flags**

Flag	Description
CMDREND	Set if response CRC is OK.
CCRCFAIL	Set if response CRC fails.
CMDSENT	Set when command (that does not require response) is sent
CTIMEOUT	Response timeout.
CMDACT	Command transfer in progress.

The CRC generator calculates the CRC checksum for all bits before the CRC code. This includes the start bit, transmitter bit, command index, and command argument (or card status). The CRC checksum is calculated for the first 120 bits of CID or CSD for the long response format. Note that the start bit, transmitter bit and the six reserved bits are not used in the CRC calculation.

The CRC checksum is a 7-bit value:

$$\text{CRC}[6:0] = \text{Remainder} [(M(x) * x^7) / G(x)]$$

$$G(x) = x^7 + x^3 + 1$$

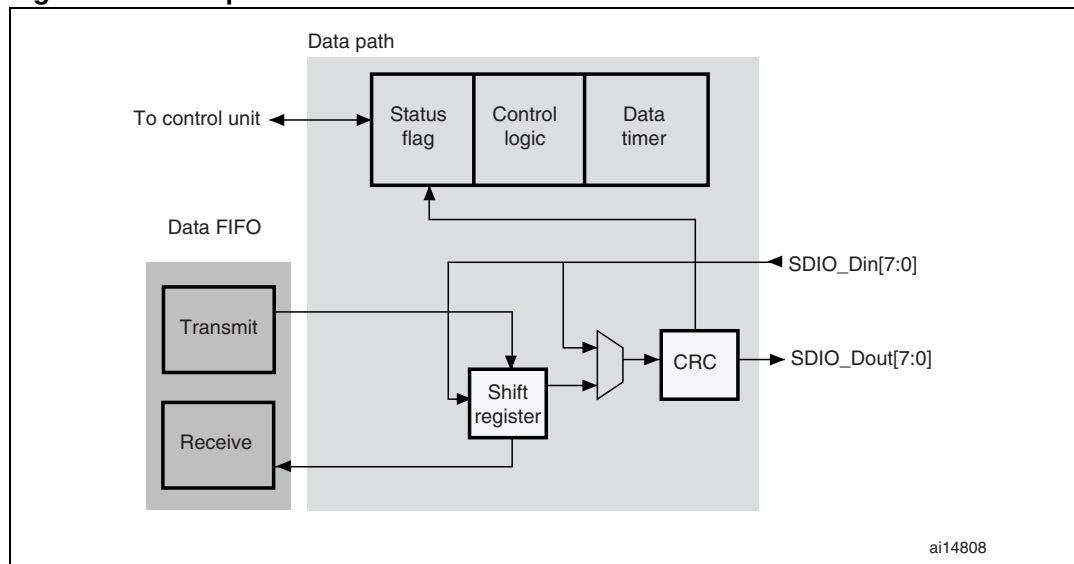
$$M(x) = (\text{start bit}) * x^{39} + \dots + (\text{last bit before CRC}) * x^0, \text{ or}$$

$$M(x) = (\text{start bit}) * x^{119} + \dots + (\text{last bit before CRC}) * x^0$$

## Data path

The data path subunit transfers data to and from cards. [Figure 217](#) shows a block diagram of the data path.

**Figure 217. Data path**



The card databus width can be programmed using the clock control register. If the 4-bit wide bus mode is enabled, data is transferred at four bits per clock cycle over all four data signals (SDIO\_D[3:0]). If the 8-bit wide bus mode is enabled, data is transferred at eight bits per clock cycle over all eight data signals (SDIO\_D[7:0]). If the wide bus mode is not enabled, only one bit per clock cycle is transferred over SDIO\_D0.

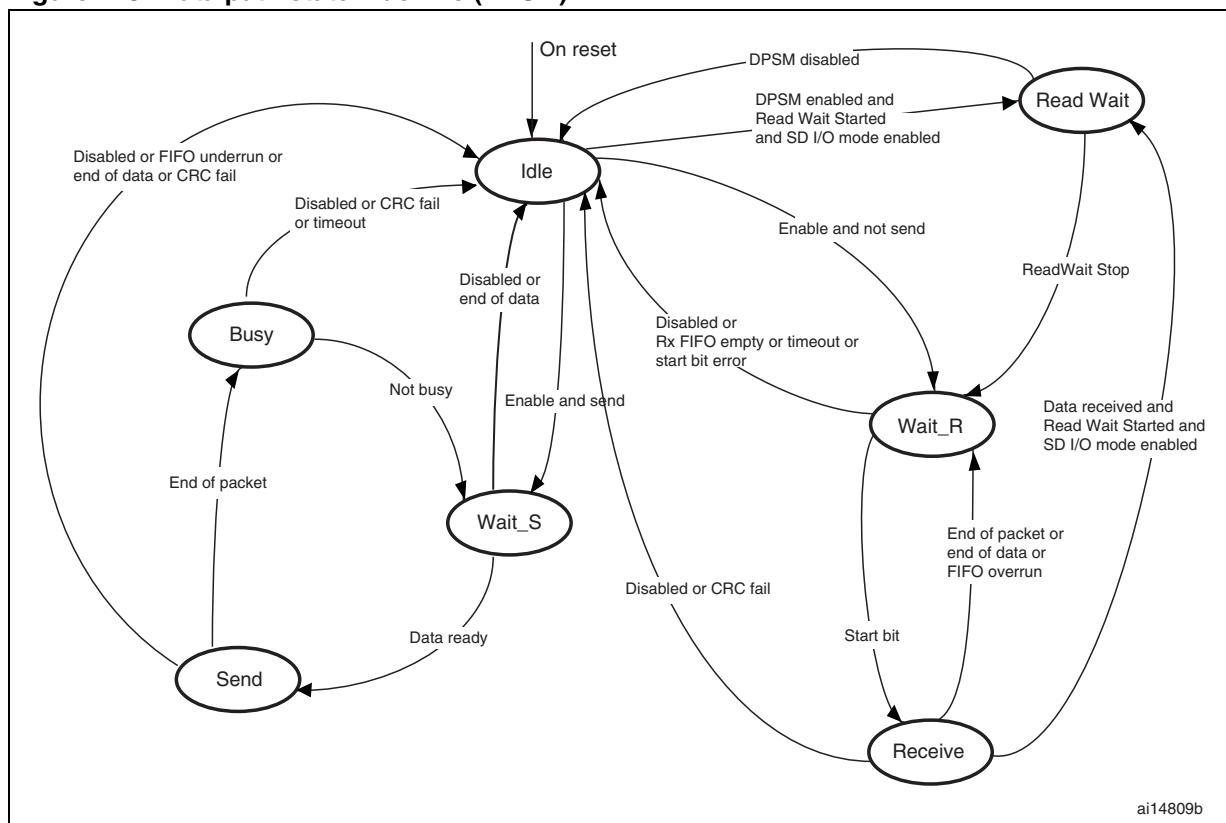
Depending on the transfer direction (send or receive), the data path state machine (DPSM) moves to the Wait\_S or Wait\_R state when it is enabled:

- Send: the DPSM moves to the Wait\_S state. If there is data in the transmit FIFO, the DPSM moves to the Send state, and the data path subunit starts sending data to a card.
- Receive: the DPSM moves to the Wait\_R state and waits for a start bit. When it receives a start bit, the DPSM moves to the Receive state, and the data path subunit starts receiving data from a card.

### Data path state machine (DPSM)

The DPSM operates at SDIO\_CK frequency. Data on the card bus signals is synchronous to the rising edge of SDIO\_CK. The DPSM has six states, as shown in [Figure 218: Data path state machine \(DPSM\)](#).

Figure 218. Data path state machine (DPSM)



- Idle: the data path is inactive, and the SDIO\_D[7:0] outputs are in Hi-Z. When the data control register is written and the enable bit is set, the DPSM loads the data counter with a new value and, depending on the data direction bit, moves to either the Wait\_S or the Wait\_R state.
- Wait\_R: if the data counter equals zero, the DPSM moves to the Idle state when the receive FIFO is empty. If the data counter is not zero, the DPSM waits for a start bit on SDIO\_D. The DPSM moves to the Receive state if it receives a start bit before a timeout, and loads the data block counter. If it reaches a timeout before it detects a start bit, or a start bit error occurs, it moves to the Idle state and sets the timeout status flag.
- Receive: serial data received from a card is packed in bytes and written to the data FIFO. Depending on the transfer mode bit in the data control register, the data transfer mode can be either block or stream:
  - In block mode, when the data block counter reaches zero, the DPSM waits until it receives the CRC code. If the received code matches the internally generated CRC code, the DPSM moves to the Wait\_R state. If not, the CRC fail status flag is set and the DPSM moves to the Idle state.
  - In stream mode, the DPSM receives data while the data counter is not zero. When the counter is zero, the remaining data in the shift register is written to the data FIFO, and the DPSM moves to the Wait\_R state.

If a FIFO overrun error occurs, the DPSM sets the FIFO error flag and moves to the Idle state:
- Wait\_S: the DPSM moves to the Idle state if the data counter is zero. If not, it waits until the data FIFO empty flag is deasserted, and moves to the Send state.

*Note:* The DPSM remains in the Wait\_S state for at least two clock periods to meet the  $N_{WR}$  timing requirements, where  $N_{WR}$  is the number of clock cycles between the reception of the card response and the start of the data transfer from the host.

- Send: the DPSM starts sending data to a card. Depending on the transfer mode bit in the data control register, the data transfer mode can be either block or stream:
  - In block mode, when the data block counter reaches zero, the DPSM sends an internally generated CRC code and end bit, and moves to the Busy state.
  - In stream mode, the DPSM sends data to a card while the enable bit is high and the data counter is not zero. It then moves to the Idle state.

If a FIFO underrun error occurs, the DPSM sets the FIFO error flag and moves to the Idle state.

- Busy: the DPSM waits for the CRC status flag:
  - If it does not receive a positive CRC status, it moves to the Idle state and sets the CRC fail status flag.
  - If it receives a positive CRC status, it moves to the Wait\_S state if SDIO\_D0 is not low (the card is not busy).

If a timeout occurs while the DPSM is in the Busy state, it sets the data timeout flag and moves to the Idle state.

The data timer is enabled when the DPSM is in the Wait\_R or Busy state, and generates the data timeout error:

- When transmitting data, the timeout occurs if the DPSM stays in the Busy state for longer than the programmed timeout period
- When receiving data, the timeout occurs if the end of the data is not true, and if the DPSM stays in the Wait\_R state for longer than the programmed timeout period.
- **Data:** data can be transferred from the card to the host or vice versa. Data is transferred via the data lines. They are stored in a FIFO of 32 words, each word is 32 bits wide.

**Table 139. Data token format**

Description	Start bit	Data	CRC16	End bit
Block Data	0	-	yes	1
Stream Data	0	-	no	1

### Data FIFO

The data FIFO (first-in-first-out) subunit is a data buffer with a transmit and receive unit.

The FIFO contains a 32-bit wide, 32-word deep data buffer, and transmit and receive logic. Because the data FIFO operates in the AHB clock domain (HCLK/2), all signals from the subunits in the SDIO clock domain (SDIOCLK) are resynchronized.



Depending on the TXACT and RXACT flags, the FIFO can be disabled, transmit enabled, or receive enabled. TXACT and RXACT are driven by the data path subunit and are mutually exclusive:

- The transmit FIFO refers to the transmit logic and data buffer when TXACT is asserted
- The receive FIFO refers to the receive logic and data buffer when RXACT is asserted
- **Transmit FIFO:**  
Data can be written to the transmit FIFO through the AHB interface when the SDIO is enabled for transmission.  
The transmit FIFO is accessible via 32 sequential addresses. The transmit FIFO contains a data output register that holds the data word pointed to by the read pointer. When the data path subunit has loaded its shift register, it increments the read pointer and drives new data out.  
If the transmit FIFO is disabled, all status flags are deasserted. The data path subunit asserts TXACT when it transmits data.

**Table 140. Transmit FIFO status flags**

Flag	Description
TXFIFOV	Set to high when all 32 transmit FIFO words contain valid data.
TXFIFOE	Set to high when the transmit FIFO does not contain valid data.
TXFIFOHE	Set to high when 8 or more transmit FIFO words are empty. This flag can be used as a DMA request.
TXDAVL	Set to high when the transmit FIFO contains valid data. This flag is the inverse of the TXFIFOE flag.
TXUNDERR	Set to high when an underrun error occurs. This flag is cleared by writing to the SDIO Clear register.

- **Receive FIFO**  
When the data path subunit receives a word of data, it drives the data on the write databus. The write pointer is incremented after the write operation completes. On the read side, the contents of the FIFO word pointed to by the current value of the read pointer is driven onto the read databus. If the receive FIFO is disabled, all status flags are deasserted, and the read and write pointers are reset. The data path subunit asserts RXACT when it receives data. [Table 141](#) lists the receive FIFO status flags. The receive FIFO is accessible via 32 sequential addresses.

**Table 141. Receive FIFO status flags**

Flag	Description
RXFIFO	Set to high when all 32 receive FIFO words contain valid data
RXFIFOE	Set to high when the receive FIFO does not contain valid data.
RXFIFOHF	Set to high when 8 or more receive FIFO words contain valid data. This flag can be used as a DMA request.
RXDAVL	Set to high when the receive FIFO is not empty. This flag is the inverse of the RXFIFOE flag.
RXOVERR	Set to high when an overrun error occurs. This flag is cleared by writing to the SDIO Clear register.

### 21.3.2 SDIO AHB interface

The AHB interface generates the interrupt and DMA requests, and accesses the SDIO adapter registers and the data FIFO. It consists of a data path, register decoder, and interrupt/DMA logic.

#### SDIO interrupts

The interrupt logic generates an interrupt request signal that is asserted when at least one of the selected status flags is high. A mask register is provided to allow selection of the conditions that will generate an interrupt. A status flag generates the interrupt request if a corresponding mask flag is set.

#### SDIO/DMA interface: procedure for data transfers between the SDIO and memory

In the example shown, the transfer is from the SDIO host controller to an MMC (512 bytes using CMD24 (WRITE\_BLOCK)). The SDIO FIFO is filled by data stored in a memory using the DMA controller.

1. Do the card identification process
2. Increase the SDIO\_CK frequency
3. Select the card by sending CMD7
4. Configure the DMA2 as follows:
  - a) Enable DMA2 controller and clear any pending interrupts
  - b) Program the DMA2\_Channel4 source address register with the memory location's base address and DMA2\_Channel4 destination address register with the SDIO\_FIFO register address
  - c) Program DMA2\_Channel4 control register (memory increment, not peripheral increment, peripheral and source width is word size)
  - d) Enable DMA2\_Channel4

5. Send CMD24 (WRITE\_BLOCK) as follows:
  - a) Program the SDIO data length register (SDIO data timer register should be already programmed before the card identification process)
  - b) Program the SDIO argument register with the address location of the card where data is to be transferred
  - c) Program the SDIO command register: CmdIndex with 24 (WRITE\_BLOCK); WaitResp with '1' (SDIO card host waits for a response); CPSMEN with '1' (SDIO card host enabled to send a command). Other fields are at their reset value.
  - d) Wait for SDIO\_STA[6] = CMDREND interrupt, then program the SDIO data control register: DTEN with '1' (SDIO card host enabled to send data); DTDIR with '0' (from controller to card); DTMODE with '0' (block data transfer); DMAEN with '1' (DMA enabled); DBLOCKSIZE with 0x9 (512 bytes). Other fields are don't care.
  - e) Wait for SDIO\_STA[10] = DBCKEND
6. Check that no channels are still enabled by polling the DMA Enabled Channel Status register.

## 21.4 Card functional description

### 21.4.1 Card identification mode

While in card identification mode the host resets all cards, validates the operation voltage range, identifies cards and sets a relative card address (RCA) for each card on the bus. All data communications in the card identification mode use the command line (CMD) only.

### 21.4.2 Card reset

The `GO_IDLE_STATE` command (CMD0) is the software reset command and it puts the MultiMediaCard and SD memory in the Idle state. The `IO_RW_DIRECT` command (CMD52) resets the SD I/O card. After power-up or CMD0, all cards output bus drivers are in the high-impedance state and the cards are initialized with a default relative card address (RCA=0x0001) and with a default driver stage register setting (lowest speed, highest driving current capability).

### 21.4.3 Operating voltage range validation

All cards can communicate with the SDIO card host using any operating voltage within the specification range. The supported minimum and maximum  $V_{DD}$  values are defined in the operation conditions register (OCR) on the card.

Cards that store the card identification number (CID) and card specific data (CSD) in the payload memory are able to communicate this information only under data-transfer  $V_{DD}$  conditions. When the SDIO card host module and the card have incompatible  $V_{DD}$  ranges, the card is not able to complete the identification cycle and cannot send CSD data. For this purpose, the special commands, `SEND_OP_COND` (CMD1), `SD_APP_OP_COND` (ACMD41 for SD Memory), and `IO_SEND_OP_COND` (CMD5 for SD I/O), are designed to provide a mechanism to identify and reject cards that do not match the  $V_{DD}$  range desired by the SDIO card host. The SDIO card host sends the required  $V_{DD}$  voltage window as the operand of these commands. Cards that cannot perform data transfer in the specified range disconnect from the bus and go to the inactive state.

By using these commands without including the voltage range as the operand, the SDIO card host can query each card and determine the common voltage range before placing out-of-range cards in the inactive state. This query is used when the SDIO card host is able to select a common voltage range or when the user requires notification that cards are not usable.

#### 21.4.4 Card identification process

The card identification process differs for MultiMediaCards and SD cards. For MultiMediaCard cards, the identification process starts at clock rate  $F_{od}$ . The SDIO\_CMD line output drivers are open-drain and allow parallel card operation during this process. The registration process is accomplished as follows:

1. The bus is activated.
2. The SDIO card host broadcasts `SEND_OP_COND` (CMD1) to receive operation conditions.
3. The response is the wired AND operation of the operation condition registers from all cards.
4. Incompatible cards are placed in the inactive state.
5. The SDIO card host broadcasts `ALL_SEND_CID` (CMD2) to all active cards.
6. The active cards simultaneously send their CID numbers serially. Cards with outgoing CID bits that do not match the bits on the command line stop transmitting and must wait for the next identification cycle. One card successfully transmits a full CID to the SDIO card host and enters the Identification state.
7. The SDIO card host issues `SET_RELATIVE_ADDR` (CMD3) to that card. This new address is called the relative card address (RCA); it is shorter than the CID and addresses the card. The assigned card changes to the Standby state, it does not react to further identification cycles, and its output switches from open-drain to push-pull.
8. The SDIO card host repeats steps 5 through 7 until it receives a timeout condition.

For the SD card, the identification process starts at clock rate  $F_{od}$ , and the SDIO\_CMD line output drives are push-pull drivers instead of open-drain. The registration process is accomplished as follows:

1. The bus is activated.
2. The SDIO card host broadcasts `SD_APP_OP_COND` (ACMD41).
3. The cards respond with the contents of their operation condition registers.
4. The incompatible cards are placed in the inactive state.
5. The SDIO card host broadcasts `ALL_SEND_CID` (CMD2) to all active cards.
6. The cards send back their unique card identification numbers (CIDs) and enter the Identification state.
7. The SDIO card host issues `SET_RELATIVE_ADDR` (CMD3) to an active card with an address. This new address is called the relative card address (RCA); it is shorter than the CID and addresses the card. The assigned card changes to the Standby state. The SDIO card host can reissue this command to change the RCA. The RCA of the card is the last assigned value.
8. The SDIO card host repeats steps 5 through 7 with all active cards.

For the SD I/O card, the registration process is accomplished as follows:

1. The bus is activated.
2. The SDIO card host sends `IO_SEND_OP_COND` (CMD5).
3. The cards respond with the contents of their operation condition registers.
4. The incompatible cards are set to the inactive state.
5. The SDIO card host issues `SET_RELATIVE_ADDR` (CMD3) to an active card with an address. This new address is called the relative card address (RCA); it is shorter than the CID and addresses the card. The assigned card changes to the Standby state. The SDIO card host can reissue this command to change the RCA. The RCA of the card is the last assigned value.

### 21.4.5 Block write

During block write (CMD24 - 27) one or more blocks of data are transferred from the host to the card with a CRC appended to the end of each block by the host. A card supporting block write is always able to accept a block of data defined by `WRITE_BLK_LEN`. If the CRC fails, the card indicates the failure on the SDIO\_D line and the transferred data are discarded and not written, and all further transmitted blocks (in multiple block write mode) are ignored.

If the host uses partial blocks whose accumulated length is not block aligned and, block misalignment is not allowed (CSD parameter `WRITE_BLK_MISALIGN` is not set), the card will detect the block misalignment error before the beginning of the first misaligned block. (`ADDRESS_ERROR` error bit is set in the status register). The write operation will also be aborted if the host tries to write over a write-protected area. In this case, however, the card will set the `WP_VIOLATION` bit.

Programming of the CID and CSD registers does not require a previous block length setting. The transferred data is also CRC protected. If a part of the CSD or CID register is stored in ROM, then this unchangeable part must match the corresponding part of the receive buffer. If this match fails, then the card reports an error and does not change any register contents. Some cards may require long and unpredictable times to write a block of data. After receiving a block of data and completing the CRC check, the card begins writing and holds the SDIO\_D line low if its write buffer is full and unable to accept new data from a new `WRITE_BLOCK` command. The host may poll the status of the card with a `SEND_STATUS` command (CMD13) at any time, and the card will respond with its status. The `READY_FOR_DATA` status bit indicates whether the card can accept new data or whether the write process is still in progress. The host may deselect the card by issuing CMD7 (to select a different card), which will place the card in the Disconnect state and release the SDIO\_D line(s) without interrupting the write operation. When reselecting the card, it will reactivate busy indication by pulling SDIO\_D to low if programming is still in progress and the write buffer is unavailable.

### 21.4.6 Block read

In Block read mode the basic unit of data transfer is a block whose maximum size is defined in the CSD (`READ_BLK_LEN`). If `READ_BLK_PARTIAL` is set, smaller blocks whose start and end addresses are entirely contained within one physical block (as defined by `READ_BLK_LEN`) may also be transmitted. A CRC is appended to the end of each block, ensuring data transfer integrity. CMD17 (`READ_SINGLE_BLOCK`) initiates a block read and after completing the transfer, the card returns to the Transfer state.

CMD18 (`READ_MULTIPLE_BLOCK`) starts a transfer of several consecutive blocks.

The host can abort reading at any time, within a multiple block operation, regardless of its type. Transaction abort is done by sending the stop transmission command.

If the card detects an error (for example, out of range, address misalignment or internal error) during a multiple block read operation (both types) it stops the data transmission and remains in the data state. The host must then abort the operation by sending the stop transmission command. The read error is reported in the response to the stop transmission command.

If the host sends a stop transmission command after the card transmits the last block of a multiple block operation with a predefined number of blocks, it is responded to as an illegal command, since the card is no longer in the data state. If the host uses partial blocks whose accumulated length is not block-aligned and block misalignment is not allowed, the card detects a block misalignment error condition at the beginning of the first misaligned block (ADDRESS\_ERROR error bit is set in the status register).

### 21.4.7 Stream access, stream write and stream read (MultiMediaCard only)

In stream mode, data is transferred in bytes and no CRC is appended at the end of each block.

#### Stream write (MultiMediaCard only)

WRITE\_DAT\_UNTIL\_STOP (CMD20) starts the data transfer from the SDIO card host to the card, beginning at the specified address and continuing until the SDIO card host issues a stop command. When partial blocks are allowed (CSD parameter WRITE\_BL\_PARTIAL is set), the data stream can start and stop at any address within the card address space, otherwise it can only start and stop at block boundaries. Because the amount of data to be transferred is not determined in advance, a CRC cannot be used. When the end of the memory range is reached while sending data and no stop command is sent by the SD card host, any additional transferred data are discarded.

The maximum clock frequency for a stream write operation is given by the following equation fields of the card-specific data register:

$$\text{Maximumspeed} = \text{MIN}(\text{TRANSPEED}, \frac{(8 \times 2^{\text{writeblen}})(-\text{NSAC})}{\text{TAAC} \times \text{R2WFACTOR}})$$

- Maximumspeed = maximum write frequency
- TRANSPEED = maximum data transfer rate
- writeblen = maximum write data block length
- NSAC = data read access time 2 in CLK cycles
- TAAC = data read access time 1
- R2WFACTOR = write speed factor

If the host attempts to use a higher frequency, the card may not be able to process the data and stop programming, set the OVERRUN error bit in the status register, and while ignoring all further data transfer, wait (in the receive data state) for a stop command. The write operation is also aborted if the host tries to write over a write-protected area. In this case, however, the card sets the WP\_VIOLATION bit.

### Stream read (MultiMediaCard only)

READ\_DAT\_UNTIL\_STOP (CMD11) controls a stream-oriented data transfer.

This command instructs the card to send its data, starting at a specified address, until the SDIO card host sends STOP\_TRANSMISSION (CMD12). The stop command has an execution delay due to the serial command transmission and the data transfer stops after the end bit of the stop command. When the end of the memory range is reached while sending data and no stop command is sent by the SDIO card host, any subsequent data sent are considered undefined.

The maximum clock frequency for a stream read operation is given by the following equation and uses fields of the card specific data register.

$$\text{Maximumspeed} = \text{MIN}(\text{TRANSPEED}, \frac{(8 \times 2^{\text{readblen}})(-\text{NSAC})}{\text{TAAC} \times \text{R2WFACTOR}})$$

- Maximumspeed = maximum read frequency
- TRANSPEED = maximum data transfer rate
- readblen = maximum read data block length
- writeblen = maximum write data block length
- NSAC = data read access time 2 in CLK cycles
- TAAC = data read access time 1
- R2WFACTOR = write speed factor

If the host attempts to use a higher frequency, the card is not able to sustain data transfer. If this happens, the card sets the UNDERRUN error bit in the status register, aborts the transmission and waits in the data state for a stop command.

### 21.4.8 Erase: group erase and sector erase

The erasable unit of the MultiMediaCard is the erase group. The erase group is measured in write blocks, which are the basic writable units of the card. The size of the erase group is a card-specific parameter and defined in the CSD.

The host can erase a contiguous range of Erase Groups. Starting the erase process is a three-step sequence.

First the host defines the start address of the range using the ERASE\_GROUP\_START (CMD35) command, next it defines the last address of the range using the ERASE\_GROUP\_END (CMD36) command and, finally, it starts the erase process by issuing the ERASE (CMD38) command. The address field in the erase commands is an Erase Group address in byte units. The card ignores all LSBs below the Erase Group size, effectively rounding the address down to the Erase Group boundary.

If an erase command is received out of sequence, the card sets the ERASE\_SEQ\_ERROR bit in the status register and resets the whole sequence.

If an out-of-sequence (neither of the erase commands, except SEND\_STATUS) command received, the card sets the ERASE\_RESET status bit in the status register, resets the erase sequence and executes the last command.

If the erase range includes write protected blocks, they are left intact and only nonprotected blocks are erased. The WP\_ERASE\_SKIP status bit in the status register is set.

The card indicates that an erase is in progress by holding SDIO\_D low. The actual erase time may be quite long, and the host may issue CMD7 to deselect the card.

### 21.4.9 Wide bus selection or deselection

Wide bus (4-bit bus width) operation mode is selected or deselected using SET\_BUS\_WIDTH (ACMD6). The default bus width after power-up or GO\_IDLE\_STATE (CMD0) is 1 bit. SET\_BUS\_WIDTH (ACMD6) is only valid in a transfer state, which means that the bus width can be changed only after a card is selected by SELECT/DESELECT\_CARD (CMD7).

### 21.4.10 Protection management

Three write protection methods for the cards are supported in the SDIO card host module:

1. internal card write protection (card responsibility)
2. mechanical write protection switch (SDIO card host module responsibility only)
3. password-protected card lock operation

#### Internal card write protection

Card data can be protected against write and erase. By setting the permanent or temporary write-protect bits in the CSD, the entire card can be permanently write-protected by the manufacturer or content provider. For cards that support write protection of groups of sectors by setting the WP\_GRP\_ENABLE bit in the CSD, portions of the data can be protected, and the write protection can be changed by the application. The write protection is in units of WP\_GRP\_SIZE sectors as specified in the CSD. The SET\_WRITE\_PROT and CLR\_WRITE\_PROT commands control the protection of the addressed group. The SEND\_WRITE\_PROT command is similar to a single block read command. The card sends a data block containing 32 write protection bits (representing 32 write protect groups starting at the specified address) followed by 16 CRC bits. The address field in the write protect commands is a group address in byte units.

The card ignores all LSBs below the group size.

#### Mechanical write protect switch

A mechanical sliding tab on the side of the card allows the user to set or clear the write protection on a card. When the sliding tab is positioned with the window open, the card is write-protected, and when the window is closed, the card contents can be changed. A matched switch on the socket side indicates to the SDIO card host module that the card is write-protected. The SDIO card host module is responsible for protecting the card. The position of the write protect switch is unknown to the internal circuitry of the card.

#### Password protect

The password protection feature enables the SDIO card host module to lock and unlock a card with a password. The password is stored in the 128-bit PWD register and its size is set in the 8-bit PWD\_LEN register. These registers are non-volatile so that a power cycle does not erase them. Locked cards respond to and execute certain commands. This means that the SDIO card host module is allowed to reset, initialize, select, and query for status, however it is not allowed to access data on the card. When the password is set (as indicated by a nonzero value of PWD\_LEN), the card is locked automatically after power-up. As with the CSD and CID register write commands, the lock/unlock commands are available in the transfer state only. In this state, the command does not include an address argument and



the card must be selected before using it. The card lock/unlock commands have the structure and bus transaction types of a regular single-block write command. The transferred data block includes all of the required information for the command (the password setting mode, the PWD itself, and card lock/unlock). The command data block size is defined by the SDIO card host module before it sends the card lock/unlock command, and has the structure shown in [Table 155](#).

The bit settings are as follows:

- ERASE: setting it forces an erase operation. All other bits must be zero, and only the command byte is sent
- LOCK\_UNLOCK: setting it locks the card. LOCK\_UNLOCK can be set simultaneously with SET\_PWD, however not with CLR\_PWD
- CLR\_PWD: setting it clears the password data
- SET\_PWD: setting it saves the password data to memory
- PWD\_LEN: it defines the length of the password in bytes
- PWD: the password (new or currently used, depending on the command)

The following sections list the command sequences to set/reset a password, lock/unlock the card, and force an erase.

### Setting the password

1. Select a card (`SELECT/DESELECT_CARD`, `CMD7`), if none is already selected.
2. Define the block length (`SET_BLOCKLEN`, `CMD16`) to send, given by the 8-bit card lock/unlock mode, the 8-bit `PWD_LEN`, and the number of bytes of the new password. When a password replacement is done, the block size must take into account that both the old and the new passwords are sent with the command.
3. Send `LOCK/UNLOCK` (`CMD42`) with the appropriate data block size on the data line including the 16-bit CRC. The data block indicates the mode (`SET_PWD = 1`), the length (`PWD_LEN`), and the password (`PWD`) itself. When a password replacement is done, the length value (`PWD_LEN`) includes the length of both passwords, the old and the new one, and the `PWD` field includes the old password (currently used) followed by the new password.
4. When the password is matched, the new password and its size are saved into the `PWD` and `PWD_LEN` fields, respectively. When the old password sent does not correspond (in size and/or content) to the expected password, the `LOCK_UNLOCK_FAILED` error bit is set in the card status register, and the password is not changed.

The password length field (`PWD_LEN`) indicates whether a password is currently set. When this field is nonzero, there is a password set and the card locks itself after power-up. It is possible to lock the card immediately in the current power session by setting the `LOCK_UNLOCK` bit (while setting the password) or sending an additional command for card locking.

### Resetting the password

1. Select a card (`SELECT/DESELECT_CARD`, CMD7), if none is already selected.
2. Define the block length (`SET_BLOCKLEN`, CMD16) to send, given by the 8-bit card lock/unlock mode, the 8-bit `PWD_LEN`, and the number of bytes in the currently used password.
3. Send `LOCK/UNLOCK` (CMD42) with the appropriate data block size on the data line including the 16-bit CRC. The data block indicates the mode (`CLR_PWD = 1`), the length (`PWD_LEN`) and the password (`PWD`) itself. The `LOCK_UNLOCK` bit is ignored.
4. When the password is matched, the `PWD` field is cleared and `PWD_LEN` is set to 0. When the password sent does not correspond (in size and/or content) to the expected password, the `LOCK_UNLOCK_FAILED` error bit is set in the card status register, and the password is not changed.

### Locking a card

1. Select a card (`SELECT/DESELECT_CARD`, CMD7), if none is already selected.
2. Define the block length (`SET_BLOCKLEN`, CMD16) to send, given by the 8-bit card lock/unlock mode (byte 0 in [Table 155](#)), the 8-bit `PWD_LEN`, and the number of bytes of the current password.
3. Send `LOCK/UNLOCK` (CMD42) with the appropriate data block size on the data line including the 16-bit CRC. The data block indicates the mode (`LOCK_UNLOCK = 1`), the length (`PWD_LEN`), and the password (`PWD`) itself.
4. When the password is matched, the card is locked and the `CARD_IS_LOCKED` status bit is set in the card status register. When the password sent does not correspond (in size and/or content) to the expected password, the `LOCK_UNLOCK_FAILED` error bit is set in the card status register, and the lock fails.

It is possible to set the password and to lock the card in the same sequence. In this case, the SDIO card host module performs all the required steps for setting the password (see [Setting the password on page 545](#)), however it is necessary to set the `LOCK_UNLOCK` bit in Step 3 when the new password command is sent.

When the password is previously set (`PWD_LEN` is not 0), the card is locked automatically after power on reset. An attempt to lock a locked card or to lock a card that does not have a password fails and the `LOCK_UNLOCK_FAILED` error bit is set in the card status register.

### Unlocking the card

1. Select a card (`SELECT/DESELECT_CARD`, CMD7), if none is already selected.
2. Define the block length (`SET_BLOCKLEN`, CMD16) to send, given by the 8-bit cardlock/unlock mode (byte 0 in [Table 155](#)), the 8-bit `PWD_LEN`, and the number of bytes of the current password.
3. Send `LOCK/UNLOCK` (CMD42) with the appropriate data block size on the data line including the 16-bit CRC. The data block indicates the mode (`LOCK_UNLOCK = 0`), the length (`PWD_LEN`), and the password (`PWD`) itself.
4. When the password is matched, the card is unlocked and the `CARD_IS_LOCKED` status bit is cleared in the card status register. When the password sent is not correct in size and/or content and does not correspond to the expected password, the `LOCK_UNLOCK_FAILED` error bit is set in the card status register, and the card remains locked.

The unlocking function is only valid for the current power session. When the PWD field is not clear, the card is locked automatically on the next power-up.

An attempt to unlock an unlocked card fails and the LOCK\_UNLOCK\_FAILED error bit is set in the card status register.

### Forcing erase

If the user has forgotten the password (PWD content), it is possible to access the card after clearing all the data on the card. This forced erase operation erases all card data and all password data.

1. Select a card (SELECT/DESELECT\_CARD, CMD7), if none is already selected.
2. Set the block length (SET\_BLOCKLEN, CMD16) to 1 byte. Only the 8-bit card lock/unlock byte (byte 0 in [Table 155](#)) is sent.
3. Send LOCK/UNLOCK (CMD42) with the appropriate data byte on the data line including the 16-bit CRC. The data block indicates the mode (ERASE = 1). All other bits must be zero.
4. When the ERASE bit is the only bit set in the data field, all card contents are erased, including the PWD and PWD\_LEN fields, and the card is no longer locked. When any other bits are set, the LOCK\_UNLOCK\_FAILED error bit is set in the card status register and the card retains all of its data, and remains locked.

An attempt to use a force erase on an unlocked card fails and the LOCK\_UNLOCK\_FAILED error bit is set in the card status register.

### 21.4.11 Card status register

The response format R1 contains a 32-bit field named card status. This field is intended to transmit the card status information (which may be stored in a local status register) to the host. If not specified otherwise, the status entries are always related to the previously issued command.

[Table 142](#) defines the different entries of the status. The type and clear condition fields in the table are abbreviated as follows:

Type:

- E: error bit
- S: status bit
- R: detected and set for the actual command response
- X: detected and set during command execution. The SDIO card host must poll the card by issuing the status command to read these bits.

Clear condition:

- A: according to the card current state
- B: always related to the previous command. Reception of a valid command clears it (with a delay of one command)
- C: clear by read

Table 142. Card status

Bits	Identifier	Type	Value	Description	Clear condition
31	ADDRESS_OUT_OF_RANGE	E R X	'0'= no error '1'= error	The command address argument was out of the allowed range for this card. A multiple block or stream read/write operation is (although started in a valid address) attempting to read or write beyond the card capacity.	C
30	ADDRESS_MISALIGN		'0'= no error '1'= error	The commands address argument (in accordance with the currently set block length) positions the first data block misaligned to the card physical blocks. A multiple block read/write operation (although started with a valid address/block-length combination) is attempting to read or write a data block which is not aligned with the physical blocks of the card.	C
29	BLOCK_LEN_ERROR		'0'= no error '1'= error	Either the argument of a SET_BLOCKLEN command exceeds the maximum value allowed for the card, or the previously defined block length is illegal for the current command (e.g. the host issues a write command, the current block length is smaller than the maximum allowed value for the card and it is not allowed to write partial blocks)	C
28	ERASE_SEQ_ERROR		'0'= no error '1'= error	An error in the sequence of erase commands occurred.	C
27	ERASE_PARAM	E X	'0'= no error '1'= error	An invalid selection of erase groups for erase occurred.	C
26	WP_VIOLATION	E X	'0'= no error '1'= error	Attempt to program a write-protected block.	C
25	CARD_IS_LOCKED	S R	'0' = card unlocked '1' = card locked	When set, signals that the card is locked by the host	A
24	LOCK_UNLOCK_FAILED	E X	'0'= no error '1'= error	Set when a sequence or password error has been detected in lock/unlock card command	C
23	COM_CRC_ERROR	E R	'0'= no error '1'= error	The CRC check of the previous command failed.	B
22	ILLEGAL_COMMAND	E R	'0'= no error '1'= error	Command not legal for the card state	B
21	CARD_ECC_FAILED	E X	'0'= success '1'= failure	Card internal ECC was applied but failed to correct the data.	C
20	CC_ERROR	E R	'0'= no error '1'= error	(Undefined by the standard) A card error occurred, which is not related to the host command.	C

Table 142. Card status (continued)

Bits	Identifier	Type	Value	Description	Clear condition
19	ERROR	E X	'0'= no error '1'= error	(Undefined by the standard) A generic card error related to the (and detected during) execution of the last host command (e.g. read or write failures).	C
18	Reserved				
17	Reserved				
16	CID/CSD_OVERWRITE	E X	'0'= no error '1'= error	Can be either of the following errors: – The CID register has already been written and cannot be overwritten – The read-only section of the CSD does not match the card contents – An attempt to reverse the copy (set as original) or permanent WP (unprotected) bits was made	C
15	WP_ERASE_SKIP	E X	'0'= not protected '1'= protected	<b>Set when only partial address space was erased due to existing write</b>	C
14	CARD_ECC_DISABLED	S X	'0'= enabled '1'= disabled	The command has been executed without using the internal ECC.	A
13	ERASE_RESET		'0'= cleared '1'= set	An erase sequence was cleared before executing because an out of erase sequence command was received (commands other than CMD35, CMD36, CMD38 or CMD13)	C
12:9	CURRENT_STATE	S R	0 = Idle 1 = Ready 2 = Ident 3 = Stby 4 = Tran 5 = Data 6 = Rcv 7 = Prg 8 = Dis 9 = Btst 10-15 = reserved	The state of the card when receiving the command. If the command execution causes a state change, it will be visible to the host in the response on the next command. The four bits are interpreted as a binary number between 0 and 15.	B
8	READY_FOR_DATA	S R	'0'= not ready '1' = ready	Corresponds to buffer empty signalling on the bus	
7	SWITCH_ERROR	E X	'0'= no error '1'= switch error	If set, the card did not switch to the expected mode as requested by the SWITCH command	B
6	Reserved				
5	APP_CMD	S R	'0' = Disabled '1' = Enabled	The card will expect ACMD, or an indication that the command has been interpreted as ACMD	C
4	Reserved for SD I/O Card				

Table 142. Card status (continued)

Bits	Identifier	Type	Value	Description	Clear condition
3	AKE_SEQ_ERROR	E R	'0'= no error '1'= error	Error in the sequence of the authentication process	C
2	Reserved for application specific commands				
1	Reserved for manufacturer test mode				
0					

### 21.4.12 SD status register

The SD status contains status bits that are related to the SD memory card proprietary features and may be used for future application-specific usage. The size of the SD Status is one data block of 512 bits. The contents of this register are transmitted to the SDIO card host if ACMD13 is sent (CMD55 followed with CMD13). ACMD13 can be sent to a card in transfer state only (card is selected).

[Table 143](#) defines the different entries of the SD status register. The type and clear condition fields in the table are abbreviated as follows:

Type:

- E: error bit
- S: status bit
- R: detected and set for the actual command response
- X: detected and set during command execution. The SDIO card Host must poll the card by issuing the status command to read these bits

Clear condition:

- A: according to the card current state
- B: always related to the previous command. Reception of a valid command clears it (with a delay of one command)
- C: clear by read

Table 143. SD status

Bits	Identifier	Type	Value	Description	Clear condition
511: 510	DAT_BUS_WIDTH	S R	'00'= 1 (default) '01'= reserved '10'= 4 bit width '11'= reserved	Shows the currently defined databus width that was defined by SET_BUS_WIDTH command	A
509	SECURED_MODE	S R	'0'= Not in the mode '1'= In Secured Mode	Card is in Secured Mode of operation (refer to the "SD Security Specification").	A
508: 496	Reserved				

Table 143. SD status (continued)

Bits	Identifier	Type	Value	Description	Clear condition
495: 480	SD_CARD_TYPE	S R	'00xxh'= SD Memory Cards as defined in Physical Spec Ver1.01-2.00 ('x'= don't care). The following cards are currently defined: '0000'= Regular SD RD/WR Card. '0001'= SD ROM Card	In the future, the 8 LSBs will be used to define different variations of an SD memory card (each bit will define different SD types). The 8 MSBs will be used to define SD Cards that do not comply with current SD physical layer specification.	A
479: 448	SIZE_OF_PROTECTED_AREA	S R	Size of protected area (See below)	(See below)	A
447: 440	SPEED_CLASS	S R	Speed Class of the card (See below)	(See below)	A
439: 432	PERFORMANCE_MOVE	S R	Performance of move indicated by 1 [MB/s] step. (See below)	(See below)	A
431:428	AU_SIZE	S R	Size of AU (See below)	(See below)	A
427:424	Reserved				
423:408	ERASE_SIZE	S R	Number of AUs to be erased at a time	(See below)	A
407:402	ERASE_TIMEOUT	S R	Timeout value for erasing areas specified by UNIT_OF_ERASE_AU	(See below)	A
401:400	ERASE_OFFSET	S R	Fixed offset value added to erase time.	(See below)	A
399:312	Reserved				
311:0	Reserved for Manufacturer				

### SIZE\_OF\_PROTECTED\_AREA

Setting this field differs between standard- and high-capacity cards. In the case of a standard-capacity card, the capacity of protected area is calculated as follows:

$$\text{Protected area} = \text{SIZE\_OF\_PROTECTED\_AREA} * \text{MULT} * \text{BLOCK\_LEN}.$$

SIZE\_OF\_PROTECTED\_AREA is specified by the unit in MULT\*BLOCK\_LEN.

In the case of a high-capacity card, the capacity of protected area is specified in this field:

$$\text{Protected area} = \text{SIZE\_OF\_PROTECTED\_AREA}$$

SIZE\_OF\_PROTECTED\_AREA is specified by the unit in bytes.

### SPEED\_CLASS

This 8-bit field indicates the speed class and the value can be calculated by  $P_{W}/2$  (where  $P_W$  is the write performance).

**Table 144. Speed class code field**

SPEED_CLASS	Value definition
00h	Class 0
01h	Class 2
02h	Class 4
03h	Class 6
04h – FFh	Reserved

**PERFORMANCE\_MOVE**

This 8-bit field indicates Pm (performance move) and the value can be set by 1 [MB/sec] steps. If the card does not move used RUs (recording units), Pm should be considered as infinity. Setting the field to FFh means infinity.

**Table 145. Performance move field**

PERFORMANCE_MOVE	Value definition
00h	Not defined
01h	1 [MB/sec]
02h	02h 2 [MB/sec]
-----	-----
FEh	254 [MB/sec]
FFh	Infinity

**AU\_SIZE**

This 4-bit field indicates the AU size and the value can be selected in the power of 2 base from 16 KB.

**Table 146. AU\_SIZE field**

AU_SIZE	Value definition
00h	Not defined
01h	16 KB
02h	32 KB
03h	64 KB
04h	128 KB
05h	256 KB
06h	512 KB
07h	1 MB
08h	2 MB



**Table 146. AU\_SIZE field (continued)**

AU_SIZE	Value definition
09h	4 MB
Ah – Fh	Reserved

The maximum AU size, which depends on the card capacity, is defined in [Table 147](#). The card can be set to any AU size between RU size and maximum AU size.

**Table 147. Maximum AU size**

Capacity	16 MB-64 MB	128 MB-256 MB	512 MB	1 GB-32 GB
Maximum AU Size	512 KB	1 MB	2 MB	4 MB

### ERASE\_SIZE

This 16-bit field indicates  $N_{ERASE}$ . When  $N_{ERASE}$  numbers of AUs are erased, the timeout value is specified by ERASE\_TIMEOUT (Refer to [ERASE\\_TIMEOUT](#)). The host should determine the proper number of AUs to be erased in one operation so that the host can show the progress of the erase operation. If this field is set to 0, the erase timeout calculation is not supported.

**Table 148. Erase size field**

ERASE_SIZE	Value definition
0000h	Erase timeout calculation is not supported.
0001h	1 AU
0002h	2 AU
0003h	3 AU
-----	-----
FFFFh	65535 AU

### ERASE\_TIMEOUT

This 6-bit field indicates  $T_{ERASE}$  and the value indicates the erase timeout from offset when multiple AUs are being erased as specified by ERASE\_SIZE. The range of ERASE\_TIMEOUT can be defined as up to 63 seconds and the card manufacturer can choose any combination of ERASE\_SIZE and ERASE\_TIMEOUT depending on the implementation. Determining ERASE\_TIMEOUT determines the ERASE\_SIZE.

**Table 149. Erase timeout field**

ERASE_TIMEOUT	Value definition
00	Erase timeout calculation is not supported.
01	1 [sec]
02	2 [sec]
03	3 [sec]

**Table 149. Erase timeout field (continued)**

ERASE_TIMEOUT	Value definition
-----	-----
63	63 [sec]

**ERASE\_OFFSET**

This 2-bit field indicates  $T_{\text{OFFSET}}$  and one of four values can be selected. This field is meaningless if the ERASE\_SIZE and ERASE\_TIMEOUT fields are set to 0.

**Table 150. Erase offset field**

ERASE_OFFSET	Value definition
0h	0 [sec]
1h	1 [sec]
2h	2 [sec]
3h	3 [sec]

**21.4.13 SD I/O mode****SD I/O interrupts**

To allow the SD I/O card to interrupt the MultiMediaCard/SD module, an interrupt function is available on a pin on the SD interface. Pin 8, used as SDIO\_D1 when operating in the 4-bit SD mode, signals the cards interrupt to the MultiMediaCard/SD module. The use of the interrupt is optional for each card or function within a card. The SD I/O interrupt is level-sensitive, which means that the interrupt line must be held active (low) until it is either recognized and acted upon by the MultiMediaCard/SD module or deasserted due to the end of the interrupt period. After the MultiMediaCard/SD module has serviced the interrupt, the interrupt status bit is cleared via an I/O write to the appropriate bit in the SD I/O card's internal registers. The interrupt output of all SD I/O cards is active low and the MultiMediaCard/SD module provides pull-up resistors on all data lines (SDIO\_D[3:0]). The MultiMediaCard/SD module samples the level of pin 8 (SDIO\_D/IRQ) into the interrupt detector only during the interrupt period. At all other times, the MultiMediaCard/SD module ignores this value.

The interrupt period is applicable for both memory and I/O operations. The definition of the interrupt period for operations with single blocks is different from the definition for multiple-block data transfers.

**SD I/O suspend and resume**

Within a multifunction SD I/O or a card with both I/O and memory functions, there are multiple devices (I/O and memory) that share access to the MMC/SD bus. To share access to the MMC/SD module among multiple devices, SD I/O and combo cards optionally implement the concept of suspend/resume. When a card supports suspend/resume, the MMC/SD module can temporarily halt a data transfer operation to one function or memory (suspend) to free the bus for a higher-priority transfer to a different function or memory. After this higher-priority transfer is complete, the original transfer is resumed (restarted) where it left off. Support of suspend/resume is optional on a per-card basis. To perform the

suspend/resume operation on the MMC/SD bus, the MMC/SD module performs the following steps:

1. Determines the function currently using the SDIO\_D [3:0] line(s)
2. Requests the lower-priority or slower transaction to suspend
3. Waits for the transaction suspension to complete
4. Begins the higher-priority transaction
5. Waits for the completion of the higher priority transaction
6. Restores the suspended transaction

### SD I/O ReadWait

The optional ReadWait (RW) operation is defined only for the SD 1-bit and 4-bit modes. The ReadWait operation allows the MMC/SD module to signal a card that it is reading multiple registers (IO\_RW\_EXTENDED, CMD53) to temporarily stall the data transfer while allowing the MMC/SD module to send commands to any function within the SD I/O device. To determine when a card supports the ReadWait protocol, the MMC/SD module must test capability bits in the internal card registers. The timing for ReadWait is based on the interrupt period.

## 21.4.14 Commands and responses

### Application-specific and general commands

The SD card host module system is designed to provide a standard interface for a variety of applications types. In this environment, there is a need for specific customer/application features. To implement these features, two types of generic commands are defined in the standard: application-specific commands (ACMD) and general commands (GEN\_CMD).

When the card receives the APP\_CMD (CMD55) command, the card expects the next command to be an application-specific command. ACMDs have the same structure as regular MultiMediaCard commands and can have the same CMD number. The card recognizes it as ACMD because it appears after APP\_CMD (CMD55). When the command immediately following the APP\_CMD (CMD55) is not a defined application-specific command, the standard command is used. For example, when the card has a definition for SD\_STATUS (ACMD13), and receives CMD13 immediately following APP\_CMD (CMD55), this is interpreted as SD\_STATUS (ACMD13). However, when the card receives CMD7 immediately following APP\_CMD (CMD55) and the card does not have a definition for ACMD7, this is interpreted as the standard (SELECT/DESELECT\_CARD) CMD7.

To use one of the manufacturer-specific ACMDs the SD card Host must perform the following steps:

1. Send APP\_CMD (CMD55)  
The card responds to the MultiMediaCard/SD module, indicating that the APP\_CMD bit is set and an ACMD is now expected.
2. Send the required ACMD  
The card responds to the MultiMediaCard/SD module, indicating that the APP\_CMD bit is set and that the accepted command is interpreted as an ACMD. When a non-ACMD is sent, it is handled by the card as a normal MultiMediaCard command and the APP\_CMD bit in the card status register stays clear.

When an invalid command is sent (neither ACMD nor CMD) it is handled as a standard MultiMediaCard illegal command error.

The bus transaction for a GEN\_CMD is the same as the single-block read or write commands (WRITE\_BLOCK, CMD24 or READ\_SINGLE\_BLOCK, CMD17). In this case, the argument denotes the direction of the data transfer rather than the address, and the data block has vendor-specific format and meaning.

The card must be selected (in transfer state) before sending GEN\_CMD (CMD56). The data block size is defined by SET\_BLOCKLEN (CMD16). The response to GEN\_CMD (CMD56) is in R1b format.

### Command types

Both application-specific and general commands are divided into the four following types:

- **broadcast command (BC)**: sent to all cards; no responses returned.
- **broadcast command with response (BCR)**: sent to all cards; responses received from all cards simultaneously.
- **addressed (point-to-point) command (AC)**: sent to the card that is selected; does not include a data transfer on the SDIO\_D line(s).
- **addressed (point-to-point) data transfer command (ADTC)**: sent to the card that is selected; includes a data transfer on the SDIO\_D line(s).

### Command formats

See [Table 135 on page 532](#) for command formats.

### Commands for the MultiMediaCard/SD module

**Table 151. Block-oriented write commands**

CMD index	Type	Argument	Response format	Abbreviation	Description
CMD23	ac	[31:16] set to 0 [15:0] number of blocks	R1	SET_BLOCK_COUNT	Defines the number of blocks which are going to be transferred in the multiple-block read or write command that follows.
CMD24	adtc	[31:0] data address	R1	WRITE_BLOCK	Writes a block of the size selected by the SET_BLOCKLEN command.
CMD25	adtc	[31:0] data address	R1	WRITE_MULTIPLE_BLOCK	Continuously writes blocks of data until a STOP_TRANSMISSION follows or the requested number of blocks has been received.
CMD26	adtc	[31:0] stuff bits	R1	PROGRAM_CID	Programming of the card identification register. This command must be issued only once per card. The card contains hardware to prevent this operation after the first programming. Normally this command is reserved for manufacturer.
CMD27	adtc	[31:0] stuff bits	R1	PROGRAM_CSD	Programming of the programmable bits of the CSD.

Table 152. Block-oriented write protection commands

CMD index	Type	Argument	Response format	Abbreviation	Description
CMD28	ac	[31:0] data address	R1b	SET_WRITE_PROT	If the card has write protection features, this command sets the write protection bit of the addressed group. The properties of write protection are coded in the card-specific data (WP_GRP_SIZE).
CMD29	ac	[31:0] data address	R1b	CLR_WRITE_PROT	If the card provides write protection features, this command clears the write protection bit of the addressed group.
CMD30	adtc	[31:0] write protect data address	R1	SEND_WRITE_PROT	If the card provides write protection features, this command asks the card to send the status of the write protection bits.
CMD31	Reserved				

Table 153. Erase commands

CMD index	Type	Argument	Response format	Abbreviation	Description
CMD32 ... CMD34	Reserved. These command indexes cannot be used in order to maintain backward compatibility with older versions of the MultiMediaCard.				
CMD35	ac	[31:0] data address	R1	ERASE_GROUP_START	Sets the address of the first erase group within a range to be selected for erase.
CMD36	ac	[31:0] data address	R1	ERASE_GROUP_END	Sets the address of the last erase group within a continuous range to be selected for erase.
CMD37	Reserved. This command index cannot be used in order to maintain backward compatibility with older versions of the MultiMediaCards				
CMD38	ac	[31:0] stuff bits	R1	ERASE	Erases all previously selected write blocks.

Table 154. I/O mode commands

CMD index	Type	Argument	Response format	Abbreviation	Description
CMD39	ac	[31:16] RCA [15:15] register write flag [14:8] register address [7:0] register data	R4	FAST_IO	Used to write and read 8-bit (register) data fields. The command addresses a card and a register and provides the data for writing if the write flag is set. The R4 response contains data read from the addressed register. This command accesses application-dependent registers that are not defined in the MultiMediaCard standard.

Table 154. I/O mode commands (continued)

CMD index	Type	Argument	Response format	Abbreviation	Description
CMD40	bcr	[31:0] stuff bits	R5	GO_IRQ_STATE	Places the system in the interrupt mode.
CMD41	Reserved				

Table 155. Lock card

CMD index	Type	Argument	Response format	Abbreviation	Description
CMD42	adtc	[31:0] stuff bits	R1b	LOCK_UNLOCK	Sets/resets the password or locks/unlocks the card. The size of the data block is set by the SET_BLOCK_LEN command.
CMD43 ... CMD54	Reserved				

Table 156. Application-specific commands

CMD index	Type	Argument	Response format	Abbreviation	Description
CMD55	ac	[31:16] RCA [15:0] stuff bits	R1	APP_CMD	Indicates to the card that the next command bits is an application specific command rather than a standard command
CMD56	adtc	[31:1] stuff bits [0]: RD/WR			Used either to transfer a data block to the card or to get a data block from the card for general purpose/application-specific commands. The size of the data block shall be set by the SET_BLOCK_LEN command.
CMD57 ... CMD59	Reserved.				
CMD60 ... CMD63	Reserved for manufacturer.				

## 21.5 Response formats

All responses are sent via the MCCMD command line SDIO\_CMD. The response transmission always starts with the left bit of the bit string corresponding to the response code word. The code length depends on the response type.

A response always starts with a start bit (always 0), followed by the bit indicating the direction of transmission (card = 0). A value denoted by x in the tables below indicates a variable entry. All responses, except for the R3 response type, are protected by a CRC. Every command code word is terminated by the end bit (always 1).

There are five types of responses. Their formats are defined as follows:

### 21.5.1 R1 (normal response command)

Code length = 48 bits. The 45:40 bits indicate the index of the command to be responded to, this value being interpreted as a binary-coded number (between 0 and 63). The status of the card is coded in 32 bits.

**Table 157. R1 response**

Bit position	Width (bits)	Value	Description
47	1	0	Start bit
46	1	0	Transmission bit
[45:40]	6	X	Command index
[39:8]	32	X	Card status
[7:1]	7	X	CRC7
0	1	1	End bit

### 21.5.2 R1b

It is identical to R1 with an optional busy signal transmitted on the data line. The card may become busy after receiving these commands based on its state prior to the command reception.

### 21.5.3 R2 (CID, CSD register)

Code length = 136 bits. The contents of the CID register are sent as a response to the CMD2 and CMD10 commands. The contents of the CSD register are sent as a response to CMD9. Only the bits [127...1] of the CID and CSD are transferred, the reserved bit [0] of these registers is replaced by the end bit of the response. The card indicates that an erase is in progress by holding MCDAT low. The actual erase time may be quite long, and the host may issue CMD7 to deselect the card.

**Table 158. R2 response**

Bit position	Width (bits)	Value	Description
135	1	0	Start bit
134	1	0	Transmission bit
[133:128]	6	'111111'	Command index
[127:1]	127	X	Card status
0	1	1	End bit

### 21.5.4 R3 (OCR register)

Code length: 48 bits. The contents of the OCR register are sent as a response to CMD1. The level coding is as follows: restricted voltage windows = low, card busy = low.

**Table 159. R3 response**

Bit position	Width (bits)	Value	Description
47	1	0	Start bit
46	1	0	Transmission bit
[45:40]	6	'111111'	Reserved
[39:8]	32	X	OCR register
[7:1]	7	'1111111'	Reserved
0	1	1	End bit

### 21.5.5 R4 (Fast I/O)

Code length: 48 bits. The argument field contains the RCA of the addressed card, the register address to be read out or written to, and its content.

**Table 160. R4 response**

Bit position	Width (bits)	Value	Description	
47	1	0	Start bit	
46	1	0	Transmission bit	
[45:40]	6	'111111'	Reserved	
[39:8] Argument field	[31:16]	16	X	RCA
	[15:8]	8	X	register address
	[7:0]	8	X	read register contents
[7:1]	7	'1111111'	CRC7	
0	1	1	End bit	

### 21.5.6 R4b

For SD I/O only: an SDIO card receiving the CMD5 will respond with a unique SDIO response R4. The format is:

**Table 161. R4b response**

Bit position	Width (bits)	Value	Description	
47	1	0	Start bit	
46	1	0	Transmission bit	
[45:40]	6	x	Reserved	
[39:8] Argument field	39	16	X	Card is ready
	[38:36]	3	X	Number of I/O functions
	35	1	X	Present memory
	[34:32]	3	X	Stuff bits
	[31:8]	24	X	I/O ORC



**Table 161. R4b response (continued)**

Bit position	Width (bits)	Value	Description
[7:1]	7	X	Reserved
0	1	1	End bit

Once an SD I/O card has received a CMD5, the I/O portion of that card is enabled to respond normally to all further commands. This I/O enable of the function within the I/O card will remain set until a reset, power cycle or CMD52 with write to I/O reset is received by the card. Note that an SD memory-only card may respond to a CMD5. The proper response for a memory-only card would be *Present memory* = 1 and *Number of I/O functions* = 0. A memory-only card built to meet the SD Memory Card specification version 1.0 would detect the CMD5 as an illegal command and not respond. The I/O aware host will send CMD5. If the card responds with response R4, the host determines the card's configuration based on the data contained within the R4 response.

### 21.5.7 R5 (interrupt request)

Only for MultiMediaCard. Code length: 48 bits. If the response is generated by the host, the RCA field in the argument will be 0x0.

**Table 162. R5 response**

Bit position	Width (bits)	Value	Description
47	1	0	Start bit
46	1	0	Transmission bit
[45:40]	6	'111111'	CMD40
[39:8] Argument field	[31:16]	X	RCA [31:16] of winning card or of the host
	[15:0]	X	Not defined. May be used for IRQ data
[7:1]	7	X	CRC7
0	1	1	End bit

### 21.5.8 R6

Only for SD I/O. The normal response to CMD3 by a memory device. It is shown in [Table 163](#).

**Table 163. R6 response**

Bit position	Width (bits)	Value	Description
47	1	0	Start bit
46	1	0	Transmission bit
[45:40]	6	'101000'	CMD40

**Table 163. R6 response (continued)**

Bit position		Width (bits)	Value	Description
[39:8] Argument field	[31:16]	16	X	RCA [31:16] of winning card or of the host
	[15:0]	16	X	Not defined. May be used for IRQ data
[7:1]		7	X	CRC7
0		1	1	End bit

The card [23:8] status bits are changed when CMD3 is sent to an I/O-only card. In this case, the 16 bits of response are the SD I/O-only values:

- Bit [15] COM\_CRC\_ERROR
- Bit [14] ILLEGAL\_COMMAND
- Bit [13] ERROR
- Bits [12:0] Reserved

## 21.6 SDIO I/O card-specific operations

The following features are SD I/O-specific operations:

- SDIO read wait operation by SDIO\_D2 signalling
- SDIO read wait operation by stopping the clock
- SDIO suspend/resume operation (write and read suspend)
- SDIO interrupts

The SDIO supports these operations only if the SDIO\_DCTRL[11] bit is set, except for read suspend that does not need specific hardware implementation.

### 21.6.1 SDIO I/O read wait operation by SDIO\_D2 signalling

It is possible to start the readwait interval before the first block is received: when the data path is enabled (SDIO\_DCTRL[0] bit set), the SDIO-specific operation is enabled (SDIO\_DCTRL[11] bit set), read wait starts (SDIO\_DCTRL[10] = 0 and SDI\_DCTRL[8] = 1) and data direction is from card to SDIO (SDIO\_DCTRL[1] = 1), the DPSM directly moves from Idle to Readwait. In Readwait the DPSM drives SDIO\_D2 to 0 after 2 SDIO\_CK clock cycles. In this state, when you set the RWSTOP bit (SDIO\_DCTRL[9]), the DPSM remains in Wait for two more SDIO\_CK clock cycles to drive SDIO\_D2 to 1 for one clock cycle (in accordance with SDIO specification). The DPSM then starts waiting again until it receives data from the card. The DPSM will not start a readwait interval while receiving a block even if read wait start is set: the readwait interval will start after the CRC is received. The RWSTOP bit has to be cleared to start a new read wait operation. During the readwait interval, the SDIO can detect SDIO interrupts on SDIO\_D1.

### 21.6.2 SDIO read wait operation by stopping SDIO\_CK

If the SDIO card does not support the previous read wait method, the SDIO can perform a read wait by stopping SDIO\_CK (SDIO\_DCTRL is set just like in the method presented in [Section 21.6.1](#), but SDIO\_DCTRL[10] = 1): DPSM stops the clock two SDIO\_CK cycles after the end bit of the current received block and starts the clock again after the read wait start bit is set.

As SDIO\_CK is stopped, any command can be issued to the card. During a read/wait interval, the SDIO can detect SDIO interrupts on SDIO\_D1.

### 21.6.3 SDIO suspend/resume operation

While sending data to the card, the SDIO can suspend the write operation. the SDIO\_CMD[11] bit is set and indicates to the CPSM that the current command is a suspend command. The CPSM analyzes the response and when the ACK is received from the card (suspend accepted), it acknowledges the DPSM that goes Idle after receiving the CRC token of the current block.

The hardware does not save the number of the remaining block to be sent to complete the suspended operation (resume).

The write operation can be suspended by software, just by disabling the DPSM (SDIO\_DCTRL[0] =0) when the ACK of the suspend command is received from the card. The DPSM enters then the Idle state.

To suspend a read: the DPSM waits in the Wait\_r state as the function to be suspended sends a complete packet just before stopping the data transaction. The application continues reading RxFIFO until the FIFO is empty, and the DPSM goes Idle automatically.

### 21.6.4 SDIO interrupts

SDIO interrupts are detected on the SDIO\_D1 line once the SDIO\_DCTRL[11] bit is set.

## 21.7 CE-ATA specific operations

The following features are CE-ATA specific operations:

- sending the command completion signal disable to the CE-ATA device
- receiving the command completion signal from the CE-ATA device
- signaling the completion of the CE-ATA command to the CPU, using the status bit and/or interrupt.

The SDIO supports these operations only for the CE-ATA CMD61 command, that is, if SDIO\_CMD[14] is set.

### 21.7.1 Command completion signal disable

Command completion signal disable is sent 8 bit cycles after the reception of a **short** response if the 'enable CMD completion' bit, SDIO\_CMD[12], is not set and the 'not interrupt Enable' bit, SDIO\_CMD[13], is set.

The CPSM enters the Pend state, loading the command shift register with the disable sequence "00001" and, the command counter with 43. Eight cycles after, a trigger moves the CPSM to the Send state. When the command counter reaches 48, the CPSM becomes Idle as no response is awaited.

### 21.7.2 Command completion signal enable

If the 'enable CMD completion' bit SDIO\_CMD[12] is set and the 'not interrupt Enable' bit SDIO\_CMD[13] is set, the CPSM waits for the command completion signal in the Waitcpl state.

When '0' is received on the CMD line, the CPSM enters the Idle state. No new command can be sent for 7 bit cycles. Then, for the last 5 cycles (out of the 7) the CMD line is driven to '1' in push-pull mode.

### 21.7.3 CE-ATA interrupt

The command completion is signaled to the CPU by the status bit SDIO\_STA[23]. This static bit can be cleared with the clear bit SDIO\_ICR[23].

The SDIO\_STA[23] status bit can generate an interrupt on each interrupt line, depending on the mask bit SDIO\_MASKx[23].

### 21.7.4 Aborting CMD61

If the command completion disable signal has not been sent and CMD61 needs to be aborted, the command state machine must be disabled. It then becomes Idle, and the CMD12 command can be sent. No command completion disable signal is sent during the operation.

## 21.8 HW flow control

The HW flow control functionality is used to avoid FIFO underrun (TX mode) and overrun (RX mode) errors.

The behavior is to stop SDIO\_CK and freeze SDIO state machines. The data transfer is stalled while the FIFO is unable to transmit or receive data. Only state machines clocked by SDIOCLK are frozen, the AHB interface is still alive. The FIFO can thus be filled or emptied even if flow control is activated.

To enable HW flow control, the SDIO\_CLKCR[14] register bit must be set to 1. After reset Flow Control is disabled.

## 21.9 SDIO registers

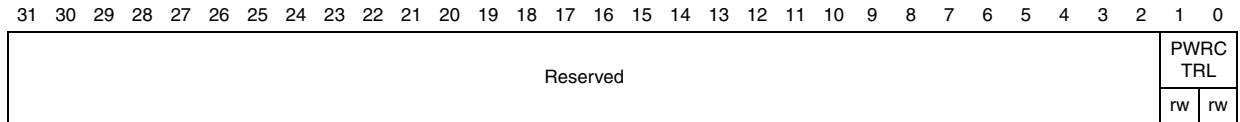
The device communicates to the system via 32-bit-wide control registers accessible via AHB.

The peripheral registers have to be accessed by words (32-bit).

### 21.9.1 SDIO power control register (SDIO\_POWER)

Address offset: 0x00

Reset value: 0x0000 0000



Bits 31:2 Reserved, always read as 0.

[1:0] **PWRCTRL**: Power supply control bits.

These bits are used to define the current functional state of the card clock:

00: Power-off: the clock to card is stopped.

01: Reserved

10: Reserved power-up

11: Power-on: the card is clocked.

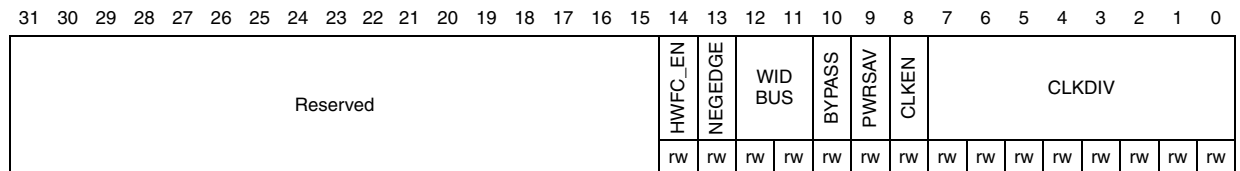
*Note:* After a data write, data cannot be written to this register for seven HCLK clock periods.

### 21.9.2 SDI clock control register (SDIO\_CLKCR)

Address offset: 0x04

Reset value: 0x0000 0000

The SDIO\_CLKCR register controls the SDIO\_CK output clock.



Bits 31:15 Reserved, always read as 0.

Bit 14 **HWFC\_EN**: HW Flow Control enable

0b: HW Flow Control is disabled

1b: HW Flow Control is enabled

When HW Flow Control is enabled, the meaning of the TXFIFOE and RXFIFOE interrupt signals, please see SDIO Status register definition in [Section 21.9.11](#).

Bit 13 **NEGEDGE**:SDIO\_CK dephasing selection bit

0b: SDIO\_CK generated on the rising edge of the master clock SDIOCLK

1b: SDIO\_CK generated on the falling edge of the master clock SDIOCLK

Bits 12:11 **WIDBUS**: Wide bus mode enable bit

00: Default bus mode: SDIO\_D0 used

01: 4-wide bus mode: SDIO\_D[3:0] used

10: 8-wide bus mode: SDIO\_D[7:0] used

- Bit 10 **BYPASS**: Clock divider bypass enable bit
  - 0: Disable bypass: SDIOCLK is divided according to the CLKDIV value before driving the SDIO\_CK output signal.
  - 1: Enable bypass: SDIOCLK directly drives the SDIO\_CK output signal.
- Bit 9 **PWRSABV**: Power saving configuration bit
  - For power saving, the SDIO\_CK clock output can be disabled when the bus is idle by setting PWRSABV:
  - 0: SDIO\_CK clock is always enabled
  - 1: SDIO\_CK is only enabled when the bus is active
- Bit 8 **CLKEN**: Clock enable bit
  - 0: SDIO\_CK is disabled
  - 1: SDIO\_CK is enabled
- Bits 7:0 **CLKDIV**: Clock divide factor
  - This field defines the divide factor between the input clock (SDIOCLK) and the output clock (SDIO\_CK):  $SDIO\_CK\ frequency = SDIOCLK / [CLKDIV + 2]$ .

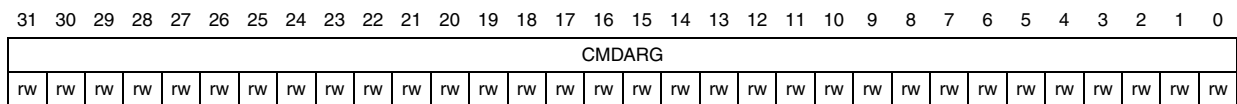
- Note:*
- 1 While the SD/SDIO card or MultiMediaCard is in identification mode, the SDIO\_CK frequency must be less than 400 kHz.
  - 2 The clock frequency can be changed to the maximum card bus frequency when relative card addresses are assigned to all cards.
  - 3 After a data write, data cannot be written to this register for seven HCLK clock periods. SDIO\_CK can also be stopped during the read wait interval for SD I/O cards: in this case the SDIO\_CLKCR register does not control SDIO\_CK.

### 21.9.3 SDIO argument register (SDIO\_ARG)

Address offset: 0x08

Reset value: 0x0000 0000

The SDIO\_ARG register contains a 32-bit command argument, which is sent to a card as part of a command message.



- Bits 31:0 **CMDARG**: Command argument
  - Command argument sent to a card as part of a command message. If a command contains an argument, it must be loaded into this register before writing a command to the command register.



### 21.9.4 SDIO command register (SDIO\_CMD)

Address offset: 0x0C

Reset value: 0x0000 0000

The SDIO\_CMD register contains the command index and command type bits. The command index is sent to a card as part of a command message. The command type bits control the command path state machine (CPSM).

31	30	29	28	27	26	25	24	23	22	21	20	19	18	17	16	15	14	13	12	11	10	9	8	7	6	5	4	3	2	1	0														
Reserved																	CE-ATACMD	nIEN	ENCMDcompl	SDIOSuspend	CPSMEN	WAITPEND	WAITINT	WAITRESP	CMDINDEX																				
																	rw	rw	rw	rw	rw	rw	rw	rw	rw	rw	rw	rw	rw	rw	rw	rw	rw	rw	rw	rw	rw	rw	rw	rw	rw	rw	rw	rw	rw

Bits 31:15 Reserved, always read as 0.

Bit 14 **ATACMD**: CE-ATA command

If ATACMD is set, the CPSM transfers CMD61.

Bit 13 **nIEN**: not Interrupt Enable

if this bit is 0, interrupts in the CE-ATA device are enabled.

Bit 12 **ENCMDcompl**: Enable CMD completion

If this bit is set, the command completion signal is enabled.

Bit 11 **SDIOSuspend**: SD I/O suspend command

If this bit is set, the command to be sent is a suspend command (to be used only with SDIO card).

Bit 10 **CPSMEN**: Command path state machine (CPSM) Enable bit

If this bit is set, the CPSM is enabled.

Bit 9 **WAITPEND**: CPSM Waits for ends of data transfer (CmdPend internal signal).

If this bit is set, the CPSM waits for the end of data transfer before it starts sending a command.

Bit 8 **WAITINT**: CPSM waits for interrupt request

If this bit is set, the CPSM disables command timeout and waits for an interrupt request.

Bits 7:6 **WAITRESP**: Wait for response bits

They are used to configure whether the CPSM is to wait for a response, and if yes, which kind of response.

00: No response, expect CMDSENT flag

01: Short response, expect CMDREND or CCRCFAIL flag

10: No response, expect CMDSENT flag

11: Long response, expect CMDREND or CCRCFAIL flag

Bit 5:0 **CMDINDEX**: Command index

The command index is sent to the card as part of a command message.

*Note:* 1 After a data write, data cannot be written to this register for seven HCLK clock periods.

2 MultiMediaCards can send two kinds of response: short responses, 48 bits long, or long responses, 136 bits long. SD card and SD I/O card can send only short responses, the

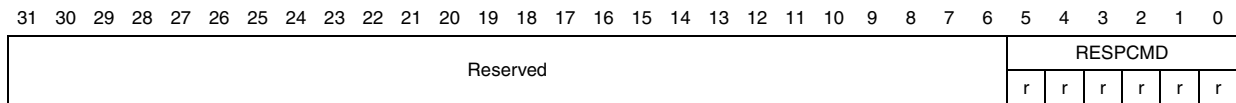
argument can vary according to the type of response: the software will distinguish the type of response according to the sent command. CE-ATA devices send only short responses.

### 21.9.5 SDIO command response register (SDIO\_RESPCMD)

Address offset: 0x10

Reset value: 0x0000 0000

The SDIO\_RESPCMD register contains the command index field of the last command response received. If the command response transmission does not contain the command index field (long or OCR response), the RESPCMD field is unknown, although it must contain 11111b (the value of the reserved field from the response).



Bits 31:6 Reserved, always read as 0.

Bits 5:0 **RESPCMD**: Response command index

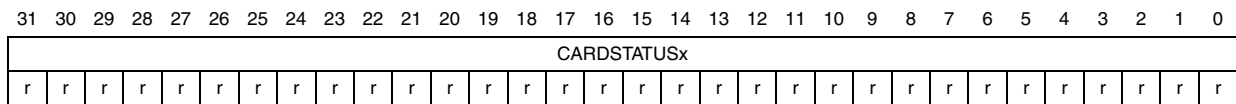
Read-only bit field. Contains the command index of the last command response received.

### 21.9.6 SDIO response 1..4 register (SDIO\_RESPx)

Address offset: (0x10 + (4 × x)); x = 1..4

Reset value: 0x0000 0000

The SDIO\_RESP1/2/3/4 registers contain the status of a card, which is part of the received response.



Bits 31:0 **CARDSTATUSx**: see [Table 164](#).

The Card Status size is 32 or 127 bits, depending on the response type.

**Table 164. Response type and SDIO\_RESPx registers**

Register	Short response	Long response
SDIO_RESP1	Card Status[31:0]	Card Status [127:96]
SDIO_RESP2	Unused	Card Status [95:64]
SDIO_RESP3	Unused	Card Status [63:32]
SDIO_RESP4	Unused	Card Status [31:1]0b

The most significant bit of the card status is received first. The SDIO\_RESP3 register LSB is always 0b.



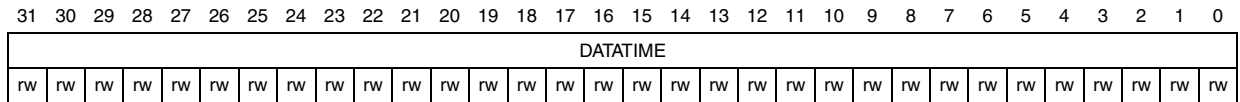
### 21.9.7 SDIO data timer register (SDIO\_DTIMER)

Address offset: 0x24

Reset value: 0x0000 0000

The SDIO\_DTIMER register contains the data timeout period, in card bus clock periods.

A counter loads the value from the SDIO\_DTIMER register, and starts decrementing when the data path state machine (DPSM) enters the Wait\_R or Busy state. If the timer reaches 0 while the DPSM is in either of these states, the timeout status flag is set.



Bits 31:0 **DATATIME**: Data timeout period  
 Data timeout period expressed in card bus clock periods.

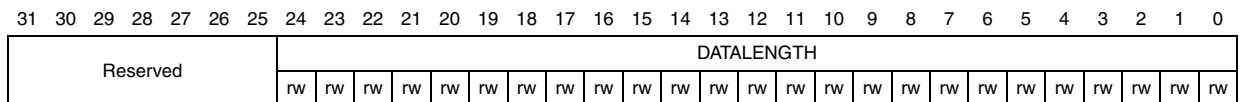
*Note:* A data transfer must be written to the data timer register and the data length register before being written to the data control register.

### 21.9.8 SDIO data length register (SDIO\_DLEN)

Address offset: 0x28

Reset value: 0x0000 0000

The SDIO\_DLEN register contains the number of data bytes to be transferred. The value is loaded into the data counter when data transfer starts.



Bits 31:25 Reserved, always read as 0.  
 Bits 24:0 **DATALENGTH**: Data length value  
 Number of data bytes to be transferred.

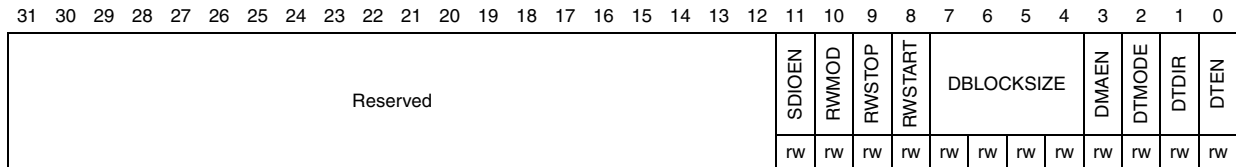
*Note:* For a block data transfer, the value in the data length register must be a multiple of the block size (see SDIO\_DCTRL). A data transfer must be written to the data timer register and the data length register before being written to the data control register.

### 21.9.9 SDIO data control register (SDIO\_DCTRL)

Address offset: 0x2C

Reset value: 0x0000 0000

The SDIO\_DCTRL register control the data path state machine (DPSM).



Bits 31:12 Reserved, always read as 0.

Bit 11 **SDIOEN**: SD I/O enable functions

If this bit is set, the DPSM performs an SD I/O-card-specific operation.

Bit 10 **RWMOD**: Read wait mode

0: Read Wait control stopping SDIO\_D2

1: Read Wait control using SDIO\_CK

Bit 9 **RWSTOP**: Read wait stop

0: Read wait in progress if RWSTART bit is set

1: Enable for read wait stop if RWSTART bit is set

Bit 8 **RWSTART**: Read wait start

If this bit is set, read wait operation starts.

Bits 7:4 **DBLOCKSIZE**: Data block size

Define the data block length when the block data transfer mode is selected:

0000: (0 decimal) lock length =  $2^0$  = 1 byte

0001: (1 decimal) lock length =  $2^1$  = 2 bytes

0010: (2 decimal) lock length =  $2^2$  = 4 bytes

0011: (3 decimal) lock length =  $2^3$  = 8 bytes

0100: (4 decimal) lock length =  $2^4$  = 16 bytes

0101: (5 decimal) lock length =  $2^5$  = 32 bytes

0110: (6 decimal) lock length =  $2^6$  = 64 bytes

0111: (7 decimal) lock length =  $2^7$  = 128 bytes

1000: (8 decimal) lock length =  $2^8$  = 256 bytes

1001: (9 decimal) lock length =  $2^9$  = 512 bytes

1010: (10 decimal) lock length =  $2^{10}$  = 1024 bytes

1011: (11 decimal) lock length =  $2^{11}$  = 2048 bytes

1100: (12 decimal) lock length =  $2^{12}$  = 4096 bytes

1101: (13 decimal) lock length =  $2^{13}$  = 8192 bytes

1110: (14 decimal) lock length =  $2^{14}$  = 16384 bytes

1111: (15 decimal) reserved

Bit 3 **DMAEN**: DMA enable bit

0: DMA disabled.

1: DMA enabled.

Bit 2 **DTMODE**: Data transfer mode selection 1: Stream or SDIO multibyte data transfer.  
 0: Block data transfer  
 1: Stream or SDIO multibyte data transfer on STM32F10xxx XL-density devices.  
 Stream data transfer on STM32F10xxx high-density devices.

Bit 1 **DTDIR**: Data transfer direction selection  
 0: From controller to card.  
 1: From card to controller.

[0] **DTEN**: Data transfer enabled bit  
 Data transfer starts if 1b is written to the DTEN bit. Depending on the direction bit, DTDIR, the DPSM moves to the Wait\_S, Wait\_R state or Readwait if RW Start is set immediately at the beginning of the transfer. It is not necessary to clear the enable bit after the end of a data transfer but the SDIO\_DCTRL must be updated to enable a new data transfer

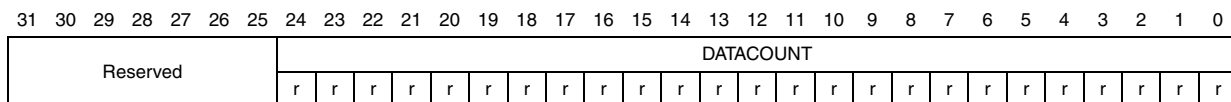
*Note:* After a data write, data cannot be written to this register for seven HCLK clock periods.

### 21.9.10 SDIO data counter register (SDIO\_DCOUNT)

Address offset: 0x30

Reset value: 0x0000 0000

The SDIO\_DCOUNT register loads the value from the data length register (see SDIO\_DLEN) when the DPSM moves from the Idle state to the Wait\_R or Wait\_S state. As data is transferred, the counter decrements the value until it reaches 0. The DPSM then moves to the Idle state and the data status end flag, DATAEND, is set.



Bits 31:25 Reserved, always read as 0.

Bits 24:0 **DATACOUNT**: Data count value  
 When this bit is read, the number of remaining data bytes to be transferred is returned. Write has no effect.

*Note:* This register should be read only when the data transfer is complete.

### 21.9.11 SDIO status register (SDIO\_STA)

Address offset: 0x34

Reset value: 0x0000 0000

The SDIO\_STA register is a read-only register. It contains two types of flag:

- Static flags (bits [23:22,10:0]): these bits remain asserted until they are cleared by writing to the SDIO Interrupt Clear register (see SDIO\_ICR)
- Dynamic flags (bits [21:11]): these bits change state depending on the state of the underlying logic (for example, FIFO full and empty flags are asserted and deasserted as data while written to the FIFO)

31	30	29	28	27	26	25	24	23	22	21	20	19	18	17	16	15	14	13	12	11	10	9	8	7	6	5	4	3	2	1	0		
Reserved								CEATAEND	SDIOIT	RXDAVL	TXDAVL	RXFIFOE	TXFIFOE	RXFIFO	TXFIFO	RXFIFOH	TXFIFOHE	RXACT	TXACT	CMDACT	DBCKEND	STBITERR	DATAEND	CMDSENT	CMDREND	RXOVERR	TXUNDERR	DTIMEOUT	CTIMEOUT	DCRCFAIL	CCRCFAIL		
Res.								r	r	r	r	r	r	r	r	r	r	r	r	r	r	r	r	r	r	r	r	r	r	r	r	r	r

Bits 31:24 Reserved, always read as 0.

Bit 23 **CEATAEND**: CE-ATA command completion signal received for CMD61

Bit 22 **SDIOIT**: SDIO interrupt received

Bit 21 **RXDAVL**: Data available in receive FIFO

Bit 20 **TXDAVL**: Data available in transmit FIFO

Bit 19 **RXFIFOE**: Receive FIFO empty

Bit 18 **TXFIFOE**: Transmit FIFO empty

When HW Flow Control is enabled, TXFIFOE signals becomes activated when the FIFO contains 2 words.

Bit 17 **RXFIFO**: Receive FIFO full

When HW Flow Control is enabled, RXFIFO signals becomes activated 2 words before the FIFO is full.

Bit 16 **TXFIFO**: Transmit FIFO full

Bit 15 **RXFIFOH**: Receive FIFO half full: there are at least 8 words in the FIFO

Bit 14 **TXFIFOHE**: Transmit FIFO half empty: at least 8 words can be written into the FIFO

Bit 13 **RXACT**: Data receive in progress

Bit 12 **TXACT**: Data transmit in progress

Bit 11 **CMDACT**: Command transfer in progress

Bit 10 **DBCKEND**: Data block sent/received (CRC check passed)

Bit 9 **STBITERR**: Start bit not detected on all data signals in wide bus mode

Bit 8 **DATAEND**: Data end (data counter, SDIDCOUNT, is zero)

Bit 7 **CMDSENT**: Command sent (no response required)

Bit 6 **CMDREND**: Command response received (CRC check passed)

Bit 5 **RXOVERR**: Received FIFO overrun error

- Bit 4 **TXUNDERR**: Transmit FIFO underrun error
- Bit 3 **DTIMEOUT**: Data timeout
- Bit 2 **CTIMEOUT**: Command response timeout  
The Command TimeOut period has a fixed value of 64 SDIO\_CK clock periods.
- Bit 1 **DCRCFAIL**: Data block sent/received (CRC check failed)
- Bit 0 **CCRCFAIL**: Command response received (CRC check failed)

### 21.9.12 SDIO interrupt clear register (SDIO\_ICR)

Address offset: 0x38

Reset value: 0x0000 0000

The SDIO\_ICR register is a write-only register. Writing a bit with 1b clears the corresponding bit in the SDIO\_STA Status register.

31	30	29	28	27	26	25	24	23	22	21	20	19	18	17	16	15	14	13	12	11	10	9	8	7	6	5	4	3	2	1	0				
Reserved								CEATAENDC	SDIOITC	Reserved											DBCKENDC	STBITERRC	DATAENDC	CMDSENTC	CMDREND	RXOVERRC	TXUNDERRC	DTIMEOUTC	CTIMEOUTC	DCRCFAILC	CCRCFAILC				
								rw	rw												rw	rw	rw	rw	rw	rw	rw	rw	rw	rw	rw	rw	rw	rw	rw

- Bits 31:24 Reserved, always read as 0.
- Bit 23 **CEATAENDC**: CEATAEND flag clear bit  
Set by software to clear the CEATAEND flag.  
0: CEATAEND not cleared  
1: CEATAEND cleared
- Bit 22 **SDIOITC**: SDIOIT flag clear bit  
Set by software to clear the SDIOIT flag.  
0: SDIOIT not cleared  
1: SDIOIT cleared
- Bits 21:11 Reserved, always read as 0.
- Bit 10 **DBCKENDC**: DBCKEND flag clear bit  
Set by software to clear the DBCKEND flag.  
0: DBCKEND not cleared  
1: DBCKEND cleared
- Bit 9 **STBITERRC**: STBITERR flag clear bit  
Set by software to clear the STBITERR flag.  
0: STBITERR not cleared  
1: STBITERR cleared
- Bit 8 **DATAENDC**: DATAEND flag clear bit  
Set by software to clear the DATAEND flag.  
0: DATAEND not cleared  
1: DATAEND cleared

- Bit 7 **CMDSENTC**: CMDSENT flag clear bit  
Set by software to clear the CMDSENT flag.  
0: CMDSENT not cleared  
1: CMDSENT cleared
- Bit 6 **CMDREND C**: CMDREND flag clear bit  
Set by software to clear the CMDREND flag.  
0: CMDREND not cleared  
1: CMDREND cleared
- Bit 5 **RXOVERR C**: RXOVERR flag clear bit  
Set by software to clear the RXOVERR flag.  
0: RXOVERR not cleared  
1: RXOVERR cleared
- Bit 4 **TXUNDERR C**: TXUNDERR flag clear bit  
Set by software to clear TXUNDERR flag.  
0: TXUNDERR not cleared  
1: TXUNDERR cleared
- Bit 3 **DTIMEOUT C**: DTIMEOUT flag clear bit  
Set by software to clear the DTIMEOUT flag.  
0: DTIMEOUT not cleared  
1: DTIMEOUT cleared
- Bit 2 **CTIMEOUT C**: CTIMEOUT flag clear bit  
Set by software to clear the CTIMEOUT flag.  
0: CTIMEOUT not cleared  
1: CTIMEOUT cleared
- Bit 1 **DCRCFAIL C**: DCRCFAIL flag clear bit  
Set by software to clear the DCRCFAIL flag.  
0: DCRCFAIL not cleared  
1: DCRCFAIL cleared
- Bit 0 **CCRCFAIL C**: CCRCFAIL flag clear bit  
Set by software to clear the CCRCFAIL flag.  
0: CCRCFAIL not cleared  
1: CCRCFAIL cleared

### 21.9.13 SDIO mask register (SDIO\_MASK)

Address offset: 0x3C

Reset value: 0x0000 0000

The interrupt mask register determines which status flags generate an interrupt request by setting the corresponding bit to 1b.

31	30	29	28	27	26	25	24	23	22	21	20	19	18	17	16	15	14	13	12	11	10	9	8	7	6	5	4	3	2	1	0
Reserved								CEATAENDIE	SDIOITIE	RXDAVLIE	TXDAVLIE	RXFIFOEIE	TXFIFOEIE	RXFIFOEIE	TXFIFOEIE	RXFIFOEIE	TXFIFOEIE	RXACTIE	TXACTIE	CMDACTIE	DBCKENDIE	STBITERRIE	DATAENDIE	CMDSENTIE	CMDRENDIE	RXOVERRIE	TXUNDERRIE	DTIMEOUTIE	CTIMEOUTIE	DCRCFAILIE	CCRCFAILIE
								rw	rw	rw	rw	rw	rw	rw	rw	rw	rw	rw	rw	rw	rw	rw	rw	rw	rw	rw	rw	rw	rw	rw	

Bits 31:24 Reserved, always read as 0.

- Bit 23 CEATAENDIE:** CE-ATA command completion signal received interrupt enable  
 Set and cleared by software to enable/disable the interrupt generated when receiving the CE-ATA command completion signal.  
 0: CE-ATA command completion signal received interrupt disabled  
 1: CE-ATA command completion signal received interrupt enabled
- Bit 22 SDIOITIE:** SDIO mode interrupt received interrupt enable  
 Set and cleared by software to enable/disable the interrupt generated when receiving the SDIO mode interrupt.  
 0: SDIO Mode Interrupt Received interrupt disabled  
 1: SDIO Mode Interrupt Received interrupt enabled
- Bit 21 RXDAVLIE:** Data available in Rx FIFO interrupt enable  
 Set and cleared by software to enable/disable the interrupt generated by the presence of data available in Rx FIFO.  
 0: Data available in Rx FIFO interrupt disabled  
 1: Data available in Rx FIFO interrupt enabled
- Bit 20 TXDAVLIE:** Data available in Tx FIFO interrupt enable  
 Set and cleared by software to enable/disable the interrupt generated by the presence of data available in Tx FIFO.  
 0: Data available in Tx FIFO interrupt disabled  
 1: Data available in Tx FIFO interrupt enabled
- Bit 19 RXFIFOEIE:** Rx FIFO empty interrupt enable  
 Set and cleared by software to enable/disable interrupt caused by Rx FIFO empty.  
 0: Rx FIFO empty interrupt disabled  
 1: Rx FIFO empty interrupt enabled
- Bit 18 TXFIFOEIE:** Tx FIFO empty interrupt enable  
 Set and cleared by software to enable/disable interrupt caused by Tx FIFO empty.  
 0: Tx FIFO empty interrupt disabled  
 1: Tx FIFO empty interrupt enabled
- Bit 17 RXFIOFIE:** Rx FIFO full interrupt enable  
 Set and cleared by software to enable/disable interrupt caused by Rx FIFO full.  
 0: Rx FIFO full interrupt disabled  
 1: Rx FIFO full interrupt enabled

- Bit 16 **TXFIFOIE**: Tx FIFO full interrupt enable  
Set and cleared by software to enable/disable interrupt caused by Tx FIFO full.  
0: Tx FIFO full interrupt disabled  
1: Tx FIFO full interrupt enabled
- Bit 15 **RXFIFOHFIE**: Rx FIFO half full interrupt enable  
Set and cleared by software to enable/disable interrupt caused by Rx FIFO half full.  
0: Rx FIFO half full interrupt disabled  
1: Rx FIFO half full interrupt enabled
- Bit 14 **TXFIFOHEIE**: Tx FIFO half empty interrupt enable  
Set and cleared by software to enable/disable interrupt caused by Tx FIFO half empty.  
0: Tx FIFO half empty interrupt disabled  
1: Tx FIFO half empty interrupt enabled
- Bit 13 **RXACTIE**: Data receive acting interrupt enable  
Set and cleared by software to enable/disable interrupt caused by data being received (data receive acting).  
0: Data receive acting interrupt disabled  
1: Data receive acting interrupt enabled
- Bit 12 **TXACTIE**: Data transmit acting interrupt enable  
Set and cleared by software to enable/disable interrupt caused by data being transferred (data transmit acting).  
0: Data transmit acting interrupt disabled  
1: Data transmit acting interrupt enabled
- Bit 11 **CMDACTIE**: Command acting interrupt enable  
Set and cleared by software to enable/disable interrupt caused by a command being transferred (command acting).  
0: Command acting interrupt disabled  
1: Command acting interrupt enabled
- Bit 10 **DBCKENDIE**: Data block end interrupt enable  
Set and cleared by software to enable/disable interrupt caused by data block end.  
0: Data block end interrupt disabled  
1: Data block end interrupt enabled
- Bit 9 **STBITERRIE**: Start bit error interrupt enable  
Set and cleared by software to enable/disable interrupt caused by start bit error.  
0: Start bit error interrupt disabled  
1: Start bit error interrupt enabled
- Bit 8 **DATAENDIE**: Data end interrupt enable  
Set and cleared by software to enable/disable interrupt caused by data end.  
0: Data end interrupt disabled  
1: Data end interrupt enabled
- Bit 7 **CMDSSENTIE**: Command sent interrupt enable  
Set and cleared by software to enable/disable interrupt caused by sending command.  
0: Command sent interrupt disabled  
1: Command sent interrupt enabled



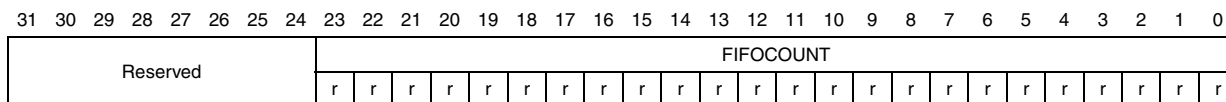
- Bit 6 **CMDRENDIE**: Command response received interrupt enable  
 Set and cleared by software to enable/disable interrupt caused by receiving command response.  
 0: Command response received interrupt disabled  
 1: command Response Received interrupt enabled
- Bit 5 **RXOVERRIE**: Rx FIFO overrun error interrupt enable  
 Set and cleared by software to enable/disable interrupt caused by Rx FIFO overrun error.  
 0: Rx FIFO overrun error interrupt disabled  
 1: Rx FIFO overrun error interrupt enabled
- Bit 4 **TXUNDERRIE**: Tx FIFO underrun error interrupt enable  
 Set and cleared by software to enable/disable interrupt caused by Tx FIFO underrun error.  
 0: Tx FIFO underrun error interrupt disabled  
 1: Tx FIFO underrun error interrupt enabled
- Bit 3 **DTIMEOUTIE**: Data timeout interrupt enable  
 Set and cleared by software to enable/disable interrupt caused by data timeout.  
 0: Data timeout interrupt disabled  
 1: Data timeout interrupt enabled
- Bit 2 **CTIMEOUTIE**: Command timeout interrupt enable  
 Set and cleared by software to enable/disable interrupt caused by command timeout.  
 0: Command timeout interrupt disabled  
 1: Command timeout interrupt enabled
- Bit 1 **DCRCFAILIE**: Data CRC fail interrupt enable  
 Set and cleared by software to enable/disable interrupt caused by data CRC failure.  
 0: Data CRC fail interrupt disabled  
 1: Data CRC fail interrupt enabled
- Bit 0 **CCRCFAILIE**: Command CRC fail interrupt enable  
 Set and cleared by software to enable/disable interrupt caused by command CRC failure.  
 0: Command CRC fail interrupt disabled  
 1: Command CRC fail interrupt enabled

### 21.9.14 SDIO FIFO counter register (SDIO\_FIFOCNT)

Address offset: 0x48

Reset value: 0x0000 0000

The SDIO\_FIFOCNT register contains the remaining number of words to be written to or read from the FIFO. The FIFO counter loads the value from the data length register (see SDIO\_DLEN) when the data transfer enable bit, DTEN, is set in the data control register (SDIO\_DCTRL register) and the DPSM is at the Idle state. If the data length is not word-aligned (multiple of 4), the remaining 1 to 3 bytes are regarded as a word.



Bits 31:24 Reserved, always read as 0.

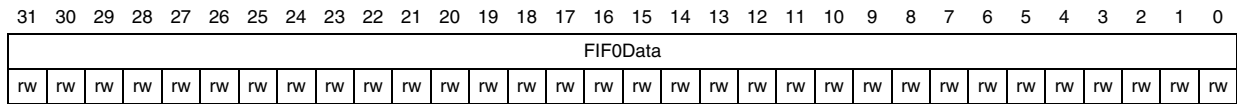
Bits 23:0 **FIFOCOUNT**: Remaining number of words to be written to or read from the FIFO.

### 21.9.15 SDIO data FIFO register (SDIO\_FIFO)

Address offset: 0x80

Reset value: 0x0000 0000

The receive and transmit FIFOs can be read or written as 32-bit wide registers. The FIFOs contain 32 entries on 32 sequential addresses. This allows the CPU to use its load and store multiple operands to read from/write to the FIFO.



bits 31:0 **FIFOData**: Receive and transmit FIFO data

The FIFO data occupies 32 entries of 32-bit words, from address: SDIO base + 0x080 to SDIO base + 0xFC.

### 21.9.16 SDIO register map

The following table summarizes the SDIO registers.

Table 165. SDIO register map

Offset	Register	31	30	29	28	27	26	25	24	23	22	21	20	19	18	17	16	15	14	13	12	11	10	9	8	7	6	5	4	3	2	1	0		
0x00	SDIO_POWER	Reserved																PWRCTRL																	
0x04	SDIO_CLKCR	Reserved																HWFC_LEN	NEGEDGE	WIDBUS	BYPASS	PWRSAV	CLKEN	CLKDIV											
0x08	SDIO_ARG	CMDARG																																	
0x0C	SDIO_CMD	Reserved																CE-ATACMD	nIEN	ENCMDcompl	SDIOSuspend	CPSMEN	WAITPEND	WAITINT	WAITRESP	CMDINDEX									
0x10	SDIO_RESPCMD	Reserved																								RESPCMD									
0x14	SDIO_RESP1	CARDSTATUS1																																	
0x18	SDIO_RESP2	CARDSTATUS2																																	
0x1C	SDIO_RESP3	CARDSTATUS3																																	
0x20	SDIO_RESP4	CARDSTATUS4																																	
0x24	SDIO_DTIMER	DATATIME																																	
0x28	SDIO_DLEN	Reserved						DATALENGTH																											
0x2C	SDIO_DCTRL	Reserved																SDIOEN	RWMOD	RWSTOP	RWSTART	DBLOCKSIZE				DMAEN	DTMODE	DTDIR	DTEN						
0x30	SDIO_DCOUNT	Reserved						DATACOUNT																											
0x34	SDIO_STA	Reserved						CEATAEND	SDIOIT	RXDAVL	TXDAVL	RXFIFOE	TXFIFOE	RXFIFO	TXFIFO	RXFIFOH	TXFIFOHE	RXACT	TXACT	CMDACT	DBCKEND	STBITERR	DATAEND	CMDSENT	CMDREND	RXOVERR	TXUNDERR	DTIMEOUT	CTIMEOUT	DCRCFAIL	CCRCFAIL				



Table 165. SDIO register map (continued)

Offset	Register	31	30	29	28	27	26	25	24	23	22	21	20	19	18	17	16	15	14	13	12	11	10	9	8	7	6	5	4	3	2	1	0
0x38	SDIO_ICR	Reserved								CEATAENDC	SDIOITC	Reserved										DBCKENDC	STBITERRC	DATAENDC	CMDSENTC	CMDPRENDIC	RXOVERRRC	TXUNDERRRC	DTIMEOUTC	CTIMEOUTC	DCRCFALC	CCRCFALC	
0x3C	SDIO_MASK	Reserved								CEATAENDIE	SDIOITIE	RXDAVLIE	TXDAVLIE	RXFIOEIE	TXFIOEIE	RXFIOFIE	TXFIOFIE	RXFIOHFIE	TXFIOHEIE	RXACTIE	TXACTIE	CMDACTIE	DBCKENDIE	STBITERRIE	DATAENDIE	CMDSENTIE	CMDPRENDIE	RXOVERRIE	TXUNDERRIE	DTIMEOUTIE	CTIMEOUTIE	DCRCFALIE	CCRCFALIE
0x48	SDIO_FIFOCNT	Reserved								FIFOCOUNT																							
0x80	SDIO_FIFO	FIFOData																															

Note: Refer to [Table 1 on page 44](#) for the register boundary addresses.

## 22 Universal serial bus full-speed device interface (USB)

**Low-density devices** are STM32F101xx, STM32F102xx and STM32F103xx microcontrollers where the Flash memory density ranges between 16 and 32 Kbytes.

**Medium-density devices** are STM32F101xx, STM32F102xx and STM32F103xx microcontrollers where the Flash memory density ranges between 64 and 128 Kbytes.

**High-density devices** are STM32F101xx and STM32F103xx microcontrollers where the Flash memory density ranges between 256 and 512 Kbytes.

**XL-density devices** are STM32F101xx and STM32F103xx microcontrollers where the Flash memory density ranges between 768 Kbytes and 1 Mbyte.

**Connectivity line devices** are STM32F105xx and STM32F107xx microcontrollers.

This section applies to the STM32F103xx performance line and STM32F102xx USB access line families only.

### 22.1 USB introduction

The USB peripheral implements an interface between a full-speed USB 2.0 bus and the APB1 bus.

USB suspend/resume are supported which allows to stop the device clocks for low-power consumption.

### 22.2 USB main features

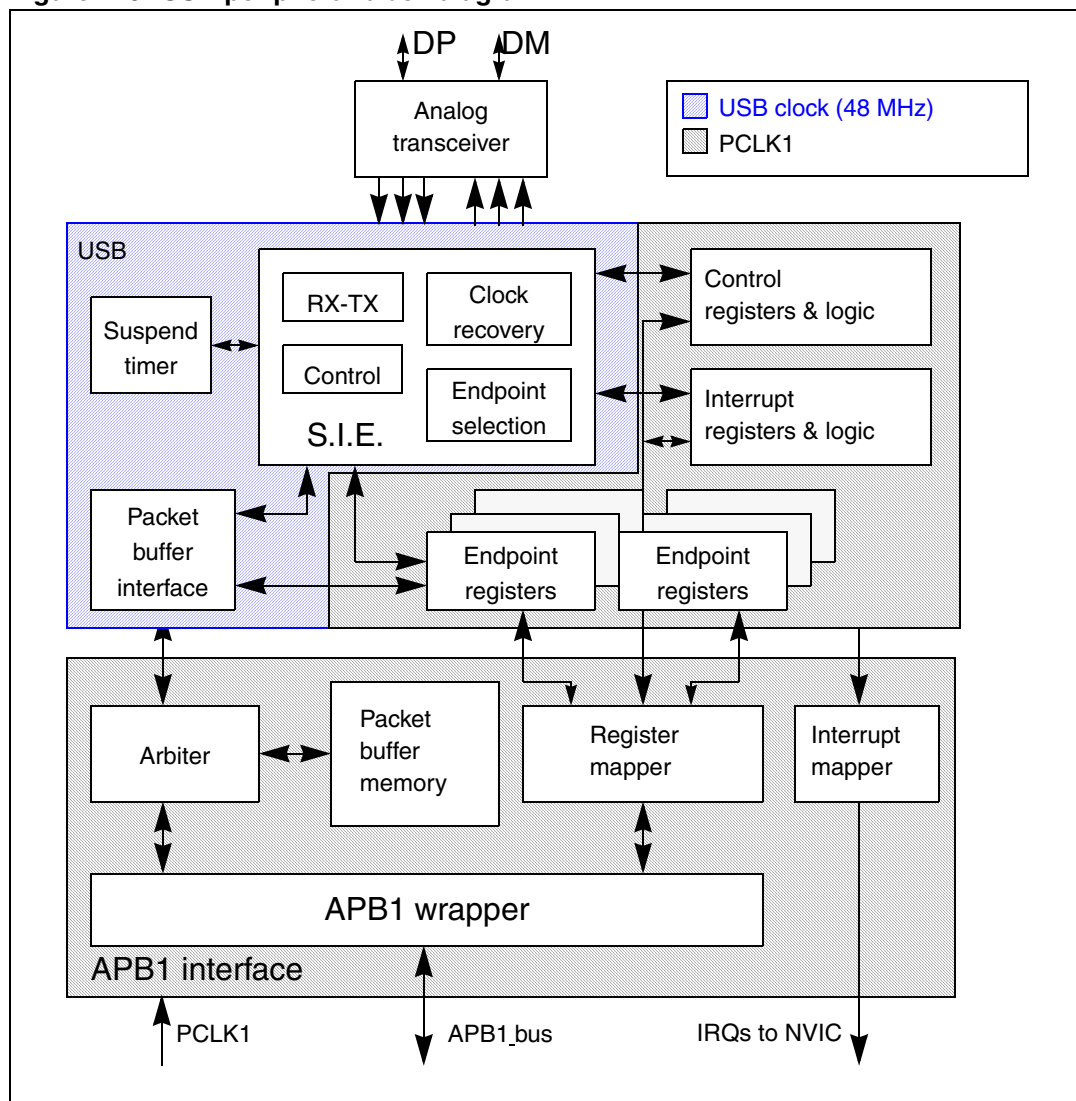
- USB specification version 2.0 full-speed compliant
- Configurable number of endpoints from 1 to 8
- Cyclic redundancy check (CRC) generation/checking, Non-return-to-zero Inverted (NRZI) encoding/decoding and bit-stuffing
- Isochronous transfers support
- Double-buffered bulk/isochronous endpoint support
- USB Suspend/Resume operations
- Frame locked clock pulse generation

*Note:* The USB uses a dedicated 512-byte SRAM memory for data transmission and reception (only the USB accesses this SRAM).

### 22.3 USB functional description

*Figure 219* shows the block diagram of the USB peripheral.

Figure 219. USB peripheral block diagram



The USB peripheral provides an USB compliant connection between the host PC and the function implemented by the microcontroller. Data transfer between the host PC and the system memory occurs through a dedicated packet buffer memory accessed directly by the USB peripheral. The size of this dedicated buffer memory must be according to the number of endpoints used and the maximum packet size. This dedicated memory is sized to 512 bytes and up to 16 mono-directional or 8 bidirectional endpoints can be used. The USB peripheral interfaces with the USB host, detecting token packets, handling data transmission/reception, and processing handshake packets as required by the USB standard. Transaction formatting is performed by the hardware, including CRC generation and checking.

Each endpoint is associated with a buffer description block indicating where the endpoint related memory area is located, how large it is or how many bytes must be transmitted. When a token for a valid function/endpoint pair is recognized by the USB peripheral, the related data transfer (if required and if the endpoint is configured) takes place. The data buffered by the USB peripheral is loaded in an internal 16 bit register and memory access to the dedicated buffer is performed. When all the data has been transferred, if needed, the

proper handshake packet over the USB is generated or expected according to the direction of the transfer.

At the end of the transaction, an endpoint-specific interrupt is generated, reading status registers and/or using different interrupt response routines. The microcontroller can determine:

- Which endpoint has to be served
- Which type of transaction took place, if errors occurred (bit stuffing, format, CRC, protocol, missing ACK, over/underrun, etc.)

Special support is offered to Isochronous transfers and high throughput bulk transfers, implementing a double buffer usage, which allows to always have an available buffer for the USB peripheral while the microcontroller uses the other one.

The unit can be placed in low-power mode (SUSPEND mode), by writing in the control register, whenever required. At this time, all static power dissipation is avoided, and the USB clock can be slowed down or stopped. The detection of activity at the USB inputs, while in low-power mode, wakes the device up asynchronously. A special interrupt source can be connected directly to a wakeup line to allow the system to immediately restart the normal clock generation and/or support direct clock start/stop.

### 22.3.1 Description of USB blocks

The USB peripheral implements all the features related to USB interfacing, which include the following blocks:

- **Serial Interface Engine (SIE):** The functions of this block include: synchronization pattern recognition, bit-stuffing, CRC generation and checking, PID verification/generation, and handshake evaluation. It must interface with the USB transceivers and uses the virtual buffers provided by the packet buffer interface for local data storage. This unit also generates signals according to USB peripheral events, such as Start of Frame (SOF), USB\_Reset, Data errors etc. and to Endpoint related events like end of transmission or correct reception of a packet; these signals are then used to generate interrupts.
- **Timer:** This block generates a start-of-frame locked clock pulse and detects a global suspend (from the host) when no traffic has been received for 3 ms.
- **Packet Buffer Interface:** This block manages the local memory implementing a set of buffers in a flexible way, both for transmission and reception. It can choose the proper buffer according to requests coming from the SIE and locate them in the memory addresses pointed by the Endpoint registers. It increments the address after each exchanged word until the end of packet, keeping track of the number of exchanged bytes and preventing the buffer to overrun the maximum capacity.
- **Endpoint-Related Registers:** Each endpoint has an associated register containing the endpoint type and its current status. For mono-directional/single-buffer endpoints, a single register can be used to implement two distinct endpoints. The number of registers is 8, allowing up to 16 mono-directional/single-buffer or up to 7 double-buffer endpoints\* in any combination. For example the USB peripheral can be programmed to have 4 double buffer endpoints and 8 single-buffer/mono-directional endpoints.

- Control Registers: These are the registers containing information about the status of the whole USB peripheral and used to force some USB events, such as resume and power-down.
- Interrupt Registers: These contain the Interrupt masks and a record of the events. They can be used to inquire an interrupt reason, the interrupt status or to clear the status of a pending interrupt.

*Note:* \* Endpoint 0 is always used for control transfer in single-buffer mode.

The USB peripheral is connected to the APB1 bus through an APB1 interface, containing the following blocks:

- Packet Memory: This is the local memory that physically contains the Packet Buffers. It can be used by the Packet Buffer interface, which creates the data structure and can be accessed directly by the application software. The size of the Packet Memory is 512 bytes, structured as 256 words by 16 bits.
- Arbiter: This block accepts memory requests coming from the APB1 bus and from the USB interface. It resolves the conflicts by giving priority to APB1 accesses, while always reserving half of the memory bandwidth to complete all USB transfers. This time-duplex scheme implements a virtual dual-port SRAM that allows memory access, while an USB transaction is happening. Multiword APB1 transfers of any length are also allowed by this scheme.
- Register Mapper: This block collects the various byte-wide and bit-wide registers of the USB peripheral in a structured 16-bit wide word set addressed by the APB1.
- APB1 Wrapper: This provides an interface to the APB1 for the memory and register. It also maps the whole USB peripheral in the APB1 address space.
- Interrupt Mapper: This block is used to select how the possible USB events can generate interrupts and map them to three different lines of the NVIC:
  - USB low-priority interrupt (Channel 20): Triggered by all USB events (Correct transfer, USB reset, etc.). The firmware has to check the interrupt source before serving the interrupt.
  - USB high-priority interrupt (Channel 19): Triggered only by a correct transfer event for isochronous and double-buffer bulk transfer to reach the highest possible transfer rate.
  - USB wakeup interrupt (Channel 42): Triggered by the wakeup event from the USB Suspend mode.

## 22.4 Programming considerations

In the following sections, the expected interactions between the USB peripheral and the application program are described, in order to ease application software development.

### 22.4.1 Generic USB device programming

This part describes the main tasks required of the application software in order to obtain USB compliant behavior. The actions related to the most general USB events are taken into account and paragraphs are dedicated to the special cases of double-buffered endpoints and Isochronous transfers. Apart from system reset, action is always initiated by the USB peripheral, driven by one of the USB events described below.

## 22.4.2 System and power-on reset

Upon system and power-on reset, the first operation the application software should perform is to provide all required clock signals to the USB peripheral and subsequently de-assert its reset signal so to be able to access its registers. The whole initialization sequence is hereafter described.

As a first step application software needs to activate register macrocell clock and de-assert macrocell specific reset signal using related control bits provided by device clock management logic.

After that, the analog part of the device related to the USB transceiver must be switched on using the PDWN bit in CNTR register, which requires a special handling. This bit is intended to switch on the internal voltage references that supply the port transceiver. This circuit has a defined startup time ( $t_{\text{STARTUP}}$  specified in the datasheet) during which the behavior of the USB transceiver is not defined. It is thus necessary to wait this time, after setting the PDWN bit in the CNTR register, before removing the reset condition on the USB part (by clearing the FRES bit in the CNTR register). Clearing the ISTR register then removes any spurious pending interrupt before any other macrocell operation is enabled.

At system reset, the microcontroller must initialize all required registers and the packet buffer description table, to make the USB peripheral able to properly generate interrupts and data transfers. All registers not specific to any endpoint must be initialized according to the needs of application software (choice of enabled interrupts, chosen address of packet buffers, etc.). Then the process continues as for the USB reset case (see further paragraph).

### USB reset (RESET interrupt)

When this event occurs, the USB peripheral is put in the same conditions it is left by the system reset after the initialization described in the previous paragraph: communication is disabled in all endpoint registers (the USB peripheral will not respond to any packet). As a response to the USB reset event, the USB function must be enabled, having as USB address 0, implementing only the default control endpoint (endpoint address is 0 too). This is accomplished by setting the Enable Function (EF) bit of the USB\_DADDR register and initializing the EP0R register and its related packet buffers accordingly. During USB enumeration process, the host assigns a unique address to this device, which must be written in the ADD[6:0] bits of the USB\_DADDR register, and configures any other necessary endpoint.

When a RESET interrupt is received, the application software is responsible to enable again the default endpoint of USB function 0 within 10mS from the end of reset sequence which triggered the interrupt.

### Structure and usage of packet buffers

Each bidirectional endpoint may receive or transmit data from/to the host. The received data is stored in a dedicated memory buffer reserved for that endpoint, while another memory buffer contains the data to be transmitted by the endpoint. Access to this memory is performed by the packet buffer interface block, which delivers a memory access request and waits for its acknowledgement. Since the packet buffer memory has to be accessed by the microcontroller also, an arbitration logic takes care of the access conflicts, using half APB1 cycle for microcontroller access and the remaining half for the USB peripheral access. In this way, both the agents can operate as if the packet memory is a dual-port SRAM, without being aware of any conflict even when the microcontroller is performing back-to-back accesses. The USB peripheral logic uses a dedicated clock. The frequency of this dedicated

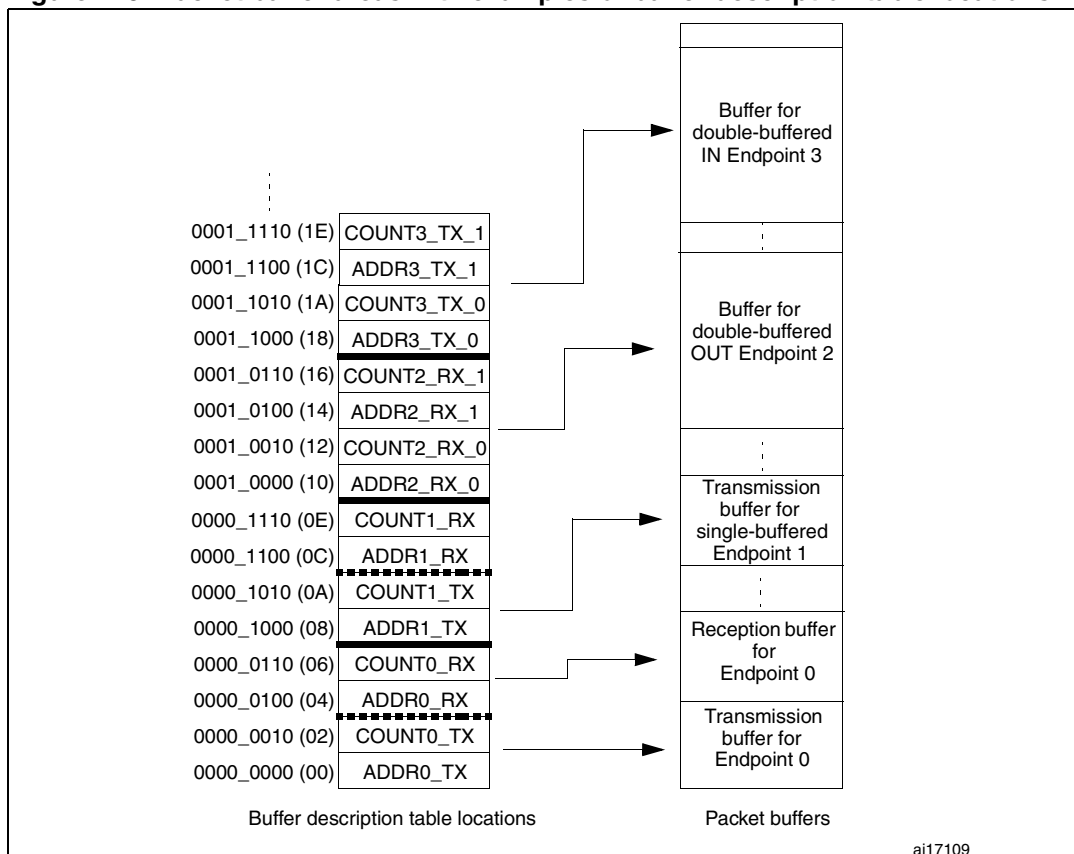


clock is fixed by the requirements of the USB standard at 48 MHz, and this can be different from the clock used for the interface to the APB1 bus. Different clock configurations are possible where the APB1 clock frequency can be higher or lower than the USB peripheral one.

*Note:* Due to USB data rate and packet memory interface requirements, the APB1 clock frequency must be greater than 8 MHz to avoid data overrun/underrun problems.

Each endpoint is associated with two packet buffers (usually one for transmission and the other one for reception). Buffers can be placed anywhere inside the packet memory because their location and size is specified in a buffer description table, which is also located in the packet memory at the address indicated by the USB\_BTABLE register. Each table entry is associated to an endpoint register and it is composed of four 16-bit words so that table start address must always be aligned to an 8-byte boundary (the lowest three bits of USB\_BTABLE register are always “000”). Buffer descriptor table entries are described in the [Section 22.5.3: Buffer descriptor table](#). If an endpoint is unidirectional and it is neither an Isochronous nor a double-buffered bulk, only one packet buffer is required (the one related to the supported transfer direction). Other table locations related to unsupported transfer directions or unused endpoints, are available to the user. isochronous and double-buffered bulk endpoints have special handling of packet buffers (Refer to [Section 22.4.4: Isochronous transfers](#) and [Section 22.4.3: Double-buffered endpoints](#) respectively). The relationship between buffer description table entries and packet buffer areas is depicted in [Figure 220](#).

**Figure 220. Packet buffer areas with examples of buffer description table locations**



Each packet buffer is used either during reception or transmission starting from the bottom. The USB peripheral will never change the contents of memory locations adjacent to the

allocated memory buffers; if a packet bigger than the allocated buffer length is received (buffer overrun condition) the data will be copied to the memory only up to the last available location.

### Endpoint initialization

The first step to initialize an endpoint is to write appropriate values to the ADDRn\_TX/ADDRn\_RX registers so that the USB peripheral finds the data to be transmitted already available and the data to be received can be buffered. The EP\_TYPE bits in the USB\_EPnR register must be set according to the endpoint type, eventually using the EP\_KIND bit to enable any special required feature. On the transmit side, the endpoint must be enabled using the STAT\_TX bits in the USB\_EPnR register and COUNTn\_TX must be initialized. For reception, STAT\_RX bits must be set to enable reception and COUNTn\_RX must be written with the allocated buffer size using the BL\_SIZE and NUM\_BLOCK fields. Unidirectional endpoints, except Isochronous and double-buffered bulk endpoints, need to initialize only bits and registers related to the supported direction. Once the transmission and/or reception are enabled, register USB\_EPnR and locations ADDRn\_TX/ADDRn\_RX, COUNTn\_TX/COUNTn\_RX (respectively), should not be modified by the application software, as the hardware can change their value on the fly. When the data transfer operation is completed, notified by a CTR interrupt event, they can be accessed again to re-enable a new operation.

### IN packets (data transmission)

When receiving an IN token packet, if the received address matches a configured and valid endpoint one, the USB peripheral accesses the contents of ADDRn\_TX and COUNTn\_TX locations inside buffer descriptor table entry related to the addressed endpoint. The content of these locations is stored in its internal 16 bit registers ADDR and COUNT (not accessible by software). The packet memory is accessed again to read the first word to be transmitted (Refer to [Structure and usage of packet buffers on page 584](#)) and starts sending a DATA0 or DATA1 PID according to USB\_EPnR bit DTOG\_TX. When the PID is completed, the first byte from the word, read from buffer memory, is loaded into the output shift register to be transmitted on the USB bus. After the last data byte is transmitted, the computed CRC is sent. If the addressed endpoint is not valid, a NAK or STALL handshake packet is sent instead of the data packet, according to STAT\_TX bits in the USB\_EPnR register.

The ADDR internal register is used as a pointer to the current buffer memory location while COUNT is used to count the number of remaining bytes to be transmitted. Each word read from the packet buffer memory is transmitted over the USB bus starting from the least significant byte. Transmission buffer memory is read starting from the address pointed by ADDRn\_TX for COUNTn\_TX/2 words. If a transmitted packet is composed of an odd number of bytes, only the lower half of the last word accessed will be used.

On receiving the ACK receipt by the host, the USB\_EPnR register is updated in the following way: DTOG\_TX bit is toggled, the endpoint is made invalid by setting STAT\_TX=10 (NAK) and bit CTR\_TX is set. The application software must first identify the endpoint, which is requesting microcontroller attention by examining the EP\_ID and DIR bits in the USB\_ISTR register. Servicing of the CTR\_TX event starts clearing the interrupt bit; the application software then prepares another buffer full of data to be sent, updates the COUNTn\_TX table location with the number of byte to be transmitted during the next transfer, and finally sets STAT\_TX to '11 (VALID) to re-enable transmissions. While the STAT\_TX bits are equal to '10 (NAK), any IN request addressed to that endpoint is NAKed, indicating a flow control condition: the USB host will retry the transaction until it succeeds. It is mandatory to execute the sequence of operations in the above mentioned order to avoid losing the notification of a

second IN transaction addressed to the same endpoint immediately following the one which triggered the CTR interrupt.

### OUT and SETUP packets (data reception)

These two tokens are handled by the USB peripheral more or less in the same way; the differences in the handling of SETUP packets are detailed in the following paragraph about control transfers. When receiving an OUT/SETUP PID, if the address matches a valid endpoint, the USB peripheral accesses the contents of the ADDRn\_RX and COUNTn\_RX locations inside the buffer descriptor table entry related to the addressed endpoint. The content of the ADDRn\_RX is stored directly in its internal register ADDR. While COUNT is now reset and the values of BL\_SIZE and NUM\_BLOCK bit fields, which are read within COUNTn\_RX content are used to initialize BUF\_COUNT, an internal 16 bit counter, which is used to check the buffer overrun condition (all these internal registers are not accessible by software). Data bytes subsequently received by the USB peripheral are packed in words (the first byte received is stored as least significant byte) and then transferred to the packet buffer starting from the address contained in the internal ADDR register while BUF\_COUNT is decremented and COUNT is incremented at each byte transfer. When the end of DATA packet is detected, the correctness of the received CRC is tested and only if no errors occurred during the reception, an ACK handshake packet is sent back to the transmitting host. In case of wrong CRC or other kinds of errors (bit-stuff violations, frame errors, etc.), data bytes are still copied in the packet memory buffer, at least until the error detection point, but ACK packet is not sent and the ERR bit in USB\_ISTR register is set. However, there is usually no software action required in this case: the USB peripheral recovers from reception errors and remains ready for the next transaction to come. If the addressed endpoint is not valid, a NAK or STALL handshake packet is sent instead of the ACK, according to bits STAT\_RX in the USB\_EPnR register and no data is written in the reception memory buffers.

Reception memory buffer locations are written starting from the address contained in the ADDRn\_RX for a number of bytes corresponding to the received data packet length, CRC included (i.e. data payload length + 2), or up to the last allocated memory location, as defined by BL\_SIZE and NUM\_BLOCK, whichever comes first. In this way, the USB peripheral never writes beyond the end of the allocated reception memory buffer area. If the length of the data packet payload (actual number of bytes used by the application) is greater than the allocated buffer, the USB peripheral detects a buffer overrun condition. In this case, a STALL handshake is sent instead of the usual ACK to notify the problem to the host, no interrupt is generated and the transaction is considered failed.

When the transaction is completed correctly, by sending the ACK handshake packet, the internal COUNT register is copied back in the COUNTn\_RX location inside the buffer description table entry, leaving unaffected BL\_SIZE and NUM\_BLOCK fields, which normally do not require to be re-written, and the USB\_EPnR register is updated in the following way: DTOG\_RX bit is toggled, the endpoint is made invalid by setting STAT\_RX = '10 (NAK) and bit CTR\_RX is set. If the transaction has failed due to errors or buffer overrun condition, none of the previously listed actions take place. The application software must first identify the endpoint, which is requesting microcontroller attention by examining the EP\_ID and DIR bits in the USB\_ISTR register. The CTR\_RX event is serviced by first determining the transaction type (SETUP bit in the USB\_EPnR register); the application software must clear the interrupt flag bit and get the number of received bytes reading the COUNTn\_RX location inside the buffer description table entry related to the endpoint being processed. After the received data is processed, the application software should set the STAT\_RX bits to '11 (Valid) in the USB\_EPnR, enabling further transactions. While the STAT\_RX bits are equal to '10 (NAK), any OUT request addressed to that endpoint is NAKed, indicating a flow control condition: the USB host will retry the transaction until it

succeeds. It is mandatory to execute the sequence of operations in the above mentioned order to avoid losing the notification of a second OUT transaction addressed to the same endpoint following immediately the one which triggered the CTR interrupt.

### Control transfers

Control transfers are made of a SETUP transaction, followed by zero or more data stages, all of the same direction, followed by a status stage (a zero-byte transfer in the opposite direction). SETUP transactions are handled by control endpoints only and are very similar to OUT ones (data reception) except that the values of DTOG\_TX and DTOG\_RX bits of the addressed endpoint registers are set to 1 and 0 respectively, to initialize the control transfer, and both STAT\_TX and STAT\_RX are set to '10 (NAK) to let software decide if subsequent transactions must be IN or OUT depending on the SETUP contents. A control endpoint must check SETUP bit in the USB\_EPnR register at each CTR\_RX event to distinguish normal OUT transactions from SETUP ones. A USB device can determine the number and direction of data stages by interpreting the data transferred in the SETUP stage, and is required to STALL the transaction in the case of errors. To do so, at all data stages before the last, the unused direction should be set to STALL, so that, if the host reverses the transfer direction too soon, it gets a STALL as a status stage. While enabling the last data stage, the opposite direction should be set to NAK, so that, if the host reverses the transfer direction (to perform the status stage) immediately, it is kept waiting for the completion of the control operation. If the control operation completes successfully, the software will change NAK to VALID, otherwise to STALL. At the same time, if the status stage will be an OUT, the STATUS\_OUT (EP\_KIND in the USB\_EPnR register) bit should be set, so that an error is generated if a status transaction is performed with not-zero data. When the status transaction is serviced, the application clears the STATUS\_OUT bit and sets STAT\_RX to VALID (to accept a new command) and STAT\_TX to NAK (to delay a possible status stage immediately following the next setup).

Since the USB specification states that a SETUP packet cannot be answered with a handshake different from ACK, eventually aborting a previously issued command to start the new one, the USB logic doesn't allow a control endpoint to answer with a NAK or STALL packet to a SETUP token received from the host.

When the STAT\_RX bits are set to '01 (STALL) or '10 (NAK) and a SETUP token is received, the USB accepts the data, performing the required data transfers and sends back an ACK handshake. If that endpoint has a previously issued CTR\_RX request not yet acknowledged by the application (i.e. CTR\_RX bit is still set from a previously completed reception), the USB discards the SETUP transaction and does not answer with any handshake packet regardless of its state, simulating a reception error and forcing the host to send the SETUP token again. This is done to avoid losing the notification of a SETUP transaction addressed to the same endpoint immediately following the transaction, which triggered the CTR\_RX interrupt.

### 22.4.3 Double-buffered endpoints

All different endpoint types defined by the USB standard represent different traffic models, and describe the typical requirements of different kind of data transfer operations. When large portions of data are to be transferred between the host PC and the USB function, the bulk endpoint type is the most suited model. This is because the host schedules bulk transactions so as to fill all the available bandwidth in the frame, maximizing the actual transfer rate as long as the USB function is ready to handle a bulk transaction addressed to it. If the USB function is still busy with the previous transaction when the next one arrives, it will answer with a NAK handshake and the host PC will issue the same transaction again until the USB function is ready to handle it, reducing the actual transfer rate due to the bandwidth occupied by re-transmissions. For this reason, a dedicated feature called 'double-buffering' can be used with bulk endpoints.

When 'double-buffering' is activated, data toggle sequencing is used to select, which buffer is to be used by the USB peripheral to perform the required data transfers, using both 'transmission' and 'reception' packet memory areas to manage buffer swapping on each successful transaction in order to always have a complete buffer to be used by the application, while the USB peripheral fills the other one. For example, during an OUT transaction directed to a 'reception' double-buffered bulk endpoint, while one buffer is being filled with new data coming from the USB host, the other one is available for the microcontroller software usage (the same would happen with a 'transmission' double-buffered bulk endpoint and an IN transaction).

Since the swapped buffer management requires the usage of all 4 buffer description table locations hosting the address pointer and the length of the allocated memory buffers, the USB\_EPnR registers used to implement double-buffered bulk endpoints are forced to be used as unidirectional ones. Therefore, only one STAT bit pair must be set at a value different from '00 (Disabled): STAT\_RX if the double-buffered bulk endpoint is enabled for reception, STAT\_TX if the double-buffered bulk endpoint is enabled for transmission. In case it is required to have double-buffered bulk endpoints enabled both for reception and transmission, two USB\_EPnR registers must be used.

To exploit the double-buffering feature and reach the highest possible transfer rate, the endpoint flow control structure, described in previous chapters, has to be modified, in order to switch the endpoint status to NAK only when a buffer conflict occurs between the USB peripheral and application software, instead of doing it at the end of each successful transaction. The memory buffer which is currently being used by the USB peripheral is defined by the DTOG bit related to the endpoint direction: DTOG\_RX (bit 14 of USB\_EPnR register) for 'reception' double-buffered bulk endpoints or DTOG\_TX (bit 6 of USB\_EPnR register) for 'transmission' double-buffered bulk endpoints. To implement the new flow control scheme, the USB peripheral should know which packet buffer is currently in use by the application software, so to be aware of any conflict. Since in the USB\_EPnR register, there are two DTOG bits but only one is used by USB peripheral for data and buffer sequencing (due to the unidirectional constraint required by double-buffering feature) the other one can be used by the application software to show which buffer it is currently using. This new buffer flag is called SW\_BUF. In the following table the correspondence between USB\_EPnR register bits and DTOG/SW\_BUF definition is explained, for the cases of 'transmission' and 'reception' double-buffered bulk endpoints.

**Table 166. Double-buffering buffer flag definition**

Buffer flag	'Transmission' endpoint	'Reception' endpoint
DTOG	DTOG_TX (USB_EPnRbit 6)	DTOG_RX (USB_EPnRbit 14)
SW_BUF	USB_EPnR bit 14	USB_EPnR bit 6

The memory buffer which is currently being used by the USB peripheral is defined by DTOG buffer flag, while the buffer currently in use by application software is identified by SW\_BUF buffer flag. The relationship between the buffer flag value and the used packet buffer is the same in both cases, and it is listed in the following table.

**Table 167. Bulk double-buffering memory buffers usage**

Endpoint Type	DTOG	SW_BUF	Packet buffer used by USB Peripheral	Packet buffer used by Application Software
IN	0	1	ADDRn_TX_0 / COUNTn_TX_0 Buffer description table locations.	ADDRn_TX_1 / COUNTn_TX_1 Buffer description table locations.
	1	0	ADDRn_TX_1 / COUNTn_TX_1 Buffer description table locations.	ADDRn_TX_0 / COUNTn_TX_0 Buffer description table locations.
	0	0	None <sup>(1)</sup>	ADDRn_TX_0 / COUNTn_TX_0 Buffer description table locations.
	1	1	None <sup>(1)</sup>	ADDRn_TX_0 / COUNTn_TX_0 Buffer description table locations.
OUT	0	1	ADDRn_RX_0 / COUNTn_RX_0 Buffer description table locations.	ADDRn_RX_1 / COUNTn_RX_1 Buffer description table locations.
	1	0	ADDRn_RX_1 / COUNTn_RX_1 Buffer description table locations.	ADDRn_RX_0 / COUNTn_RX_0 Buffer description table locations.
	0	0	None <sup>(1)</sup>	ADDRn_RX_0 / COUNTn_RX_0 Buffer description table locations.
	1	1	None <sup>(1)</sup>	ADDRn_RX_1 / COUNTn_RX_1 Buffer description table locations.

1. Endpoint in NAK Status.

Double-buffering feature for a bulk endpoint is activated by:

- Writing EP\_TYPE bit field at '00 in its USB\_EPnR register, to define the endpoint as a bulk, and
- Setting EP\_KIND bit at '1 (DBL\_BUF), in the same register.

The application software is responsible for DTOG and SW\_BUF bits initialization according to the first buffer to be used; this has to be done considering the special toggle-only property that these two bits have. The end of the first transaction occurring after having set DBL\_BUF, triggers the special flow control of double-buffered bulk endpoints, which is used for all other transactions addressed to this endpoint until DBL\_BUF remain set. At the end of each transaction the CTR\_RX or CTR\_TX bit of the addressed endpoint USB\_EPnR register is set, depending on the enabled direction. At the same time, the affected DTOG bit in the USB\_EPnR register is hardware toggled making the USB peripheral buffer swapping completely software independent. Unlike common transactions, and the first one after

DBL\_BUF setting, STAT bit pair is not affected by the transaction termination and its value remains '11 (Valid). However, as the token packet of a new transaction is received, the actual endpoint status will be masked as '10 (NAK) when a buffer conflict between the USB peripheral and the application software is detected (this condition is identified by DTOG and SW\_BUF having the same value, see [Table 167 on page 590](#)). The application software responds to the CTR event notification by clearing the interrupt flag and starting any required handling of the completed transaction. When the application packet buffer usage is over, the software toggles the SW\_BUF bit, writing '1 to it, to notify the USB peripheral about the availability of that buffer. In this way, the number of NAKed transactions is limited only by the application elaboration time of a transaction data: if the elaboration time is shorter than the time required to complete a transaction on the USB bus, no re-transmissions due to flow control will take place and the actual transfer rate will be limited only by the host PC.

The application software can always override the special flow control implemented for double-buffered bulk endpoints, writing an explicit status different from '11 (Valid) into the STAT bit pair of the related USB\_EPnR register. In this case, the USB peripheral will always use the programmed endpoint status, regardless of the buffer usage condition.

#### 22.4.4 Isochronous transfers

The USB standard supports full speed peripherals requiring a fixed and accurate data production/consume frequency, defining this kind of traffic as 'Isochronous'. Typical examples of this data are: audio samples, compressed video streams, and in general any sort of sampled data having strict requirements for the accuracy of delivered frequency. When an endpoint is defined to be 'isochronous' during the enumeration phase, the host allocates in the frame the required bandwidth and delivers exactly one IN or OUT packet each frame, depending on endpoint direction. To limit the bandwidth requirements, no re-transmission of failed transactions is possible for Isochronous traffic; this leads to the fact that an isochronous transaction does not have a handshake phase and no ACK packet is expected or sent after the data packet. For the same reason, Isochronous transfers do not support data toggle sequencing and always use DATA0 PID to start any data packet.

The Isochronous behavior for an endpoint is selected by setting the EP\_TYPE bits at '10 in its USB\_EPnR register; since there is no handshake phase the only legal values for the STAT\_RX/STAT\_TX bit pairs are '00 (Disabled) and '11 (Valid), any other value will produce results not compliant to USB standard. Isochronous endpoints implement double-buffering to ease application software development, using both 'transmission' and 'reception' packet memory areas to manage buffer swapping on each successful transaction in order to have always a complete buffer to be used by the application, while the USB peripheral fills the other.

The memory buffer which is currently used by the USB peripheral is defined by the DTOG bit related to the endpoint direction (DTOG\_RX for 'reception' isochronous endpoints, DTOG\_TX for 'transmission' isochronous endpoints, both in the related USB\_EPnR register) according to [Table 168](#).

**Table 168. Isochronous memory buffers usage**

Endpoint Type	DTOG bit value	Packet buffer used by the USB peripheral	Packet buffer used by the application software
IN	0	ADDRn_TX_0 / COUNTn_TX_0 buffer description table locations.	ADDRn_TX_1 / COUNTn_TX_1 buffer description table locations.
	1	ADDRn_TX_1 / COUNTn_TX_1 buffer description table locations.	ADDRn_TX_0 / COUNTn_TX_0 buffer description table locations.
OUT	0	ADDRn_RX_0 / COUNTn_RX_0 buffer description table locations.	ADDRn_RX_1 / COUNTn_RX_1 buffer description table locations.
	1	ADDRn_RX_1 / COUNTn_RX_1 buffer description table locations.	ADDRn_RX_0 / COUNTn_RX_0 buffer description table locations.

As it happens with double-buffered bulk endpoints, the USB\_EPnR registers used to implement Isochronous endpoints are forced to be used as unidirectional ones. In case it is required to have Isochronous endpoints enabled both for reception and transmission, two USB\_EPnR registers must be used.

The application software is responsible for the DTOG bit initialization according to the first buffer to be used; this has to be done considering the special toggle-only property that these two bits have. At the end of each transaction, the CTR\_RX or CTR\_TX bit of the addressed endpoint USB\_EPnR register is set, depending on the enabled direction. At the same time, the affected DTOG bit in the USB\_EPnR register is hardware toggled making buffer swapping completely software independent. STAT bit pair is not affected by transaction completion; since no flow control is possible for Isochronous transfers due to the lack of handshake phase, the endpoint remains always '11 (Valid). CRC errors or buffer-overflow conditions occurring during Isochronous OUT transfers are anyway considered as correct transactions and they always trigger an CTR\_RX event. However, CRC errors will anyway set the ERR bit in the USB\_ISTR register to notify the software of the possible data corruption.

### 22.4.5 Suspend/Resume events

The USB standard defines a special peripheral state, called SUSPEND, in which the average current drawn from the USB bus must not be greater than 500 μA. This requirement is of fundamental importance for bus-powered devices, while self-powered devices are not required to comply to this strict power consumption constraint. In suspend mode, the host PC sends the notification to not send any traffic on the USB bus for more than 3mS: since a SOF packet must be sent every mS during normal operations, the USB peripheral detects the lack of 3 consecutive SOF packets as a suspend request from the host PC and set the SUSP bit to '1 in USB\_ISTR register, causing an interrupt if enabled. Once the device is suspended, its normal operation can be restored by a so called RESUME sequence, which can be started from the host PC or directly from the peripheral itself, but it is always terminated by the host PC. The suspended USB peripheral must be anyway able to detect a RESET sequence, reacting to this event as a normal USB reset event.



The actual procedure used to suspend the USB peripheral is device dependent since according to the device composition, different actions may be required to reduce the total consumption.

A brief description of a typical suspend procedure is provided below, focused on the USB-related aspects of the application software routine responding to the SUSP notification of the USB peripheral:

1. Set the FSUSP bit in the USB\_CNTR register to 1. This action activates the suspend mode within the USB peripheral. As soon as the suspend mode is activated, the check on SOF reception is disabled to avoid any further SUSP interrupts being issued while the USB is suspended.
2. Remove or reduce any static power consumption in blocks different from the USB peripheral.
3. Set LP\_MODE bit in USB\_CNTR register to 1 to remove static power consumption in the analog USB transceivers but keeping them able to detect resume activity.
4. Optionally turn off external oscillator and device PLL to stop any activity inside the device.

When an USB event occurs while the device is in SUSPEND mode, the RESUME procedure must be invoked to restore nominal clocks and regain normal USB behavior. Particular care must be taken to insure that this process does not take more than 10mS when the waking event is an USB reset sequence (See “Universal Serial Bus Specification” for more details). The start of a resume or reset sequence, while the USB peripheral is suspended, clears the LP\_MODE bit in USB\_CNTR register asynchronously. Even if this event can trigger an WKUP interrupt if enabled, the use of an interrupt response routine must be carefully evaluated because of the long latency due to system clock restart; to have the shorter latency before re-activating the nominal clock it is suggested to put the resume procedure just after the end of the suspend one, so its code is immediately executed as soon as the system clock restarts. To prevent ESD discharges or any other kind of noise from waking-up the system (the exit from suspend mode is an asynchronous event), a suitable analog filter on data line status is activated during suspend; the filter width is about 70ns.

The following is a list of actions a resume procedure should address:

1. Optionally turn on external oscillator and/or device PLL.
2. Clear FSUSP bit of USB\_CNTR register.
3. If the resume triggering event has to be identified, bits RXDP and RXDM in the USB\_FNR register can be used according to [Table 169](#), which also lists the intended software action in all the cases. If required, the end of resume or reset sequence can be detected monitoring the status of the above mentioned bits by checking when they reach the “10” configuration, which represent the Idle bus state; moreover at the end of a reset sequence the RESET bit in USB\_ISTR register is set to 1, issuing an interrupt if enabled, which should be handled as usual.

**Table 169. Resume event detection**

[RXDP,RXDM] status	Wakeup event	Required resume software action
“00”	Root reset	None
“10”	None (noise on bus)	Go back in Suspend mode
“01”	Root resume	None
“11”	Not allowed (noise on bus)	Go back in Suspend mode

A device may require to exit from suspend mode as an answer to particular events not directly related to the USB protocol (e.g. a mouse movement wakes up the whole system). In this case, the resume sequence can be started by setting the RESUME bit in the USB\_CNTR register to '1 and resetting it to 0 after an interval between 1mS and 15mS (this interval can be timed using ESOF interrupts, occurring with a 1mS period when the system clock is running at nominal frequency). Once the RESUME bit is clear, the resume sequence will be completed by the host PC and its end can be monitored again using the RXDP and RXDM bits in the USB\_FNR register.

*Note:* The RESUME bit must be anyway used only after the USB peripheral has been put in suspend mode, setting the FSUSP bit in USB\_CNTR register to 1.

## 22.5 USB registers

The USB peripheral registers can be divided into the following groups:

- Common Registers: Interrupt and Control registers
- Endpoint Registers: Endpoint configuration and status
- Buffer Descriptor Table: Location of packet memory used to locate data buffers

All register addresses are expressed as offsets with respect to the USB peripheral registers base address 0x4000 5C00, except the buffer descriptor table locations, which starts at the address specified by the USB\_BTABLE register. Due to the common limitation of APB1 bridges on word addressability, all register addresses are aligned to 32-bit word boundaries although they are 16-bit wide. The same address alignment is used to access packet buffer memory locations, which are located starting from 0x4000 6000.

Refer to [Section 1.1 on page 40](#) for a list of abbreviations used in register descriptions.

The peripheral registers can be accessed by half-words (16-bit) or words (32-bit).

### 22.5.1 Common registers

These registers affect the general behavior of the USB peripheral defining operating mode, interrupt handling, device address and giving access to the current frame number updated by the host PC.

#### USB control register (USB\_CNTR)

Address offset: 0x40

Reset value: 0x0003

15	14	13	12	11	10	9	8	7	6	5	4	3	2	1	0
CTRM	PMAOVRM	ERRM	WKUPM	SUSPM	RESETM	SOFM	ESOFM	Reserved			RESUME	FSUSP	LP_MODE	PDWN	FRES
rw	rw	rw	rw	rw	rw	rw	rw	Res.			rw	rw	rw	rw	rw

Bit 15 **CTRM**: Correct transfer interrupt mask

0: Correct Transfer (CTR) Interrupt disabled.

1: CTR Interrupt enabled, an interrupt request is generated when the corresponding bit in the USB\_ISTR register is set.

- Bit 14 **PMAOVRM**: Packet memory area over / underrun interrupt mask  
0: PMAOVR Interrupt disabled.  
1: PMAOVR Interrupt enabled, an interrupt request is generated when the corresponding bit in the USB\_ISTR register is set.
- Bit 13 **ERRM**: Error interrupt mask  
0: ERR Interrupt disabled.  
1: ERR Interrupt enabled, an interrupt request is generated when the corresponding bit in the USB\_ISTR register is set.
- Bit 12 **WKUPM**: Wakeup interrupt mask  
0: WKUP Interrupt disabled.  
1: WKUP Interrupt enabled, an interrupt request is generated when the corresponding bit in the USB\_ISTR register is set.
- Bit 11 **SUSPM**: Suspend mode interrupt mask  
0: Suspend Mode Request (SUSP) Interrupt disabled.  
1: SUSP Interrupt enabled, an interrupt request is generated when the corresponding bit in the USB\_ISTR register is set.
- Bit 10 **RESETM**: USB reset interrupt mask  
0: RESET Interrupt disabled.  
1: RESET Interrupt enabled, an interrupt request is generated when the corresponding bit in the USB\_ISTR register is set.
- Bit 9 **SOFM**: Start of frame interrupt mask  
0: SOF Interrupt disabled.  
1: SOF Interrupt enabled, an interrupt request is generated when the corresponding bit in the USB\_ISTR register is set.
- Bit 8 **ESOFM**: Expected start of frame interrupt mask  
0: Expected Start of Frame (ESOF) Interrupt disabled.  
1: ESOF Interrupt enabled, an interrupt request is generated when the corresponding bit in the USB\_ISTR register is set.
- Bits 7:5 Reserved.
- Bit 4 **RESUME**: Resume request  
The microcontroller can set this bit to send a Resume signal to the host. It must be activated, according to USB specifications, for no less than 1mS and no more than 15mS after which the Host PC is ready to drive the resume sequence up to its end.
- Bit 3 **FSUSP**: Force suspend  
Software must set this bit when the SUSP interrupt is received, which is issued when no traffic is received by the USB peripheral for 3 mS.  
0: No effect.  
1: Enter suspend mode. Clocks and static power dissipation in the analog transceiver are left unaffected. If suspend power consumption is a requirement (bus-powered device), the application software should set the LP\_MODE bit after FSUSP as explained below.
- Bit 2 **LP\_MODE**: Low-power mode  
This mode is used when the suspend-mode power constraints require that all static power dissipation is avoided, except the one required to supply the external pull-up resistor. This condition should be entered when the application is ready to stop all system clocks, or reduce their frequency in order to meet the power consumption requirements of the USB suspend condition. The USB activity during the suspend mode (WKUP event) asynchronously resets this bit (it can also be reset by software).  
0: No Low-power mode.  
1: Enter Low-power mode.

Bit 1 **PDWN**: Power down

This bit is used to completely switch off all USB-related analog parts if it is required to completely disable the USB peripheral for any reason. When this bit is set, the USB peripheral is disconnected from the transceivers and it cannot be used.  
 0: Exit Power Down.  
 1: Enter Power down mode.

Bit 0 **FRES**: Force USB Reset

0: Clear USB reset.  
 1: Force a reset of the USB peripheral, exactly like a RESET signalling on the USB. The USB peripheral is held in RESET state until software clears this bit. A “USB-RESET” interrupt is generated, if enabled.

**USB interrupt status register (USB\_ISTR)**

Address offset: 0x44

Reset value: 0x0000 0000

15	14	13	12	11	10	9	8	7	6	5	4	3	2	1	0
CTR	PMA OVR	ERR	WKUP	SUSP	RESET	SOF	ESOF	Reserved			DIR	EP_ID[3:0]			
r	rc_w0	rc_w0	rc_w0	rc_w0	rc_w0	rc_w0	rc_w0	Res.			r	r	r	r	r

This register contains the status of all the interrupt sources allowing application software to determine, which events caused an interrupt request.

The upper part of this register contains single bits, each of them representing a specific event. These bits are set by the hardware when the related event occurs; if the corresponding bit in the USB\_CNTR register is set, a generic interrupt request is generated. The interrupt routine, examining each bit, will perform all necessary actions, and finally it will clear the serviced bits. If any of them is not cleared, the interrupt is considered to be still pending, and the interrupt line will be kept high again. If several bits are set simultaneously, only a single interrupt will be generated.

Endpoint transaction completion can be handled in a different way to reduce interrupt response latency. The CTR bit is set by the hardware as soon as an endpoint successfully completes a transaction, generating a generic interrupt request if the corresponding bit in USB\_CNTR is set. An endpoint dedicated interrupt condition is activated independently from the CTRM bit in the USB\_CNTR register. Both interrupt conditions remain active until software clears the pending bit in the corresponding USB\_EPnR register (the CTR bit is actually a read only bit). For endpoint-related interrupts, the software can use the Direction of Transaction (DIR) and EP\_ID read-only bits to identify, which endpoint made the last interrupt request and called the corresponding interrupt service routine.

The user can choose the relative priority of simultaneously pending USB\_ISTR events by specifying the order in which software checks USB\_ISTR bits in an interrupt service routine. Only the bits related to events, which are serviced, are cleared. At the end of the service routine, another interrupt will be requested, to service the remaining conditions.

To avoid spurious clearing of some bits, it is recommended to clear them with a load instruction where all bits which must not be altered are written with 1, and all bits to be cleared are written with '0 (these bits can only be cleared by software). Read-modify-write cycles should be avoided because between the read and the write operations another bit

could be set by the hardware and the next write will clear it before the microprocessor has the time to serve the event.

The following describes each bit in detail:

Bit 15 **CTR**: Correct transfer

This bit is set by the hardware to indicate that an endpoint has successfully completed a transaction; using DIR and EP\_ID bits software can determine which endpoint requested the interrupt. This bit is read-only.

Bit 14 **PMAOVR**: Packet memory area over / underrun

This bit is set if the microcontroller has not been able to respond in time to an USB memory request. The USB peripheral handles this event in the following way: During reception an ACK handshake packet is not sent, during transmission a bit-stuff error is forced on the transmitted stream; in both cases the host will retry the transaction. The PMAOVR interrupt should never occur during normal operations. Since the failed transaction is retried by the host, the application software has the chance to speed-up device operations during this interrupt handling, to be ready for the next transaction retry; however this does not happen during Isochronous transfers (no isochronous transaction is anyway retried) leading to a loss of data in this case. This bit is read/write but only '0 can be written and writing '1 has no effect.

Bit 13 **ERR**: Error

This flag is set whenever one of the errors listed below has occurred:

NANS: No ANSwer. The timeout for a host response has expired.

CRC: Cyclic Redundancy Check error. One of the received CRCs, either in the token or in the data, was wrong.

BST: Bit Stuffing error. A bit stuffing error was detected anywhere in the PID, data, and/or CRC.

FVIO: Framing format Violation. A non-standard frame was received (EOP not in the right place, wrong token sequence, etc.).

The USB software can usually ignore errors, since the USB peripheral and the PC host manage retransmission in case of errors in a fully transparent way. This interrupt can be useful during the software development phase, or to monitor the quality of transmission over the USB bus, to flag possible problems to the user (e.g. loose connector, too noisy environment, broken conductor in the USB cable and so on). This bit is read/write but only '0 can be written and writing '1 has no effect.

Bit 12 **WKUP**: Wakeup

This bit is set to 1 by the hardware when, during suspend mode, activity is detected that wakes up the USB peripheral. This event asynchronously clears the LP\_MODE bit in the CTLR register and activates the USB\_WAKEUP line, which can be used to notify the rest of the device (e.g. wakeup unit) about the start of the resume process. This bit is read/write but only '0 can be written and writing '1 has no effect.

Bit 11 **SUSP**: Suspend mode request

This bit is set by the hardware when no traffic has been received for 3mS, indicating a suspend mode request from the USB bus. The suspend condition check is enabled immediately after any USB reset and it is disabled by the hardware when the suspend mode is active (FSUSP=1) until the end of resume sequence. This bit is read/write but only '0 can be written and writing '1 has no effect.

**Bit 10 RESET:** USB reset request

Set when the USB peripheral detects an active USB RESET signal at its inputs. The USB peripheral, in response to a RESET, just resets its internal protocol state machine, generating an interrupt if RESETM enable bit in the USB\_CNTR register is set. Reception and transmission are disabled until the RESET bit is cleared. All configuration registers do not reset: the microcontroller must explicitly clear these registers (this is to ensure that the RESET interrupt can be safely delivered, and any transaction immediately followed by a RESET can be completed). The function address and endpoint registers are reset by an USB reset event.

This bit is read/write but only '0 can be written and writing '1 has no effect.

**Bit 9 SOF:** Start of frame

This bit signals the beginning of a new USB frame and it is set when a SOF packet arrives through the USB bus. The interrupt service routine may monitor the SOF events to have a 1mS synchronization event to the USB host and to safely read the USB\_FNR register which is updated at the SOF packet reception (this could be useful for isochronous applications).

This bit is read/write but only '0 can be written and writing '1 has no effect.

**Bit 8 ESOF:** Expected start of frame

This bit is set by the hardware when an SOF packet is expected but not received. The host sends an SOF packet each mS, but if the hub does not receive it properly, the Suspend Timer issues this interrupt. If three consecutive ESOF interrupts are generated (i.e. three SOF packets are lost) without any traffic occurring in between, a SUSP interrupt is generated. This bit is set even when the missing SOF packets occur while the Suspend Timer is not yet locked. This bit is read/write but only '0 can be written and writing '1 has no effect.

Bits 7:5 Reserved.

**Bit 4 DIR:** Direction of transaction

This bit is written by the hardware according to the direction of the successful transaction, which generated the interrupt request.

If DIR bit=0, CTR\_TX bit is set in the USB\_EPnR register related to the interrupting endpoint. The interrupting transaction is of IN type (data transmitted by the USB peripheral to the host PC).

If DIR bit=1, CTR\_RX bit or both CTR\_TX/CTR\_RX are set in the USB\_EPnR register related to the interrupting endpoint. The interrupting transaction is of OUT type (data received by the USB peripheral from the host PC) or two pending transactions are waiting to be processed.

This information can be used by the application software to access the USB\_EPnR bits related to the triggering transaction since it represents the direction having the interrupt pending. This bit is read-only.

**Bits 3:0 EP\_ID[3:0]:** Endpoint Identifier

These bits are written by the hardware according to the endpoint number, which generated the interrupt request. If several endpoint transactions are pending, the hardware writes the endpoint identifier related to the endpoint having the highest priority defined in the following way: Two endpoint sets are defined, in order of priority: Isochronous and double-buffered bulk endpoints are considered first and then the other endpoints are examined. If more than one endpoint from the same set is requesting an interrupt, the EP\_ID bits in USB\_ISTR register are assigned according to the lowest requesting endpoint register, EP0R having the highest priority followed by EP1R and so on. The application software can assign a register to each endpoint according to this priority scheme, so as to order the concurring endpoint requests in a suitable way. These bits are read only.

### USB frame number register (USB\_FNR)

Address offset: 0x48

Reset value: 0x0XXX where X is undefined

15	14	13	12	11	10	9	8	7	6	5	4	3	2	1	0
RXDP	RXDM	LCK	LSOF[1:0]		FN[10:0]										
r	r	r	r	r	r	r	r	r	r	r	r	r	r	r	r

Bit 15 **RXDP**: Receive data + line status

This bit can be used to observe the status of received data plus upstream port data line. It can be used during end-of-suspend routines to help determining the wakeup event.

Bit 14 **RXDM**: Receive data - line status

This bit can be used to observe the status of received data minus upstream port data line. It can be used during end-of-suspend routines to help determining the wakeup event.

Bit 13 **LCK**: Locked

This bit is set by the hardware when at least two consecutive SOF packets have been received after the end of an USB reset condition or after the end of an USB resume sequence. Once locked, the frame timer remains in this state until an USB reset or USB suspend event occurs.

Bits 12:11 **LSOF[1:0]**: Lost SOF

These bits are written by the hardware when an ESOF interrupt is generated, counting the number of consecutive SOF packets lost. At the reception of an SOF packet, these bits are cleared.

Bits 10:0 **FN[10:0]**: Frame number

This bit field contains the 11-bits frame number contained in the last received SOF packet. The frame number is incremented for every frame sent by the host and it is useful for Isochronous transfers. This bit field is updated on the generation of an SOF interrupt.

### USB device address (USB\_DADDR)

Address offset: 0x4C

Reset value: 0x0000

15	14	13	12	11	10	9	8	7	6	5	4	3	2	1	0
Reserved								EF	ADD6	ADD5	ADD4	ADD3	ADD2	ADD1	ADD0
Res.								rw	rw	rw	rw	rw	rw	rw	rw

Bits 15:8 Reserved

Bit 7 **EF**: Enable function

This bit is set by the software to enable the USB device. The address of this device is contained in the following ADD[6:0] bits. If this bit is at '0 no transactions are handled, irrespective of the settings of USB\_EPnR registers.

Bits 6:0 **ADD[6:0]**: Device address

These bits contain the USB function address assigned by the host PC during the enumeration process. Both this field and the Endpoint Address (EA) field in the associated USB\_EPnR register must match with the information contained in a USB token in order to handle a transaction to the required endpoint.

**Buffer table address (USB\_BTABLE)**

Address offset: 0x50

Reset value: 0x0000

15	14	13	12	11	10	9	8	7	6	5	4	3	2	1	0
BTABLE[15:3]													Reserved		
rw	rw	rw	rw	rw	rw	rw	rw	rw	rw	rw	rw	rw	Res.		

Bits 15:3 **BTABLE[15:3]**: Buffer table

These bits contain the start address of the buffer allocation table inside the dedicated packet memory. This table describes each endpoint buffer location and size and it must be aligned to an 8 byte boundary (the 3 least significant bits are always '0'). At the beginning of every transaction addressed to this device, the USP peripheral reads the element of this table related to the addressed endpoint, to get its buffer start location and the buffer size (Refer to [Structure and usage of packet buffers on page 584](#)).

Bits 2:0 Reserved, forced by hardware to 0.

**22.5.2 Endpoint-specific registers**

The number of these registers varies according to the number of endpoints that the USB peripheral is designed to handle. The USB peripheral supports up to 8 bidirectional endpoints. Each USB device must support a control endpoint whose address (EA bits) must be set to 0. The USB peripheral behaves in an undefined way if multiple endpoints are enabled having the same endpoint number value. For each endpoint, an USB\_EPnR register is available to store the endpoint specific information.

**USB endpoint n register (USB\_EPnR), n=[0..7]**

Address offset: 0x00 to 0x1C

Reset value: 0x0000

15	14	13	12	11	10	9	8	7	6	5	4	3	2	1	0
CTR_RX	DTOG_RX	STAT_RX[1:0]		SETUP	EP_TYPE[1:0]		EP_KIND	CTR_TX	DTOG_TX	STAT_TX[1:0]		EA[3:0]			
rc_w0	t	t	t	r	rw	rw	rw	rc_w0	t	t	t	rw	rw	rw	rw

They are also reset when an USB reset is received from the USB bus or forced through bit FRES in the CTLR register, except the CTR\_RX and CTR\_TX bits, which are kept unchanged to avoid missing a correct packet notification immediately followed by an USB reset event. Each endpoint has its USB\_EPnR register where n is the endpoint identifier.



Read-modify-write cycles on these registers should be avoided because between the read and the write operations some bits could be set by the hardware and the next write would modify them before the CPU has the time to detect the change. For this purpose, all bits affected by this problem have an 'invariant' value that must be used whenever their modification is not required. It is recommended to modify these registers with a load instruction where all the bits, which can be modified only by the hardware, are written with their 'invariant' value.

Bit 15 **CTR\_RX**: Correct Transfer for reception

This bit is set by the hardware when an OUT/SETUP transaction is successfully completed on this endpoint; the software can only clear this bit. If the CTRM bit in USB\_CNTR register is set accordingly, a generic interrupt condition is generated together with the endpoint related interrupt condition, which is always activated. The type of occurred transaction, OUT or SETUP, can be determined from the SETUP bit described below.

A transaction ended with a NAK or STALL handshake does not set this bit, since no data is actually transferred, as in the case of protocol errors or data toggle mismatches.

This bit is read/write but only '0' can be written, writing 1 has no effect.

Bit 14 **DTOG\_RX**: Data Toggle, for reception transfers

If the endpoint is not Isochronous, this bit contains the expected value of the data toggle bit (0=DATA0, 1=DATA1) for the next data packet to be received. Hardware toggles this bit, when the ACK handshake is sent to the USB host, following a data packet reception having a matching data PID value; if the endpoint is defined as a control one, hardware clears this bit at the reception of a SETUP PID addressed to this endpoint.

If the endpoint is using the double-buffering feature this bit is used to support packet buffer swapping too (Refer to [Section 22.4.3: Double-buffered endpoints](#)).

If the endpoint is Isochronous, this bit is used only to support packet buffer swapping since no data toggling is used for this sort of endpoints and only DATA0 packet are transmitted (Refer to [Section 22.4.4: Isochronous transfers](#)). Hardware toggles this bit just after the end of data packet reception, since no handshake is used for isochronous transfers.

This bit can also be toggled by the software to initialize its value (mandatory when the endpoint is not a control one) or to force specific data toggle/packet buffer usage. When the application software writes '0', the value of DTOG\_RX remains unchanged, while writing '1' makes the bit value toggle. This bit is read/write but it can be only toggled by writing 1.

Bits 13:12 **STAT\_RX [1:0]**: Status bits, for reception transfers

These bits contain information about the endpoint status, which are listed in [Table 170: Reception status encoding on page 603](#). These bits can be toggled by software to initialize their value. When the application software writes '0', the value remains unchanged, while writing '1' makes the bit value toggle. Hardware sets the STAT\_RX bits to NAK when a correct transfer has occurred (CTR\_RX=1) corresponding to a OUT or SETUP (control only) transaction addressed to this endpoint, so the software has the time to elaborate the received data before it acknowledge a new transaction

Double-buffered bulk endpoints implement a special transaction flow control, which control the status based upon buffer availability condition (Refer to [Section 22.4.3: Double-buffered endpoints](#)).

If the endpoint is defined as Isochronous, its status can be only "VALID" or "DISABLED", so that the hardware cannot change the status of the endpoint after a successful transaction. If the software sets the STAT\_RX bits to 'STALL' or 'NAK' for an Isochronous endpoint, the USB peripheral behavior is not defined. These bits are read/write but they can be only toggled by writing '1'.

**Bit 11 SETUP:** Setup transaction completed

This bit is read-only and it is set by the hardware when the last completed transaction is a SETUP. This bit changes its value only for control endpoints. It must be examined, in the case of a successful receive transaction (CTR\_RX event), to determine the type of transaction occurred. To protect the interrupt service routine from the changes in SETUP bits due to next incoming tokens, this bit is kept frozen while CTR\_RX bit is at 1; its state changes when CTR\_RX is at 0. This bit is read-only.

**Bits 10:9 EP\_TYPE[1:0]:** Endpoint type

These bits configure the behavior of this endpoint as described in [Table 171: Endpoint type encoding on page 603](#). Endpoint 0 must always be a control endpoint and each USB function must have at least one control endpoint which has address 0, but there may be other control endpoints if required. Only control endpoints handle SETUP transactions, which are ignored by endpoints of other kinds. SETUP transactions cannot be answered with NAK or STALL. If a control endpoint is defined as NAK, the USB peripheral will not answer, simulating a receive error, in the receive direction when a SETUP transaction is received. If the control endpoint is defined as STALL in the receive direction, then the SETUP packet will be accepted anyway, transferring data and issuing the CTR interrupt. The reception of OUT transactions is handled in the normal way, even if the endpoint is a control one.

Bulk and interrupt endpoints have very similar behavior and they differ only in the special feature available using the EP\_KIND configuration bit.

The usage of Isochronous endpoints is explained in [Section 22.4.4: Isochronous transfers](#)

**Bit 8 EP\_KIND:** Endpoint kind

The meaning of this bit depends on the endpoint type configured by the EP\_TYPE bits. [Table 172](#) summarizes the different meanings.

**DBL\_BUF:** This bit is set by the software to enable the double-buffering feature for this bulk endpoint. The usage of double-buffered bulk endpoints is explained in [Section 22.4.3: Double-buffered endpoints](#).

**STATUS\_OUT:** This bit is set by the software to indicate that a status out transaction is expected: in this case all OUT transactions containing more than zero data bytes are answered 'STALL' instead of 'ACK'. This bit may be used to improve the robustness of the application to protocol errors during control transfers and its usage is intended for control endpoints only. When STATUS\_OUT is reset, OUT transactions can have any number of bytes, as required.

**Bit 7 CTR\_TX:** Correct Transfer for transmission

This bit is set by the hardware when an IN transaction is successfully completed on this endpoint; the software can only clear this bit. If the CTRM bit in the USB\_CNTR register is set accordingly, a generic interrupt condition is generated together with the endpoint related interrupt condition, which is always activated.

A transaction ended with a NAK or STALL handshake does not set this bit, since no data is actually transferred, as in the case of protocol errors or data toggle mismatches.

This bit is read/write but only '0' can be written.

Bit 6 **DTOG\_TX**: Data Toggle, for transmission transfers

If the endpoint is non-isochronous, this bit contains the required value of the data toggle bit (0=DATA0, 1=DATA1) for the next data packet to be transmitted. Hardware toggles this bit when the ACK handshake is received from the USB host, following a data packet transmission. If the endpoint is defined as a control one, hardware sets this bit to 1 at the reception of a SETUP PID addressed to this endpoint.

If the endpoint is using the double buffer feature, this bit is used to support packet buffer swapping too (Refer to [Section 22.4.3: Double-buffered endpoints](#))

If the endpoint is Isochronous, this bit is used to support packet buffer swapping since no data toggling is used for this sort of endpoints and only DATA0 packet are transmitted (Refer to [Section 22.4.4: Isochronous transfers](#)). Hardware toggles this bit just after the end of data packet transmission, since no handshake is used for Isochronous transfers.

This bit can also be toggled by the software to initialize its value (mandatory when the endpoint is not a control one) or to force a specific data toggle/packet buffer usage. When the application software writes '0, the value of DTOG\_TX remains unchanged, while writing '1 makes the bit value toggle. This bit is read/write but it can only be toggled by writing 1.

Bits 5:4 **STAT\_TX [1:0]**: Status bits, for transmission transfers

These bits contain the information about the endpoint status, listed in [Table 173](#). These bits can be toggled by the software to initialize their value. When the application software writes '0, the value remains unchanged, while writing '1 makes the bit value toggle. Hardware sets the STAT\_TX bits to NAK, when a correct transfer has occurred (CTR\_TX=1) corresponding to a IN or SETUP (control only) transaction addressed to this endpoint. It then waits for the software to prepare the next set of data to be transmitted.

Double-buffered bulk endpoints implement a special transaction flow control, which controls the status based on buffer availability condition (Refer to [Section 22.4.3: Double-buffered endpoints](#)).

If the endpoint is defined as Isochronous, its status can only be "VALID" or "DISABLED".

Therefore, the hardware cannot change the status of the endpoint after a successful transaction. If the software sets the STAT\_TX bits to 'STALL' or 'NAK' for an Isochronous endpoint, the USB peripheral behavior is not defined. These bits are read/write but they can be only toggled by writing '1.

Bits 3:0 **EA[3:0]**: Endpoint address

Software must write in this field the 4-bit address used to identify the transactions directed to this endpoint. A value must be written before enabling the corresponding endpoint.

**Table 170. Reception status encoding**

STAT_RX[1:0]	Meaning
00	<b>DISABLED</b> : all reception requests addressed to this endpoint are ignored.
01	<b>STALL</b> : the endpoint is stalled and all reception requests result in a STALL handshake.
10	<b>NAK</b> : the endpoint is naked and all reception requests result in a NAK handshake.
11	<b>VALID</b> : this endpoint is enabled for reception.

**Table 171. Endpoint type encoding**

EP_TYPE[1:0]	Meaning
00	BULK
01	CONTROL

**Table 171. Endpoint type encoding (continued)**

EP_TYPE[1:0]	Meaning
10	ISO
11	INTERRUPT

**Table 172. Endpoint kind meaning**

EP_TYPE[1:0]	EP_KIND	Meaning
00	BULK	DBL_BUF
01	CONTROL	STATUS_OUT
10	ISO	Not used
11	INTERRUPT	Not used

**Table 173. Transmission status encoding**

STAT_TX[1:0]	Meaning
00	<b>DISABLED:</b> all transmission requests addressed to this endpoint are ignored.
01	<b>STALL:</b> the endpoint is stalled and all transmission requests result in a STALL handshake.
10	<b>NAK:</b> the endpoint is naked and all transmission requests result in a NAK handshake.
11	<b>VALID:</b> this endpoint is enabled for transmission.

### 22.5.3 Buffer descriptor table

Although the buffer descriptor table is located inside the packet buffer memory, its entries can be considered as additional registers used to configure the location and size of the packet buffers used to exchange data between the USB macro cell and the STM32F10xxx. Due to the common APB bridge limitation on word addressability, all packet memory locations are accessed by the APB using 32-bit aligned addresses, instead of the actual memory location addresses utilized by the USB peripheral for the USB\_BTABLE register and buffer description table locations.

In the following pages two location addresses are reported: the one to be used by application software while accessing the packet memory, and the local one relative to USB Peripheral access. To obtain the correct STM32F10xxx memory address value to be used in the application software while accessing the packet memory, the actual memory location address must be multiplied by two. The first packet memory location is located at 0x4000 6000. The buffer descriptor table entry associated with the USB\_EPnR registers is described below.

A thorough explanation of packet buffers and the buffer descriptor table usage can be found in [Structure and usage of packet buffers on page 584](#).

**Transmission buffer address n (USB\_ADDRn\_TX)**

Address offset: [USB\_BTABLE] + n\*16

USB local address: [USB\_BTABLE] + n\*8

15	14	13	12	11	10	9	8	7	6	5	4	3	2	1	0	
ADDRn_TX[15:1]															-	
rw	rw	rw	rw	rw	rw	rw	rw	rw	rw	rw	rw	rw	rw	rw	rw	-

Bits 15:1 **ADDRn\_TX[15:1]**: Transmission buffer address

These bits point to the starting address of the packet buffer containing data to be transmitted by the endpoint associated with the USB\_EPnR register at the next IN token addressed to it.

Bit 0 Must always be written as '0 since packet memory is word-wide and all packet buffers must be word-aligned.

**Transmission byte count n (USB\_COUNTn\_TX)**

Address offset: [USB\_BTABLE] + n\*16 + 4

USB local Address: [USB\_BTABLE] + n\*8 + 2

15	14	13	12	11	10	9	8	7	6	5	4	3	2	1	0
-						COUNTn_TX[9:0]									
						rw	rw	rw	rw	rw	rw	rw	rw	rw	rw

Bits 15:10 These bits are not used since packet size is limited by USB specifications to 1023 bytes. Their value is not considered by the USB peripheral.

Bits 9:0 **COUNTn\_TX[9:0]**: Transmission byte count

These bits contain the number of bytes to be transmitted by the endpoint associated with the USB\_EPnR register at the next IN token addressed to it.

*Note: Double-buffered and Isochronous IN Endpoints have two USB\_COUNTn\_TX registers: named USB\_COUNTn\_TX\_1 and USB\_COUNTn\_TX\_0 with the following content.*

31	30	29	28	27	26	25	24	23	22	21	20	19	18	17	16
-						COUNTn_TX_1[9:0]									
						rw	rw	rw	rw	rw	rw	rw	rw	rw	rw
15	14	13	12	11	10	9	8	7	6	5	4	3	2	1	0
-						COUNTn_TX_0[9:0]									
						rw	rw	rw	rw	rw	rw	rw	rw	rw	rw

**Reception buffer address n (USB\_ADDRn\_RX)**

Address offset: [USB\_BTABLE] + n\*16 + 8

USB local Address: [USB\_BTABLE] + n\*8 + 4

15	14	13	12	11	10	9	8	7	6	5	4	3	2	1	0	
ADDRn_RX[15:1]															-	
rw	rw	rw	rw	rw	rw	rw	rw	rw	rw	rw	rw	rw	rw	rw	rw	-

Bits 15:1 **ADDRn\_RX[15:1]**: Reception buffer address

These bits point to the starting address of the packet buffer, which will contain the data received by the endpoint associated with the USB\_EPnR register at the next OUT/SETUP token addressed to it.

Bit 0 This bit must always be written as '0 since packet memory is word-wide and all packet buffers must be word-aligned.

**Reception byte count n (USB\_COUNTn\_RX)**

Address offset: [USB\_BTABLE] + n\*16 + 12

USB local Address: [USB\_BTABLE] + n\*8 + 6

15	14	13	12	11	10	9	8	7	6	5	4	3	2	1	0
BLSIZE	NUM_BLOCK[4:0]					COUNTn_RX[9:0]									
rw	rw	rw	rw	rw	rw	r	r	r	r	r	r	r	r	r	r

This table location is used to store two different values, both required during packet reception. The most significant bits contains the definition of allocated buffer size, to allow buffer overflow detection, while the least significant part of this location is written back by the USB peripheral at the end of reception to give the actual number of received bytes. Due to the restrictions on the number of available bits, buffer size is represented using the number of allocated memory blocks, where block size can be selected to choose the trade-off between fine-granularity/small-buffer and coarse-granularity/large-buffer. The size of allocated buffer is a part of the endpoint descriptor and it is normally defined during the enumeration process according to its maxPacketSize parameter value (See "Universal Serial Bus Specification").

Bit 15 **BL\_SIZE**: BLock size

This bit selects the size of memory block used to define the allocated buffer area.

- If BL\_SIZE=0, the memory block is 2 byte large, which is the minimum block allowed in a word-wide memory. With this block size the allocated buffer size ranges from 2 to 62 bytes.
- If BL\_SIZE=1, the memory block is 32 byte large, which allows to reach the maximum packet length defined by USB specifications. With this block size the allocated buffer size ranges from 32 to 1024 bytes, which is the longest packet size allowed by USB standard specifications.

Bits 14:10 **NUM\_BLOCK[4:0]**: Number of blocks

These bits define the number of memory blocks allocated to this packet buffer. The actual amount of allocated memory depends on the BL\_SIZE value as illustrated in [Table 174](#).

Bits 9:0 **COUNTn\_RX[9:0]**: Reception byte count

These bits contain the number of bytes received by the endpoint associated with the USB\_EPnR register during the last OUT/SETUP transaction addressed to it.

*Note: Double-buffered and Isochronous IN Endpoints have two USB\_COUNTn\_TX registers: named USB\_COUNTn\_TX\_1 and USB\_COUNTn\_TX\_0 with the following content.*

	31	30	29	28	27	26	25	24	23	22	21	20	19	18	17	16
BLSIZE _1	NUM_BLOCK_1[4:0]					COUNTn_RX_1[9:0]										
rw	rw	rw	rw	rw	rw	r	r	r	r	r	r	r	r	r	r	r
15	14	13	12	11	10	9	8	7	6	5	4	3	2	1	0	
BLSIZE _0	NUM_BLOCK_0[4:0]					COUNTn_RX_0[9:0]										
rw	rw	rw	rw	rw	rw	r	r	r	r	r	r	r	r	r	r	r

**Table 174. Definition of allocated buffer memory**

Value of NUM_BLOCK[4:0]	Memory allocated when BL_SIZE=0	Memory allocated when BL_SIZE=1
0 ('00000)	Not allowed	32 bytes
1 ('00001)	2 bytes	64 bytes
2 ('00010)	4 bytes	96 bytes
3 ('00011)	6 bytes	128 bytes
...	...	...
15 ('01111)	30 bytes	512 bytes
16 ('10000)	32 bytes	N/A
17 ('10001)	34 bytes	N/A
18 ('10010)	36 bytes	N/A
...	...	...
30 ('11110)	60 bytes	N/A
31 ('11111)	62 bytes	N/A

### 22.5.4 USB register map

The table below provides the USB register map and reset values.

**Table 175. USB register map and reset values**

Offset	Register	31	30	29	28	27	26	25	24	23	22	21	20	19	18	17	16	15	14	13	12	11	10	9	8	7	6	5	4	3	2	1	0																		
0x00	<b>USB_EP0R</b>	Reserved																CTR_RX	DTOG_RX	STAT_RX [1:0]	SETUP	EP_TYPE [1:0]	EP_KIND	CTR_TX	DTOG_TX	STAT_TX [1:0]	EA[3:0]																								
	Reset value																	0	0	0	0	0	0	0	0	0	0	0	0	0	0	0	0	0	0	0	0	0	0	0	0	0	0	0	0						
0x04	<b>USB_EP1R</b>	Reserved																CTR_RX	DTOG_RX	STAT_RX [1:0]	SETUP	EP_TYPE [1:0]	EP_KIND	CTR_TX	DTOG_TX	STAT_TX [1:0]	EA[3:0]																								
	Reset value																	0	0	0	0	0	0	0	0	0	0	0	0	0	0	0	0	0	0	0	0	0	0	0	0	0	0	0	0	0	0				
0x08	<b>USB_EP2R</b>	Reserved																CTR_RX	DTOG_RX	STAT_RX [1:0]	SETUP	EP_TYPE [1:0]	EP_KIND	CTR_TX	DTOG_TX	STAT_TX [1:0]	EA[3:0]																								
	Reset value																	0	0	0	0	0	0	0	0	0	0	0	0	0	0	0	0	0	0	0	0	0	0	0	0	0	0	0	0	0	0	0			
0x0C	<b>USB_EP3R</b>	Reserved																CTR_RX	DTOG_RX	STAT_RX [1:0]	SETUP	EP_TYPE [1:0]	EP_KIND	CTR_TX	DTOG_TX	STAT_TX [1:0]	EA[3:0]																								
	Reset value																	0	0	0	0	0	0	0	0	0	0	0	0	0	0	0	0	0	0	0	0	0	0	0	0	0	0	0	0	0	0	0	0		
0x10	<b>USB_EP4R</b>	Reserved																CTR_RX	DTOG_RX	STAT_RX [1:0]	SETUP	EP_TYPE [1:0]	EP_KIND	CTR_TX	DTOG_TX	STAT_TX [1:0]	EA[3:0]																								
	Reset value																	0	0	0	0	0	0	0	0	0	0	0	0	0	0	0	0	0	0	0	0	0	0	0	0	0	0	0	0	0	0	0	0	0	
0x14	<b>USB_EP5R</b>	Reserved																CTR_RX	DTOG_RX	STAT_RX [1:0]	SETUP	EP_TYPE [1:0]	EP_KIND	CTR_TX	DTOG_TX	STAT_TX [1:0]	EA[3:0]																								
	Reset value																	0	0	0	0	0	0	0	0	0	0	0	0	0	0	0	0	0	0	0	0	0	0	0	0	0	0	0	0	0	0	0	0	0	0
0x18	<b>USB_EP6R</b>	Reserved																CTR_RX	DTOG_RX	STAT_RX [1:0]	SETUP	EP_TYPE [1:0]	EP_KIND	CTR_TX	DTOG_TX	STAT_TX [1:0]	EA[3:0]																								
	Reset value																	0	0	0	0	0	0	0	0	0	0	0	0	0	0	0	0	0	0	0	0	0	0	0	0	0	0	0	0	0	0	0	0	0	0
0x1C	<b>USB_EP7R</b>	Reserved																CTR_RX	DTOG_RX	STAT_RX [1:0]	SETUP	EP_TYPE [1:0]	EP_KIND	CTR_TX	DTOG_TX	STAT_TX [1:0]	EA[3:0]																								
	Reset value																	0	0	0	0	0	0	0	0	0	0	0	0	0	0	0	0	0	0	0	0	0	0	0	0	0	0	0	0	0	0	0	0	0	0
0x20-0x3F	Reserved																																																		
0x40	<b>USB_CNTR</b>	Reserved																CTRM	PMAOVRM	ERRM	WKUPM	SUSPM	RESETM	SOFM	ESOFM	Reserved							RESUME	FSUSP	LPMODE	PDWN	FRES														
	Reset value																	0	0	0	0	0	0	0	0								0	0	0	1	1														
0x44	<b>USB_ISTR</b>	Reserved																CTR	PMAOVR	ERR	WKUP	SUSP	RESET	SOF	ESOF	Reserved							DIR	EP_ID[3:0]																	
	Reset value																	0	0	0	0	0	0	0	0								0	0	0	0	0	0	0	0	0										
0x48	<b>USB_FNR</b>	Reserved																RXDP	RXDM	LCK	LSOF [1:0]	FN[10:0]																													
	Reset value																	0	0	0	0	0	x	x	x	x	x	x	x	x	x	x	x	x	x	x	x	x	x	x	x	x	x	x	x	x	x	x			
0x4C	<b>USB_DADDR</b>	Reserved																Reserved							EF	ADD[6:0]																									
	Reset value																								0	0	0	0	0	0	0	0	0	0	0	0	0	0	0	0	0	0	0	0	0	0					





**Table 175. USB register map and reset values (continued)**

Offset	Register	31	30	29	28	27	26	25	24	23	22	21	20	19	18	17	16	15	14	13	12	11	10	9	8	7	6	5	4	3	2	1	0					
0x50	USB_BTABLE	Reserved																BTABLE[15:3]										Reserved										
	Reset value																	0	0	0	0	0	0	0	0	0	0	0	0	0	0	0	0	0	0	0	0	

Note: Refer to [Table 1 on page 44](#) for the register boundary addresses.

## 23 Controller area network (bxCAN)

**Low-density devices** are STM32F101xx, STM32F102xx and STM32F103xx microcontrollers where the Flash memory density ranges between 16 and 32 Kbytes.

**Medium-density devices** are STM32F101xx, STM32F102xx and STM32F103xx microcontrollers where the Flash memory density ranges between 64 and 128 Kbytes.

**High-density devices** are STM32F101xx and STM32F103xx microcontrollers where the Flash memory density ranges between 256 and 512 Kbytes.

**XL-density devices** are STM32F101xx and STM32F103xx microcontrollers where the Flash memory density ranges between 768 Kbytes and 1 Mbyte.

**Connectivity line devices** are STM32F105xx and STM32F107xx microcontrollers.

This section applies to the connectivity line and STM32F103xx performance line only.

### 23.1 bxCAN introduction

The **Basic Extended CAN** peripheral, named **bxCAN**, interfaces the CAN network. It supports the CAN protocols version 2.0A and B. It has been designed to manage a high number of incoming messages efficiently with a minimum CPU load. It also meets the priority requirements for transmit messages.

For safety-critical applications, the CAN controller provides all hardware functions for supporting the CAN Time Triggered Communication option.

### 23.2 bxCAN main features

- Supports CAN protocol version 2.0 A, B Active
- Bit rates up to 1 Mbit/s
- Supports the Time Triggered Communication option

#### Transmission

- Three transmit mailboxes
- Configurable transmit priority
- Time Stamp on SOF transmission

#### Reception

- Two receive FIFOs with three stages
- Scalable filter banks:
  - 28 filter banks shared between CAN1 and CAN2 in connectivity line devices
  - 14 filter banks in other STM32F10xxx devices
- Identifier list feature
- Configurable FIFO overrun
- Time Stamp on SOF reception

**Time-triggered communication option**

- Disable automatic retransmission mode
- 16-bit free running timer
- Time Stamp sent in last two data bytes

**Management**

- Maskable interrupts
- Software-efficient mailbox mapping at a unique address space

**Dual CAN (connectivity line only)**

- CAN1: Master bxCAN for managing the communication between a Slave bxCAN and the 512-byte SRAM memory
- CAN2: Slave bxCAN, with no direct access to the SRAM memory.
- The two bxCAN cells share the 512-byte SRAM memory (see [Figure 222 on page 613](#))

*Note: In medium-, high- and XL-density devices the USB and CAN share a dedicated 512-byte SRAM memory for data transmission and reception, and so they cannot be used concurrently (the shared SRAM is accessed through CAN and USB exclusively). The USB and CAN can be used in the same application but not at the same time.*

### 23.3 bxCAN general description

In today's CAN applications, the number of nodes in a network is increasing and often several networks are linked together via gateways. Typically the number of messages in the system (and thus to be handled by each node) has significantly increased. In addition to the application messages, Network Management and Diagnostic messages have been introduced.

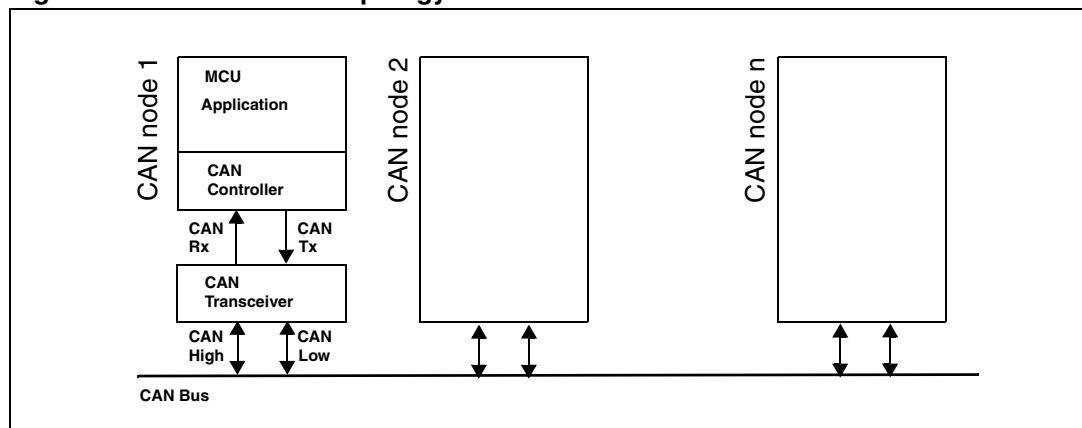
- An enhanced filtering mechanism is required to handle each type of message.

Furthermore, application tasks require more CPU time, therefore real-time constraints caused by message reception have to be reduced.

- A receive FIFO scheme allows the CPU to be dedicated to application tasks for a long time period without losing messages.

The standard HLP (Higher Layer Protocol) based on standard CAN drivers requires an efficient interface to the CAN controller.

**Figure 221. CAN network topology**



### 23.3.1 CAN 2.0B active core

The bxCAN module handles the transmission and the reception of CAN messages fully autonomously. Standard identifiers (11-bit) and extended identifiers (29-bit) are fully supported by hardware.

### 23.3.2 Control, status and configuration registers

The application uses these registers to:

- Configure CAN parameters, e.g. baud rate
- Request transmissions
- Handle receptions
- Manage interrupts
- Get diagnostic information

### 23.3.3 Tx mailboxes

Three transmit mailboxes are provided to the software for setting up messages. The transmission Scheduler decides which mailbox has to be transmitted first.

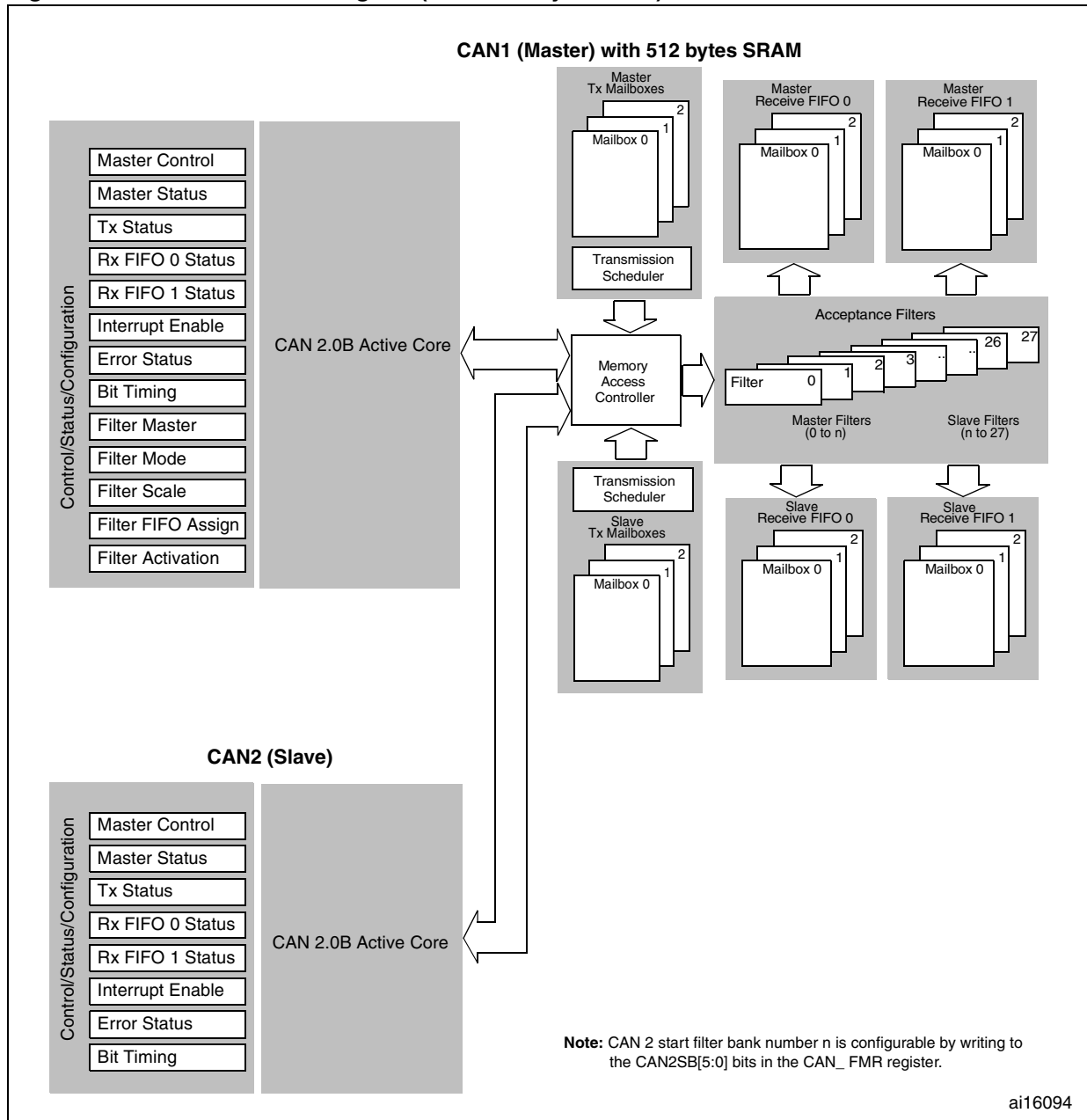
### 23.3.4 Acceptance filters

In Connectivity line devices the bxCAN provides 28 scalable/configurable identifier filter banks for selecting the incoming messages the software needs and discarding the others. In other devices there are 14 scalable/configurable identifier filter banks.

#### Receive FIFO

Two receive FIFOs are used by hardware to store the incoming messages. Three complete messages can be stored in each FIFO. The FIFOs are managed completely by hardware.

Figure 222. Dual CAN block diagram (connectivity devices)



### 23.4 bxCAN operating modes

bxCAN has three main operating modes: **initialization**, **normal** and **Sleep**. After a hardware reset, bxCAN is in Sleep mode to reduce power consumption and an internal pull-up is active on CANTX. The software requests bxCAN to enter **initialization** or **Sleep** mode by setting the INRQ or SLEEP bits in the CAN\_MCR register. Once the mode has been entered, bxCAN confirms it by setting the INAK or SLAK bits in the CAN\_MSR register and the internal pull-up is disabled. When neither INAK nor SLAK are set, bxCAN is in **normal** mode. Before entering **normal** mode bxCAN always has to **synchronize** on the CAN bus.

To synchronize, bxCAN waits until the CAN bus is idle, this means 11 consecutive recessive bits have been monitored on CANRX.

### 23.4.1 Initialization mode

The software initialization can be done while the hardware is in Initialization mode. To enter this mode the software sets the INRQ bit in the CAN\_MCR register and waits until the hardware has confirmed the request by setting the INAK bit in the CAN\_MSR register.

To leave Initialization mode, the software clears the INQR bit. bxCAN has left Initialization mode once the INAK bit has been cleared by hardware.

While in Initialization Mode, all message transfers to and from the CAN bus are stopped and the status of the CAN bus output CANTX is recessive (high).

Entering Initialization Mode does not change any of the configuration registers.

To initialize the CAN Controller, software has to set up the Bit Timing (CAN\_BTR) and CAN options (CAN\_MCR) registers.

To initialize the registers associated with the CAN filter banks (mode, scale, FIFO assignment, activation and filter values), software has to set the FINIT bit (CAN\_FMR). Filter initialization also can be done outside the initialization mode.

*Note:* When FINIT=1, CAN reception is deactivated.

*The filter values also can be modified by deactivating the associated filter activation bits (in the CAN\_FA1R register).*

*If a filter bank is not used, it is recommended to leave it non active (leave the corresponding FACT bit cleared).*

### 23.4.2 Normal mode

Once the initialization has been done, the software must request the hardware to enter Normal mode, to synchronize on the CAN bus and start reception and transmission. Entering Normal mode is done by clearing the INRQ bit in the CAN\_MCR register and waiting until the hardware has confirmed the request by clearing the INAK bit in the CAN\_MSR register. Afterwards, the bxCAN synchronizes with the data transfer on the CAN bus by waiting for the occurrence of a sequence of 11 consecutive recessive bits (≡ Bus Idle) before it can take part in bus activities and start message transfer.

The initialization of the filter values is independent from Initialization Mode but must be done while the filter is not active (corresponding FACTx bit cleared). The filter scale and mode configuration must be configured before entering Normal Mode.

### 23.4.3 Sleep mode (low power)

To reduce power consumption, bxCAN has a low-power mode called Sleep mode. This mode is entered on software request by setting the SLEEP bit in the CAN\_MCR register. In this mode, the bxCAN clock is stopped, however software can still access the bxCAN mailboxes.

If software requests entry to **initialization** mode by setting the INRQ bit while bxCAN is in **Sleep** mode, it must also clear the SLEEP bit.

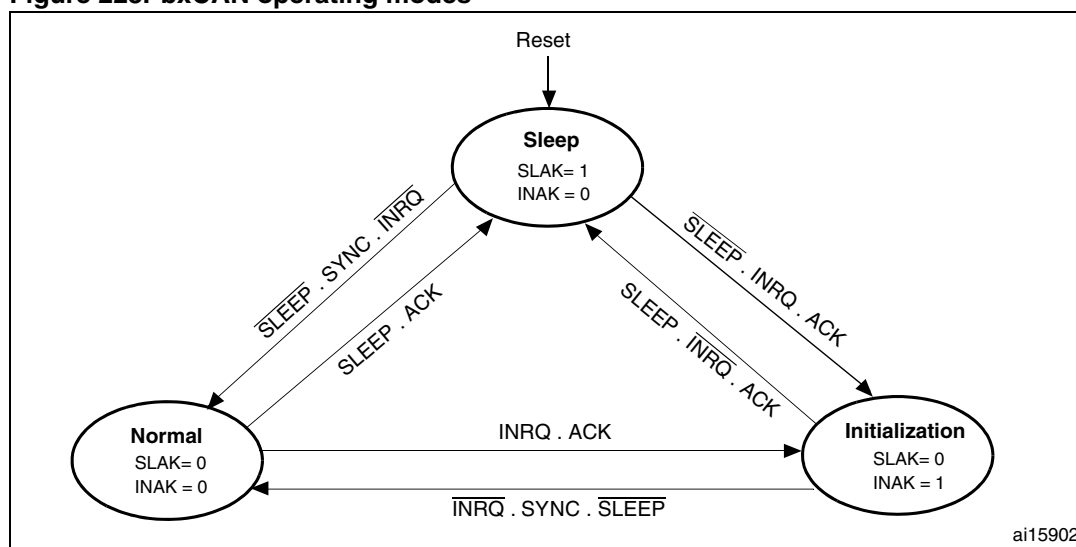
bxCAN can be woken up (exit Sleep mode) either by software clearing the SLEEP bit or on detection of CAN bus activity.

On CAN bus activity detection, hardware automatically performs the wakeup sequence by clearing the SLEEP bit if the AWUM bit in the CAN\_MCR register is set. If the AWUM bit is cleared, software has to clear the SLEEP bit when a wakeup interrupt occurs, in order to exit from Sleep mode.

*Note:* If the wakeup interrupt is enabled (WKUIE bit set in CAN\_IER register) a wakeup interrupt will be generated on detection of CAN bus activity, even if the bxCAN automatically performs the wakeup sequence.

After the SLEEP bit has been cleared, Sleep mode is exited once bxCAN has synchronized with the CAN bus, refer to [Figure 223: bxCAN operating modes](#). The Sleep mode is exited once the SLAK bit has been cleared by hardware.

**Figure 223. bxCAN operating modes**



1. ACK = The wait state during which hardware confirms a request by setting the INAK or SLAK bits in the CAN\_MSR register
2. SYNC = The state during which bxCAN waits until the CAN bus is idle, meaning 11 consecutive recessive bits have been monitored on CANRX

## 23.5 Test mode

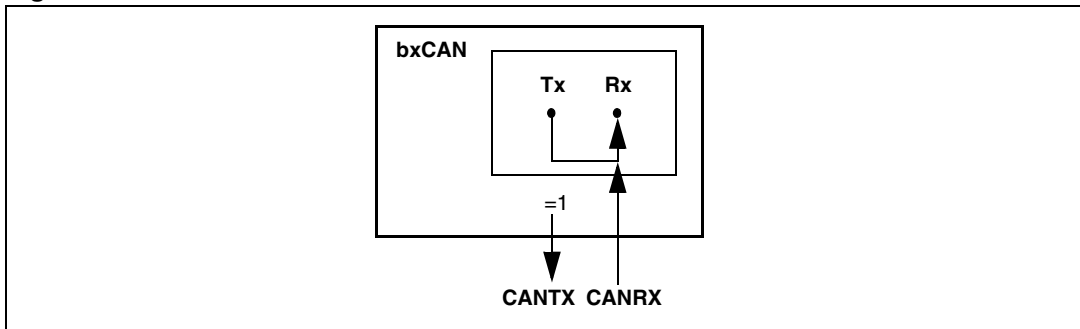
Test mode can be selected by the SILM and LBKM bits in the CAN\_BTR register. These bits must be configured while bxCAN is in Initialization mode. Once test mode has been selected, the INRQ bit in the CAN\_MCR register must be reset to enter Normal mode.

### 23.5.1 Silent mode

The bxCAN can be put in Silent mode by setting the SILM bit in the CAN\_BTR register.

In Silent mode, the bxCAN is able to receive valid data frames and valid remote frames, but it sends only recessive bits on the CAN bus and it cannot start a transmission. If the bxCAN has to send a dominant bit (ACK bit, overload flag, active error flag), the bit is rerouted internally so that the CAN Core monitors this dominant bit, although the CAN bus may remain in recessive state. Silent mode can be used to analyze the traffic on a CAN bus without affecting it by the transmission of dominant bits (Acknowledge Bits, Error Frames).

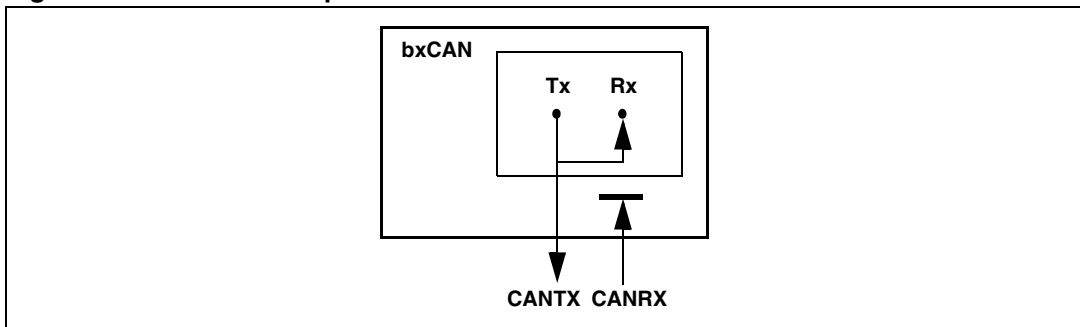
Figure 224. bxCAN in silent mode



### 23.5.2 Loop back mode

The bxCAN can be set in Loop Back Mode by setting the LBKM bit in the CAN\_BTR register. In Loop Back Mode, the bxCAN treats its own transmitted messages as received messages and stores them (if they pass acceptance filtering) in a Receive mailbox.

Figure 225. bxCAN in loop back mode



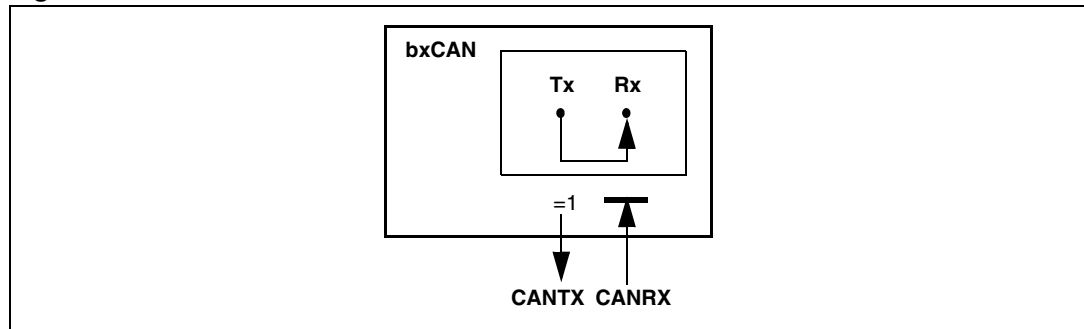
This mode is provided for self-test functions. To be independent of external events, the CAN Core ignores acknowledge errors (no dominant bit sampled in the acknowledge slot of a data / remote frame) in Loop Back Mode. In this mode, the bxCAN performs an internal feedback from its Tx output to its Rx input. The actual value of the CANRX input pin is disregarded by the bxCAN. The transmitted messages can be monitored on the CANTX pin.

### 23.5.3 Loop back combined with silent mode

It is also possible to combine Loop Back mode and Silent mode by setting the LBKM and SILM bits in the CAN\_BTR register. This mode can be used for a “Hot Selftest”, meaning the bxCAN can be tested like in Loop Back mode but without affecting a running CAN system connected to the CANTX and CANRX pins. In this mode, the CANRX pin is disconnected from the bxCAN and the CANTX pin is held recessive.



Figure 226. bxCAN in combined mode



## 23.6 STM32F10xxx in Debug mode

When the microcontroller enters the debug mode (Cortex-M3 core halted), the bxCAN continues to work normally or stops, depending on:

- the DBG\_CAN1\_STOP bit for CAN1 or the DBG\_CAN2\_STOP bit for CAN2 in the DBG module. For more details, refer to [Section 30.16.2: Debug support for timers, watchdog, bxCAN and I2C](#).
- the DBF bit in CAN\_MCR. For more details, refer to [Section 23.9.2: CAN control and status registers](#).

## 23.7 bxCAN functional description

### 23.7.1 Transmission handling

In order to transmit a message, the application must select one **empty** transmit mailbox, set up the identifier, the data length code (DLC) and the data before requesting the transmission by setting the corresponding TXRQ bit in the CAN\_TlRxR register. Once the mailbox has left **empty** state, the software no longer has write access to the mailbox registers. Immediately after the TXRQ bit has been set, the mailbox enters **pending** state and waits to become the highest priority mailbox, see *Transmit Priority*. As soon as the mailbox has the highest priority it will be **scheduled** for transmission. The transmission of the message of the scheduled mailbox will start (enter **transmit** state) when the CAN bus becomes idle. Once the mailbox has been successfully transmitted, it will become **empty** again. The hardware indicates a successful transmission by setting the RQCP and TXOK bits in the CAN\_TSR register.

If the transmission fails, the cause is indicated by the ALST bit in the CAN\_TSR register in case of an Arbitration Lost, and/or the TERR bit, in case of transmission error detection.

#### Transmit priority

##### By identifier:

When more than one transmit mailbox is pending, the transmission order is given by the identifier of the message stored in the mailbox. The message with the lowest identifier value has the highest priority according to the arbitration of the CAN protocol. If the identifier values are equal, the lower mailbox number will be scheduled first.

##### By transmit request order:

The transmit mailboxes can be configured as a transmit FIFO by setting the TXFP bit in the CAN\_MCR register. In this mode the priority order is given by the transmit request order.

This mode is very useful for segmented transmission.

### Abort

A transmission request can be aborted by the user setting the ABRQ bit in the CAN\_TSR register. In **pending** or **scheduled** state, the mailbox is aborted immediately. An abort request while the mailbox is in **transmit** state can have two results. If the mailbox is transmitted successfully the mailbox becomes **empty** with the TXOK bit set in the CAN\_TSR register. If the transmission fails, the mailbox becomes **scheduled**, the transmission is aborted and becomes **empty** with TXOK cleared. In all cases the mailbox will become **empty** again at least at the end of the current transmission.

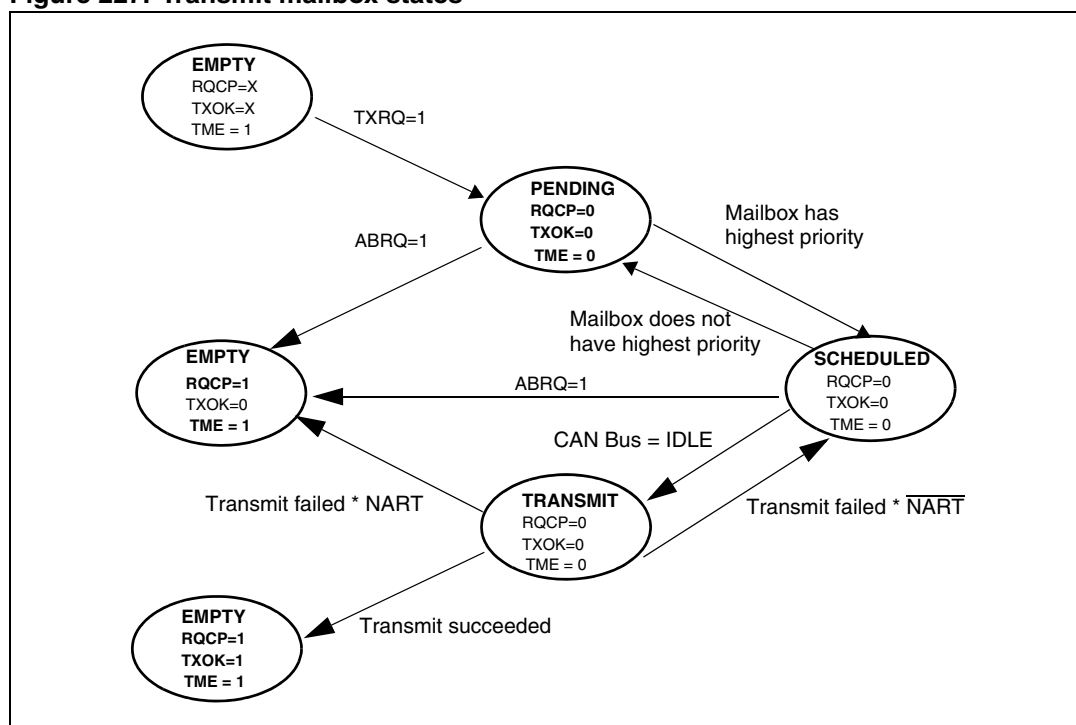
### Non-automatic retransmission mode

This mode has been implemented in order to fulfil the requirement of the Time Triggered Communication option of the CAN standard. To configure the hardware in this mode the NART bit in the CAN\_MCR register must be set.

In this mode, each transmission is started only once. If the first attempt fails, due to an arbitration loss or an error, the hardware will not automatically restart the message transmission.

At the end of the first transmission attempt, the hardware considers the request as completed and sets the RQCP bit in the CAN\_TSR register. The result of the transmission is indicated in the CAN\_TSR register by the TXOK, ALST and TERR bits.

Figure 227. Transmit mailbox states



### 23.7.2 Time triggered communication mode

In this mode, the internal counter of the CAN hardware is activated and used to generate the Time Stamp value stored in the CAN\_RDTxR/CAN\_TDTxR registers, respectively (for Rx and Tx mailboxes). The internal counter is incremented each CAN bit time (refer to [Section 23.7.7: Bit timing](#)). The internal counter is captured on the sample point of the Start Of Frame bit in both reception and transmission.

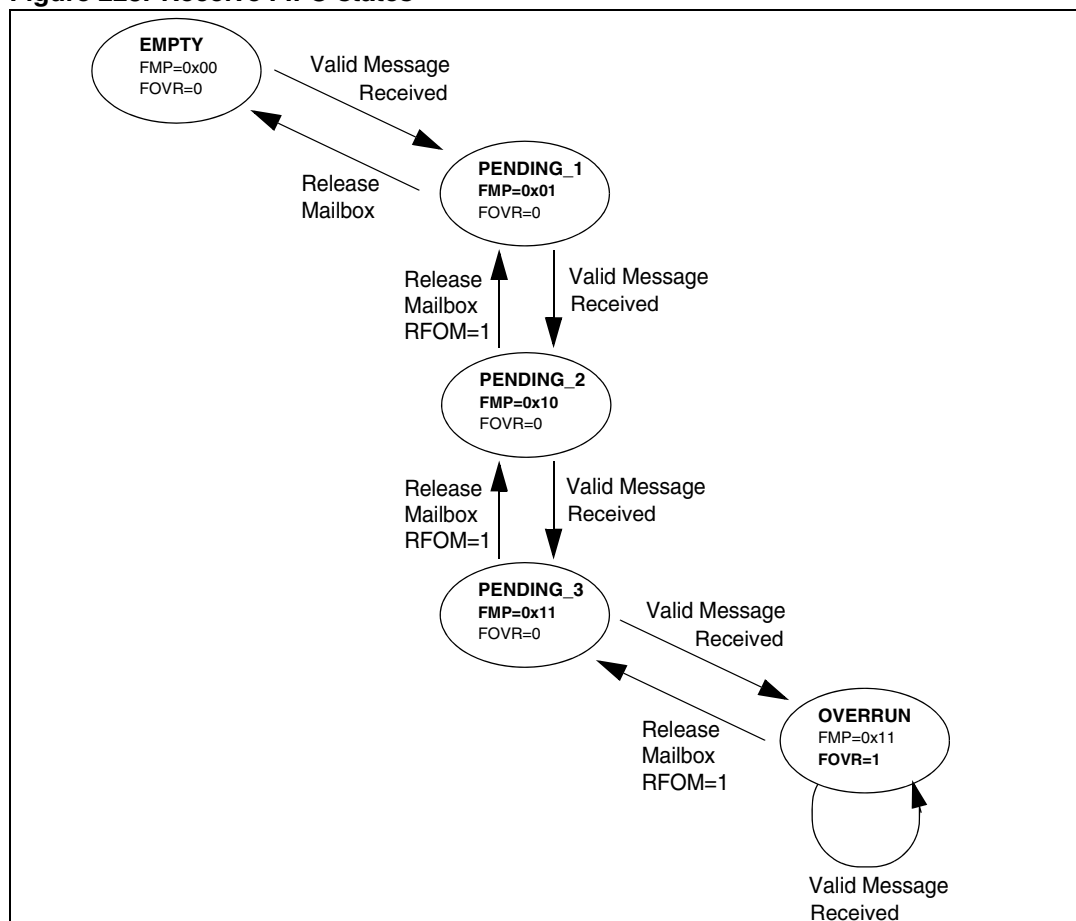
### 23.7.3 Reception handling

For the reception of CAN messages, three mailboxes organized as a FIFO are provided. In order to save CPU load, simplify the software and guarantee data consistency, the FIFO is managed completely by hardware. The application accesses the messages stored in the FIFO through the FIFO output mailbox.

#### Valid message

A received message is considered as valid **when** it has been received correctly according to the CAN protocol (no error until the last but one bit of the EOF field) **and** It passed through the identifier filtering successfully, see [Section 23.7.4: Identifier filtering](#).

Figure 228. Receive FIFO states



## FIFO management

Starting from the **empty** state, the first valid message received is stored in the FIFO which becomes **pending\_1**. The hardware signals the event setting the FMP[1:0] bits in the CAN\_RFR register to the value 01b. The message is available in the FIFO output mailbox. The software reads out the mailbox content and releases it by setting the RFOM bit in the CAN\_RFR register. The FIFO becomes **empty** again. If a new valid message has been received in the meantime, the FIFO stays in **pending\_1** state and the new message is available in the output mailbox.

If the application does not release the mailbox, the next valid message will be stored in the FIFO which enters **pending\_2** state (FMP[1:0] = 10b). The storage process is repeated for the next valid message putting the FIFO into **pending\_3** state (FMP[1:0] = 11b). At this point, the software must release the output mailbox by setting the RFOM bit, so that a mailbox is free to store the next valid message. Otherwise the next valid message received will cause a loss of message.

Refer also to [Section 23.7.5: Message storage](#)

## Overrun

Once the FIFO is in **pending\_3** state (i.e. the three mailboxes are full) the next valid message reception will lead to an **overrun** and a message will be lost. The hardware signals the overrun condition by setting the FOVR bit in the CAN\_RFR register. Which message is lost depends on the configuration of the FIFO:

- If the FIFO lock function is disabled (RFLM bit in the CAN\_MCR register cleared) the last message stored in the FIFO will be overwritten by the new incoming message. In this case the latest messages will be always available to the application.
- If the FIFO lock function is enabled (RFLM bit in the CAN\_MCR register set) the most recent message will be discarded and the software will have the three oldest messages in the FIFO available.

## Reception related interrupts

Once a message has been stored in the FIFO, the FMP[1:0] bits are updated and an interrupt request is generated if the FMPIE bit in the CAN\_IER register is set.

When the FIFO becomes full (i.e. a third message is stored) the FULL bit in the CAN\_RFR register is set and an interrupt is generated if the FFIE bit in the CAN\_IER register is set.

On overrun condition, the FOVR bit is set and an interrupt is generated if the FOVIE bit in the CAN\_IER register is set.

### 23.7.4 Identifier filtering

In the CAN protocol the identifier of a message is not associated with the address of a node but related to the content of the message. Consequently a transmitter broadcasts its message to all receivers. On message reception a receiver node decides - depending on the identifier value - whether the software needs the message or not. If the message is needed, it is copied into the SRAM. If not, the message must be discarded without intervention by the software.

To fulfill this requirement, in connectivity line devices the bxCAN Controller provides 28 configurable and scalable filter banks (27-0) to the application. In other devices the bxCAN Controller provides 14 configurable and scalable filter banks (13-0) to the application in order to receive only the messages the software needs. This hardware filtering saves CPU

resources which would be otherwise needed to perform filtering by software. Each filter bank *x* consists of two 32-bit registers, CAN\_FxR0 and CAN\_FxR1.

### Scalable width

To optimize and adapt the filters to the application needs, each filter bank can be scaled independently. Depending on the filter scale a filter bank provides:

- One 32-bit filter for the STDID[10:0], EXTID[17:0], IDE and RTR bits.
- Two 16-bit filters for the STDID[10:0], RTR, IDE and EXTID[17:15] bits.

Refer to [Figure 229](#).

Furthermore, the filters can be configured in mask mode or in identifier list mode.

### Mask mode

In **mask** mode the identifier registers are associated with mask registers specifying which bits of the identifier are handled as “must match” or as “don’t care”.

### Identifier list mode

In **identifier list** mode, the mask registers are used as identifier registers. Thus instead of defining an identifier and a mask, two identifiers are specified, doubling the number of single identifiers. All bits of the incoming identifier must match the bits specified in the filter registers.

### Filter bank scale and mode configuration

The filter banks are configured by means of the corresponding CAN\_FMR register. To configure a filter bank it must be deactivated by clearing the FACT bit in the CAN\_FAR register. The filter scale is configured by means of the corresponding FSCx bit in the CAN\_FS1R register, refer to [Figure 229](#). The **identifier list** or **identifier mask** mode for the corresponding Mask/Identifier registers is configured by means of the FBMx bits in the CAN\_FMR register.

To filter a group of identifiers, configure the Mask/Identifier registers in mask mode.

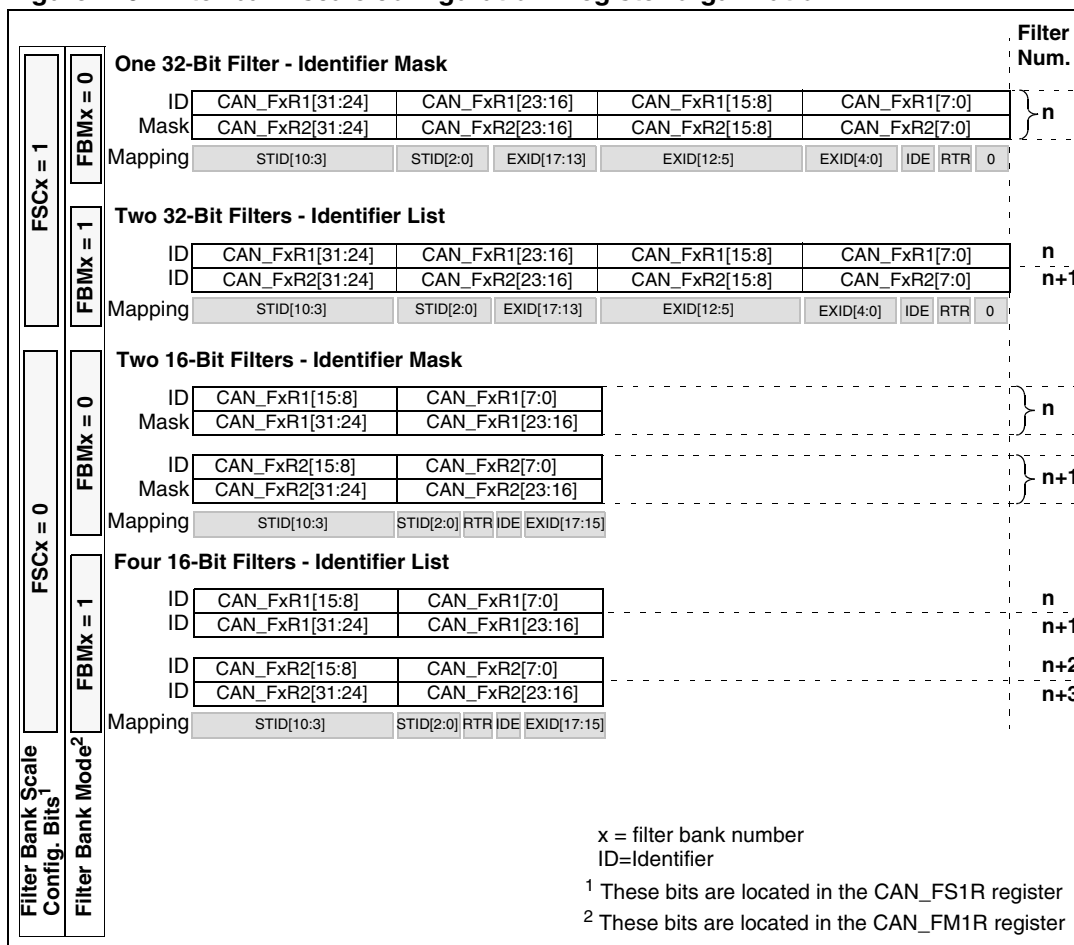
To select single identifiers, configure the Mask/Identifier registers in identifier list mode.

Filters not used by the application should be left deactivated.

Each filter within a filter bank is numbered (called the *Filter Number*) from 0 to a maximum dependent on the mode and the scale of each of the filter banks.

Concerning the filter configuration, refer to [Figure 229](#).

Figure 229. Filter bank scale configuration - register organization



**Filter match index**

Once a message has been received in the FIFO it is available to the application. Typically, application data is copied into SRAM locations. To copy the data to the right location the application has to identify the data by means of the identifier. To avoid this, and to ease the access to the SRAM locations, the CAN controller provides a Filter Match Index.

This index is stored in the mailbox together with the message according to the filter priority rules. Thus each received message has its associated filter match index.

The Filter Match index can be used in two ways:

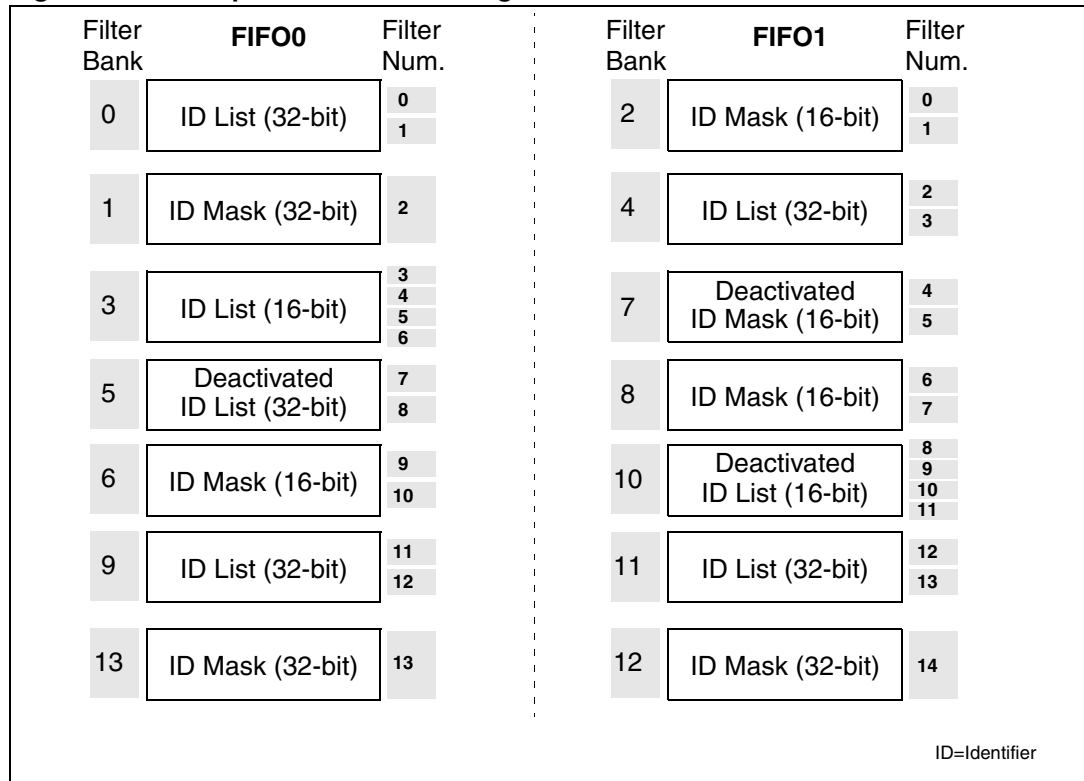
- Compare the Filter Match index with a list of expected values.
- Use the Filter Match Index as an index on an array to access the data destination location.

For non-masked filters, the software no longer has to compare the identifier.

If the filter is masked the software reduces the comparison to the masked bits only.

The index value of the filter number does not take into account the activation state of the filter banks. In addition, two independent numbering schemes are used, one for each FIFO. Refer to [Figure 230](#) for an example.

Figure 230. Example of filter numbering

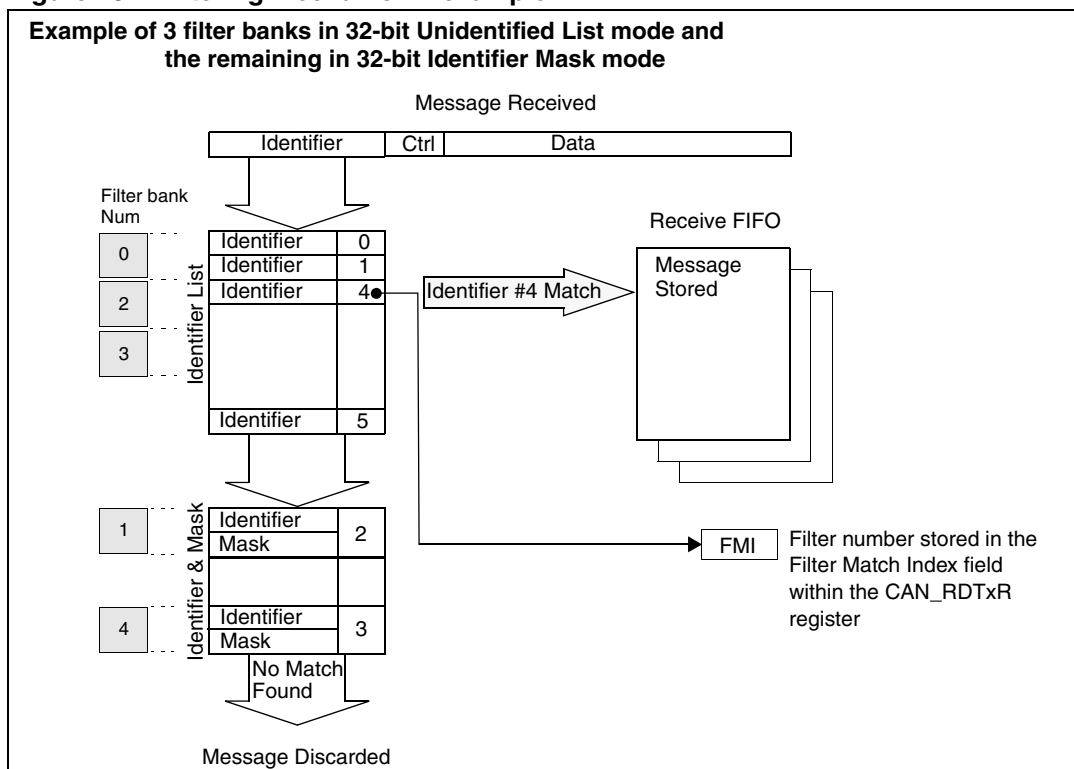


**Filter priority rules**

Depending on the filter combination it may occur that an identifier passes successfully through several filters. In this case the filter match value stored in the receive mailbox is chosen according to the following priority rules:

- A 32-bit filter takes priority over a 16-bit filter.
- For filters of equal scale, priority is given to the Identifier List mode over the Identifier Mask mode
- For filters of equal scale and mode, priority is given by the filter number (the lower the number, the higher the priority).

**Figure 231. Filtering mechanism - example**



The example above shows the filtering principle of the bxCAN. On reception of a message, the identifier is compared first with the filters configured in identifier list mode. If there is a match, the message is stored in the associated FIFO and the index of the matching filter is stored in the Filter Match Index. As shown in the example, the identifier matches with Identifier #2 thus the message content and FMI 2 is stored in the FIFO.

If there is no match, the incoming identifier is then compared with the filters configured in mask mode.

If the identifier does not match any of the identifiers configured in the filters, the message is discarded by hardware without disturbing the software.

### 23.7.5 Message storage

The interface between the software and the hardware for the CAN messages is implemented by means of mailboxes. A mailbox contains all information related to a message; identifier, data, control, status and time stamp information.

#### Transmit mailbox

The software sets up the message to be transmitted in an empty transmit mailbox. The status of the transmission is indicated by hardware in the CAN\_TSR register.



**Table 176. Transmit mailbox mapping**

Offset to transmit mailbox base address	Register name
0	CAN_TlRxR
4	CAN_TDTxR
8	CAN_TDLxR
12	CAN_TDHxR

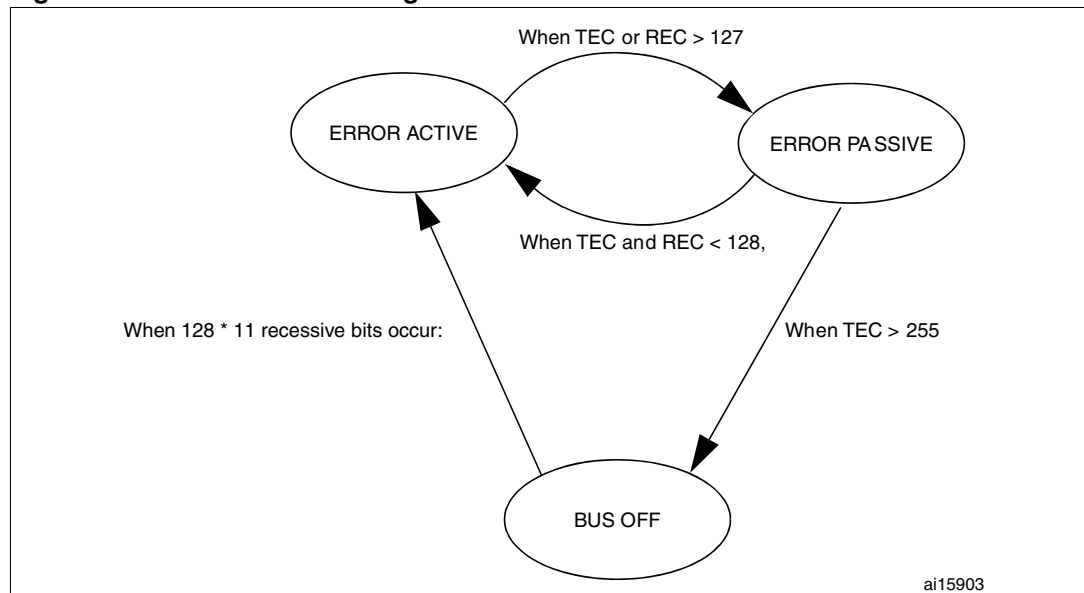
**Receive mailbox**

When a message has been received, it is available to the software in the FIFO output mailbox. Once the software has handled the message (e.g. read it) the software must release the FIFO output mailbox by means of the RFOM bit in the CAN\_RFR register to make the next incoming message available. The filter match index is stored in the MFMI field of the CAN\_RDTxR register. The 16-bit time stamp value is stored in the TIME[15:0] field of CAN\_RDTxR.

**Table 177. Receive mailbox mapping**

Offset to receive mailbox base address (bytes)	Register name
0	CAN_RlRxR
4	CAN_RDTxR
8	CAN_RDLxR
12	CAN_RDHxR

**Figure 232. CAN error state diagram**



### 23.7.6 Error management

The error management as described in the CAN protocol is handled entirely by hardware using a Transmit Error Counter (TEC value, in CAN\_ESR register) and a Receive Error Counter (REC value, in the CAN\_ESR register), which get incremented or decremented according to the error condition. For detailed information about TEC and REC management, please refer to the CAN standard.

Both of them may be read by software to determine the stability of the network. Furthermore, the CAN hardware provides detailed information on the current error status in CAN\_ESR register. By means of the CAN\_IER register (ERRIE bit, etc.), the software can configure the interrupt generation on error detection in a very flexible way.

#### Bus-Off recovery

The Bus-Off state is reached when TEC is greater than 255, this state is indicated by BOFF bit in CAN\_ESR register. In Bus-Off state, the bxCAN is no longer able to transmit and receive messages.

Depending on the ABOM bit in the CAN\_MCR register bxCAN will recover from Bus-Off (become error active again) either automatically or on software request. But in both cases the bxCAN has to wait at least for the recovery sequence specified in the CAN standard (128 occurrences of 11 consecutive recessive bits monitored on CANRX).

If ABOM is set, the bxCAN will start the recovering sequence automatically after it has entered Bus-Off state.

If ABOM is cleared, the software must initiate the recovering sequence by requesting bxCAN to enter and to leave initialization mode.

*Note:* In initialization mode, bxCAN does not monitor the CANRX signal, therefore it cannot complete the recovery sequence. **To recover, bxCAN must be in normal mode.**

### 23.7.7 Bit timing

The bit timing logic monitors the serial bus-line and performs sampling and adjustment of the sample point by synchronizing on the start-bit edge and resynchronizing on the following edges.

Its operation may be explained simply by splitting nominal bit time into three segments as follows:

- **Synchronization segment (SYNC\_SEG):** a bit change is expected to occur within this time segment. It has a fixed length of one time quantum ( $1 \times t_{CAN}$ ).
- **Bit segment 1 (BS1):** defines the location of the sample point. It includes the PROP\_SEG and PHASE\_SEG1 of the CAN standard. Its duration is programmable between 1 and 16 time quanta but may be automatically lengthened to compensate for positive phase drifts due to differences in the frequency of the various nodes of the network.
- **Bit segment 2 (BS2):** defines the location of the transmit point. It represents the PHASE\_SEG2 of the CAN standard. Its duration is programmable between 1 and 8 time quanta but may also be automatically shortened to compensate for negative phase drifts.

The resynchronization Jump Width (SJW) defines an upper bound to the amount of lengthening or shortening of the bit segments. It is programmable between 1 and 4 time quanta.

A valid edge is defined as the first transition in a bit time from dominant to recessive bus level provided the controller itself does not send a recessive bit.

If a valid edge is detected in BS1 instead of SYNC\_SEG, BS1 is extended by up to SJW so that the sample point is delayed.

Conversely, if a valid edge is detected in BS2 instead of SYNC\_SEG, BS2 is shortened by up to SJW so that the transmit point is moved earlier.

As a safeguard against programming errors, the configuration of the Bit Timing Register (CAN\_BTR) is only possible while the device is in Standby mode.

*Note: For a detailed description of the CAN bit timing and resynchronization mechanism, please refer to the ISO 11898 standard.*

**Figure 233. Bit timing**

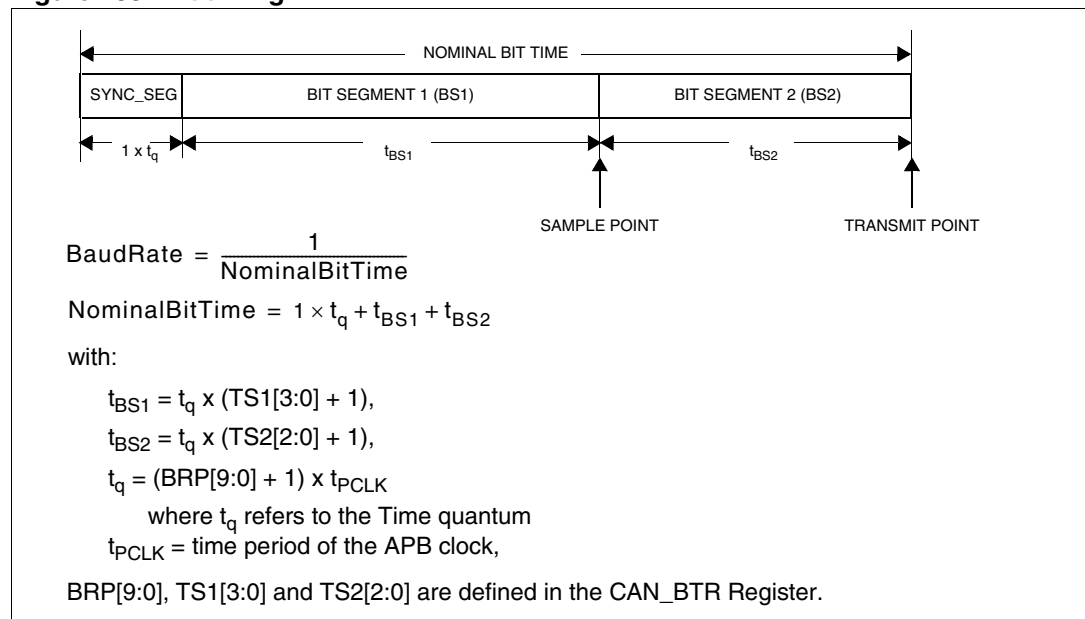
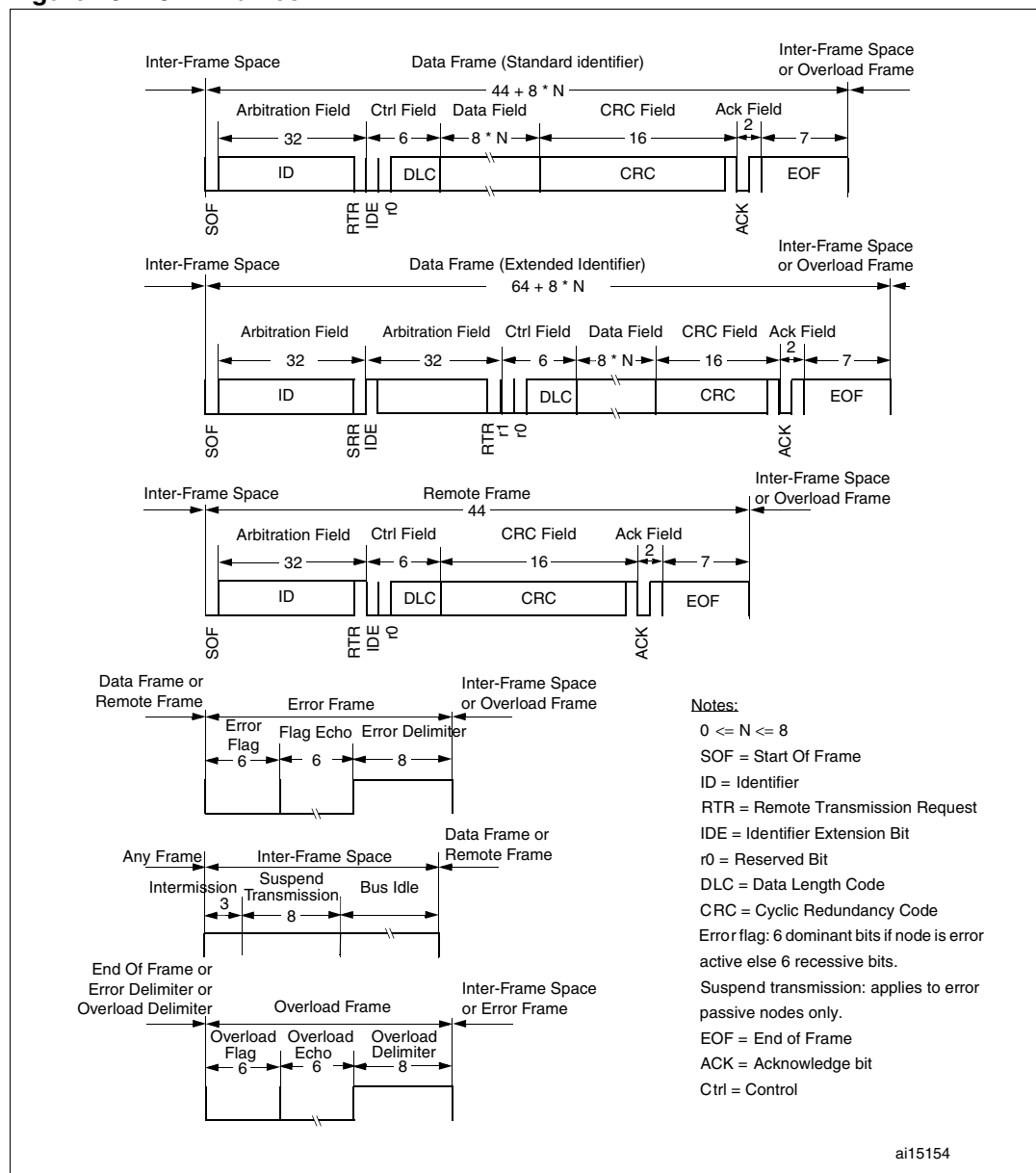


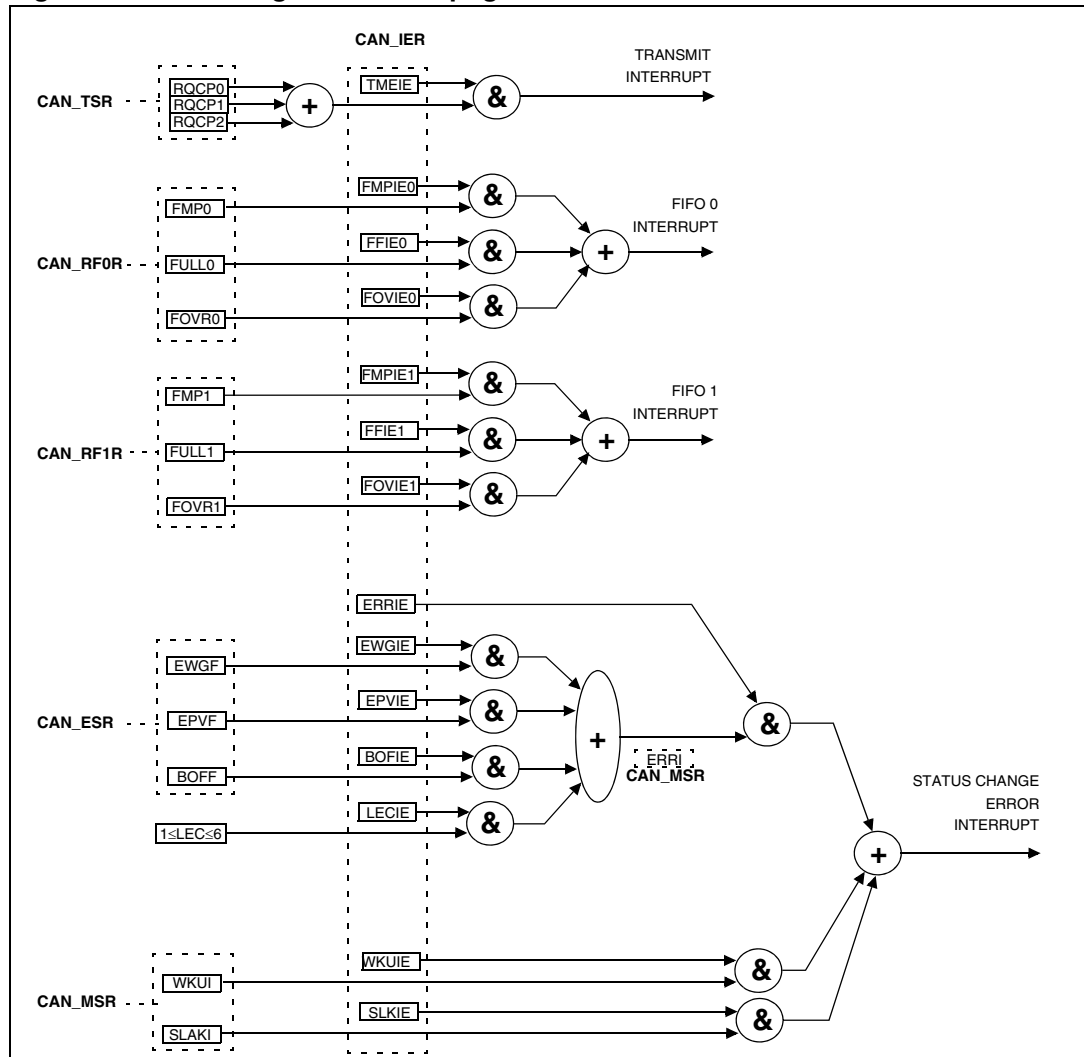
Figure 234. CAN frames



## 23.8 bxCAN interrupts

Four interrupt vectors are dedicated to bxCAN. Each interrupt source can be independently enabled or disabled by means of the CAN Interrupt Enable Register (CAN\_IER).

Figure 235. Event flags and interrupt generation



- The **transmit interrupt** can be generated by the following events:
  - Transmit mailbox 0 becomes empty, RQCP0 bit in the CAN\_TSR register set.
  - Transmit mailbox 1 becomes empty, RQCP1 bit in the CAN\_TSR register set.
  - Transmit mailbox 2 becomes empty, RQCP2 bit in the CAN\_TSR register set.
- The **FIFO 0 interrupt** can be generated by the following events:
  - Reception of a new message, FMP0 bits in the CAN\_RF0R register are not '00'.
  - FIFO0 full condition, FULL0 bit in the CAN\_RF0R register set.
  - FIFO0 overrun condition, FOVR0 bit in the CAN\_RF0R register set.
- The **FIFO 1 interrupt** can be generated by the following events:
  - Reception of a new message, FMP1 bits in the CAN\_RF1R register are not '00'.
  - FIFO1 full condition, FULL1 bit in the CAN\_RF1R register set.
  - FIFO1 overrun condition, FOVR1 bit in the CAN\_RF1R register set.

- The **error and status change interrupt** can be generated by the following events:
  - Error condition, for more details on error conditions please refer to the CAN Error Status register (CAN\_ESR).
  - Wakeup condition, SOF monitored on the CAN Rx signal.
  - Entry into Sleep mode.

## 23.9 CAN registers

The peripheral registers have to be accessed by words (32-bit).

### 23.9.1 Register access protection

Erroneous access to certain configuration registers can cause the hardware to temporarily disturb the whole CAN network. Therefore the CAN\_BTR register can be modified by software only while the CAN hardware is in initialization mode.

Although the transmission of incorrect data will not cause problems at the CAN network level, it can severely disturb the application. A transmit mailbox can be only modified by software while it is in empty state, refer to [Figure 227: Transmit mailbox states](#).

The filter values can be modified either deactivating the associated filter banks or by setting the FINIT bit. Moreover, the modification of the filter configuration (scale, mode and FIFO assignment) in CAN\_FMR, CAN\_FSxR and CAN\_FFAR registers can only be done when the filter initialization mode is set (FINIT=1) in the CAN\_FMR register.

### 23.9.2 CAN control and status registers

Refer to [Section 1.1 on page 40](#) for a list of abbreviations used in register descriptions.

#### CAN master control register (CAN\_MCR)

Address offset: 0x00

Reset value: 0x0001 0002

	31	30	29	28	27	26	25	24	23	22	21	20	19	18	17	16
Reserved																DBF
																rw
	15	14	13	12	11	10	9	8	7	6	5	4	3	2	1	0
RESET	Reserved							TTCM	ABOM	AWUM	NART	RFLM	TXFP	SLEEP	INRQ	
rs								rw	rw	rw	rw	rw	rw	rw	rw	rw

Bits 31:17 Reserved, forced by hardware to 0.

Bit 16 **DBF**: Debug freeze

0: CAN working during debug

1: CAN reception/transmission frozen during debug. Reception FIFOs can still be accessed/controlled normally.

Bit 15 **RESET**: bxCAN software master reset  
0: Normal operation.  
1: Force a master reset of the bxCAN -> Sleep mode activated after reset (FMP bits and CAN\_MCR register are initialized to the reset values). This bit is automatically reset to 0.

Bits 14:8 Reserved, forced by hardware to 0.

Bit 7 **TTCM**: Time triggered communication mode  
0: Time Triggered Communication mode disabled.  
1: Time Triggered Communication mode enabled

*Note: For more information on Time Triggered Communication mode, please refer to [Section 23.7.2: Time triggered communication mode](#).*

Bit 6 **ABOM**: Automatic bus-off management  
This bit controls the behavior of the CAN hardware on leaving the Bus-Off state.  
0: The Bus-Off state is left on software request, once 128 occurrences of 11 recessive bits have been monitored and the software has first set and cleared the INRQ bit of the CAN\_MCR register.  
1: The Bus-Off state is left automatically by hardware once 128 occurrences of 11 recessive bits have been monitored.  
For detailed information on the Bus-Off state please refer to [Section 23.7.6: Error management](#).

Bit 5 **AWUM**: Automatic wakeup mode  
This bit controls the behavior of the CAN hardware on message reception during Sleep mode.  
0: The Sleep mode is left on software request by clearing the SLEEP bit of the CAN\_MCR register.  
1: The Sleep mode is left automatically by hardware on CAN message detection. The SLEEP bit of the CAN\_MCR register and the SLAK bit of the CAN\_MSR register are cleared by hardware.

Bit 4 **NART**: No automatic retransmission  
0: The CAN hardware will automatically retransmit the message until it has been successfully transmitted according to the CAN standard.  
1: A message will be transmitted only once, independently of the transmission result (successful, error or arbitration lost).

Bit 3 **RFLM**: Receive FIFO locked mode  
0: Receive FIFO not locked on overrun. Once a receive FIFO is full the next incoming message will overwrite the previous one.  
1: Receive FIFO locked against overrun. Once a receive FIFO is full the next incoming message will be discarded.

Bit 2 **TXFP**: Transmit FIFO priority  
This bit controls the transmission order when several mailboxes are pending at the same time.  
0: Priority driven by the identifier of the message  
1: Priority driven by the request order (chronologically)

Bit 1 **SLEEP**: Sleep mode request  
This bit is set by software to request the CAN hardware to enter the Sleep mode. Sleep mode will be entered as soon as the current CAN activity (transmission or reception of a CAN frame) has been completed.  
This bit is cleared by software to exit Sleep mode.  
This bit is cleared by hardware when the AWUM bit is set and a SOF bit is detected on the CAN Rx signal.  
This bit is set after reset - CAN starts in Sleep mode.

Bit 0 **INRQ**: Initialization request

The software clears this bit to switch the hardware into normal mode. Once 11 consecutive recessive bits have been monitored on the Rx signal the CAN hardware is synchronized and ready for transmission and reception. Hardware signals this event by clearing the INAK bit in the CAN\_MSR register.

Software sets this bit to request the CAN hardware to enter initialization mode. Once software has set the INRQ bit, the CAN hardware waits until the current CAN activity (transmission or reception) is completed before entering the initialization mode. Hardware signals this event by setting the INAK bit in the CAN\_MSR register.

**CAN master status register (CAN\_MSR)**

Address offset: 0x04

Reset value: 0x0000 0C02

31	30	29	28	27	26	25	24	23	22	21	20	19	18	17	16	
Reserved																
15	14	13	12	11	10	9	8	7	6	5	4	3	2	1	0	
Reserved.				RX	SAMP	RXM	TXM	Reserved				SLAKI	WKUI	ERRI	SLAK	INAK
				r	r	r	r					rc_w1	rc_w1	rc_w1	r	r

Bits 31:12 Reserved, forced by hardware to 0.

Bit 11 **RX**: CAN Rx signal

Monitors the actual value of the **CAN\_RX** Pin.

Bit 10 **SAMP**: Last sample point

The value of RX on the last sample point (current received bit value).

Bit 9 **RXM**: Receive mode

The CAN hardware is currently receiver.

Bit 8 **TXM**: Transmit mode

The CAN hardware is currently transmitter.

Bits 7:5 Reserved, forced by hardware to 0.

Bit 4 **SLAKI**: Sleep acknowledge interrupt

When SLKIE=1, this bit is set by hardware to signal that the bxCAN has entered Sleep Mode. When set, this bit generates a status change interrupt if the SLKIE bit in the CAN\_IER register is set.

This bit is cleared by software or by hardware, when SLAK is cleared.

*Note: When SLKIE=0, no polling on SLAKI is possible. In this case the SLAK bit can be polled.*

Bit 3 **WKUI**: Wakeup interrupt

This bit is set by hardware to signal that a SOF bit has been detected while the CAN hardware was in Sleep mode. Setting this bit generates a status change interrupt if the WKUIE bit in the CAN\_IER register is set.

This bit is cleared by software.



Bit 2 **ERRI**: Error interrupt

This bit is set by hardware when a bit of the CAN\_ESR has been set on error detection and the corresponding interrupt in the CAN\_IER is enabled. Setting this bit generates a status change interrupt if the ERRIE bit in the CAN\_IER register is set.  
This bit is cleared by software.

Bit 1 **SLAK**: Sleep acknowledge

This bit is set by hardware and indicates to the software that the CAN hardware is now in Sleep mode. This bit acknowledges the Sleep mode request from the software (set SLEEP bit in CAN\_MCR register).  
This bit is cleared by hardware when the CAN hardware has left Sleep mode (to be synchronized on the CAN bus). To be synchronized the hardware has to monitor a sequence of 11 consecutive recessive bits on the CAN RX signal.

*Note: The process of leaving Sleep mode is triggered when the SLEEP bit in the CAN\_MCR register is cleared. Please refer to the AWUM bit of the CAN\_MCR register description for detailed information for clearing SLEEP bit*

Bit 0 **INAK**: Initialization acknowledge

This bit is set by hardware and indicates to the software that the CAN hardware is now in initialization mode. This bit acknowledges the initialization request from the software (set INRQ bit in CAN\_MCR register).  
This bit is cleared by hardware when the CAN hardware has left the initialization mode (to be synchronized on the CAN bus). To be synchronized the hardware has to monitor a sequence of 11 consecutive recessive bits on the CAN RX signal.

**CAN transmit status register (CAN\_TSR)**

Address offset: 0x08

Reset value: 0x1C00 0000

31	30	29	28	27	26	25	24	23	22	21	20	19	18	17	16
LOW2	LOW1	LOW0	TME2	TME1	TME0	CODE[1:0]		ABRQ 2	Reserved			TERR 2	ALST2	TXOK 2	RQCP 2
r	r	r	r	r	r	r	r	rs				rc_w1	rc_w1	rc_w1	rc_w1
15	14	13	12	11	10	9	8	7	6	5	4	3	2	1	0
ABRQ 1	Reserved Res.			TERR 1	ALST1	TXOK 1	RQCP 1	ABRQ 0	Reserved			TERR 0	ALST0	TXOK 0	RQCP 0
rs				rc_w1	rc_w1	rc_w1	rc_w1	rs				rc_w1	rc_w1	rc_w1	rc_w1

Bit 31 **LOW2**: Lowest priority flag for mailbox 2

This bit is set by hardware when more than one mailbox are pending for transmission and mailbox 2 has the lowest priority.

Bit 30 **LOW1**: Lowest priority flag for mailbox 1

This bit is set by hardware when more than one mailbox are pending for transmission and mailbox 1 has the lowest priority.

Bit 29 **LOW0**: Lowest priority flag for mailbox 0

This bit is set by hardware when more than one mailbox are pending for transmission and mailbox 0 has the lowest priority.

*Note: The LOW[2:0] bits are set to zero when only one mailbox is pending.*

Bit 28 **TME2**: Transmit mailbox 2 empty

This bit is set by hardware when no transmit request is pending for mailbox 2.

- Bit 27 **TME1**: Transmit mailbox 1 empty  
This bit is set by hardware when no transmit request is pending for mailbox 1.
- Bit 26 **TME0**: Transmit mailbox 0 empty  
This bit is set by hardware when no transmit request is pending for mailbox 0.
- Bits 25:24 **CODE[1:0]**: Mailbox code  
In case at least one transmit mailbox is free, the code value is equal to the number of the next transmit mailbox free.  
In case all transmit mailboxes are pending, the code value is equal to the number of the transmit mailbox with the lowest priority.
- Bit 23 **ABRQ2**: Abort request for mailbox 2  
Set by software to abort the transmission request for the corresponding mailbox.  
Cleared by hardware when the mailbox becomes empty.  
Setting this bit has no effect when the mailbox is not pending for transmission.
- Bits 22:20 Reserved, forced by hardware to 0.
- Bit 19 **TERR2**: Transmission error of mailbox 2  
This bit is set when the previous TX failed due to an error.
- Bit 18 **ALST2**: Arbitration lost for mailbox 2  
This bit is set when the previous TX failed due to an arbitration lost.
- Bit 17 **TXOK2**: Transmission OK of mailbox 2  
The hardware updates this bit after each transmission attempt.  
0: The previous transmission failed  
1: The previous transmission was successful  
This bit is set by hardware when the transmission request on mailbox 2 has been completed successfully. Please refer to [Figure 227](#).
- Bit 16 **RQCP2**: Request completed mailbox2  
Set by hardware when the last request (transmit or abort) has been performed.  
Cleared by software writing a "1" or by hardware on transmission request (TXRQ2 set in CAN\_TMD2R register).  
Clearing this bit clears all the status bits (TXOK2, ALST2 and TERR2) for Mailbox 2.
- Bit 15 **ABRQ1**: Abort request for mailbox 1  
Set by software to abort the transmission request for the corresponding mailbox.  
Cleared by hardware when the mailbox becomes empty.  
Setting this bit has no effect when the mailbox is not pending for transmission.
- Bits 14:12 Reserved, forced by hardware to 0.
- Bit 11 **TERR1**: Transmission error of mailbox1  
This bit is set when the previous TX failed due to an error.
- Bit 10 **ALST1**: Arbitration lost for mailbox1  
This bit is set when the previous TX failed due to an arbitration lost.
- Bit 9 **TXOK1**: Transmission OK of mailbox1  
The hardware updates this bit after each transmission attempt.  
0: The previous transmission failed  
1: The previous transmission was successful  
This bit is set by hardware when the transmission request on mailbox 1 has been completed successfully. Please refer to [Figure 227](#)

- Bit 8 **RQCP1**: Request completed mailbox1  
 Set by hardware when the last request (transmit or abort) has been performed.  
 Cleared by software writing a “1” or by hardware on transmission request (TXRQ1 set in CAN\_T11R register).  
 Clearing this bit clears all the status bits (TXOK1, ALST1 and TERR1) for Mailbox 1.
- Bit 7 **ABRQ0**: Abort request for mailbox0  
 Set by software to abort the transmission request for the corresponding mailbox.  
 Cleared by hardware when the mailbox becomes empty.  
 Setting this bit has no effect when the mailbox is not pending for transmission.
- Bits 6:4 Reserved, forced by hardware to 0.
- Bit 3 **TERR0**: Transmission error of mailbox0  
 This bit is set when the previous TX failed due to an error.
- Bit 2 **ALST0**: Arbitration lost for mailbox0  
 This bit is set when the previous TX failed due to an arbitration lost.
- Bit 1 **TXOK0**: Transmission OK of mailbox0  
 The hardware updates this bit after each transmission attempt.  
 0: The previous transmission failed  
 1: The previous transmission was successful  
 This bit is set by hardware when the transmission request on mailbox 1 has been completed successfully. Please refer to [Figure 227](#)
- Bit 0 **RQCP0**: Request completed mailbox0  
 Set by hardware when the last request (transmit or abort) has been performed.  
 Cleared by software writing a “1” or by hardware on transmission request (TXRQ0 set in CAN\_T10R register).  
 Clearing this bit clears all the status bits (TXOK0, ALST0 and TERR0) for Mailbox 0.

**CAN receive FIFO 0 register (CAN\_RF0R)**

Address offset: 0x0C  
 Reset value: 0x00

31	30	29	28	27	26	25	24	23	22	21	20	19	18	17	16
Reserved															
15	14	13	12	11	10	9	8	7	6	5	4	3	2	1	0
Reserved										RFOM0	FOVR0	FULL0	Res.	FMP0[1:0]	
										rs	rc_w1	rc_w1	Res.	r	r

- Bit 31:6 Reserved, forced by hardware to 0.
- Bit 5 **RFOM0**: Release FIFO 0 output mailbox  
 Set by software to release the output mailbox of the FIFO. The output mailbox can only be released when at least one message is pending in the FIFO. Setting this bit when the FIFO is empty has no effect. If at least two messages are pending in the FIFO, the software has to release the output mailbox to access the next message.  
 Cleared by hardware when the output mailbox has been released.

Bit 4 **FOVR0**: FIFO 0 overrun

This bit is set by hardware when a new message has been received and passed the filter while the FIFO was full.

This bit is cleared by software.

Bit 3 **FULL0**: FIFO 0 full

Set by hardware when three messages are stored in the FIFO.

This bit is cleared by software.

Bit 2 Reserved, forced by hardware to 0.

Bits 1:0 **FMP0[1:0]**: FIFO 0 message pending

These bits indicate how many messages are pending in the receive FIFO.

FMP is increased each time the hardware stores a new message in to the FIFO. FMP is decreased each time the software releases the output mailbox by setting the RFOM0 bit.

### CAN receive FIFO 1 register (CAN\_RF1R)

Address offset: 0x10

Reset value: 0x00

31	30	29	28	27	26	25	24	23	22	21	20	19	18	17	16
Reserved															
15	14	13	12	11	10	9	8	7	6	5	4	3	2	1	0
Reserved										RFOM1	FOVR1	FULL1	Res.	FMP1[1:0]	
										rs	rc_w1	rc_w1		r	r

Bits 31:6 Reserved, forced by hardware to 0.

Bit 5 **RFOM1**: Release FIFO 1 output mailbox

Set by software to release the output mailbox of the FIFO. The output mailbox can only be released when at least one message is pending in the FIFO. Setting this bit when the FIFO is empty has no effect. If at least two messages are pending in the FIFO, the software has to release the output mailbox to access the next message.

Cleared by hardware when the output mailbox has been released.

Bit 4 **FOVR1**: FIFO 1 overrun

This bit is set by hardware when a new message has been received and passed the filter while the FIFO was full.

This bit is cleared by software.

Bit 3 **FULL1**: FIFO 1 full

Set by hardware when three messages are stored in the FIFO.

This bit is cleared by software.

Bit 2 Reserved, forced by hardware to 0.

Bits 1:0 **FMP1[1:0]**: FIFO 1 message pending

These bits indicate how many messages are pending in the receive FIFO1.

FMP1 is increased each time the hardware stores a new message in to the FIFO1. FMP is decreased each time the software releases the output mailbox by setting the RFOM1 bit.

**CAN interrupt enable register (CAN\_IER)**

Address offset: 0x14

Reset value: 0x00

31	30	29	28	27	26	25	24	23	22	21	20	19	18	17	16
Reserved													SLKIE	WKUIE	
													rw	rw	
15	14	13	12	11	10	9	8	7	6	5	4	3	2	1	0
ERRIE	Reserved			LEC IE	BOF IE	EPV IE	EWG IE	Res.	FOV IE1	FF IE1	FMP IE1	FOV IE0	FF IE0	FMP IE0	TME IE
rw				rw	rw	rw	rw		rw	rw	rw	rw	rw	rw	rw

Bits 31:18 Reserved, forced by hardware to 0.

Bit 17 **SLKIE**: Sleep interrupt enable  
 0: No interrupt when SLAKI bit is set.  
 1: Interrupt generated when SLAKI bit is set.

Bit 16 **WKUIE**: Wakeup interrupt enable  
 0: No interrupt when WKUI is set.  
 1: Interrupt generated when WKUI bit is set.

Bit 15 **ERRIE**: Error interrupt enable  
 0: No interrupt will be generated when an error condition is pending in the CAN\_ESR.  
 1: An interrupt will be generation when an error condition is pending in the CAN\_ESR.

Bits 14:12 Reserved, forced by hardware to 0.

Bit 11 **LECIIE**: Last error code interrupt enable  
 0: ERRI bit will not be set when the error code in LEC[2:0] is set by hardware on error detection.  
 1: ERRI bit will be set when the error code in LEC[2:0] is set by hardware on error detection.

Bit 10 **BOFIE**: Bus-off interrupt enable  
 0: ERRI bit will not be set when BOFF is set.  
 1: ERRI bit will be set when BOFF is set.

Bit 9 **EPVIE**: Error passive interrupt enable  
 0: ERRI bit will not be set when EPVF is set.  
 1: ERRI bit will be set when EPVF is set.

Bit 8 **EWGIE**: Error warning interrupt enable  
 0: ERRI bit will not be set when EWGF is set.  
 1: ERRI bit will be set when EWGF is set.

Bit 7 Reserved, forced by hardware to 0.

Bit 6 **FOVIE1**: FIFO overrun interrupt enable  
 0: No interrupt when FOVR is set.  
 1: Interrupt generation when FOVR is set.

Bit 5 **FFIE1**: FIFO full interrupt enable  
 0: No interrupt when FULL bit is set.  
 1: Interrupt generated when FULL bit is set.

- Bit 4 **FMPIE1**: FIFO message pending interrupt enable
    - 0: No interrupt generated when state of FMP[1:0] bits are not 00b.
    - 1: Interrupt generated when state of FMP[1:0] bits are not 00b.
  - Bit 3 **FOVIE0**: FIFO overrun interrupt enable
    - 0: No interrupt when FOVR bit is set.
    - 1: Interrupt generated when FOVR bit is set.
  - Bit 2 **FFIE0**: FIFO full interrupt enable
    - 0: No interrupt when FULL bit is set.
    - 1: Interrupt generated when FULL bit is set.
  - Bit 1 **FMPIE0**: FIFO message pending interrupt enable
    - 0: No interrupt generated when state of FMP[1:0] bits are not 00b.
    - 1: Interrupt generated when state of FMP[1:0] bits are not 00b.
  - Bit 0 **TMEIE**: Transmit mailbox empty interrupt enable
    - 0: No interrupt when RQCPx bit is set.
    - 1: Interrupt generated when RQCPx bit is set.
- Note: Refer to [Section 23.8: bxCAN interrupts](#).*

**CAN error status register (CAN\_ESR)**

Address offset: 0x18  
 Reset value: 0x00

31	30	29	28	27	26	25	24	23	22	21	20	19	18	17	16
REC[7:0]								TEC[7:0]							
r	r	r	r	r	r	r	r	r	r	r	r	r	r	r	r
15	14	13	12	11	10	9	8	7	6	5	4	3	2	1	0
Reserved									LEC[2:0]			Res.	BOFF	EPVF	EWGF
									nw	nw	nw		r	r	r

- Bits 31:24 **REC[7:0]**: Receive error counter
 

The implementing part of the fault confinement mechanism of the CAN protocol. In case of an error during reception, this counter is incremented by 1 or by 8 depending on the error condition as defined by the CAN standard. After every successful reception the counter is decremented by 1 or reset to 120 if its value was higher than 128. When the counter value exceeds 127, the CAN controller enters the error passive state.
- Bits 23:16 **TEC[7:0]**: Least significant byte of the 9-bit transmit error counter
 

The implementing part of the fault confinement mechanism of the CAN protocol.
- Bits 15:7 Reserved, forced by hardware to 0.

Bits 6:4 **LEC[2:0]**: Last error code

This field is set by hardware and holds a code which indicates the error condition of the last error detected on the CAN bus. If a message has been transferred (reception or transmission) without error, this field will be cleared to '0'.

Code 7 is unused and may be written by the hardware to check for an update

- 000: No Error
- 001: Stuff Error
- 010: Form Error
- 011: Acknowledgment Error
- 100: Bit recessive Error
- 101: Bit dominant Error
- 110: CRC Error
- 111: Set by software

Bit 3 Reserved, forced by hardware to 0.

Bit 2 **BOFF**: Bus-off flag

This bit is set by hardware when it enters the bus-off state. The bus-off state is entered on TEC overflow, greater than 255, refer to [Section 23.7.6 on page 626](#).

Bit 1 **EPVF**: Error passive flag

This bit is set by hardware when the Error Passive limit has been reached (Receive Error Counter or Transmit Error Counter > 127).

Bit 0 **EWGF**: Error warning flag

This bit is set by hardware when the warning limit has been reached (Receive Error Counter or Transmit Error Counter ≥ 96).

### CAN bit timing register (CAN\_BTR)

Address offset: 0x1C

Reset value: 0x0123 0000

*Note: This register can only be accessed by the software when the CAN hardware is in initialization mode.*

31	30	29	28	27	26	25	24	23	22	21	20	19	18	17	16	
SILM	LBKM	Reserved				SJW[1:0]		Res.	TS2[2:0]			TS1[3:0]				
rw	rw					rw	rw		rw	rw	rw	rw	rw	rw	rw	rw
15	14	13	12	11	10	9	8	7	6	5	4	3	2	1	0	
Reserved						BRP[9:0]										
						rw	rw	rw	rw	rw	rw	rw	rw	rw	rw	rw

Bit 31 **SILM**: Silent mode (debug)

- 0: Normal operation
- 1: Silent Mode

Bit 30 **LBKM**: Loop back mode (debug)

- 0: Loop Back Mode disabled
- 1: Loop Back Mode enabled

Bits 29:26 Reserved, forced by hardware to 0.

- Bits 25:24 **SJW[1:0]**: Resynchronization jump width  
 These bits define the maximum number of time quanta the CAN hardware is allowed to lengthen or shorten a bit to perform the resynchronization.  
 $t_{RJW} = t_{CAN} \times (SJW[1:0] + 1)$
- Bit 23 Reserved, forced by hardware to 0.
- Bits 22:20 **TS2[2:0]**: Time segment 2  
 These bits define the number of time quanta in Time Segment 2.  
 $t_{BS2} = t_{CAN} \times (TS2[2:0] + 1)$
- Bits 19:16 **TS1[3:0]**: Time segment 1  
 These bits define the number of time quanta in Time Segment 1  
 $t_{BS1} = t_{CAN} \times (TS1[3:0] + 1)$   
 For more information on bit timing, please refer to [Section 23.7.7: Bit timing on page 626](#).
- Bits 15:10 Reserved, forced by hardware to 0.
- Bits 9:0 **BRP[9:0]**: Baud rate prescaler  
 These bits define the length of a time quanta.  
 $t_q = (BRP[9:0]+1) \times t_{PCLK}$

### 23.9.3 CAN mailbox registers

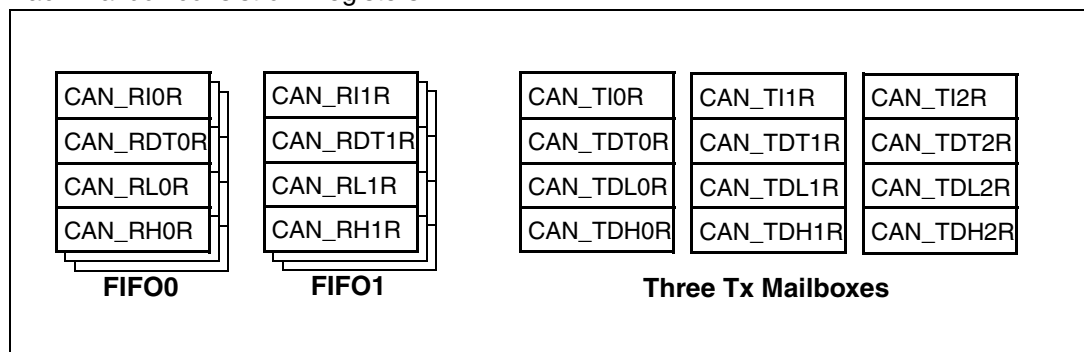
This chapter describes the registers of the transmit and receive mailboxes. Refer to [Section 23.7.5: Message storage on page 624](#) for detailed register mapping.

Transmit and receive mailboxes have the same registers except:

- The FMI field in the CAN\_RDTxR register.
- A receive mailbox is always write protected.
- A transmit mailbox is write-enabled only while empty, corresponding TME bit in the CAN\_TSR register set.

There are 3 TX Mailboxes and 2 RX Mailboxes. Each RX Mailbox allows access to a 3 level depth FIFO, the access being offered only to the oldest received message in the FIFO.

Each mailbox consist of 4 registers.





**CAN TX mailbox identifier register (CAN\_TlXR) (x=0..2)**

Address offsets: 0x180, 0x190, 0x1A0  
 Reset value: undefined (except bit 0, TXRQ = 0)

- Note:* 1 All TX registers are write protected when the mailbox is pending transmission (TMEx reset).  
 2 This register also implements the TX request control (bit 0) - reset value 0.

31	30	29	28	27	26	25	24	23	22	21	20	19	18	17	16
STID[10:0]/EXID[28:18]											EXID[17:13]				
rw	rw	rw	rw	rw	rw	rw	rw	rw	rw	rw	rw	rw	rw	rw	rw
15	14	13	12	11	10	9	8	7	6	5	4	3	2	1	0
EXID[12:0]												IDE	RTR	TXRQ	
rw	rw	rw	rw	rw	rw	rw	rw	rw	rw	rw	rw	rw	rw	rw	rw

- Bits 31:21 **STID[10:0]/EXID[28:18]**: Standard identifier or extended identifier  
 The standard identifier or the MSBs of the extended identifier (depending on the IDE bit value).
- Bit 20:3 **EXID[17:0]**: Extended identifier  
 The LSBs of the extended identifier.
- Bit 2 **IDE**: Identifier extension  
 This bit defines the identifier type of message in the mailbox.  
 0: Standard identifier.  
 1: Extended identifier.
- Bit 1 **RTR**: Remote transmission request  
 0: Data frame  
 1: Remote frame
- Bit 0 **TXRQ**: Transmit mailbox request  
 Set by software to request the transmission for the corresponding mailbox.  
 Cleared by hardware when the mailbox becomes empty.

**CAN mailbox data length control and time stamp register (CAN\_TDTxR)  
(x=0..2)**

All bits of this register are write protected when the mailbox is not in empty state.

Address offsets: 0x184, 0x194, 0x1A4

Reset value: undefined

31	30	29	28	27	26	25	24	23	22	21	20	19	18	17	16	
TIME[15:0]																
rw	rw	rw	rw	rw	rw	rw	rw	rw	rw	rw	rw	rw	rw	rw	rw	
15	14	13	12	11	10	9	8	7	6	5	4	3	2	1	0	
Reserved							TGT	Reserved					DLC[3:0]			
							rw						rw	rw	rw	rw

Bits 31:16 **TIME[15:0]**: Message time stamp

This field contains the 16-bit timer value captured at the SOF transmission.

Bits 15:9 Reserved

Bit 8 **TGT**: Transmit global time

This bit is active only when the hardware is in the Time Trigger Communication mode, TTCM bit of the CAN\_MCR register is set.

0: Time stamp TIME[15:0] is not sent.

1: Time stamp TIME[15:0] value is sent in the last two data bytes of the 8-byte message:

TIME[7:0] in data byte 7 and TIME[15:8] in data byte 6, replacing the data written in

CAN\_TDHxR[31:16] register (DATA6[7:0] and DATA7[7:0]). DLC must be programmed as 8 in order these two bytes to be sent over the CAN bus.

Bits 7:4 Reserved

Bits 3:0 **DLC[3:0]**: Data length code

This field defines the number of data bytes a data frame contains or a remote frame request.

A message can contain from 0 to 8 data bytes, depending on the value in the DLC field.

### CAN mailbox data low register (CAN\_TDLxR) (x=0..2)

All bits of this register are write protected when the mailbox is not in empty state.

Address offsets: 0x188, 0x198, 0x1A8

Reset value: undefined

31	30	29	28	27	26	25	24	23	22	21	20	19	18	17	16
DATA3[7:0]								DATA2[7:0]							
rw	rw	rw	rw	rw	rw	rw	rw	rw	rw	rw	rw	rw	rw	rw	rw
15	14	13	12	11	10	9	8	7	6	5	4	3	2	1	0
DATA1[7:0]								DATA0[7:0]							
rw	rw	rw	rw	rw	rw	rw	rw	rw	rw	rw	rw	rw	rw	rw	rw

Bits 31:24 **DATA3[7:0]**: Data byte 3

Data byte 3 of the message.

Bits 23:16 **DATA2[7:0]**: Data byte 2

Data byte 2 of the message.

Bits 15:8 **DATA1[7:0]**: Data byte 1

Data byte 1 of the message.

Bits 7:0 **DATA0[7:0]**: Data byte 0

Data byte 0 of the message.

A message can contain from 0 to 8 data bytes and starts with byte 0.

### CAN mailbox data high register (CAN\_TDHxR) (x=0..2)

All bits of this register are write protected when the mailbox is not in empty state.

Address offsets: 0x18C, 0x19C, 0x1AC

Reset value: undefined

31	30	29	28	27	26	25	24	23	22	21	20	19	18	17	16
DATA7[7:0]								DATA6[7:0]							
rw	rw	rw	rw	rw	rw	rw	rw	rw	rw	rw	rw	rw	rw	rw	rw
15	14	13	12	11	10	9	8	7	6	5	4	3	2	1	0
DATA5[7:0]								DATA4[7:0]							
rw	rw	rw	rw	rw	rw	rw	rw	rw	rw	rw	rw	rw	rw	rw	rw

Bits 31:24 **DATA7[7:0]**: Data byte 7

Data byte 7 of the message.

*Note: If TGT of this message and TTCM are active, DATA7 and DATA6 will be replaced by the TIME stamp value.*

Bits 23:16 **DATA6[7:0]**: Data byte 6

Data byte 6 of the message.

Bits 15:8 **DATA5[7:0]**: Data byte 5

Data byte 5 of the message.

Bits 7:0 **DATA4[7:0]**: Data byte 4

Data byte 4 of the message.

**CAN receive FIFO mailbox identifier register (CAN\_RlXR) (x=0..1)**

Address offsets: 0x1B0, 0x1C0

Reset value: undefined

*Note: All RX registers are write protected.*

31	30	29	28	27	26	25	24	23	22	21	20	19	18	17	16
STID[10:0]/EXID[28:18]											EXID[17:13]				
r	r	r	r	r	r	r	r	r	r	r	r	r	r	r	r
15	14	13	12	11	10	9	8	7	6	5	4	3	2	1	0
EXID[12:0]													IDE	RTR	Res.
r	r	r	r	r	r	r	r	r	r	r	r	r	r	r	

Bits 31:21 **STID[10:0]/EXID[28:18]**: Standard identifier or extended identifier  
 The standard identifier or the MSBs of the extended identifier (depending on the IDE bit value).

Bits 20:3 **EXID[17:0]**: Extended identifier  
 The LSBs of the extended identifier.

Bit 2 **IDE**: Identifier extension  
 This bit defines the identifier type of message in the mailbox.  
 0: Standard identifier.  
 1: Extended identifier.

Bit 1 **RTR**: Remote transmission request  
 0: Data frame  
 1: Remote frame

Bit 0 Reserved

**CAN receive FIFO mailbox data length control and time stamp register (CAN\_RDTxR) (x=0..1)**

Address offsets: 0x1B4, 0x1C4  
 Reset value: undefined

*Note: All RX registers are write protected.*

31	30	29	28	27	26	25	24	23	22	21	20	19	18	17	16
TIME[15:0]															
r	r	r	r	r	r	r	r	r	r	r	r	r	r	r	r
15	14	13	12	11	10	9	8	7	6	5	4	3	2	1	0
FMI[7:0]								Reserved				DLC[3:0]			
r	r	r	r	r	r	r	r					r	r	r	r

- Bits 31:16 **TIME[15:0]**: Message time stamp  
 This field contains the 16-bit timer value captured at the SOF detection.
- Bits 15:8 **FMI[7:0]**: Filter match index  
 This register contains the index of the filter the message stored in the mailbox passed through. For more details on identifier filtering please refer to [Section 23.7.4: Identifier filtering on page 620](#) - **Filter Match Index** paragraph.
- Bits 7:4 Reserved, forced by hardware to 0.
- Bits 3:0 **DLC[3:0]**: Data length code  
 This field defines the number of data bytes a data frame contains (0 to 8). It is 0 in the case of a remote frame request.

**CAN receive FIFO mailbox data low register (CAN\_RDLxR) (x=0..1)**

All bits of this register are write protected when the mailbox is not in empty state.

Address offsets: 0x1B8, 0x1C8

Reset value: undefined

*Note: All RX registers are write protected.*

31	30	29	28	27	26	25	24	23	22	21	20	19	18	17	16
DATA3[7:0]								DATA2[7:0]							
r	r	r	r	r	r	r	r	r	r	r	r	r	r	r	r
15	14	13	12	11	10	9	8	7	6	5	4	3	2	1	0
DATA1[7:0]								DATA0[7:0]							
r	r	r	r	r	r	r	r	r	r	r	r	r	r	r	r

Bits 31:24 **DATA3[7:0]**: Data Byte 3

Data byte 3 of the message.

Bits 23:16 **DATA2[7:0]**: Data Byte 2

Data byte 2 of the message.

Bits 15:8 **DATA1[7:0]**: Data Byte 1

Data byte 1 of the message.

Bits 7:0 **DATA0[7:0]**: Data Byte 0

Data byte 0 of the message.

A message can contain from 0 to 8 data bytes and starts with byte 0.

**CAN receive FIFO mailbox data high register (CAN\_RDHxR) (x=0..1)**

Address offsets: 0x1BC, 0x1CC

Reset value: undefined

*Note: All RX registers are write protected.*

31	30	29	28	27	26	25	24	23	22	21	20	19	18	17	16
DATA7[7:0]								DATA6[7:0]							
r	r	r	r	r	r	r	r	r	r	r	r	r	r	r	r
15	14	13	12	11	10	9	8	7	6	5	4	3	2	1	0
DATA5[7:0]								DATA4[7:0]							
r	r	r	r	r	r	r	r	r	r	r	r	r	r	r	r

Bits 31:24 **DATA7[7:0]**: Data Byte 7

Data byte 3 of the message.

Bits 23:16 **DATA6[7:0]**: Data Byte 6

Data byte 2 of the message.

Bits 15:8 **DATA5[7:0]**: Data Byte 5  
Data byte 1 of the message.

Bits 7:0 **DATA4[7:0]**: Data Byte 4  
Data byte 0 of the message.

### 23.9.4 CAN filter registers

#### CAN filter master register (CAN\_FMR)

Address offset: 0x200  
Reset value: 0x2A1C 0E01

*Note:* All bits of this register are set and cleared by software.

31	30	29	28	27	26	25	24	23	22	21	20	19	18	17	16
Reserved															
15	14	13	12	11	10	9	8	7	6	5	4	3	2	1	0
Reserved															FINIT
															rw
Reserved		CAN2SB[5:0]					Reserved				FINIT				
		rw	rw	rw	rw	rw	rw					rw			

Bits 31:14 Reserved, forced to reset value

Bits 13:8 **CAN2SB[5:0]**: CAN2 start bank  
These bits are set and cleared by software. They define the start bank for the CAN2 interface (Slave) in the range 1 to 27.  
*Note:* These bits are available in connectivity line devices only and are reserved otherwise.

Bits 7:1 Reserved, forced to reset value

Bit 0 **FINIT**: Filter init mode  
Initialization mode for filter banks  
0: Active filters mode.  
1: Initialization mode for the filters.

**CAN filter mode register (CAN\_FM1R)**

Address offset: 0x204

Reset value: 0x00

*Note: This register can be written only when the filter initialization mode is set (FINIT=1) in the CAN\_FMR register.*

31	30	29	28	27	26	25	24	23	22	21	20	19	18	17	16
Reserved				FBM27	FBM26	FBM25	FBM24	FBM23	FBM22	FBM21	FBM20	FBM19	FBM18	FBM17	FBM16
				rw	rw	rw	rw	rw	rw	rw	rw	rw	rw	rw	rw
15	14	13	12	11	10	9	8	7	6	5	4	3	2	1	0
FBM15	FBM14	FBM13	FBM12	FBM11	FBM10	FBM9	FBM8	FBM7	FBM6	FBM5	FBM4	FBM3	FBM2	FBM1	FBM0
rw	rw	rw	rw	rw	rw	rw	rw	rw	rw	rw	rw	rw	rw	rw	rw

*Note: Please refer to [Figure 229: Filter bank scale configuration - register organization on page 622](#)*

Bits 31:28 Reserved. Forced to 0 by hardware.

Bits 27:0 **FBMx**: Filter mode

Mode of the registers of Filter x.

0: Two 32-bit registers of filter bank x are in Identifier Mask mode.

1: Two 32-bit registers of filter bank x are in Identifier List mode.

*Note: Bits 27:14 are available in connectivity line devices only and are reserved otherwise.*

**CAN filter scale register (CAN\_FS1R)**

Address offset: 0x20C

Reset value: 0x00

*Note: This register can be written only when the filter initialization mode is set (FINIT=1) in the CAN\_FMR register.*

31	30	29	28	27	26	25	24	23	22	21	20	19	18	17	16
Reserved				FSC27	FSC26	FSC25	FSC24	FSC23	FSC22	FSC21	FSC20	FSC19	FSC18	FSC17	FSC16
				rw	rw	rw	rw	rw	rw	rw	rw	rw	rw	rw	rw
15	14	13	12	11	10	9	8	7	6	5	4	3	2	1	0
FSC15	FSC14	FSC13	FSC12	FSC11	FSC10	FSC9	FSC8	FSC7	FSC6	FSC5	FSC4	FSC3	FSC2	FSC1	FSC0
rw	rw	rw	rw	rw	rw	rw	rw	rw	rw	rw	rw	rw	rw	rw	rw

*Note: Please refer to [Figure 229: Filter bank scale configuration - register organization on page 622](#)*

Bits 31:28 Reserved, forced by hardware to 0.

Bits 27:0 **FSCx**: Filter scale configuration

These bits define the scale configuration of Filters 13-0.

0: Dual 16-bit scale configuration

1: Single 32-bit scale configuration

*Note: Bits 27:14 are available in connectivity line devices only and are reserved otherwise.*



**CAN filter FIFO assignment register (CAN\_FFA1R)**

Address offset: 0x214

Reset value: 0x00

*Note: This register can be written only when the filter initialization mode is set (FINIT=1) in the CAN\_FMR register.*

31	30	29	28	27	26	25	24	23	22	21	20	19	18	17	16
Reserved				FFA27	FFA26	FFA25	FFA24	FFA23	FFA22	FFA21	FFA20	FFA19	FFA18	FFA17	FFA16
				rw	rw	rw	rw	rw	rw	rw	rw	rw	rw	rw	rw
15	14	13	12	11	10	9	8	7	6	5	4	3	2	1	0
FFA15	FFA14	FFA13	FFA12	FFA11	FFA10	FFA9	FFA8	FFA7	FFA6	FFA5	FFA4	FFA3	FFA2	FFA1	FFA0
rw	rw	rw	rw	rw	rw	rw	rw	rw	rw	rw	rw	rw	rw	rw	rw

Bits 31:28 Reserved, forced by hardware to 0.

Bits 27:0 **FFAx**: Filter FIFO assignment for filter x

The message passing through this filter will be stored in the specified FIFO.

0: Filter assigned to FIFO 0

1: Filter assigned to FIFO 1

*Note: Bits 27:14 are available in connectivity line devices only and are reserved otherwise.*

**CAN filter activation register (CAN\_FA1R)**

Address offset: 0x21C

Reset value: 0x00

31	30	29	28	27	26	25	24	23	22	21	20	19	18	17	16
Reserved				FACT27	FACT26	FACT25	FACT24	FACT23	FACT22	FACT21	FACT20	FACT19	FACT18	FACT17	FACT16
				rw	rw	rw	rw	rw	rw	rw	rw	rw	rw	rw	rw
15	14	13	12	11	10	9	8	7	6	5	4	3	2	1	0
FACT15	FACT14	FACT13	FACT12	FACT11	FACT10	FACT9	FACT8	FACT7	FACT6	FACT5	FACT4	FACT3	FACT2	FACT1	FACT0
rw	rw	rw	rw	rw	rw	rw	rw	rw	rw	rw	rw	rw	rw	rw	rw

Bits 31:28 Reserved, forced by hardware to 0.

Bits 27:0 **FACTx**: Filter active

The software sets this bit to activate Filter x. To modify the Filter x registers (CAN\_FxR[0:7]), the FACTx bit must be cleared or the FINIT bit of the CAN\_FMR register must be set.

0: Filter x is not active

1: Filter x is active

*Note: Bits 27:14 are available in connectivity line devices only and are reserved otherwise.*

**Filter bank i register x (CAN\_FiRx) (i=0..27 in connectivity line devices,, x=1, 2)**

Address offsets: 0x240..0x31C  
 Reset value: undefined

*Note:* In connectivity line devices there are 28 filter banks, i=0 .. 27, in other devices there are 14 filter banks i = 0 ..13. Each filter bank i is composed of two 32-bit registers, CAN\_FiR[2:1].  
 This register can only be modified when the FACTx bit of the CAN\_FAxR register is cleared or when the FINIT bit of the CAN\_FMR register is set.

31	30	29	28	27	26	25	24	23	22	21	20	19	18	17	16
FB31	FB30	FB29	FB28	FB27	FB26	FB25	FB24	FB23	FB22	FB21	FB20	FB19	FB18	FB17	FB16
rw	rw	rw	rw	rw	rw	rw	rw	rw	rw	rw	rw	rw	rw	rw	rw
15	14	13	12	11	10	9	8	7	6	5	4	3	2	1	0
FB15	FB14	FB13	FB12	FB11	FB10	FB9	FB8	FB7	FB6	FB5	FB4	FB3	FB2	FB1	FB0
rw	rw	rw	rw	rw	rw	rw	rw	rw	rw	rw	rw	rw	rw	rw	rw

In all configurations:

Bits 31:0 **FB[31:0]**: Filter bits

**Identifier**

Each bit of the register specifies the level of the corresponding bit of the expected identifier.  
 0: Dominant bit is expected  
 1: Recessive bit is expected

**Mask**

Each bit of the register specifies whether the bit of the associated identifier register must match with the corresponding bit of the expected identifier or not.  
 0: Don't care, the bit is not used for the comparison  
 1: Must match, the bit of the incoming identifier must have the same level has specified in the corresponding identifier register of the filter.

*Note:* Depending on the scale and mode configuration of the filter the function of each register can differ. For the filter mapping, functions description and mask registers association, refer to [Section 23.7.4: Identifier filtering on page 620](#).

A Mask/Identifier register in **mask mode** has the same bit mapping as in **identifier list** mode.

For the register mapping/addresses of the filter banks please refer to the [Table 178 on page 651](#).

### 23.9.5 bxCAN register map

Refer to [Table 1 on page 44](#) for the register boundary addresses. In connectivity line devices, the registers from offset 0x200 to 31C are present only in CAN1.

**Table 178. bxCAN register map and reset values**

Offset	Register	31	30	29	28	27	26	25	24	23	22	21	20	19	18	17	16	15	14	13	12	11	10	9	8	7	6	5	4	3	2	1	0			
0x000	CAN_MCR	Reserved															DBF	RESET	Reserved										TTCM	ABOM	AWUM	NART	RFLM	TXFP	SLEEP	INRQ
	Reset value																1	0											0	0	0	0	0	0	0	1
0x004	CAN_MSR	Reserved										Reserved				RX	SAMP	RXM	TXM	Reserved										SLAKI	WKUI	ERRI	SLAK	INAK		
	Reset value															1	1	0	0											0	0	0	1	0		
0x008	CAN_TSR	LOW[2:0]		TME[2:0]		CODE[1:0]		ABRQ2		Reserved				TERR2	ALST2	TXOK2	RQCP2	ABRQ1	Reserved				TERR1	ALST1	TXOK1	RQCP1	ABRQ0	Reserved				TERR0	ALST0	TXOK0	RQCP0	
	Reset value	0	0	0	1	1	1	0	0	0					0	0	0	0	0					0	0	0	0	0					0	0	0	0
0x00C	CAN_RF0R	Reserved																										RFOM0	FOVR0	FULL0	Reserved		FMP0[1:0]			
	Reset value																											0	0	0	Reserved		0	0		
0x010	CAN_RF1R	Reserved																										RFOM1	FOVR1	FULL1	Reserved		FMP1[1:0]			
	Reset value																											0	0	0	Reserved		0	0		
0x014	CAN_IER	Reserved														SLKIE	WKUIE	ERRIE	Reserved				LECIE	BOFIE	EPVIE	EWGIE	Reserved		FOVIE1	FFIE1	FMPIE1	FOVIE0	FFIE0	FMPIE0	TMEIE	
	Reset value															0	0	0					0	0	0	0	Reserved		0	0	0	0	0	0	0	
0x018	CAN_ESR	REC[7:0]						TEC[7:0]						Reserved										LEC[2:0]		Reserved		BOFF	EPVF	EWGF						
	Reset value	0	0	0	0	0	0	0	0	0	0	0	0	0	0	0	0											0	0	0	Reserved		0	0	0	
0x01C	CAN_BTR	SILM	LBKM	Reserved				SJW[1:0]		Reserved		TS2[2:0]		TS1[3:0]			Reserved						BRP[9:0]													
	Reset value	0	0					0	0	Reserved		0		1									0													
0x020-0x17F	Reserved																																			
0x180	CAN_TI0R	STID[10:0]/EXID[28:18]														EXID[17:0]														IDE	RTR	TXRQ				
	Reset value	x	x	x	x	x	x	x	x	x	x	x	x	x	x	x	x	x	x	x	x	x	x	x	x	x	x	x	x	x	x	x	0			
0x184	CAN_TDT0R	TIME[15:0]															Reserved						TGT	Reserved				DLC[3:0]								
	Reset value	x	x	x	x	x	x	x	x	x	x	x	x	x	x	x	x	x	x	x	x	x	x	x	x	x	x	x	x	x	x	x	x			
0x188	CAN_TDL0R	DATA3[7:0]						DATA2[7:0]						DATA1[7:0]						DATA0[7:0]																
	Reset value	x	x	x	x	x	x	x	x	x	x	x	x	x	x	x	x	x	x	x	x	x	x	x	x	x	x	x	x	x	x	x	x			
0x18C	CAN_TDH0R	DATA7[7:0]						DATA6[7:0]						DATA5[7:0]						DATA4[7:0]																
	Reset value	x	x	x	x	x	x	x	x	x	x	x	x	x	x	x	x	x	x	x	x	x	x	x	x	x	x	x	x	x	x	x	x			
0x190	CAN_TI1R	STID[10:0]/EXID[28:18]														EXID[17:0]														IDE	RTR	TXRQ				
	Reset value	x	x	x	x	x	x	x	x	x	x	x	x	x	x	x	x	x	x	x	x	x	x	x	x	x	x	x	x	x	x	x	0			

Table 178. bxCAN register map and reset values (continued)

Offset	Register	31	30	29	28	27	26	25	24	23	22	21	20	19	18	17	16	15	14	13	12	11	10	9	8	7	6	5	4	3	2	1	0	
0x194	CAN_TDT1R	TIME[15:0]														Reserved				TGT	Reserved			DLC[3:0]										
	Reset value	x	x	x	x	x	x	x	x	x	x	x	x	x	x	x	x	x	x	x	x	x	x	x	x	x	x	x	x	x	x	x	x	
0x198	CAN_TDL1R	DATA3[7:0]							DATA2[7:0]							DATA1[7:0]							DATA0[7:0]											
	Reset value	x	x	x	x	x	x	x	x	x	x	x	x	x	x	x	x	x	x	x	x	x	x	x	x	x	x	x	x	x	x	x	x	
0x19C	CAN_TDH1R	DATA7[7:0]							DATA6[7:0]							DATA5[7:0]							DATA4[7:0]											
	Reset value	x	x	x	x	x	x	x	x	x	x	x	x	x	x	x	x	x	x	x	x	x	x	x	x	x	x	x	x	x	x	x	x	
0x1A0	CAN_TI2R	STID[10:0]/EXID[28:18]														EXID[17:0]											IDE	RTR	TXRQ					
	Reset value	x	x	x	x	x	x	x	x	x	x	x	x	x	x	x	x	x	x	x	x	x	x	x	x	x	x	x	x	x	x	x	x	
0x1A4	CAN_TDT2R	TIME[15:0]														Reserved				TGT	Reserved			DLC[3:0]										
	Reset value	x	x	x	x	x	x	x	x	x	x	x	x	x	x	x	x	x	x	x	x	x	x	x	x	x	x	x	x	x	x	x		
0x1A8	CAN_TDL2R	DATA3[7:0]							DATA2[7:0]							DATA1[7:0]							DATA0[7:0]											
	Reset value	x	x	x	x	x	x	x	x	x	x	x	x	x	x	x	x	x	x	x	x	x	x	x	x	x	x	x	x	x	x	x		
0x1AC	CAN_TDH2R	DATA7[7:0]							DATA6[7:0]							DATA5[7:0]							DATA4[7:0]											
	Reset value	x	x	x	x	x	x	x	x	x	x	x	x	x	x	x	x	x	x	x	x	x	x	x	x	x	x	x	x	x	x	x	x	
0x1B0	CAN_RI0R	STID[10:0]/EXID[28:18]														EXID[17:0]											IDE	RTR	Reserved					
	Reset value	x	x	x	x	x	x	x	x	x	x	x	x	x	x	x	x	x	x	x	x	x	x	x	x	x	x	x	x	x	x	x	x	
0x1B4	CAN_RDT0R	TIME[15:0]														FMI[7:0]							Reserved			DLC[3:0]								
	Reset value	x	x	x	x	x	x	x	x	x	x	x	x	x	x	x	x	x	x	x	x	x	x	x	x	x	x	x	x	x	x	x		
0x1B8	CAN_RDL0R	DATA3[7:0]							DATA2[7:0]							DATA1[7:0]							DATA0[7:0]											
	Reset value	x	x	x	x	x	x	x	x	x	x	x	x	x	x	x	x	x	x	x	x	x	x	x	x	x	x	x	x	x	x	x	x	
0x1BC	CAN_RDH0R	DATA7[7:0]							DATA6[7:0]							DATA5[7:0]							DATA4[7:0]											
	Reset value	x	x	x	x	x	x	x	x	x	x	x	x	x	x	x	x	x	x	x	x	x	x	x	x	x	x	x	x	x	x	x	x	
0x1C0	CAN_RI1R	STID[10:0]/EXID[28:18]														EXID[17:0]											IDE	RTR	Reserved					
	Reset value	x	x	x	x	x	x	x	x	x	x	x	x	x	x	x	x	x	x	x	x	x	x	x	x	x	x	x	x	x	x	x	x	
0x1C4	CAN_RDT1R	TIME[15:0]														FMI[7:0]							Reserved			DLC[3:0]								
	Reset value	x	x	x	x	x	x	x	x	x	x	x	x	x	x	x	x	x	x	x	x	x	x	x	x	x	x	x	x	x	x	x		
0x1C8	CAN_RDL1R	DATA3[7:0]							DATA2[7:0]							DATA1[7:0]							DATA0[7:0]											
	Reset value	x	x	x	x	x	x	x	x	x	x	x	x	x	x	x	x	x	x	x	x	x	x	x	x	x	x	x	x	x	x	x	x	
0x1CC	CAN_RDH1R	DATA7[7:0]							DATA6[7:0]							DATA5[7:0]							DATA4[7:0]											
	Reset value	x	x	x	x	x	x	x	x	x	x	x	x	x	x	x	x	x	x	x	x	x	x	x	x	x	x	x	x	x	x	x	x	
0x1D0-0x1FF	Reserved																																	

Table 178. bxCAN register map and reset values (continued)

Offset	Register	31	30	29	28	27	26	25	24	23	22	21	20	19	18	17	16	15	14	13	12	11	10	9	8	7	6	5	4	3	2	1	0
0x200	CAN_FMR	Reserved													CAN2SB[5:0]					Reserved					FINIT								
	Reset value														0	0	1	1	1	0						1							
0x204	CAN_FM1R	Reserved			FBM[27:0]																												
	Reset value				0	0	0	0	0	0	0	0	0	0	0	0	0	0	0	0	0	0	0	0	0	0	0	0	0	0	0	0	0
0x208	Reserved																																
0x20C	CAN_FS1R	Reserved			FSC[27:0]																												
	Reset value				0	0	0	0	0	0	0	0	0	0	0	0	0	0	0	0	0	0	0	0	0	0	0	0	0	0	0	0	0
0x210	Reserved																																
0x214	CAN_FFA1R	Reserved			FFA[27:0]																												
	Reset value				0	0	0	0	0	0	0	0	0	0	0	0	0	0	0	0	0	0	0	0	0	0	0	0	0	0	0	0	0
0x218	Reserved																																
0x21C	CAN_FA1R	Reserved			FACT[27:0]																												
	Reset value				0	0	0	0	0	0	0	0	0	0	0	0	0	0	0	0	0	0	0	0	0	0	0	0	0	0	0	0	0
0x220	Reserved																																
0x224-0x23F	Reserved																																
0x240	CAN_F0R1	FB[31:0]																															
	Reset value	x	x	x	x	x	x	x	x	x	x	x	x	x	x	x	x	x	x	x	x	x	x	x	x	x	x	x	x	x	x	x	
0x244	CAN_F0R2	FB[31:0]																															
	Reset value	x	x	x	x	x	x	x	x	x	x	x	x	x	x	x	x	x	x	x	x	x	x	x	x	x	x	x	x	x	x	x	
0x248	CAN_F1R1	FB[31:0]																															
	Reset value	x	x	x	x	x	x	x	x	x	x	x	x	x	x	x	x	x	x	x	x	x	x	x	x	x	x	x	x	x	x	x	
0x24C	CAN_F1R2	FB[31:0]																															
	Reset value	x	x	x	x	x	x	x	x	x	x	x	x	x	x	x	x	x	x	x	x	x	x	x	x	x	x	x	x	x	x	x	
.	.																																
.	.																																
.	.																																
.	.																																
0x318	CAN_F27R1	FB[31:0]																															
	Reset value	x	x	x	x	x	x	x	x	x	x	x	x	x	x	x	x	x	x	x	x	x	x	x	x	x	x	x	x	x	x	x	
0x31C	CAN_F27R2	FB[31:0]																															
	Reset value	x	x	x	x	x	x	x	x	x	x	x	x	x	x	x	x	x	x	x	x	x	x	x	x	x	x	x	x	x	x	x	

## 24 Serial peripheral interface (SPI)

**Low-density devices** are STM32F101xx, STM32F102xx and STM32F103xx microcontrollers where the Flash memory density ranges between 16 and 32 Kbytes.

**Medium-density devices** are STM32F101xx, STM32F102xx and STM32F103xx microcontrollers where the Flash memory density ranges between 64 and 128 Kbytes.

**High-density devices** are STM32F101xx and STM32F103xx microcontrollers where the Flash memory density ranges between 256 and 512 Kbytes.

**XL-density devices** are STM32F101xx and STM32F103xx microcontrollers where the Flash memory density ranges between 768 Kbytes and 1 Mbyte.

**Connectivity line devices** are STM32F105xx and STM32F107xx microcontrollers.

This section applies to the whole STM32F10xxx family, unless otherwise specified.

### 24.1 SPI introduction

In high-density, XL-density and connectivity line devices, the SPI interface gives the flexibility to get either the SPI protocol or the I<sup>2</sup>S audio protocol. By default, it is the SPI function that is selected. It is possible to switch the interface from SPI to I<sup>2</sup>S by software. In low- and medium-density devices, the I<sup>2</sup>S protocol is not available.

The serial peripheral interface (SPI) allows half/ full-duplex, synchronous, serial communication with external devices. The interface can be configured as the master and in this case it provides the communication clock (SCK) to the external slave device. The interface is also capable of operating in multimaster configuration.

It may be used for a variety of purposes, including Simplex synchronous transfers on two lines with a possible bidirectional data line or reliable communication using CRC checking.

I<sup>2</sup>S is also a synchronous, serial communication interface with a 3-pin protocol. It can address four different audio standards including the I<sup>2</sup>S Phillips standard, the MSB- and LSB-justified standards and the PCM standard. It can operate in slave or master mode with half-duplex communication. Master clock may be provided by the interface to an external slave component when the I<sup>2</sup>S is configured as the communication master.

---

**Warning:** Since some SPI3/I2S3 pins are shared with JTAG pins (SPI3\_NSS/I2S3\_WS with JTDI and SPI3\_SCK/I2S3\_CK with JTDO), they are not controlled by the IO controller and are reserved for JTAG usage (after each Reset). For this purpose, prior to configure the SPI3/I2S3 pins, the user has to disable the JTAG and use the SWD interface (when debugging the application), or disable both JTAG/SWD interfaces (for standalone applications). For more information on the configuration of JTAG/SWD interface pins, please refer to [Section 8.3.5: JTAG/SWD alternate function remapping](#).

---

## 24.2 SPI and I<sup>2</sup>S main features

### 24.2.1 SPI features

- Full-duplex synchronous transfers on three lines
- Simplex synchronous transfers on two lines with or without a bidirectional data line
- 8- or 16-bit transfer frame format selection
- Master or slave operation
- Multimaster mode capability
- 8 master mode baud rate prescalers ( $f_{PCLK}/2$  max.)
- Slave mode frequency ( $f_{PCLK}/2$  max)
- Faster communication for both master and slave
- NSS management by hardware or software for both master and slave: dynamic change of master/slave operations
- Programmable clock polarity and phase
- Programmable data order with MSB-first or LSB-first shifting
- Dedicated transmission and reception flags with interrupt capability
- SPI bus busy status flag
- Hardware CRC feature for reliable communication:
  - CRC value can be transmitted as last byte in Tx mode
  - Automatic CRC error checking for last received byte
- Master mode fault, overrun and CRC error flags with interrupt capability
- 1-byte transmission and reception buffer with DMA capability: Tx and Rx requests

## 24.2.2 I<sup>2</sup>S features

- Simplex communication (only transmitter or receiver)
- Master or slave operations
- 8-bit programmable linear prescaler to reach accurate audio sample frequencies (from 8 kHz to 96 kHz)
- Data format may be 16-bit, 24-bit or 32-bit
- Packet frame is fixed to 16-bit (16-bit data frame) or 32-bit (16-bit, 24-bit, 32-bit data frame) by audio channel
- Programmable clock polarity (steady state)
- Underrun flag in slave transmission mode and Overrun flag in reception mode (master and slave)
- 16-bit register for transmission and reception with one data register for both channel sides
- Supported I<sup>2</sup>S protocols:
  - I<sup>2</sup>S Phillips standard
  - MSB-Justified standard (Left-Justified)
  - LSB-Justified standard (Right-Justified)
  - PCM standard (with short and long frame synchronization on 16-bit channel frame or 16-bit data frame extended to 32-bit channel frame)
- Data direction is always MSB first
- DMA capability for transmission and reception (16-bit wide)
- Master clock may be output to drive an external audio component. Ratio is fixed at  $256 \times F_S$  (where  $F_S$  is the audio sampling frequency)
- In connectivity line devices, both I<sup>2</sup>S (I2S2 and I2S3) have a dedicated PLL (PLL3) to generate an even more accurate clock.

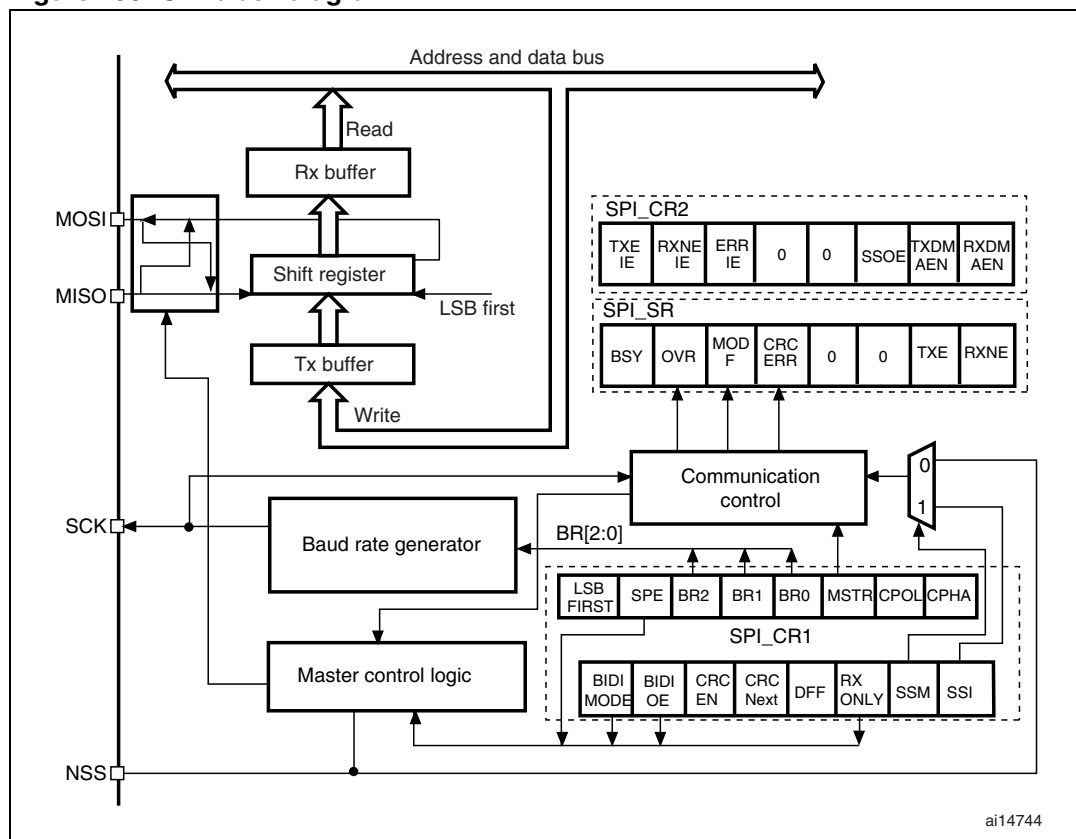


## 24.3 SPI functional description

### 24.3.1 General description

The block diagram of the SPI is shown in [Figure 236](#).

**Figure 236. SPI block diagram**

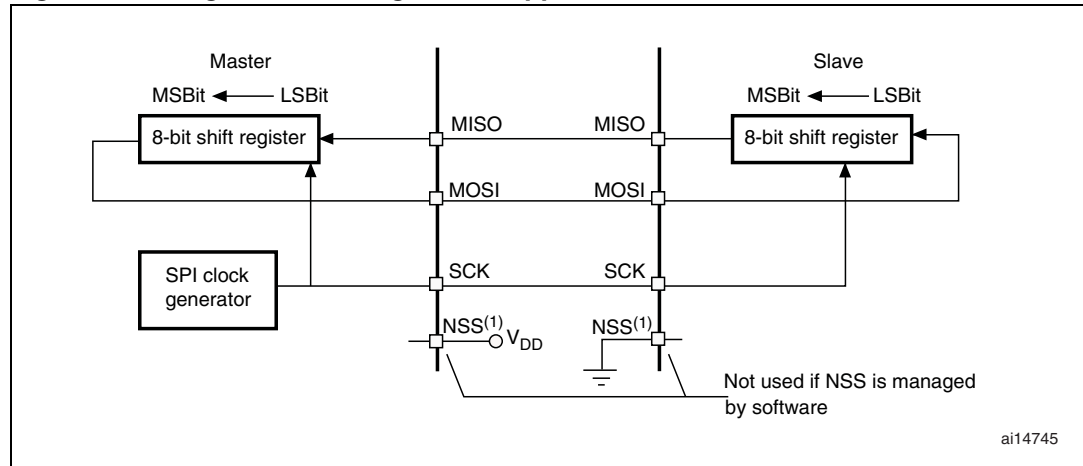


Usually, the SPI is connected to external devices through 4 pins:

- **MISO:** Master In / Slave Out data. This pin can be used to transmit data in slave mode and receive data in master mode.
- **MOSI:** Master Out / Slave In data. This pin can be used to transmit data in master mode and receive data in slave mode.
- **SCK:** Serial Clock output for SPI masters and input for SPI slaves.
- **NSS:** Slave select. This is an optional pin to select a slave device. This pin acts as a 'chip select' to let the SPI master communicate with slaves individually and to avoid contention on the data lines. Slave NSS inputs can be driven by standard IO ports on the master device. The NSS pin may also be used as an output if enabled (SSOE bit) and driven low if the SPI is in master configuration. In this manner, all NSS pins from devices connected to the Master NSS pin see a low level and become slaves when they are configured in NSS hardware mode. When configured in master mode with NSS configured as an input (MSTR=1 and SSOE=0) and if NSS is pulled low, the SPI enters the master mode fault state: the MSTR bit is automatically cleared and the device is configured in slave mode (refer to [Section 24.3.10: Error flags on page 674](#)).

A basic example of interconnections between a single master and a single slave is illustrated in [Figure 237](#).

**Figure 237. Single master/ single slave application**



1. Here, the NSS pin is configured as an input.

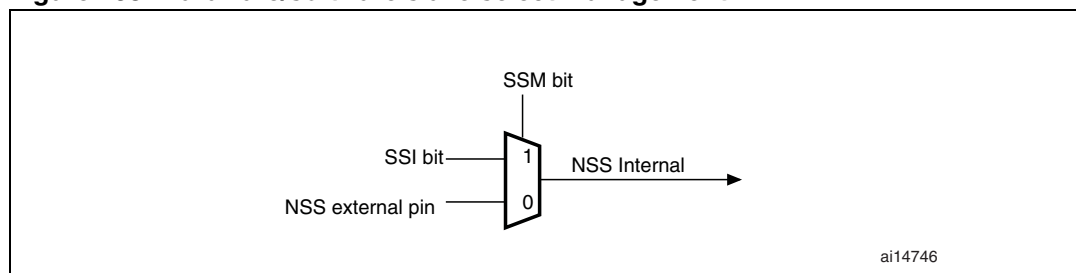
The MOSI pins are connected together and the MISO pins are connected together. In this way data is transferred serially between master and slave (most significant bit first).

The communication is always initiated by the master. When the master device transmits data to a slave device via the MOSI pin, the slave device responds via the MISO pin. This implies full-duplex communication with both data out and data in synchronized with the same clock signal (which is provided by the master device via the SCK pin).

### Slave select (NSS) pin management

There are two NSS modes:

- Software NSS mode: this mode is enabled by setting the SSM bit in the SPI\_CR1 register (see [Figure 238](#)). In this mode, the external NSS pin is free for other application uses and the internal NSS signal level is driven by writing to the SSI bit in the SPI\_CR1 register.
- Hardware NSS mode: there are two cases:
  - NSS output is enabled: when the STM32F10xxx are operating as a Master and the NSS output is enabled through the SSOE bit in the SPI\_CR2 register, the NSS pin is driven low and all the NSS pins of devices connected to the Master NSS pin see a low level and become slaves when they are configured in NSS hardware mode. When an SPI wants to broadcast a message, it has to pull NSS low to inform all others that there is now a master for the bus. If it fails to pull NSS low, this means that there is another master communicating, and a Hard Fault error occurs.
  - NSS output is disabled: the multimaster capability is allowed.

**Figure 238. Hardware/software slave select management**

### Clock phase and clock polarity

Four possible timing relationships may be chosen by software, using the CPOL and CPHA bits in the SPI\_CR1 register. The CPOL (clock polarity) bit controls the steady state value of the clock when no data is being transferred. This bit affects both master and slave modes. If CPOL is reset, the SCK pin has a low-level idle state. If CPOL is set, the SCK pin has a high-level idle state.

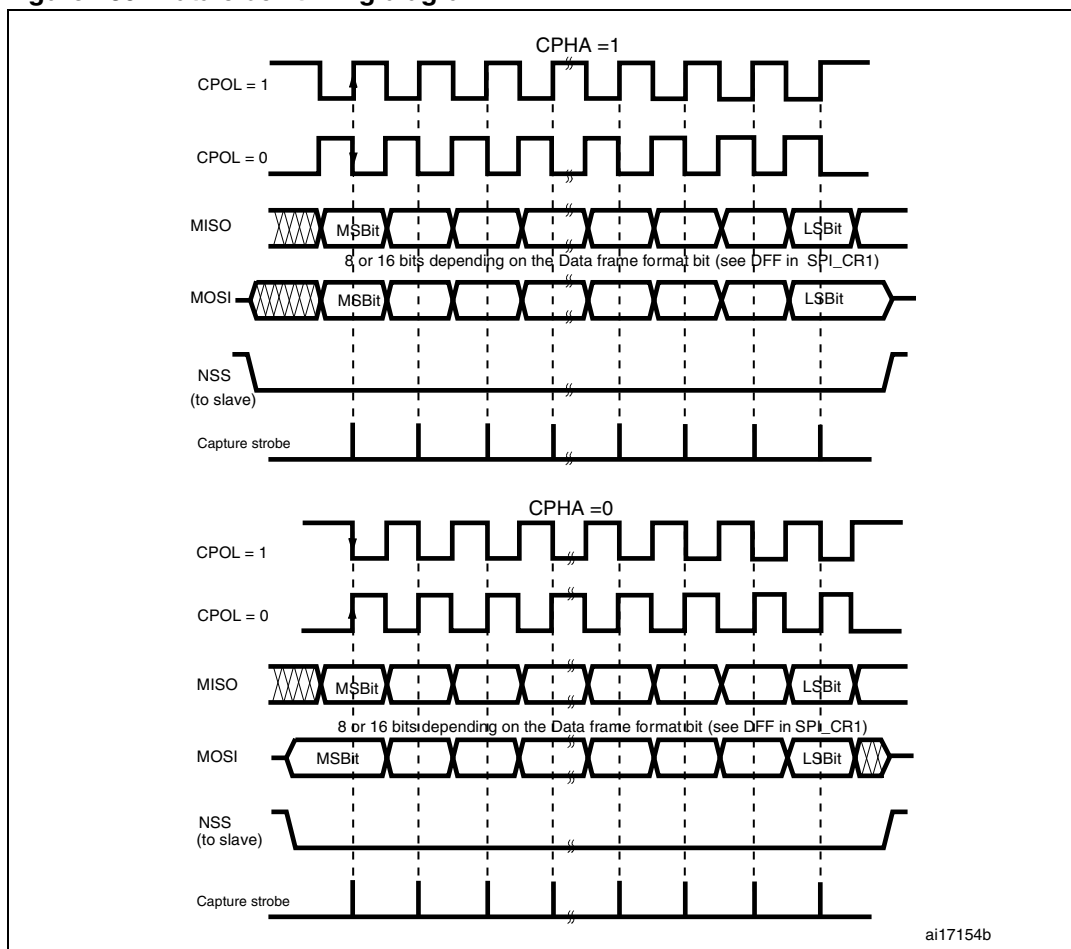
If the CPHA (clock phase) bit is set, the second edge on the SCK pin (falling edge if the CPOL bit is reset, rising edge if the CPOL bit is set) is the MSBit capture strobe. Data are latched on the occurrence of the second clock transition. If the CPHA bit is reset, the first edge on the SCK pin (falling edge if CPOL bit is set, rising edge if CPOL bit is reset) is the MSBit capture strobe. Data are latched on the occurrence of the first clock transition.

The combination of the CPOL (clock polarity) and CPHA (clock phase) bits selects the data capture clock edge.

[Figure 239](#), shows an SPI transfer with the four combinations of the CPHA and CPOL bits. The diagram may be interpreted as a master or slave timing diagram where the SCK pin, the MISO pin, the MOSI pin are directly connected between the master and the slave device.

- Note:**
- 1 Prior to changing the CPOL/CPHA bits the SPI must be disabled by resetting the SPE bit.
  - 2 Master and slave must be programmed with the same timing mode.
  - 3 The idle state of SCK must correspond to the polarity selected in the SPI\_CR1 register (by pulling up SCK if CPOL=1 or pulling down SCK if CPOL=0).
  - 4 The Data Frame Format (8- or 16-bit) is selected through the DFF bit in SPI\_CR1 register, and determines the data length during transmission/reception.

Figure 239. Data clock timing diagram



1. These timings are shown with the LSBFIRST bit reset in the SPI\_CR1 register.

### Data frame format

Data can be shifted out either MSB-first or LSB-first depending on the value of the LSBFIRST bit in the SPI\_CR1 Register.

Each data frame is 8 or 16 bits long depending on the size of the data programmed using the DFF bit in the SPI\_CR1 register. The selected data frame format is applicable for transmission and/or reception.

### 24.3.2 Configuring the SPI in slave mode

In the slave configuration, the serial clock is received on the SCK pin from the master device. The value set in the BR[2:0] bits in the SPI\_CR1 register, does not affect the data transfer rate.

*Note: It is recommended to enable the SPI slave before the master sends the clock. If not, undesired data transmission might occur. The data register of the slave needs to be ready before the first edge of the communication clock or before the end of the ongoing communication. It is mandatory to have the polarity of the communication clock set to the steady state value before the slave and the master are enabled.*

Follow the procedure below to configure the SPI in slave mode:

### Procedure

1. Set the DFF bit to define 8- or 16-bit data frame format
2. Select the CPOL and CPHA bits to define one of the four relationships between the data transfer and the serial clock (see [Figure 239](#)). For correct data transfer, the CPOL and CPHA bits must be configured in the same way in the slave device and the master device.
3. The frame format (MSB-first or LSB-first depending on the value of the LSBFIRST bit in the SPI\_CR1 register) must be the same as the master device.
4. In Hardware mode (refer to [Slave select \(NSS\) pin management on page 658](#)), the NSS pin must be connected to a low level signal during the complete byte transmit sequence. In NSS software mode, set the SSM bit and clear the SSI bit in the SPI\_CR1 register.
5. Clear the MSTR bit and set the SPE bit (both in the SPI\_CR1 register) to assign the pins to alternate functions.

In this configuration the MOSI pin is a data input and the MISO pin is a data output.

### Transmit sequence

The data byte is parallel-loaded into the Tx buffer during a write cycle.

The transmit sequence begins when the slave device receives the clock signal and the most significant bit of the data on its MOSI pin. The remaining bits (the 7 bits in 8-bit data frame format, and the 15 bits in 16-bit data frame format) are loaded into the shift-register. The TXE flag in the SPI\_SR register is set on the transfer of data from the Tx Buffer to the shift register and an interrupt is generated if the TXEIE bit in the SPI\_CR2 register is set.

### Receive sequence

For the receiver, when data transfer is complete:

- The Data in shift register is transferred to Rx Buffer and the RXNE flag (SPI\_SR register) is set
- An Interrupt is generated if the RXNEIE bit is set in the SPI\_CR2 register.

After the last sampling clock edge the RXNE bit is set, a copy of the data byte received in the shift register is moved to the Rx buffer. When the SPI\_DR register is read, the SPI peripheral returns this buffered value.

Clearing of the RXNE bit is performed by reading the SPI\_DR register.

## 24.3.3 Configuring the SPI in master mode

In the master configuration, the serial clock is generated on the SCK pin.

### Procedure

1. Select the BR[2:0] bits to define the serial clock baud rate (see SPI\_CR1 register).
2. Select the CPOL and CPHA bits to define one of the four relationships between the data transfer and the serial clock (see [Figure 239](#)).
3. Set the DFF bit to define 8- or 16-bit data frame format
4. Configure the LSBFIRST bit in the SPI\_CR1 register to define the frame format
5. If the NSS pin is required in input mode, in hardware mode, connect the NSS pin to a high-level signal during the complete byte transmit sequence. In NSS software mode,

set the SSM and SSI bits in the SPI\_CR1 register.

If the NSS pin is required in output mode, the SSOE bit only should be set.

6. The MSTR and SPE bits must be set (they remain set only if the NSS pin is connected to a high-level signal).

In this configuration the MOSI pin is a data output and the MISO pin is a data input.

### Transmit sequence

The transmit sequence begins when a byte is written in the Tx Buffer.

The data byte is parallel-loaded into the shift register (from the internal bus) during the first bit transmission and then shifted out serially to the MOSI pin MSB first or LSB first depending on the LSBFIRST bit in the SPI\_CR1 register. The TXE flag is set on the transfer of data from the Tx Buffer to the shift register and an interrupt is generated if the TXEIE bit in the SPI\_CR2 register is set.

### Receive sequence

For the receiver, when data transfer is complete:

- The data in the shift register is transferred to the RX Buffer and the RXNE flag is set
- An interrupt is generated if the RXNEIE bit is set in the SPI\_CR2 register

At the last sampling clock edge the RXNE bit is set, a copy of the data byte received in the shift register is moved to the Rx buffer. When the SPI\_DR register is read, the SPI peripheral returns this buffered value.

Clearing the RXNE bit is performed by reading the SPI\_DR register.

A continuous transmit stream can be maintained if the next data to be transmitted is put in the Tx buffer once the transmission is started. Note that TXE flag should be '1 before any attempt to write the Tx buffer is made.

*Note: In the NSS hardware mode, the slave's NSS input is controlled by the NSS pin or another GPIO pin that has to be controlled by software.*

## 24.3.4 Configuring the SPI for Simplex communication

The SPI is capable of operating in simplex mode in 2 configurations.

- 1 clock and 1 bidirectional data wire
- 1 clock and 1 data wire (receive-only or transmit-only)

### 1 clock and 1 bidirectional data wire (BIDIMODE=1)

This mode is enabled by setting the BIDIMODE bit in the SPI\_CR1 register. In this mode SCK is used for the clock and MOSI in master or MISO in slave mode is used for data communication. The transfer direction (Input/Output) is selected by the BIDIOE bit in the SPI\_CR1 register. When this bit is 1, the data line is output otherwise it is input.

### 1 clock and 1 unidirectional data wire (BIDIMODE=0)

In this mode, the application can use the SPI either in transmit-only mode or in receive-only mode.

- Transmit-only mode is similar to full-duplex mode (BIDIMODE=0, RXONLY=0): the data are transmitted on the transmit pin (MOSI in master mode or MISO in slave mode) and the receive pin (MISO in master mode or MOSI in slave mode) can be used as a

general-purpose IO. In this case, the application just needs to ignore the Rx buffer (if the data register is read, it does not contain the received value).

- In receive-only mode, the application can disable the SPI output function by setting the RXONLY bit in the SPI\_CR2 register. In this case, it frees the transmit IO pin (MOSI in master mode or MISO in slave mode), so it can be used for other purposes.

To start the communication in receive-only mode, configure and enable the SPI:

- In master mode, the communication starts immediately and stops when the SPE bit is cleared and the current reception stops. There is no need to read the BSY flag in this mode. It is always set when an SPI communication is ongoing.
- In slave mode, the SPI continues to receive as long as the NSS is pulled down (or the SSI bit is cleared in NSS software mode) and the SCK is running.

### 24.3.5 Data transmission and reception procedures

#### Rx and Tx buffers

In reception, data are received and then stored into an internal Rx buffer while In transmission, data are first stored into an internal Tx buffer before being transmitted.

A read access of the SPI\_DR register returns the Rx buffered value whereas a write access to the SPI\_DR stores the written data into the Tx buffer.

#### Start sequence in master mode

- In full-duplex (BIDIMODE=0 and RXONLY=0)
  - The sequence begins when data are written into the SPI\_DR register (Tx buffer).
  - The data are then parallel loaded from the Tx buffer into the 8-bit shift register during the first bit transmission and then shifted out serially to the MOSI pin.
  - At the same time, the received data on the MISO pin is shifted in serially to the 8-bit shift register and then parallel loaded into the SPI\_DR register (Rx buffer).
- In unidirectional receive-only mode (BIDIMODE=0 and RXONLY=1)
  - The sequence begins as soon as SPE=1
  - Only the receiver is activated and the received data on the MISO pin are shifted in serially to the 8-bit shift register and then parallel loaded into the SPI\_DR register (Rx buffer).
- In bidirectional mode, when transmitting (BIDIMODE=1 and BIDIOE=1)
  - The sequence begins when data are written into the SPI\_DR register (Tx buffer).
  - The data are then parallel loaded from the Tx buffer into the 8-bit shift register during the first bit transmission and then shifted out serially to the MOSI pin.
  - No data are received.
- In bidirectional mode, when receiving (BIDIMODE=1 and BIDIOE=0)
  - The sequence begins as soon as SPE=1 and BIDIOE=0.
  - The received data on the MOSI pin are shifted in serially to the 8-bit shift register and then parallel loaded into the SPI\_DR register (Rx buffer).
  - The transmitter is not activated and no data are shifted out serially to the MOSI pin.

### Start sequence in slave mode

- In full-duplex mode (BIDIMODE=0 and RXONLY=0)
  - The sequence begins when the slave device receives the clock signal and the first bit of the data on its MOSI pin. The 7 remaining bits are loaded into the shift register.
  - At the same time, the data are parallel loaded from the Tx buffer into the 8-bit shift register during the first bit transmission, and then shifted out serially to the MISO pin. The software must have written the data to be sent before the SPI master device initiates the transfer.
- In unidirectional receive-only mode (BIDIMODE=0 and RXONLY=1)
  - The sequence begins when the slave device receives the clock signal and the first bit of the data on its MOSI pin. The 7 remaining bits are loaded into the shift register.
  - The transmitter is not activated and no data are shifted out serially to the MISO pin.
- In bidirectionnal mode, when transmitting (BIDIMODE=1 and BIDIOE=1)
  - The sequence begins when the slave device receives the clock signal and the first bit in the Tx buffer is transmitted on the MISO pin.
  - The data are then parallel loaded from the Tx buffer into the 8-bit shift register during the first bit transmission and then shifted out serially to the MISO pin. The software must have written the data to be sent before the SPI master device initiates the transfer.
  - No data are received.
- In bidirectionnal mode, when receiving (BIDIMODE=1 and BIDIOE=0)
  - The sequence begins when the slave device receives the clock signal and the first bit of the data on its MISO pin.
  - The received data on the MISO pin are shifted in serially to the 8-bit shift register and then parallel loaded into the SPI\_DR register (Rx buffer).
  - The transmitter is not activated and no data are shifted out serially to the MISO pin.

### Handling data transmission and reception

The TXE flag (Tx buffer empty) is set when the data are transferred from the Tx buffer to the shift register. It indicates that the internal Tx buffer is ready to be loaded with the next data. An interrupt can be generated if the TXEIE bit in the SPI\_CR2 register is set. Clearing the TXE bit is performed by writing to the SPI\_DR register.

*Note:* The software must ensure that the TXE flag is set to 1 before attempting to write to the Tx buffer. Otherwise, it overwrites the data previously written to the Tx buffer.

The RXNE flag (Rx buffer not empty) is set on the last sampling clock edge, when the data are transferred from the shift register to the Rx buffer. It indicates that data are ready to be read from the SPI\_DR register. An interrupt can be generated if the RXNEIE bit in the SPI\_CR2 register is set. Clearing the RXNE bit is performed by reading the SPI\_DR register.

For some configurations, the BSY flag can be used during the last data transfer to wait until the completion of the transfer.



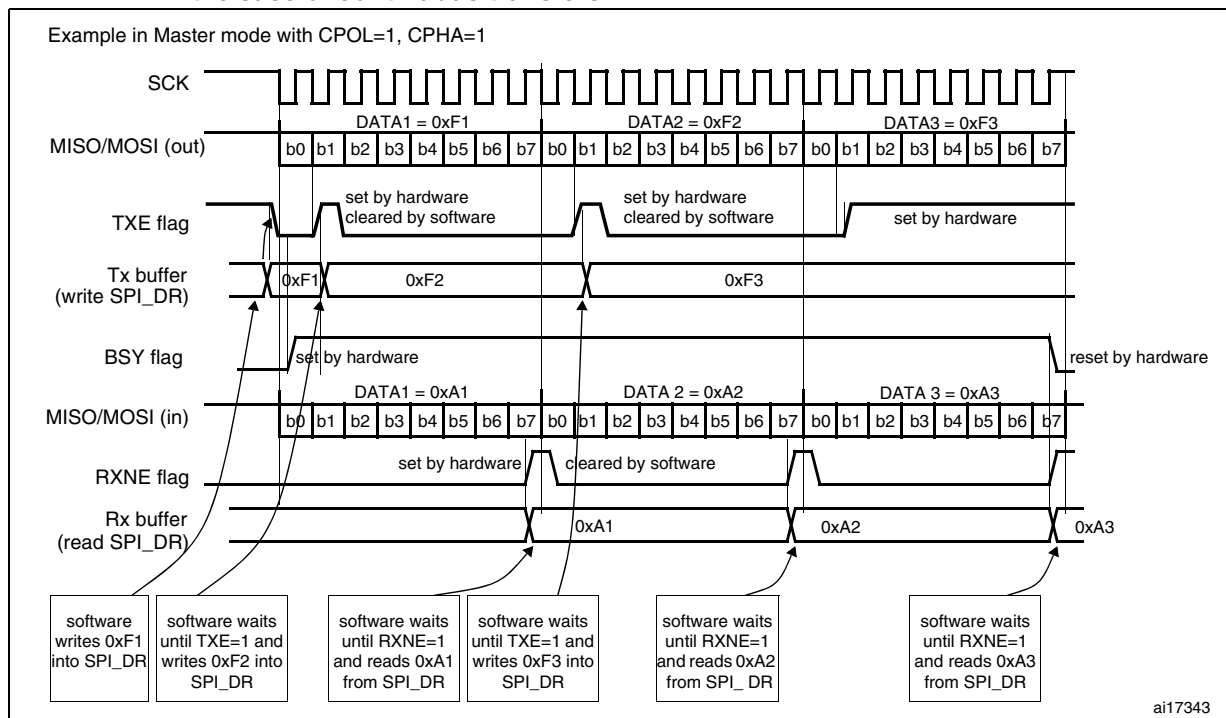
**Full-duplex transmit and receive procedure in master or slave mode (BIDIMODE=0 and RXONLY=0)**

The software has to follow this procedure to transmit and receive data (see [Figure 240](#) and [Figure 241](#)):

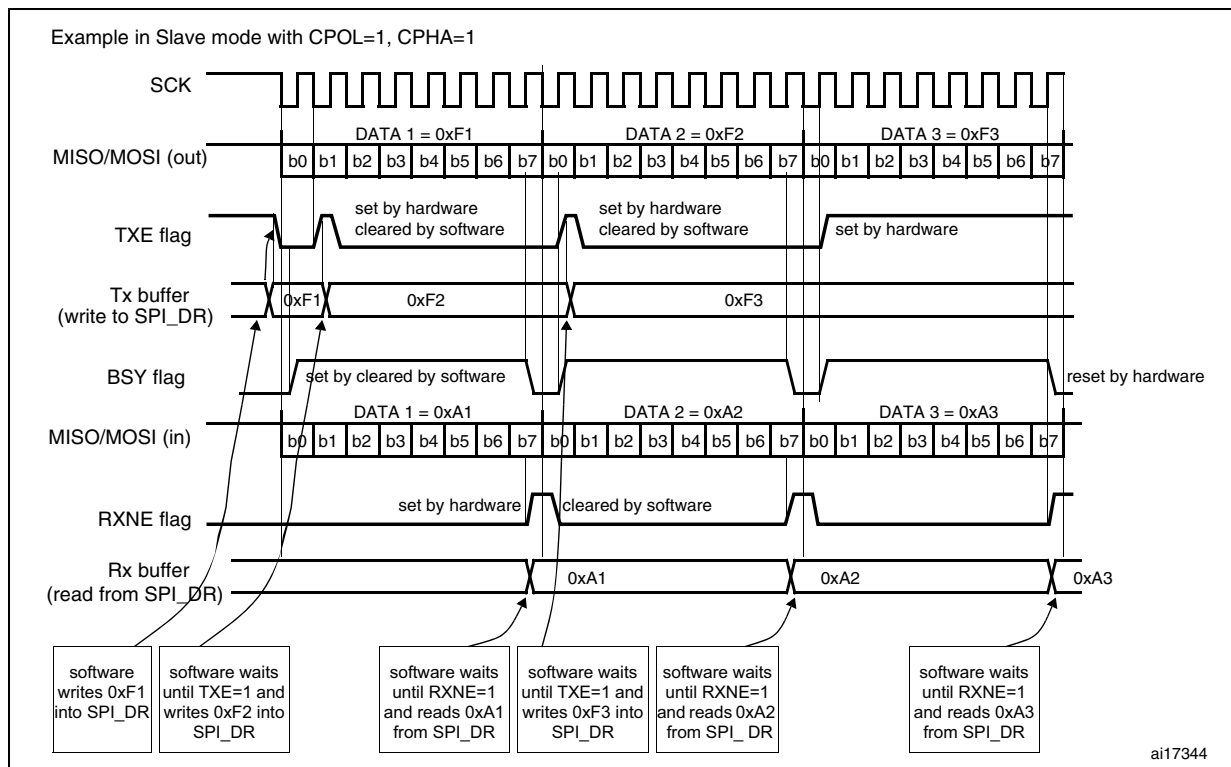
1. Enable the SPI by setting the SPE bit to 1.
2. Write the first data item to be transmitted into the SPI\_DR register (this clears the TXE flag).
3. Wait until TXE=1 and write the second data item to be transmitted. Then wait until RXNE=1 and read the SPI\_DR to get the first received data item (this clears the RXNE bit). Repeat this operation for each data item to be transmitted/received until the n-1 received data.
4. Wait until RXNE=1 and read the last received data.
5. Wait until TXE=1 and then wait until BSY=0 before disabling the SPI.

This procedure can also be implemented using dedicated interrupt subroutines launched at each rising edges of the RXNE or TXE flag.

**Figure 240. TXE/RXNE/BSY behavior in Master / full-duplex mode (BIDIMODE=0 and RXONLY=0) in the case of continuous transfers**



**Figure 241. TXE/RXNE/BSY behavior in Slave / full-duplex mode (BIDIMODE=0, RXONLY=0) in the case of continuous transfers**



**Transmit-only procedure (BIDIMODE=0 RXONLY=0)**

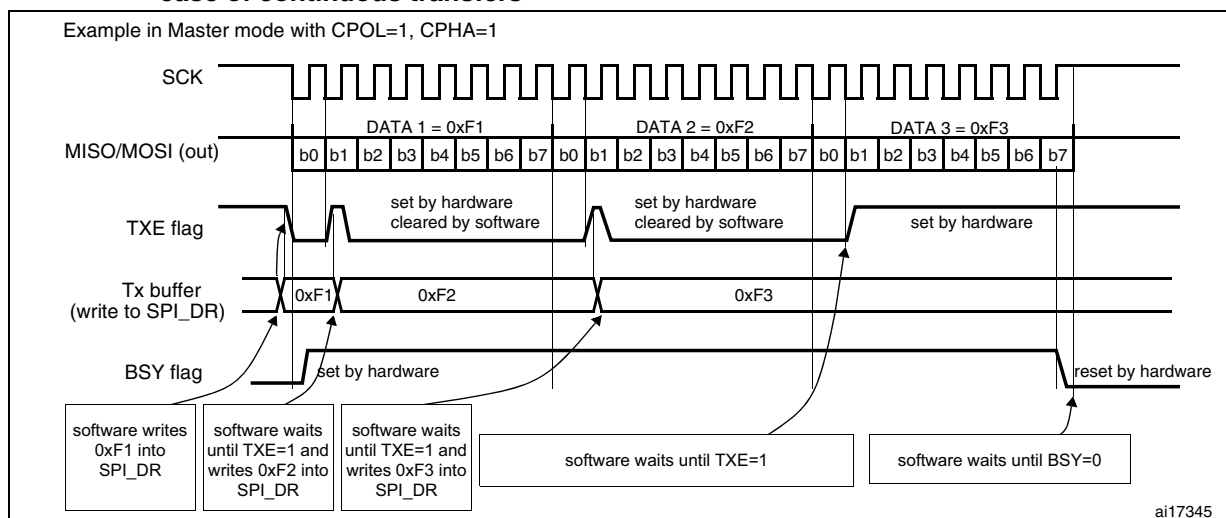
In this mode, the procedure can be reduced as described below and the BSY bit can be used to wait until the completion of the transmission (see [Figure 242](#) and [Figure 243](#)).

1. Enable the SPI by setting the SPE bit to 1.
2. Write the first data item to send into the SPI\_DR register (this clears the TXE bit).
3. Wait until TXE=1 and write the next data item to be transmitted. Repeat this step for each data item to be transmitted.
4. After writing the last data item into the SPI\_DR register, wait until TXE=1, then wait until BSY=0, this indicates that the transmission of the last data is complete.

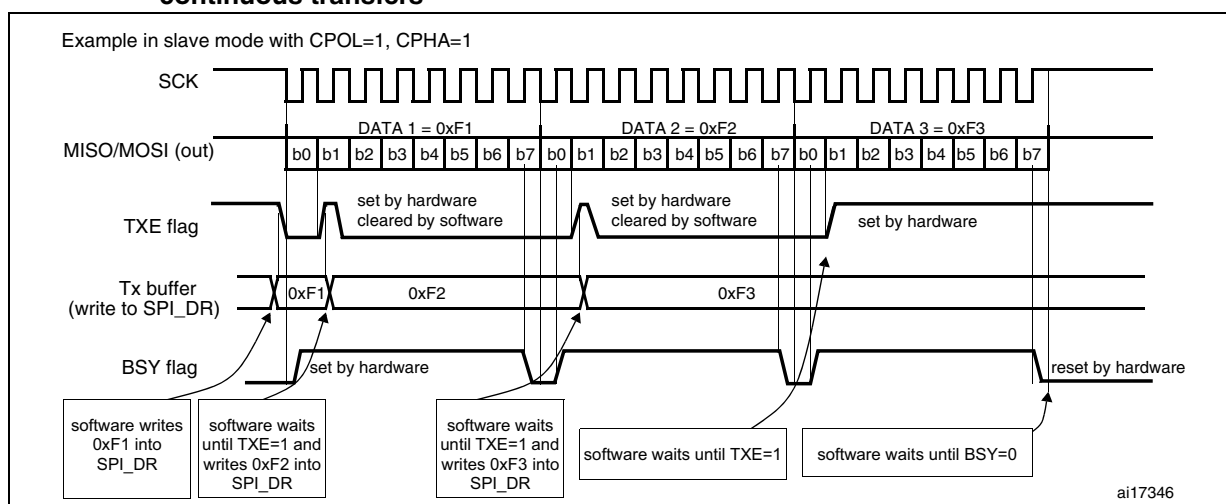
This procedure can be also implemented using dedicated interrupt subroutines launched at each rising edge of the TXE flag.

- Note:*
- 1 During discontinuous communications, there is a 2 APB clock period delay between the write operation to SPI\_DR and the BSY bit setting. As a consequence, in transmit-only mode, it is mandatory to wait first until TXE is set and then until BSY is cleared after writing the last data.
  - 2 After transmitting two data items in transmit-only mode, the OVR flag is set in the SPI\_SR register since the received data are never read.

**Figure 242. TXE/BSY behavior in Master transmit-only mode (BIDIMODE=0 and RXONLY=0) in the case of continuous transfers**



**Figure 243. TXE/BSY in Slave transmit-only mode (BIDIMODE=0 and RXONLY=0) in the case of continuous transfers**



**Bidirectional transmit procedure (BIDIMODE=1 and BIDIOE=1)**

In this mode, the procedure is similar to the procedure in Transmit-only mode except that the BIDIMODE and BIDIOE bits both have to be set in the SPI\_CR2 register before enabling the SPI.

**Unidirectional receive-only procedure (BIDIMODE=0 and RXONLY=1)**

In this mode, the procedure can be reduced as described below (see [Figure 244](#)):

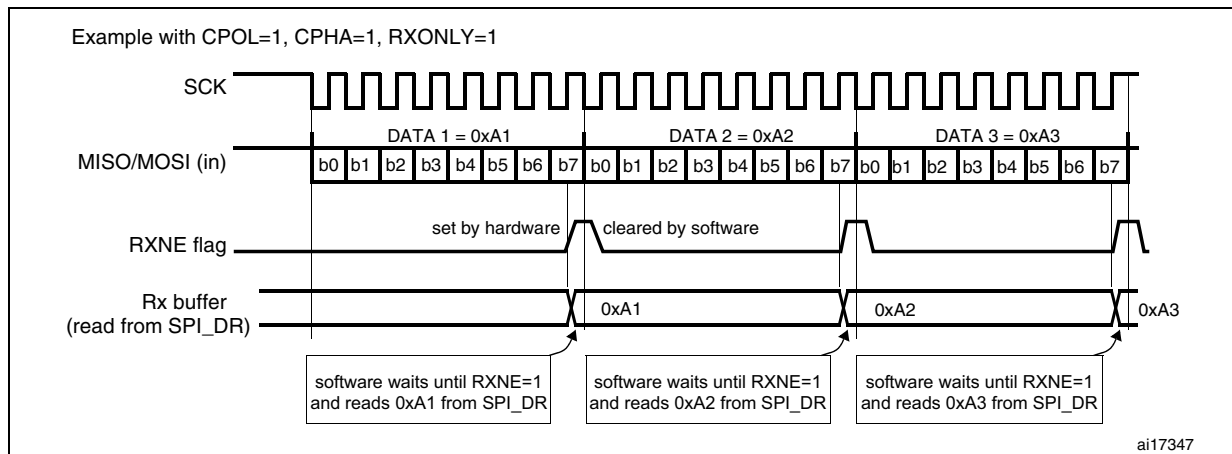
1. Set the RXONLY bit in the SPI\_CR2 register.
2. Enable the SPI by setting the SPE bit to 1:
  - a) In master mode, this immediately activates the generation of the SCK clock, and data are serially received until the SPI is disabled (SPE=0).
  - b) In slave mode, data are received when the SPI master device drives NSS low and generates the SCK clock.

- Wait until  $RXNE=1$  and read the SPI\_DR register to get the received data (this clears the RXNE bit). Repeat this operation for each data item to be received.

This procedure can also be implemented using dedicated interrupt subroutines launched at each rising edge of the RXNE flag.

*Note:* If it is required to disable the SPI after the last transfer, follow the recommendation described in [Section 24.3.8: Disabling the SPI on page 671](#).

**Figure 244. RXNE behavior in receive-only mode (BIDIRMODE=0 and RXONLY=1) in the case of continuous transfers**



### Bidirectional receive procedure (BIDIMODE=1 and BIDIOE=0)

In this mode, the procedure is similar to the Receive-only mode procedure except that the BIDIMODE bit has to be set and the BIDIOE bit cleared in the SPI\_CR2 register before enabling the SPI.

### Continuous and discontinuous transfers

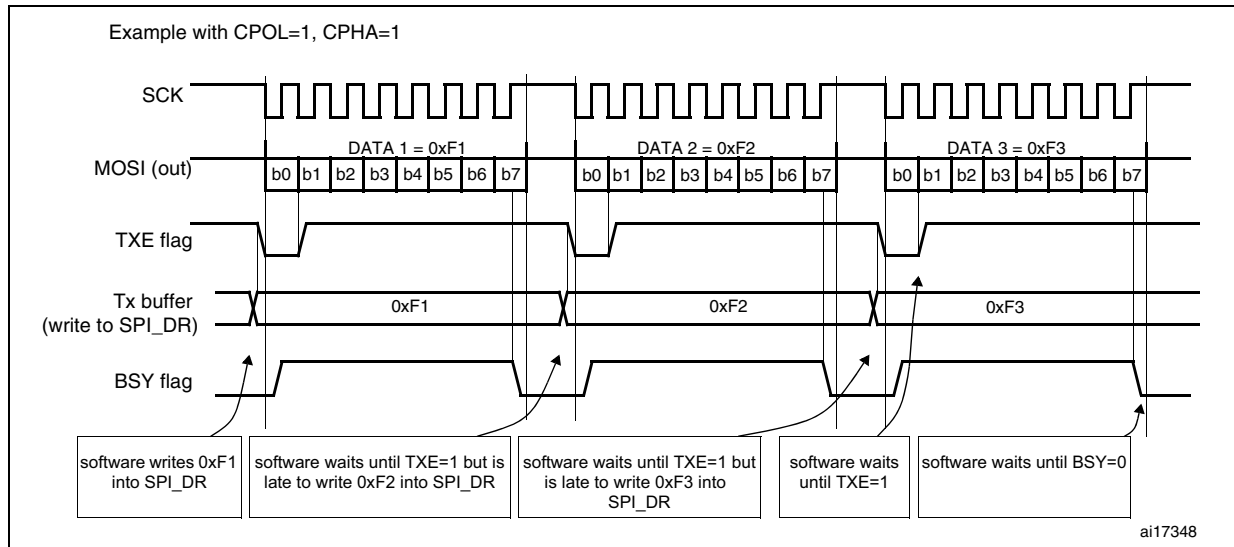
When transmitting data in master mode, if the software is fast enough to detect each rising edge of TXE (or TXE interrupt) and to immediately write to the SPI\_DR register before the ongoing data transfer is complete, the communication is said to be continuous. In this case, there is no discontinuity in the generation of the SPI clock between each data item and the BSY bit is never cleared between each data transfer.

On the contrary, if the software is not fast enough, this can lead to some discontinuities in the communication. In this case, the BSY bit is cleared between each data transmission (see [Figure 245](#)).

In Master receive-only mode (RXONLY=1), the communication is always continuous and the BSY flag is always read at 1.

In slave mode, the continuity of the communication is decided by the SPI master device. In any case, even if the communication is continuous, the BSY flag goes low between each transfer for a minimum duration of one SPI clock cycle (see [Figure 243](#)).

**Figure 245. TXE/BSY behavior when transmitting (BIDIRMODE=0 and RXONLY=0) in the case of discontinuous transfers**



### 24.3.6 CRC calculation

A CRC calculator has been implemented for communication reliability. Separate CRC calculators are implemented for transmitted data and received data. The CRC is calculated using a programmable polynomial serially on each bit. It is calculated on the sampling clock edge defined by the CPHA and CPOL bits in the SPI\_CR1 register.

*Note:* This SPI offers two kinds of CRC calculation standard which depend directly on the data frame format selected for the transmission and/or reception: 8-bit data (CR8) and 16-bit data (CRC16).

CRC calculation is enabled by setting the CRCEN bit in the SPI\_CR1 register. This action resets the CRC registers (SPI\_RXCRCR and SPI\_TXCRCR). When the CRCNEXT bit in SPI\_CR1 is set, the SPI\_TXCRCR value is transmitted at the end of the current byte transmission.

The CRCERR flag in the SPI\_SR register is set if the value received in the shift register during the SPI\_TXCRCR value transmission does not match the SPI\_RXCRCR value.

If data are present in the TX buffer, the CRC value is transmitted only after the transmission of the data byte. During CRC transmission, the CRC calculator is switched off and the register value remains unchanged.

*Note:* Please refer to the product specifications for availability of this feature.

SPI communication using CRC is possible through the following procedure:

- Program the CPOL, CPHA, LSBFirst, BR, SSM, SSI and MSTR values
- Program the polynomial in the SPI\_CRCPR register
- Enable the CRC calculation by setting the CRCEN bit in the SPI\_CR1 register. This also clears the SPI\_RXCRCR and SPI\_TXCRCR registers
- Enable the SPI by setting the SPE bit in the SPI\_CR1 register
- Start the communication and sustain the communication until all but one byte or half-word have been transmitted or received.
- On writing the last byte or half-word to the TX buffer, set the CRCNext bit in the SPI\_CR1 register to indicate that after transmission of the last byte, the CRC should be transmitted. CRC calculation is frozen during the CRC transmission.
- After transmitting the last byte or half word, the SPI transmits the CRC. The CRCNEXT bit is reset. The CRC is also received and compared against the SPI\_RXCRCR value. If the value does not match, the CRCERR flag in SPI\_SR is set and an interrupt can be generated when the ERRIE bit in the SPI\_CR2 register is set.

*Note:* When the SPI is in slave mode, be careful to enable CRC calculation only when the clock is stable, that is, when the clock is in the steady state. If not, a wrong CRC calculation may be done. In fact, the CRC is sensitive to the SCK slave input clock as soon as CRCEN is set, and this, whatever the value of the SPE bit.

*With high bitrate frequencies, be careful when transmitting the CRC. As the number of used CPU cycles has to be as low as possible in the CRC transfer phase, it is forbidden to call software functions in the CRC transmission sequence to avoid errors in the last data and CRC reception. In fact, CRCNEXT bit has to be written before the end of the transmission/reception of the last data.*

*For high bit rate frequencies, it is advised to use the DMA mode to avoid the degradation of the SPI speed performance due to CPU accesses impacting the SPI bandwidth.*

*When the STM32F10xxx are configured as slaves and the NSS hardware mode is used, the NSS pin needs to be kept low between the data phase and the CRC phase.*

When the SPI is configured in slave mode with the CRC feature enabled, CRC calculation takes place even if a high level is applied on the NSS pin. This may happen for example in case of a multislave environment where the communication master addresses slaves alternately.

Between a slave deselection (high level on NSS) and a new slave selection (low level on NSS), the CRC value should be cleared on both master and slave sides in order to resynchronize the master and slave for their respective CRC calculation.

To clear the CRC, follow the procedure below:

1. Disable SPI (SPE = 0)
2. Clear the CRCEN bit
3. Set the CRCEN bit
4. Enable the SPI (SPE = 1)

### 24.3.7 Status flags

Three status flags are provided for the application to completely monitor the state of the SPI bus.

### Tx buffer empty flag (TXE)

When it is set, this flag indicates that the Tx buffer is empty and the next data to be transmitted can be loaded into the buffer. The TXE flag is cleared when writing to the SPI\_DR register.

### Rx buffer not empty (RXNE)

When set, this flag indicates that there are valid received data in the Rx buffer. It is cleared when SPI\_DR is read.

### BUSY flag

This BSY flag is set and cleared by hardware (writing to this flag has no effect). The BSY flag indicates the state of the communication layer of the SPI.

When BSY is set, it indicates that the SPI is busy communicating. There is one exception in master mode / bidirectional receive mode (MSTR=1 and BDM=1 and BDOE=0) where the BSY flag is kept low during reception.

The BSY flag is useful to detect the end of a transfer if the software wants to disable the SPI and enter Halt mode (or disable the peripheral clock). This avoids corrupting the last transfer. For this, the procedure described below must be strictly respected.

The BSY flag is also useful to avoid write collisions in a multimaster system.

The BSY flag is set when a transfer starts, with the exception of master mode / bidirectional receive mode (MSTR=1 and BDM=1 and BDOE=0).

It is cleared:

- when a transfer is finished (except in master mode if the communication is continuous)
- when the SPI is disabled
- when a master mode fault occurs (MODF=1)

When communication is not continuous, the BSY flag is low between each communication.

When communication is continuous:

- in master mode, the BSY flag is kept high during all the transfers
- in slave mode, the BSY flag goes low for one SPI clock cycle between each transfer

*Note: Do not use the BSY flag to handle each data transmission or reception. It is better to use the TXE and RXNE flags instead.*

## 24.3.8 Disabling the SPI

When a transfer is terminated, the application can stop the communication by disabling the SPI peripheral. This is done by clearing the SPE bit.

For some configurations, disabling the SPI and entering the Halt mode while a transfer is ongoing can cause the current transfer to be corrupted and/or the BSY flag might become unreliable.

To avoid any of those effects, it is recommended to respect the following procedure when disabling the SPI:

**In master or slave full-duplex mode (BIDIMODE=0, RXONLY=0)**

1. Wait until RXNE=1 to receive the last data
2. Wait until TXE=1
3. Then wait until BSY=0
4. Disable the SPI (SPE=0) and, eventually, enter the Halt mode (or disable the peripheral clock)

**In master or slave unidirectional transmit-only mode (BIDIMODE=0, RXONLY=0) or bidirectional transmit mode (BIDIMODE=1, BIDIOE=1)**

After the last data is written into the SPI\_DR register:

1. Wait until TXE=1
2. Then wait until BSY=0
3. Disable the SPI (SPE=0) and, eventually, enter the Halt mode (or disable the peripheral clock)

**In master unidirectional receive-only mode (MSTR=1, BIDIMODE=0, RXONLY=1) or bidirectional receive mode (MSTR=1, BIDIMODE=1, BIDIOE=0)**

This case must be managed in a particular way to ensure that the SPI does not initiate a new transfer:

1. Wait for the second to last occurrence of RXNE=1 (n-1)
2. Then wait for one SPI clock cycle (using a software loop) before disabling the SPI (SPE=0)
3. Then wait for the last RXNE=1 before entering the Halt mode (or disabling the peripheral clock)

*Note:* In master bidirectional receive mode (MSTR=1 and BDM=1 and BDOE=0), the BSY flag is kept low during transfers.

**In slave receive-only mode (MSTR=0, BIDIMODE=0, RXONLY=1) or bidirectional receive mode (MSTR=0, BIDIMODE=1, BIDIOE=0)**

1. You can disable the SPI (write SPE=0) at any time: the current transfer will complete before the SPI is effectively disabled
2. Then, if you want to enter the Halt mode, you must first wait until BSY = 0 before entering the Halt mode (or disabling the peripheral clock)

**24.3.9 SPI communication using DMA (direct memory addressing)**

To operate at its maximum speed, the SPI needs to be fed with the data for transmission and the data received on the Rx buffer should be read to avoid overrun. To facilitate the transfers, the SPI features a DMA capability implementing a simple request/acknowledge protocol.

A DMA access is requested when the enable bit in the SPI\_CR2 register is enabled. Separate requests must be issued to the Tx and Rx buffers (see [Figure 246](#) and [Figure 247](#)):

- In transmission, a DMA request is issued each time TXE is set to 1. The DMA then writes to the SPI\_DR register (this clears the TXE flag).
- In reception, a DMA request is issued each time RXNE is set to 1. The DMA then reads the SPI\_DR register (this clears the RXNE flag).



When the SPI is used only to transmit data, it is possible to enable only the SPI Tx DMA channel. In this case, the OVR flag is set because the data received are not read.

When the SPI is used only to receive data, it is possible to enable only the SPI Rx DMA channel.

In transmission mode, when the DMA has written all the data to be transmitted (flag TCIF is set in the DMA\_ISR register), the BSY flag can be monitored to ensure that the SPI communication is complete. This is required to avoid corrupting the last transmission before disabling the SPI or entering the Stop mode. The software must first wait until TXE=1 and then until BSY=0.

*Note: During discontinuous communications, there is a 2 APB clock period delay between the write operation to SPI\_DR and the BSY bit setting. As a consequence, it is mandatory to wait first until TXE=1 and then until BSY=0 after writing the last data.*

**Figure 246. Transmission using DMA**

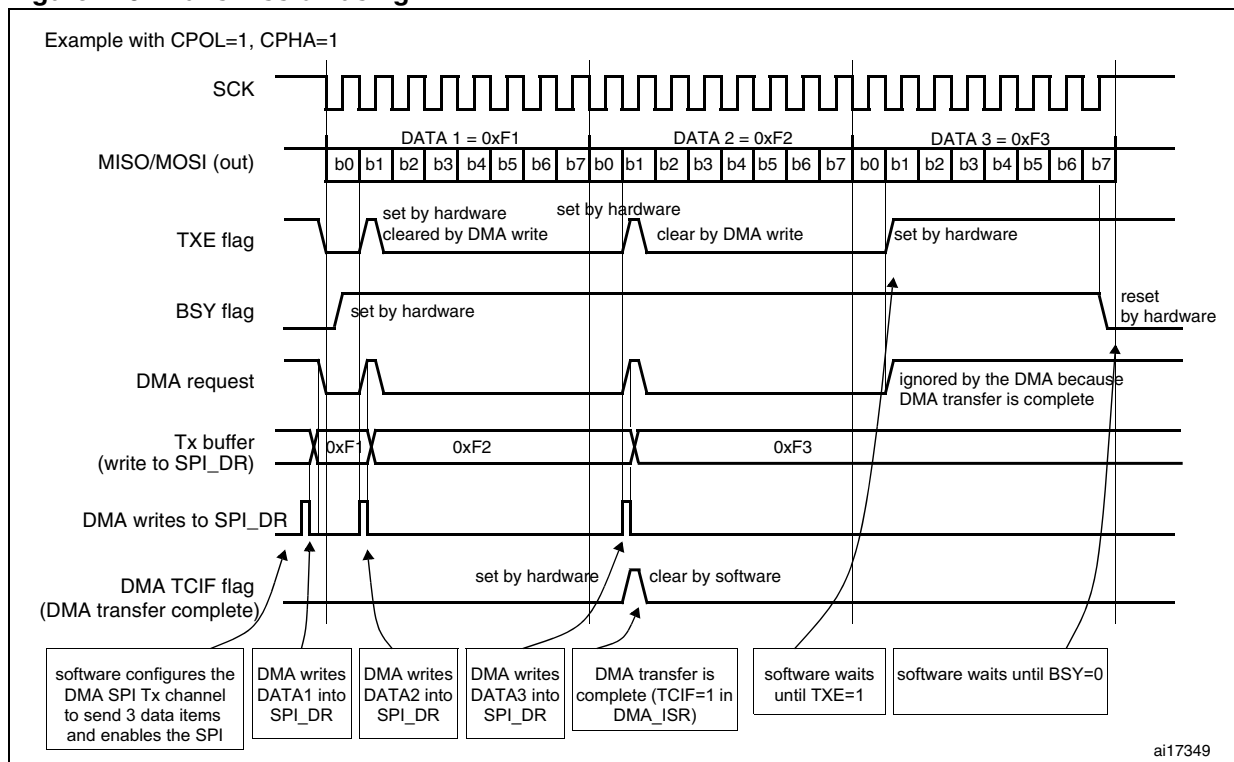
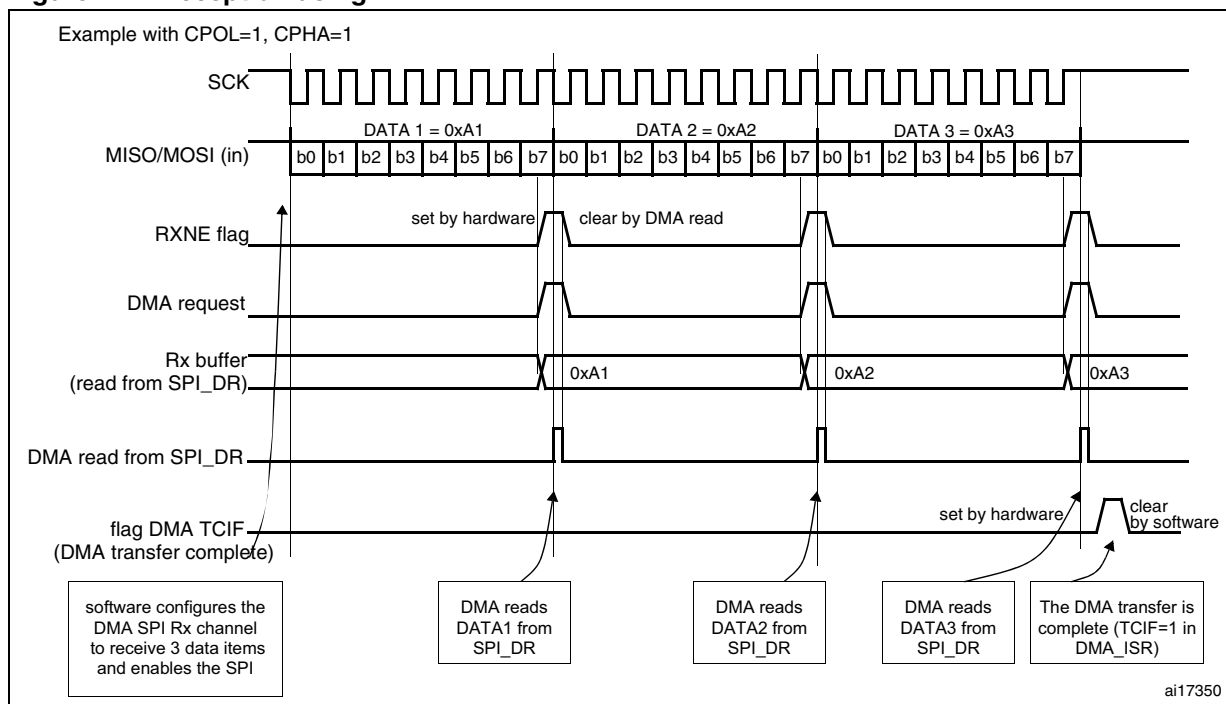


Figure 247. Reception using DMA



### DMA capability with CRC

When SPI communication is enabled with the CRC communication and the DMA mode, the transmission and reception of the CRC bytes at the end of communication are automatic.

At the end of data and CRC transfers, the CRCERR flag in SPI\_SR is set if corruption occurs during the transfer.

## 24.3.10 Error flags

### Master mode fault (MODF)

Master mode fault occurs when the master device has its NSS pin pulled low (in NSS hardware mode) or SSI bit low (in NSS software mode), this automatically sets the MODF bit. Master mode fault affects the SPI peripheral in the following ways:

- The MODF bit is set and an SPI interrupt is generated if the ERRIE bit is set.
- The SPE bit is cleared. This blocks all output from the device and disables the SPI interface.
- The MSTR bit is cleared, thus forcing the device into slave mode.

Use the following software sequence to clear the MODF bit:

1. Make a read or write access to the SPI\_SR register while the MODF bit is set.
2. Then write to the SPI\_CR1 register.

To avoid any multiple slave conflicts in a system comprising several MCUs, the NSS pin must be pulled high during the MODF bit clearing sequence. The SPE and MSTR bits can be restored to their original state after this clearing sequence.

As a security, hardware does not allow the setting of the SPE and MSTR bits while the MODF bit is set.

In a slave device the MODF bit cannot be set. However, in a multimaster configuration, the device can be in slave mode with this MODF bit set. In this case, the MODF bit indicates that there might have been a multimaster conflict for system control. An interrupt routine can be used to recover cleanly from this state by performing a reset or returning to a default state.

### Overrun condition

An overrun condition occurs when the master device has sent data bytes and the slave device has not cleared the RXNE bit resulting from the previous data byte transmitted.

When an overrun condition occurs:

- the OVR bit is set and an interrupt is generated if the ERRIE bit is set.

In this case, the receiver buffer contents will not be updated with the newly received data from the master device. A read from the SPI\_DR register returns this byte. All other subsequently transmitted bytes are lost.

Clearing the OVR bit is done by a read from the SPI\_DR register followed by a read access to the SPI\_SR register.

### CRC error

This flag is used to verify the validity of the value received when the CRCEN bit in the SPI\_CR1 register is set. The CRCERR flag in the SPI\_SR register is set if the value received in the shift register (after transmission of the transmitter SPI\_TXCRCR value) does not match the receiver SPI\_RXCRCR value.

## 24.3.11 SPI interrupts

**Table 179. SPI interrupt requests**

Interrupt event	Event flag	Enable Control bit
Transmit buffer empty flag	TXE	TXEIE
Receive buffer not empty flag	RXNE	RXNEIE
Master Mode fault event	MODF	ERRIE
Overrun error	OVR	
CRC error flag	CRCERR	

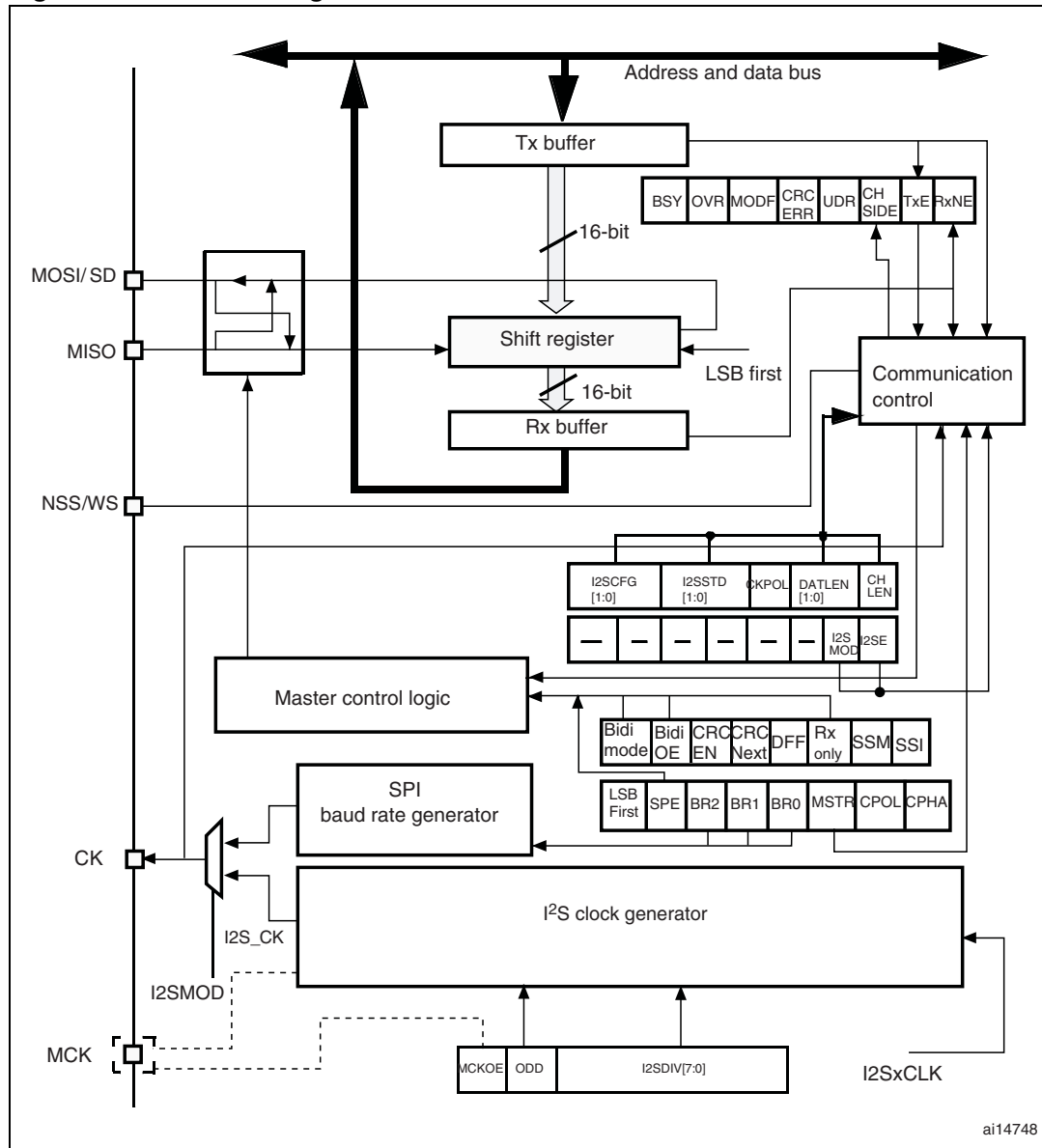
## 24.4 I<sup>2</sup>S functional description

The I<sup>2</sup>S audio protocol is not available in low- and medium-density devices. This section concerns only high-density, XL-density and connectivity line devices.

### 24.4.1 I<sup>2</sup>S general description

The block diagram of the I<sup>2</sup>S is shown in [Figure 248](#).

Figure 248. I<sup>2</sup>S block diagram



The SPI could function as an audio I<sup>2</sup>S interface when the I<sup>2</sup>S capability is enabled (by setting the I2SMOD bit in the SPI\_I2SCFGR register). This interface uses almost the same pins, flags and interrupts as the SPI.

The I<sup>2</sup>S shares three common pins with the SPI:

- SD: Serial Data (mapped on the MOSI pin) to transmit or receive the two time-multiplexed data channels (in simplex mode only).
- WS: Word Select (mapped on the NSS pin) is the data control signal output in master mode and input in slave mode.
- CK: Serial Clock (mapped on the SCK pin) is the serial clock output in master mode and serial clock input in slave mode.

An additional pin could be used when a master clock output is needed for some external audio devices:

- MCK: Master Clock (mapped separately) is used, when the I<sup>2</sup>S is configured in master mode (and when the MCKOE bit in the SPI\_I2SPR register is set), to output this additional clock generated at a preconfigured frequency rate equal to  $256 \times F_S$ , where  $F_S$  is the audio sampling frequency.

The I<sup>2</sup>S uses its own clock generator to produce the communication clock when it is set in master mode. This clock generator is also the source of the master clock output. Two additional registers are available in I<sup>2</sup>S mode. One is linked to the clock generator configuration SPI\_I2SPR and the other one is a generic I<sup>2</sup>S configuration register SPI\_I2SCFGR (audio standard, slave/master mode, data format, packet frame, clock polarity, etc.).

The SPI\_CR1 register and all CRC registers are not used in the I<sup>2</sup>S mode. Likewise, the SSOE bit in the SPI\_CR2 register and the MODF and CRCERR bits in the SPI\_SR are not used.

The I<sup>2</sup>S uses the same SPI register for data transfer (SPI\_DR) in 16-bit wide mode.

#### 24.4.2 Supported audio protocols

The three-line bus has to handle only audio data generally time-multiplexed on two channels: the right channel and the left channel. However there is only one 16-bit register for the transmission or the reception. So, it is up to the software to write into the data register the adequate value corresponding to the considered channel side, or to read the data from the data register and to identify the corresponding channel by checking the CHSIDE bit in the SPI\_SR register. Channel Left is always sent first followed by the channel right (CHSIDE has no meaning for the PCM protocol).

Four data and packet frames are available. Data may be sent with a format of:

- 16-bit data packed in 16-bit frame
- 16-bit data packed in 32-bit frame
- 24-bit data packed in 32-bit frame
- 32-bit data packed in 32-bit frame

When using 16-bit data extended on 32-bit packet, the first 16 bits (MSB) are the significant bits, the 16-bit LSB is forced to 0 without any need for software action or DMA request (only one read/write operation).

The 24-bit and 32-bit data frames need two CPU read or write operations to/from the SPI\_DR or two DMA operations if the DMA is preferred for the application. For 24-bit data frame specifically, the 8 non-significant bits are extended to 32 bits with 0-bits (by hardware).

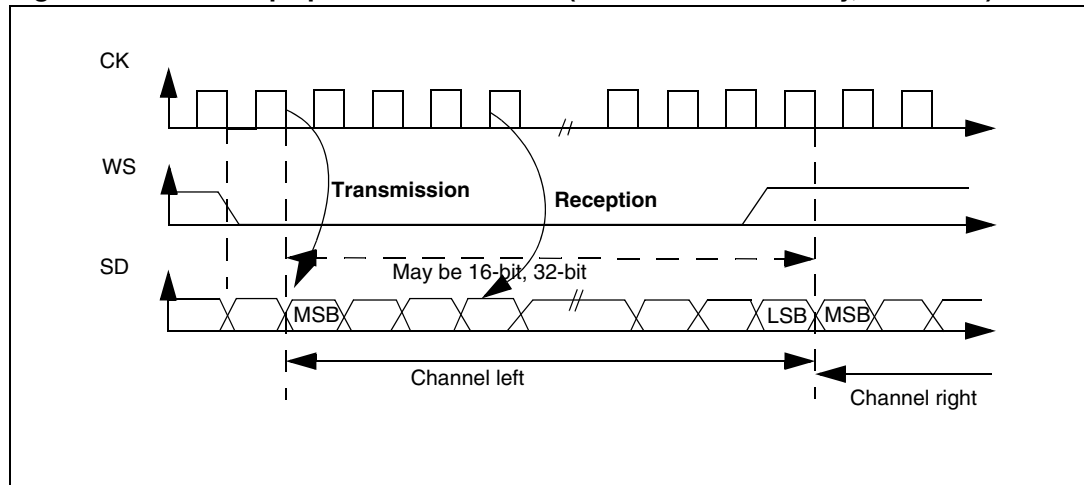
For all data formats and communication standards, the most significant bit is always sent first (MSB first).

The I<sup>2</sup>S interface supports four audio standards, configurable using the I2SSTD[1:0] and PCMSYNC bits in the SPI\_I2SCFGR register.

##### I<sup>2</sup>S Phillips standard

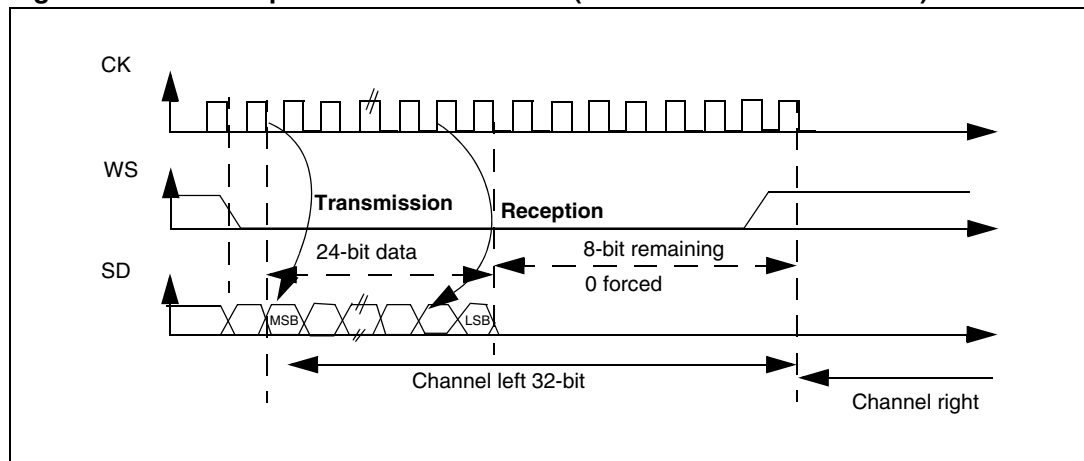
For this standard, the WS signal is used to indicate which channel is being transmitted. It is activated one CK clock cycle before the first bit (MSB) is available.

**Figure 249. I<sup>2</sup>S Phillips protocol waveforms (16/32-bit full accuracy, CPOL = 0)**



Data are latched on the falling edge of CK (for the transmitter) and are read on the rising edge (for the receiver). The WS signal is also latched on the falling edge of CK.

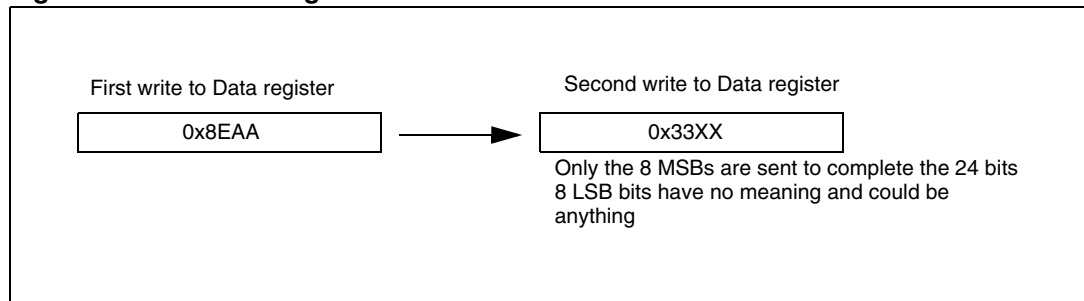
**Figure 250. I<sup>2</sup>S Phillips standard waveforms (24-bit frame with CPOL = 0)**



This mode needs two write or read operations to/from the SPI\_DR.

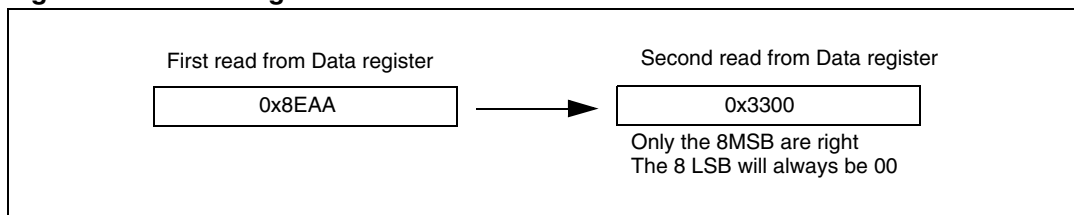
- In transmission mode:  
if 0x8EAA33 has to be sent (24-bit):

**Figure 251. Transmitting 0x8EAA33**

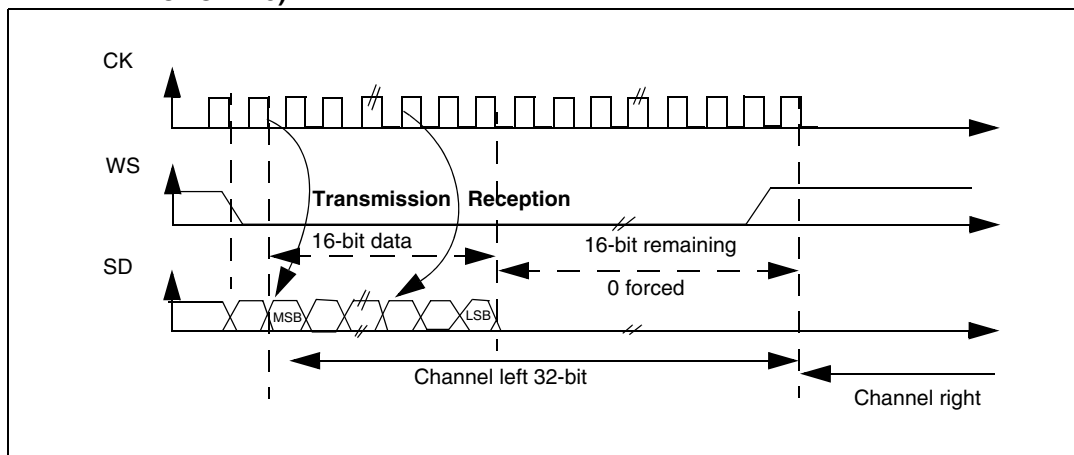


- In reception mode:  
if data 0x8EAA33 is received:

**Figure 252. Receiving 0x8EAA33**



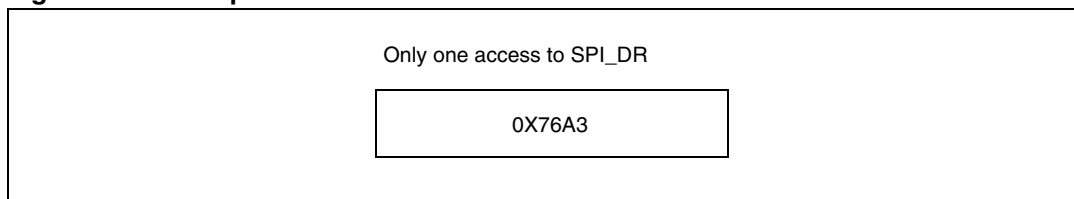
**Figure 253. I<sup>2</sup>S Phillips standard (16-bit extended to 32-bit packet frame with CPOL = 0)**



When 16-bit data frame extended to 32-bit channel frame is selected during the I<sup>2</sup>S configuration phase, only one access to SPI\_DR is required. The 16 remaining bits are forced by hardware to 0x0000 to extend the data to 32-bit format.

If the data to transmit or the received data are 0x76A3 (0x76A30000 extended to 32-bit), the operation shown in [Figure 254](#) is required.

**Figure 254. Example**



For transmission, each time an MSB is written to SPI\_DR, the TXE flag is set and its interrupt, if allowed, is generated to load SPI\_DR with the new value to send. This takes place even if 0x0000 have not yet been sent because it is done by hardware.

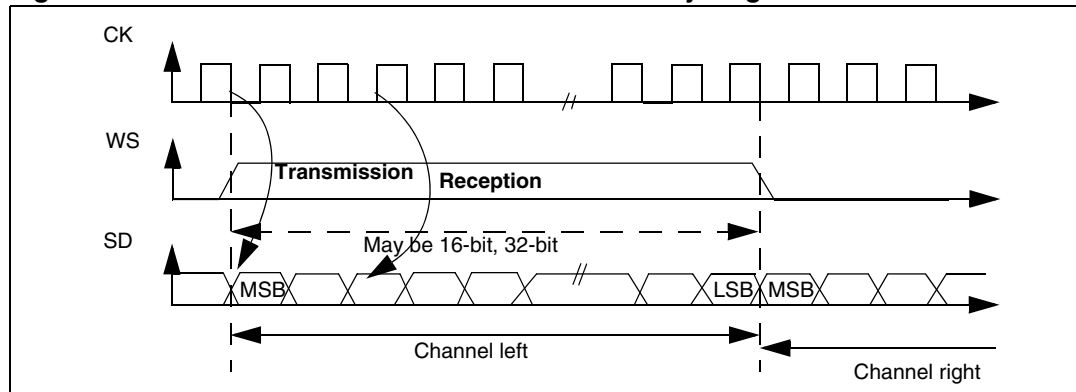
For reception, the RXNE flag is set and its interrupt, if allowed, is generated when the first 16 MSB half-word is received.

In this way, more time is provided between two write or read operations, which prevents underrun or overrun conditions (depending on the direction of the data transfer).

**MSB justified standard**

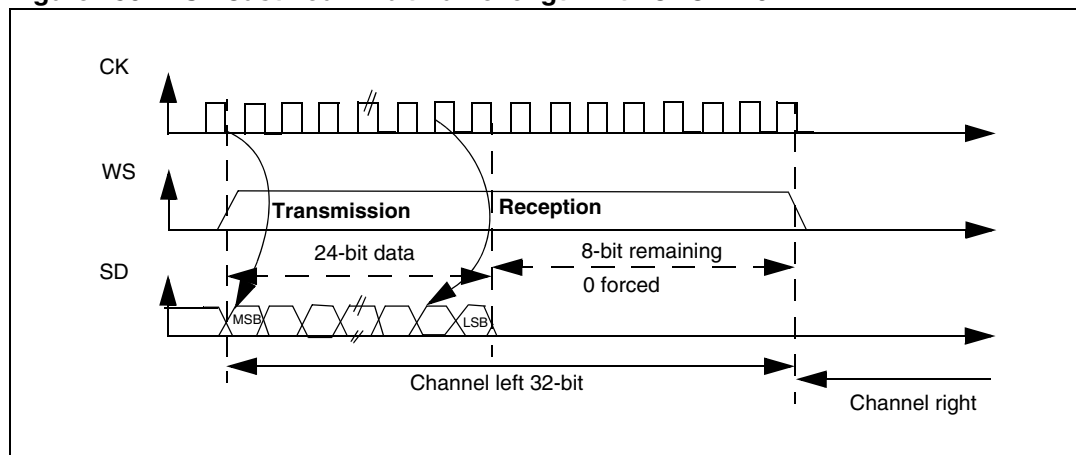
For this standard, the WS signal is generated at the same time as the first data bit, which is the MSBit.

**Figure 255. MSB Justified 16-bit or 32-bit full-accuracy length with CPOL = 0**

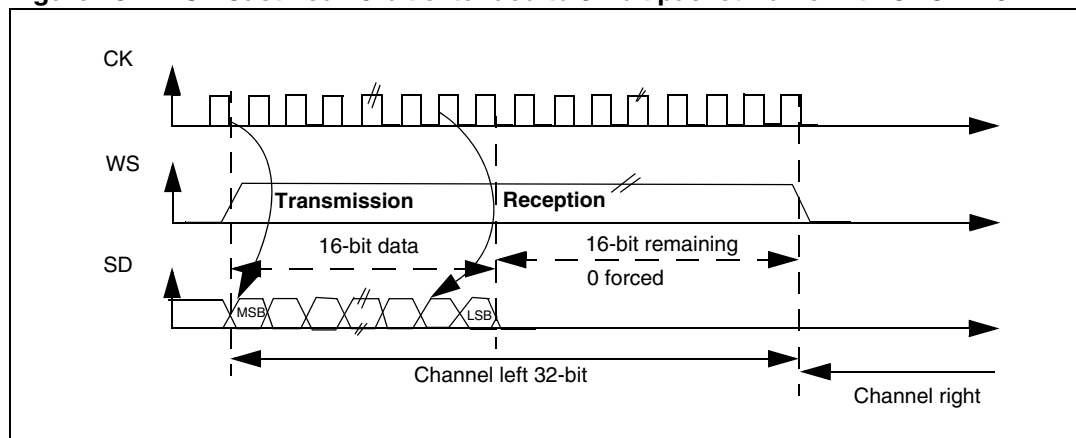


Data are latched on the falling edge of CK (for transmitter) and are read on the rising edge (for the receiver).

**Figure 256. MSB Justified 24-bit frame length with CPOL = 0**



**Figure 257. MSB Justified 16-bit extended to 32-bit packet frame with CPOL = 0**

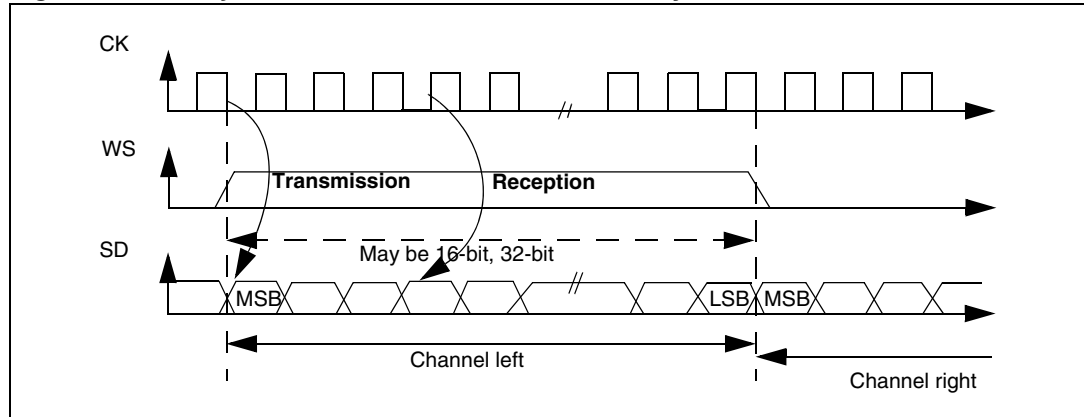




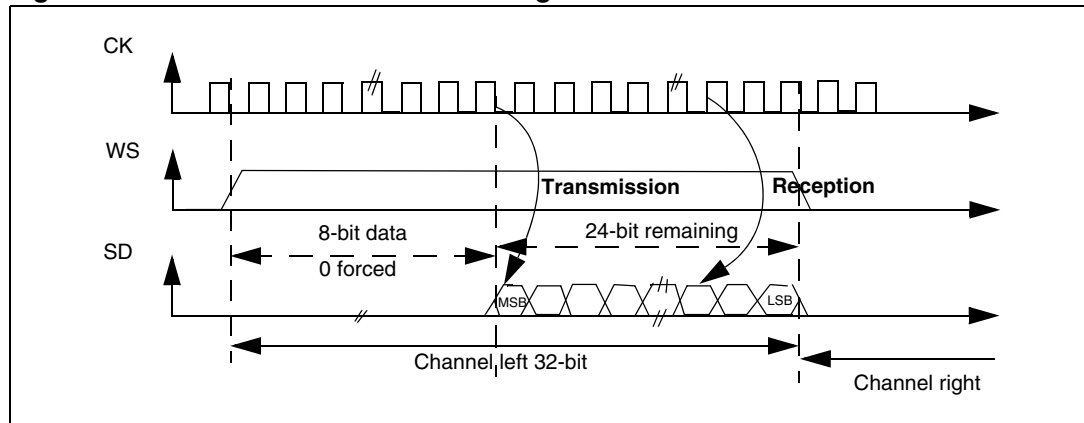
**LSB justified standard**

This standard is similar to the MSB justified standard (no difference for the 16-bit and 32-bit full-accuracy frame formats).

**Figure 258. LSB justified 16-bit or 32-bit full-accuracy with CPOL = 0**

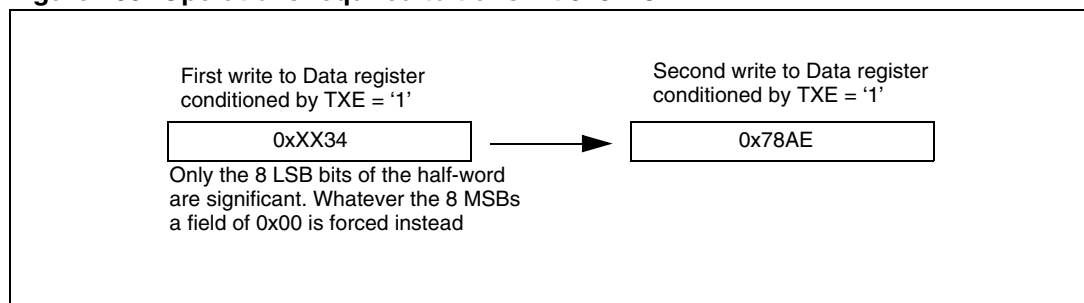


**Figure 259. LSB Justified 24-bit frame length with CPOL = 0**



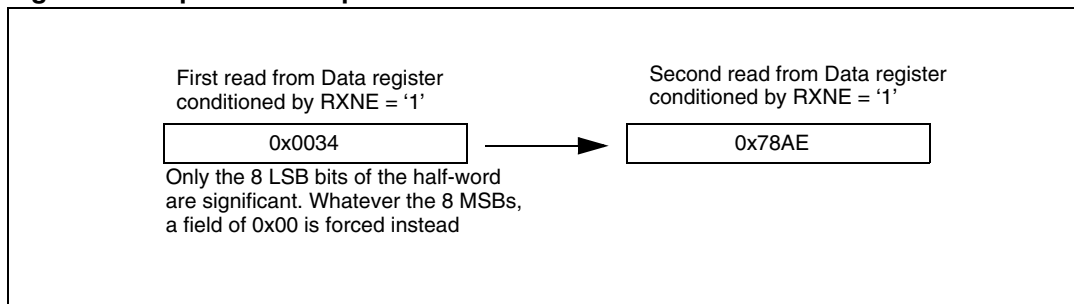
- In transmission mode:  
If data 0x3478AE have to be transmitted, two write operations to the SPI\_DR register are required from software or by DMA. The operations are shown below.

**Figure 260. Operations required to transmit 0x3478AE**

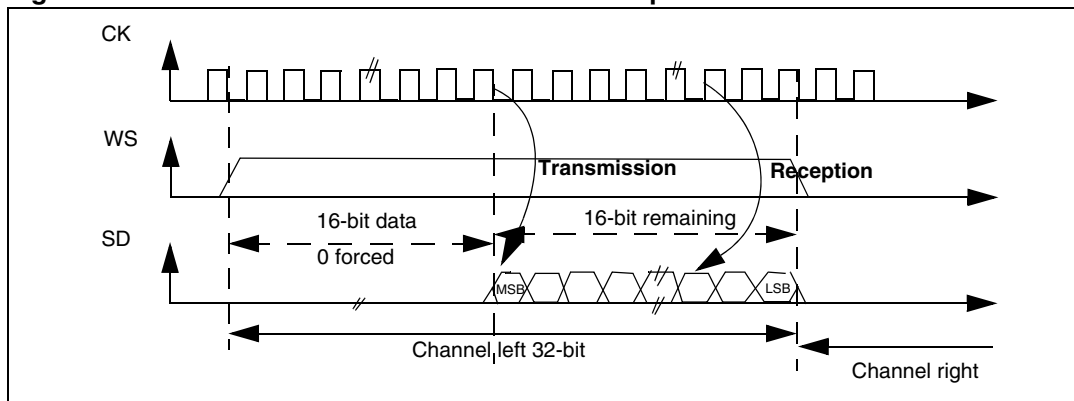


- In reception mode:  
If data 0x3478AE are received, two successive read operations from SPI\_DR are required on each RXNE event.

**Figure 261. Operations required to receive 0x3478AE**



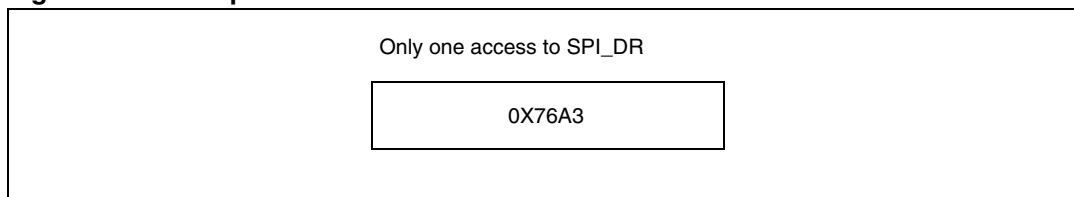
**Figure 262. LSB Justified 16-bit extended to 32-bit packet frame with CPOL = 0**



When 16-bit data frame extended to 32-bit channel frame is selected during the I<sup>2</sup>S configuration phase, Only one access to SPI\_DR is required. The 16 remaining bits are forced by hardware to 0x0000 to extend the data to 32-bit format. In this case it corresponds to the half-word MSB.

If the data to transmit or the received data are 0x76A3 (0x0000 76A3 extended to 32-bit), the operation shown in [Figure 263](#) is required.

**Figure 263. Example**



In transmission mode, when TXE is asserted, the application has to write the data to be transmitted (in this case 0x76A3). The 0x000 field is transmitted first (extension on 32-bit). TXE is asserted again as soon as the effective data (0x76A3) is sent on SD.

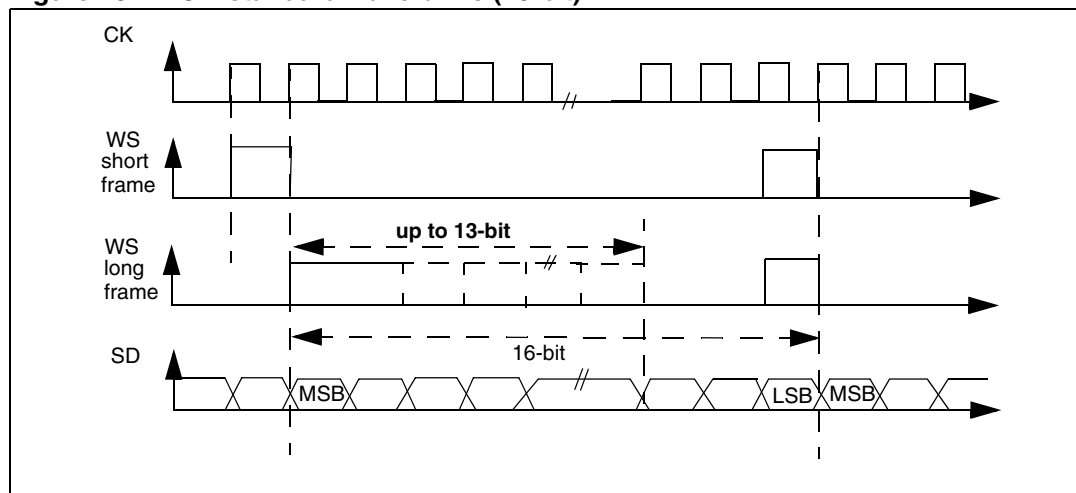
In reception mode, RXNE is asserted as soon as the significant half-word is received (and not the 0x0000 field).

In this way, more time is provided between two write or read operations to prevent underrun or overrun conditions.

**PCM standard**

For the PCM standard, there is no need to use channel-side information. The two PCM modes (short and long frame) are available and configurable using the PCMSYNC bit in SPI\_I2SCFGR.

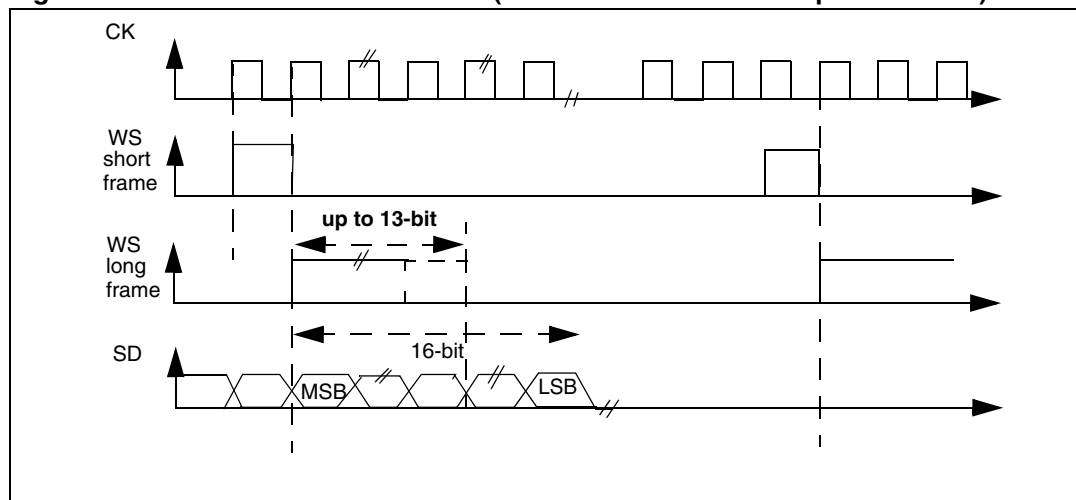
**Figure 264. PCM standard waveforms (16-bit)**



For long frame synchronization, the WS signal assertion time is fixed 13 bits in master mode.

For short frame synchronization, the WS synchronization signal is only one cycle long.

**Figure 265. PCM standard waveforms (16-bit extended to 32-bit packet frame)**



*Note:* For both modes (master and slave) and for both synchronizations (short and long), the number of bits between two consecutive pieces of data (and so two synchronization signals) needs to be specified (DATLEN and CHLEN bits in the SPI\_I2SCFGR register) even in slave mode.

### 24.4.3 Clock generator

The I<sup>2</sup>S bitrate determines the dataflow on the I<sup>2</sup>S data line and the I<sup>2</sup>S clock signal frequency.

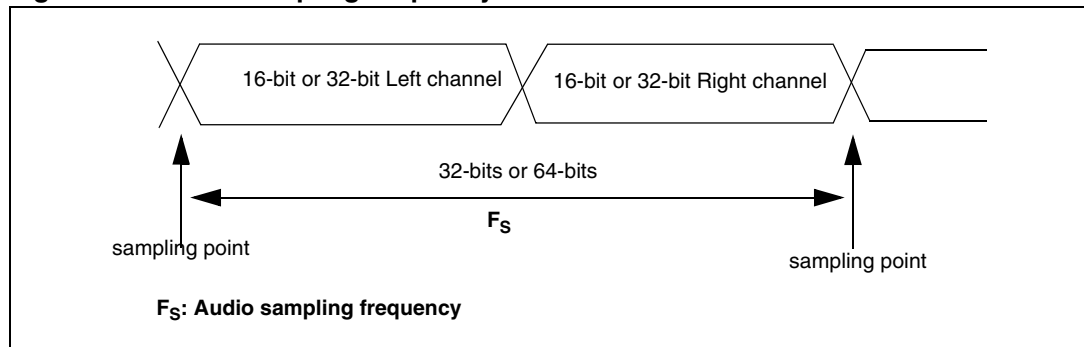
I<sup>2</sup>S bitrate = number of bits per channel × number of channels × sampling audio frequency

For a 16-bit audio, left and right channel, the I<sup>2</sup>S bitrate is calculated as follows:

$$I^2S \text{ bitrate} = 16 \times 2 \times F_S$$

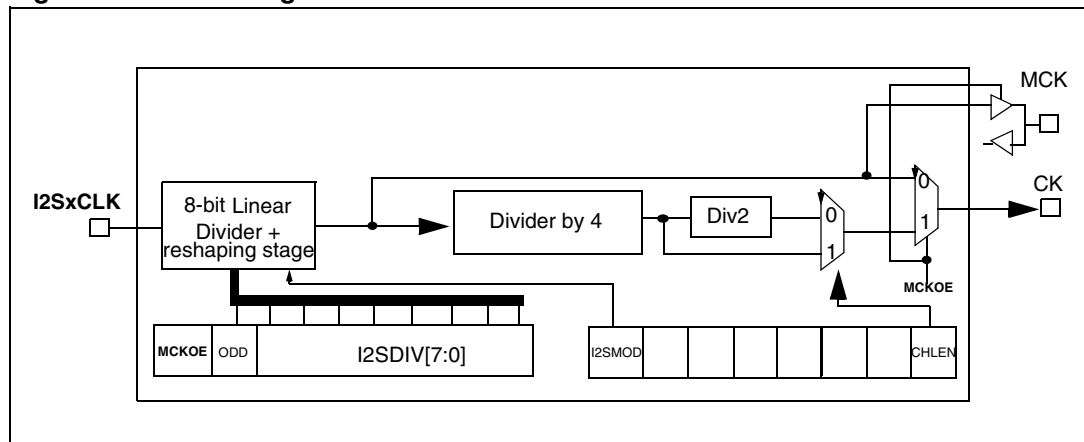
It will be: I<sup>2</sup>S bitrate = 32 × 2 × F<sub>S</sub> if the packet length is 32-bit wide.

**Figure 266. Audio sampling frequency definition**



When the master mode is configured, a specific action needs to be taken to properly program the linear divider in order to communicate with the desired audio frequency.

**Figure 267. I<sup>2</sup>S clock generator architecture**



1. Where x could be 2 or 3.

Figure 266 presents the communication clock architecture. the I2SxCLK source is the system clock (provided by the HSI, the HSE or the PLL and sourcing the AHB clock). For connectivity line devices, the I2SxCLK source can be either SYSCLK or the PLL3 VCO (2 × PLL3CLK) clock in order to have maximum accuracy. This selection is made using the I2S2SRC and I2S3SRC bits in the RCC\_CFGR2 register.

The audio sampling frequency may be 96 kHz, 48 kHz, 44.1 kHz, 32 kHz, 22.05 kHz, 16 kHz, 11.025 kHz or 8 kHz (or any other value within this range). In order to reach the desired frequency, the linear divider needs to be programmed according to the formulas below:

When the master clock is generated (MCKOE in the SPI\_I2SPR register is set):

$$F_S = I2SxCLK / [(16 \cdot 2)^{((2 \cdot I2SDIV) + ODD) \cdot 8}] \text{ when the channel frame is 16-bit wide}$$

$$F_S = I2SxCLK / [(32 \cdot 2)^{((2 \cdot I2SDIV) + ODD) \cdot 4}] \text{ when the channel frame is 32-bit wide}$$

When the master clock is disabled (MCKOE bit cleared):

$$F_S = I2SxCLK / [(16 \cdot 2)^{((2 \cdot I2SDIV) + ODD)}] \text{ when the channel frame is 16-bit wide}$$

$$F_S = I2SxCLK / [(32 \cdot 2)^{((2 \cdot I2SDIV) + ODD)}] \text{ when the channel frame is 32-bit wide}$$

Table 181 and Table 182 provide example precision values for different clock configurations.

Note: Other configurations are possible that allow optimum clock precision.

**Table 180. Audio-frequency precision using standard 8 MHz HSE (high-density and XL-density devices only)**

SYSCLK (MHz)	I2S_DIV		I2S_ODD		MCLK	Target f <sub>S</sub> (Hz)	Real f <sub>S</sub> (KHz)		Error	
	16-bit	32-bit	16-bit	32-bit			16-bit	32-bit	16-bit	32-bit
72	11	6	1	0	No	96000	97826.09	93750	1.90%	2.34%
72	23	11	1	1	No	48000	47872.34	48913.04	0.27%	1.90%
72	25	13	1	0	No	44100	44117.65	43269.23	0.04%	1.88%
72	35	17	0	1	No	32000	32142.86	32142.86	0.44%	0.44%
72	51	25	0	1	No	22050	22058.82	22058.82	0.04%	0.04%
72	70	35	1	0	No	16000	15675.75	16071.43	0.27%	0.45%
72	102	51	0	0	No	11025	11029.41	11029.41	0.04%	0.04%
72	140	70	1	1	No	8000	8007.11	7978.72	0.09%	0.27%
72	2	2	0	0	Yes	96000	70312.15	70312.15	26.76%	26.76%
72	3	3	0	0	Yes	48000	46875	46875	2.34%	2.34%
72	3	3	0	0	Yes	44100	46875	46875	6.29%	6.29%
72	9	9	0	0	Yes	32000	31250	31250	2.34%	2.34%
72	6	6	1	1	Yes	22050	21634.61	21634.61	1.88%	1.88%
72	9	9	0	0	Yes	16000	15625	15625	2.34%	2.34%
72	13	13	0	0	Yes	11025	10817.30	10817.30	1.88%	1.88%
72	17	17	1	1	Yes	8000	8035.71	8035.71	0.45%	0.45%

**Table 181. Audio-frequency precision using standard 25 MHz and PLL3 (connectivity line devices only)**

PREDIV2		PLL3MUL		I2SDIV		I2SODD		MCLK	Target f <sub>s</sub> (Hz)	Real f <sub>s</sub> (kHz)		Error	
16-bit	32-bit	16-bit	32-bit	16-bit	32-bit	16-bit	32-bit			16-bit	32-bit	16-bit	32-bit
6	6	14	14	19	9	0	1	No	96000	95942.98	95942.98	0.0594%	0.0594%
7	12	20	14	46	9	1	1	No	48000	48003.07	47971.49	0.0064%	0.0594%
8	8	14	14	31	15	0	1	No	44100	44102.82	44102.82	0.0064%	0.0064%
11	4	16	10	35	30	1	1	No	32000	32010.24	32018.44	0.0320%	0.0576%
8	8	14	14	62	31	0	0	No	22050	22051.41	22051.41	0.0064%	0.0064%
7	11	20	16	139	35	1	1	No	16000	16001.02	16005.12	0.0064%	0.0320%
8	8	14	14	124	62	0	0	No	11025	11025.71	11025.71	0.0064%	0.0064%
9	9	20	20	217	108	0	1	No	8000	8000.512	8000.512	0.0064%	0.0064%
4	4	8	8	2	2	0	0	Yes	96000	97656.25	97656.25	1.7253%	1.7253%
13	13	16	16	2	2	1	1	Yes	48000	48076.92	48076.92	0.1603%	0.1603%
5	5	9	9	4	4	0	0	Yes	44100	43945.31	43945.31	0.3508%	0.3508%
5	5	9	9	5	5	1	1	Yes	32000	31960.22	31960.22	0.1243%	0.1243%
5	5	13	13	11	11	1	1	Yes	22050	22078.80	22078.80	0.1306%	0.1306%
9	9	14	14	9	9	1	1	Yes	16000	15990.49	15990.49	0.0594%	0.0594%
8	8	14	14	15	15	1	1	Yes	11025	11025.70	11025.70	0.0064%	0.0064%
4	4	10	10	30	30	1	1	Yes	8000	8004.611	8004.611	0.0576%	0.0576%

**Table 182. Audio-frequency precision using standard 14.7456 MHz and PLL3 (connectivity line devices only)**

PREDIV2		PLL3MUL		I2SDIV		I2SODD		MCLK	Target f <sub>s</sub> (Hz)	Real f <sub>s</sub> (kHz)		Error	
16-bit	32-bit	16-bit	32-bit	16-bit	32-bit	16-bit	32-bit			16-bit	32-bit	16-bit	32-bit
3	3	10	10	16	8	0	0	No	96000	96000	96000	0%	0%
6	6	20	20	32	16	0	0	No	48000	48000	48000	0%	0%
11	11	20	20	19	9	0	1	No	44100	44095.69	44095.69	0.0098%	0.0098%
2	2	10	10	72	36	0	0	No	32000	32000	32000	0%	0%
11	11	10	10	19	9	0	1	No	22050	22047.84	22047.84	0.0098%	0.0098%
4	4	20	20	144	72	0	0	No	16000	16000	16000	0%	0%
2	2	10	10	209	104	0	1	No	11025	11023.92	11023.92	0.0098%	0.0098%
12	12	20	20	96	48	0	0	No	8000	8000	8000	0%	0%
2	2	10	10	3	3	0	0	Yes	96000	96000	96000	0%	0%
6	6	20	20	4	4	0	0	Yes	48000	48000	48000	0%	0%
2	2	10	10	6	6	1	1	Yes	44100	44307.69	44307.69	0.4710%	0.4710%
2	2	10	10	9	9	0	0	Yes	32000	32000	32000	0%	0%

**Table 182. Audio-frequency precision using standard 14.7456 MHz and PLL3 (connectivity line devices only) (continued)**

PREDIV2		PLL3MUL		I2SDIV		I2SODD		MCLK	Target f <sub>s</sub> (Hz)	Real f <sub>s</sub> (kHz)		Error	
16-bit	32-bit	16-bit	32-bit	16-bit	32-bit	16-bit	32-bit			16-bit	32-bit	16-bit	32-bit
4	4	13	13	8	8	1	1	Yes	22050	22023.52	22023.52	0.1200%	0.1200%
4	4	20	20	18	18	0	0	Yes	16000	16000	16000	0%	0%
11	11	20	20	9	9	1	1	Yes	11025	11023.92	11023.92	0.0098%	0.0098%
6	6	20	20	24	24	0	0	Yes	8000	8000	8000	0%	0%

#### 24.4.4 I<sup>2</sup>S master mode

The I<sup>2</sup>S can be configured in master mode. This means that the serial clock is generated on the CK pin as well as the Word Select signal WS. Master clock (MCK) may be output or not, thanks to the MCKOE bit in the SPI\_I2SPR register.

##### Procedure

1. Select the I2SDIV[7:0] bits in the SPI\_I2SPR register to define the serial clock baud rate to reach the proper audio sample frequency. The ODD bit in the SPI\_I2SPR register also has to be defined.
2. Select the CKPOL bit to define the steady level for the communication clock. Set the MCKOE bit in the SPI\_I2SPR register if the master clock MCK needs to be provided to the external DAC/ADC audio component (the I2SDIV and ODD values should be computed depending on the state of the MCK output, for more details refer to [Section 24.4.3: Clock generator](#)).
3. Set the I2SMOD bit in SPI\_I2SCFGR to activate the I<sup>2</sup>S functionalities and choose the I<sup>2</sup>S standard through the I2SSTD[1:0] and PCMSYNC bits, the data length through the DATLEN[1:0] bits and the number of bits per channel by configuring the CHLEN bit. Select also the I<sup>2</sup>S master mode and direction (Transmitter or Receiver) through the I2SCFG[1:0] bits in the SPI\_I2SCFGR register.
4. If needed, select all the potential interruption sources and the DMA capabilities by writing the SPI\_CR2 register.
5. The I2SE bit in SPI\_I2SCFGR register must be set.

WS and CK are configured in output mode. MCK is also an output, if the MCKOE bit in SPI\_I2SPR is set.

##### Transmission sequence

The transmission sequence begins when a half-word is written into the Tx buffer.

Assumedly, the first data written into the Tx buffer correspond to the channel Left data. When data are transferred from the Tx buffer to the shift register, TXE is set and data corresponding to the channel Right have to be written into the Tx buffer. The CHSIDE flag indicates which channel is to be transmitted. It has a meaning when the TXE flag is set because the CHSIDE flag is updated when TXE goes high.

A full frame has to be considered as a Left channel data transmission followed by a Right channel data transmission. It is not possible to have a partial frame where only the left channel is sent.

The data half-word is parallel loaded into the 16-bit shift register during the first bit transmission, and then shifted out, serially, to the MOSI/SD pin, MSB first. The TXE flag is set after each transfer from the Tx buffer to the shift register and an interrupt is generated if the TXEIE bit in the SPI\_CR2 register is set.

For more details about the write operations depending on the I<sup>2</sup>S standard mode selected, refer to [Section 24.4.2: Supported audio protocols](#).

To ensure a continuous audio data transmission, it is mandatory to write the SPI\_DR with the next data to transmit before the end of the current transmission.

To switch off the I<sup>2</sup>S, by clearing I2SE, it is mandatory to wait for TXE = 1 and BSY = 0.

### Reception sequence

The operating mode is the same as for the transmission mode except for the point 3 (refer to the procedure described in [Section 24.4.4: I2S master mode](#)), where the configuration should set the master reception mode through the I2SCFG[1:0] bits.

Whatever the data or channel length, the audio data are received by 16-bit packets. This means that each time the Rx buffer is full, the RXNE flag is set and an interrupt is generated if the RXNEIE bit is set in SPI\_CR2 register. Depending on the data and channel length configuration, the audio value received for a right or left channel may result from one or two receptions into the Rx buffer.

Clearing the RXNE bit is performed by reading the SPI\_DR register.

CHSIDE is updated after each reception. It is sensitive to the WS signal generated by the I<sup>2</sup>S cell.

For more details about the read operations depending on the I<sup>2</sup>S standard mode selected, refer to [Section 24.4.2: Supported audio protocols](#).

If data are received while the previously received data have not been read yet, an overrun is generated and the OVR flag is set. If the ERRIE bit is set in the SPI\_CR2 register, an interrupt is generated to indicate the error.

To switch off the I<sup>2</sup>S, specific actions are required to ensure that the I<sup>2</sup>S completes the transfer cycle properly without initiating a new data transfer. The sequence depends on the



configuration of the data and channel lengths, and on the audio protocol mode selected. In the case of:

- 16-bit data length extended on 32-bit channel length (DATLEN = 00 and CHLEN = 1) using the LSB justified mode (I2SSTD = 10)
  - a) Wait for the second to last RXNE = 1 ( $n - 1$ )
  - b) Then wait 17 I<sup>2</sup>S clock cycles (using a software loop)
  - c) Disable the I<sup>2</sup>S (I2SE = 0)
- 16-bit data length extended on 32-bit channel length (DATLEN = 00 and CHLEN = 1) in MSB justified, I<sup>2</sup>S or PCM modes (I2SSTD = 00, I2SSTD = 01 or I2SSTD = 11, respectively)
  - a) Wait for the last RXNE
  - b) Then wait 1 I<sup>2</sup>S clock cycle (using a software loop)
  - c) Disable the I<sup>2</sup>S (I2SE = 0)
- For all other combinations of DATLEN and CHLEN, whatever the audio mode selected through the I2SSTD bits, carry out the following sequence to switch off the I<sup>2</sup>S:
  - a) Wait for the second to last RXNE = 1 ( $n - 1$ )
  - b) Then wait one I<sup>2</sup>S clock cycle (using a software loop)
  - c) Disable the I<sup>2</sup>S (I2SE = 0)

*Note:* The BSY flag is kept low during transfers.

#### 24.4.5 I<sup>2</sup>S slave mode

For the slave configuration, the I<sup>2</sup>S can be configured in transmission or reception mode. The operating mode is following mainly the same rules as described for the I<sup>2</sup>S master configuration. In slave mode, there is no clock to be generated by the I<sup>2</sup>S interface. The clock and WS signals are input from the external master connected to the I<sup>2</sup>S interface. There is then no need, for the user, to configure the clock.

The configuration steps to follow are listed below:

1. Set the I2SMOD bit in the SPI\_I2SCFGR register to reach the I<sup>2</sup>S functionalities and choose the I<sup>2</sup>S standard through the I2SSTD[1:0] bits, the data length through the DATLEN[1:0] bits and the number of bits per channel for the frame configuring the CHLEN bit. Select also the mode (transmission or reception) for the slave through the I2SCFG[1:0] bits in SPI\_I2SCFGR register.
2. If needed, select all the potential interrupt sources and the DMA capabilities by writing the SPI\_CR2 register.
3. The I2SE bit in SPI\_I2SCFGR register must be set.

#### Transmission sequence

The transmission sequence begins when the external master device sends the clock and when the NSS\_WS signal requests the transfer of data. The slave has to be enabled before the external master starts the communication. The I<sup>2</sup>S data register has to be loaded before the master initiates the communication.

For the I<sup>2</sup>S, MSB justified and LSB justified modes, the first data item to be written into the data register corresponds to the data for the left channel. When the communication starts, the data are transferred from the Tx buffer to the shift register. The TXE flag is then set in order to request the right channel data to be written into the I<sup>2</sup>S data register.

The CHSIDE flag indicates which channel is to be transmitted. Compared to the master transmission mode, in slave mode, CHSIDE is sensitive to the WS signal coming from the external master. This means that the slave needs to be ready to transmit the first data before the clock is generated by the master. WS assertion corresponds to left channel transmitted first.

*Note:* The I2SE has to be written at least two PCLK cycles before the first clock of the master comes on the CK line.

The data half-word is parallel-loaded into the 16-bit shift register (from the internal bus) during the first bit transmission, and then shifted out serially to the MOSI/SD pin MSB first. The TXE flag is set after each transfer from the Tx buffer to the shift register and an interrupt is generated if the TXEIE bit in the SPI\_CR2 register is set.

Note that the TXE flag should be checked to be at 1 before attempting to write the Tx buffer.

For more details about the write operations depending on the I<sup>2</sup>S standard mode selected, refer to [Section 24.4.2: Supported audio protocols](#).

To secure a continuous audio data transmission, it is mandatory to write the SPI\_DR register with the next data to transmit before the end of the current transmission. An underrun flag is set and an interrupt may be generated if the data are not written into the SPI\_DR register before the first clock edge of the next data communication. This indicates to the software that the transferred data are wrong. If the ERRIE bit is set into the SPI\_CR2 register, an interrupt is generated when the UDR flag in the SPI\_SR register goes high. In this case, it is mandatory to switch off the I<sup>2</sup>S and to restart a data transfer starting from the left channel.

To switch off the I<sup>2</sup>S, by clearing the I2SE bit, it is mandatory to wait for TXE = 1 and BSY = 0.

### Reception sequence

The operating mode is the same as for the transmission mode except for the point 1 (refer to the procedure described in [Section 24.4.5: I2S slave mode](#)), where the configuration should set the master reception mode using the I2SCFG[1:0] bits in the SPI\_I2SCFGR register.

Whatever the data length or the channel length, the audio data are received by 16-bit packets. This means that each time the RX buffer is full, the RXNE flag in the SPI\_SR register is set and an interrupt is generated if the RXNEIE bit is set in the SPI\_CR2 register. Depending on the data length and channel length configuration, the audio value received for a right or left channel may result from one or two receptions into the RX buffer.

The CHSIDE flag is updated each time data are received to be read from SPI\_DR. It is sensitive to the external WS line managed by the external master component.

Clearing the RXNE bit is performed by reading the SPI\_DR register.

For more details about the read operations depending on the I<sup>2</sup>S standard mode selected, refer to [Section 24.4.2: Supported audio protocols](#).

If data are received while the precedent received data have not yet been read, an overrun is generated and the OVR flag is set. If the bit ERRIE is set in the SPI\_CR2 register, an interrupt is generated to indicate the error.

To switch off the I<sup>2</sup>S in reception mode, I2SE has to be cleared immediately after receiving the last RXNE = 1.

*Note:* The external master components should have the capability of sending/receiving data in 16-bit or 32-bit packets via an audio channel.

## 24.4.6 Status flags

Three status flags are provided for the application to fully monitor the state of the I<sup>2</sup>S bus.

### Busy flag (BSY)

The BSY flag is set and cleared by hardware (writing to this flag has no effect). It indicates the state of the communication layer of the I<sup>2</sup>S.

When BSY is set, it indicates that the I<sup>2</sup>S is busy communicating. There is one exception in master receive mode (I2SCFG = 11) where the BSY flag is kept low during reception.

The BSY flag is useful to detect the end of a transfer if the software needs to disable the I<sup>2</sup>S. This avoids corrupting the last transfer. For this, the procedure described below must be strictly respected.

The BSY flag is set when a transfer starts, except when the I<sup>2</sup>S is in master receiver mode.

The BSY flag is cleared:

- when a transfer completes (except in master transmit mode, in which the communication is supposed to be continuous)
- when the I<sup>2</sup>S is disabled

When communication is continuous:

- In master transmit mode, the BSY flag is kept high during all the transfers
- In slave mode, the BSY flag goes low for one I<sup>2</sup>S clock cycle between each transfer

*Note:* Do not use the BSY flag to handle each data transmission or reception. It is better to use the TXE and RXNE flags instead.

### Tx buffer empty flag (TXE)

When set, this flag indicates that the Tx buffer is empty and the next data to be transmitted can then be loaded into it. The TXE flag is reset when the Tx buffer already contains data to be transmitted. It is also reset when the I<sup>2</sup>S is disabled (I2SE bit is reset).

### RX buffer not empty (RXNE)

When set, this flag indicates that there are valid received data in the RX Buffer. It is reset when SPI\_DR register is read.

### Channel Side flag (CHSIDE)

In transmission mode, this flag is refreshed when TXE goes high. It indicates the channel side to which the data to transfer on SD has to belong. In case of an underrun error event in slave transmission mode, this flag is not reliable and I<sup>2</sup>S needs to be switched off and switched on before resuming the communication.

In reception mode, this flag is refreshed when data are received into SPI\_DR. It indicates from which channel side data have been received. Note that in case of error (like OVR) this flag becomes meaningless and the I<sup>2</sup>S should be reset by disabling and then enabling it (with configuration if it needs changing).

This flag has no meaning in the PCM standard (for both Short and Long frame modes).

When the OVR or UDR flag in the SPI\_SR is set and the ERRIE bit in SPI\_CR2 is also set, an interrupt is generated. This interrupt can be cleared by reading the SPI\_SR status register (once the interrupt source has been cleared).

### 24.4.7 Error flags

There are two error flags for the I<sup>2</sup>S cell.

#### Underrun flag (UDR)

In slave transmission mode this flag is set when the first clock for data transmission appears while the software has not yet loaded any value into SPI\_DR. It is available when the I2SMOD bit in SPI\_I2SCFGR is set. An interrupt may be generated if the ERRIE bit in SPI\_CR2 is set.

The UDR bit is cleared by a read operation on the SPI\_SR register.

#### Overrun flag (OVR)

This flag is set when data are received and the previous data have not yet been read from SPI\_DR. As a result, the incoming data are lost. An interrupt may be generated if the ERRIE bit is set in SPI\_CR2.

In this case, the receive buffer contents are not updated with the newly received data from the transmitter device. A read operation to the SPI\_DR register returns the previous correctly received data. All other subsequently transmitted half-words are lost.

Clearing the OVR bit is done by a read operation on the SPI\_DR register followed by a read access to the SPI\_SR register.

### 24.4.8 I<sup>2</sup>S interrupts

[Table 183](#) provides the list of I<sup>2</sup>S interrupts.

**Table 183. I<sup>2</sup>S interrupt requests**

Interrupt event	Event flag	Enable Control bit
Transmit buffer empty flag	TXE	TXEIE
Receive buffer not empty flag	RXNE	RXNEIE
Overrun error	OVR	ERRIE
Underrun error	UDR	

### 24.4.9 DMA features

DMA is working in exactly the same way as for the SPI mode. There is no difference on the I<sup>2</sup>S. Only the CRC feature is not available in I<sup>2</sup>S mode since there is no data transfer protection system.

## 24.5 SPI and I<sup>2</sup>S registers

Refer to [Section 1.1 on page 40](#) for a list of abbreviations used in register descriptions.

The peripheral registers can be accessed by half-words (16-bit) or words (32-bit).

### 24.5.1 SPI control register 1 (SPI\_CR1) (not used in I<sup>2</sup>S mode)

Address offset: 0x00

Reset value: 0x0000

15	14	13	12	11	10	9	8	7	6	5	4	3	2	1	0
BIDI MODE	BIDI OE	CRC EN	CRC NEXT	DFF	RX ONLY	SSM	SSI	LSB FIRST	SPE	BR [2:0]			MSTR	CPOL	CPHA
rw	rw	rw	rw	rw	rw	rw	rw	rw	rw	rw	rw	rw	rw	rw	rw

Bit 15 **BIDIMODE**: Bidirectional data mode enable

0: 2-line unidirectional data mode selected

1: 1-line bidirectional data mode selected

*Note: Not used in I<sup>2</sup>S mode*

Bit 14 **BIDIOE**: Output enable in bidirectional mode

This bit combined with the BIDImode bit selects the direction of transfer in bidirectional mode

0: Output disabled (receive-only mode)

1: Output enabled (transmit-only mode)

*Note: In master mode, the MOSI pin is used and in slave mode, the MISO pin is used.*

*Not used in I<sup>2</sup>S mode*

Bit 13 **CRCEN**: Hardware CRC calculation enable

0: CRC calculation disabled

1: CRC calculation Enabled

*Note: This bit should be written only when SPI is disabled (SPE = '0') for correct operation*

*Not used in I<sup>2</sup>S mode*

Bit 12 **CRCNEXT**: Transmit CRC next

0: Next transmit value is from Tx buffer

1: Next transmit value is from Tx CRC register

*Note: This bit has to be written as soon as the last data is written into the SPI\_DR register.*

*Not used in I<sup>2</sup>S mode*

Bit 11 **DFF**: Data frame format

0: 8-bit data frame format is selected for transmission/reception

1: 16-bit data frame format is selected for transmission/reception

*Note: This bit should be written only when SPI is disabled (SPE = '0') for correct operation*

*Not used in I<sup>2</sup>S mode*

Bit 10 **RXONLY**: Receive only

This bit combined with the BIDImode bit selects the direction of transfer in 2-line unidirectional mode. This bit is also useful in a multislave system in which this particular slave is not accessed, the output from the accessed slave is not corrupted.

0: Full duplex (Transmit and receive)

1: Output disabled (Receive-only mode)

*Note: Not used in I<sup>2</sup>S mode*

Bit 9 **SSM**: Software slave management

When the SSM bit is set, the NSS pin input is replaced with the value from the SSI bit.

0: Software slave management disabled

1: Software slave management enabled

*Note: Not used in I<sup>2</sup>S mode*

Bit 8 **SSI**: Internal slave select

This bit has an effect only when the SSM bit is set. The value of this bit is forced onto the NSS pin and the IO value of the NSS pin is ignored.

*Note:* **Not used in I<sup>2</sup>S mode**

Bit 7 **LSBFIRST**: Frame format

0: MSB transmitted first

1: LSB transmitted first

*Note:* This bit should not be changed when communication is ongoing.

**Not used in I<sup>2</sup>S mode**

Bit 6 **SPE**: SPI enable

0: Peripheral disabled

1: Peripheral enabled

*Note:* **1- Not used in I<sup>2</sup>S mode.**

*Note:* **2-** When disabling the SPI, follow the procedure described in [Section 24.3.8: Disabling the SPI](#).

Bits 5:3 **BR[2:0]**: Baud rate control

000: f<sub>PCLK</sub>/2

001: f<sub>PCLK</sub>/4

010: f<sub>PCLK</sub>/8

011: f<sub>PCLK</sub>/16

100: f<sub>PCLK</sub>/32

101: f<sub>PCLK</sub>/64

110: f<sub>PCLK</sub>/128

111: f<sub>PCLK</sub>/256

*Note:* These bits should not be changed when communication is ongoing.

**Not used in I<sup>2</sup>S mode**

Bit 2 **MSTR**: Master selection

0: Slave configuration

1: Master configuration

*Note:* This bit should not be changed when communication is ongoing.

**Not used in I<sup>2</sup>S mode**

Bit1 **CPOL**: Clock polarity

0: CK to 0 when idle

1: CK to 1 when idle

*Note:* This bit should not be changed when communication is ongoing.

**Not used in I<sup>2</sup>S mode**

Bit 0 **CPHA**: Clock phase

0: The first clock transition is the first data capture edge

1: The second clock transition is the first data capture edge

*Note:* This bit should not be changed when communication is ongoing.

*Note:* **Not used in I<sup>2</sup>S mode**

### 24.5.2 SPI control register 2 (SPI\_CR2)

Address offset: 0x04

Reset value: 0x0000

15	14	13	12	11	10	9	8	7	6	5	4	3	2	1	0	
Reserved								TXEIE	RXNEIE	ERRIE	Reserved			SSOE	TXDMAEN	RXDMAEN
								rw	rw	rw				rw	rw	rw

Bits 15:8 Reserved. Forced to 0 by hardware.

Bit 7 **TXEIE**: Tx buffer empty interrupt enable

0: TXE interrupt masked

1: TXE interrupt not masked. Used to generate an interrupt request when the TXE flag is set.

Bit 6 **RXNEIE**: RX buffer not empty interrupt enable

0: RXNE interrupt masked

1: RXNE interrupt not masked. Used to generate an interrupt request when the RXNE flag is set.

Bit 5 **ERRIE**: Error interrupt enable

This bit controls the generation of an interrupt when an error condition occurs (CRCERR, OVR, MODF in SPI mode and UDR, OVR in I<sup>2</sup>S mode).

0: Error interrupt is masked

1: Error interrupt is enabled.

Bits 4:3 Reserved. Forced to 0 by hardware.

Bit 2 **SSOE**: SS output enable

0: SS output is disabled in master mode and the cell can work in multimaster configuration

1: SS output is enabled in master mode and when the cell is enabled. The cell cannot work in a multimaster environment.

*Note: Not used in I<sup>2</sup>S mode*

Bit 1 **TXDMAEN**: Tx buffer DMA enable

When this bit is set, the DMA request is made whenever the TXE flag is set.

0: Tx buffer DMA disabled

1: Tx buffer DMA enabled

Bit 0 **RXDMAEN**: Rx buffer DMA enable

When this bit is set, the DMA request is made whenever the RXNE flag is set.

0: Rx buffer DMA disabled

1: Rx buffer DMA enabled

### 24.5.3 SPI status register (SPI\_SR)

Address offset: 0x08

Reset value: 0x0002

15	14	13	12	11	10	9	8	7	6	5	4	3	2	1	0
Reserved								BSY	OVR	MODF	CRC ERR	UDR	CHSID E	TXE	RXNE
								r	r	r	rc_w0	r	r	r	r

Bits 15:8 Reserved. Forced to 0 by hardware.

- Bit 7 **BSY**: Busy flag  
0: SPI (or I2S) not busy  
1: SPI (or I2S) is busy in communication or Tx buffer is not empty  
This flag is set and cleared by hardware.  
*Note: BSY flag must be used with caution: refer to [Section 24.3.7: Status flags](#) and [Section 24.3.8: Disabling the SPI](#).*
- Bit 6 **OVR**: Overrun flag  
0: No overrun occurred  
1: Overrun occurred  
This flag is set by hardware and reset by a software sequence. Refer to [Section 24.4.7 on page 692](#) for the software sequence.
- Bit 5 **MODF**: Mode fault  
0: No mode fault occurred  
1: Mode fault occurred  
This flag is set by hardware and reset by a software sequence. Refer to [Section 24.3.10 on page 674](#) for the software sequence.  
*Note: Not used in I<sup>2</sup>S mode*
- Bit 4 **CRCERR**: CRC error flag  
0: CRC value received matches the SPI\_RXCRCR value  
1: CRC value received does not match the SPI\_RXCRCR value  
This flag is set by hardware and cleared by software writing 0.  
*Note: Not used in I<sup>2</sup>S mode*
- Bit 3 **UDR**: Underrun flag  
0: No underrun occurred  
1: Underrun occurred  
This flag is set by hardware and reset by a software sequence. Refer to [Section 24.4.7 on page 692](#) for the software sequence.  
*Note: Not used in SPI mode*
- Bit 2 **CHSIDE**: Channel side  
0: Channel Left has to be transmitted or has been received  
1: Channel Right has to be transmitted or has been received  
*Note: Not used for the SPI mode. No meaning in PCM mode*
- Bit 1 **TXE**: Transmit buffer empty  
0: Tx buffer not empty  
1: Tx buffer empty
- Bit 0 **RXNE**: Receive buffer not empty  
0: Rx buffer empty  
1: Rx buffer not empty



### 24.5.4 SPI data register (SPI\_DR)

Address offset: 0x0C

Reset value: 0x0000

15	14	13	12	11	10	9	8	7	6	5	4	3	2	1	0
DR[15:0]															
rw	rw	rw	rw	rw	rw	rw	rw	rw	rw	rw	rw	rw	rw	rw	rw

Bits 15:0 **DR[15:0]**: Data register

Data received or to be transmitted.

The data register is split into 2 buffers - one for writing (Transmit Buffer) and another one for reading (Receive buffer). A write to the data register will write into the Tx buffer and a read from the data register will return the value held in the Rx buffer.

**Notes for the SPI mode:**

*Depending on the data frame format selection bit (DFF in SPI\_CR1 register), the data sent or received is either 8-bit or 16-bit. This selection has to be made before enabling the SPI to ensure correct operation.*

*For an 8-bit data frame, the buffers are 8-bit and only the LSB of the register (SPI\_DR[7:0]) is used for transmission/reception. When in reception mode, the MSB of the register (SPI\_DR[15:8]) is forced to 0.*

*For a 16-bit data frame, the buffers are 16-bit and the entire register, SPI\_DR[15:0] is used for transmission/reception.*

### 24.5.5 SPI CRC polynomial register (SPI\_CRCPR) (not used in I<sup>2</sup>S mode)

Address offset: 0x10

Reset value: 0x0007

15	14	13	12	11	10	9	8	7	6	5	4	3	2	1	0
CRCPOLY[15:0]															
rw	rw	rw	rw	rw	rw	rw	rw	rw	rw	rw	rw	rw	rw	rw	rw

Bits 15:0 **CRCPOLY[15:0]**: CRC polynomial register

This register contains the polynomial for the CRC calculation.

The CRC polynomial (0007h) is the reset value of this register. Another polynomial can be configured as required.

*Note: Not used for the I<sup>2</sup>S mode.*

### 24.5.6 SPI Rx CRC register (SPI\_RXCRCR) (not used in I<sup>2</sup>S mode)

Address offset: 0x14

Reset value: 0x0000

15	14	13	12	11	10	9	8	7	6	5	4	3	2	1	0
RxCRC[15:0]															
r	r	r	r	r	r	r	r	r	r	r	r	r	r	r	r

Bits 15:0 **RxCRC[15:0]**: Rx CRC register

When CRC calculation is enabled, the RxCRC[15:0] bits contain the computed CRC value of the subsequently received bytes. This register is reset when the CRCEN bit in SPI\_CR1 register is written to 1. The CRC is calculated serially using the polynomial programmed in the SPI\_CRCPR register.

Only the 8 LSB bits are considered when the data frame format is set to be 8-bit data (DFF bit of SPI\_CR1 is cleared). CRC calculation is done based on any CRC8 standard.

The entire 16-bits of this register are considered when a 16-bit data frame format is selected (DFF bit of the SPI\_CR1 register is set). CRC calculation is done based on any CRC16 standard.

*Note: A read to this register when the BSY Flag is set could return an incorrect value. Not used for the I<sup>2</sup>S mode.*

### 24.5.7 SPI Tx CRC register (SPI\_TXCRCR) (not used in I<sup>2</sup>S mode)

Address offset: 0x18

Reset value: 0x0000

15	14	13	12	11	10	9	8	7	6	5	4	3	2	1	0
TxCRC[15:0]															
r	r	r	r	r	r	r	r	r	r	r	r	r	r	r	r

Bits 15:0 **TxCRC[15:0]**: Tx CRC register

When CRC calculation is enabled, the TxCRC[7:0] bits contain the computed CRC value of the subsequently transmitted bytes. This register is reset when the CRCEN bit of SPI\_CR1 is written to 1. The CRC is calculated serially using the polynomial programmed in the SPI\_CRCPR register.

Only the 8 LSB bits are considered when the data frame format is set to be 8-bit data (DFF bit of SPI\_CR1 is cleared). CRC calculation is done based on any CRC8 standard.

The entire 16-bits of this register are considered when a 16-bit data frame format is selected (DFF bit of the SPI\_CR1 register is set). CRC calculation is done based on any CRC16 standard.

*Note: A read to this register when the BSY flag is set could return an incorrect value. Not used for the I<sup>2</sup>S mode.*

### 24.5.8 SPI\_I<sup>2</sup>S configuration register (SPI\_I2SCFGR)

Address offset: 0x1C

Reset value: 0x0000

15	14	13	12	11	10	9	8	7	6	5	4	3	2	1	0
Reserved				I2SMOD	I2SE	I2SCFG		PCMSY NC	Reserved	I2SSTD		CKPOL	DATLEN		CHLEN
				rw	rw	rw	rw	rw		rw	rw	rw	rw	rw	rw

Bits 15:12 Reserved: Forced to 0 by hardware

Bit 11 **I2SMOD**: I2S mode selection

0: SPI mode is selected

1: I2S mode is selected

*Note: This bit should be configured when the SPI or I<sup>2</sup>S is disabled*

Bit 10 **I2SE**: I2S Enable

0: I<sup>2</sup>S peripheral is disabled

1: I<sup>2</sup>S peripheral is enabled

*Note: Not used in SPI mode*

Bit 9:8 **I2SCFG**: I2S configuration mode

00: Slave - transmit

01: Slave - receive

10: Master - transmit

11: Master - receive

*Note: This bit should be configured when the I<sup>2</sup>S is disabled.*

*Not used for the SPI mode*

Bit 7 **PCMSYNC**: PCM frame synchronization

0: Short frame synchronization

1: Long frame synchronization

*Note: This bit has a meaning only if I2SSTD = 11 (PCM standard is used)*

*Not used for the SPI mode*

Bit 6 Reserved: forced at 0 by hardware

Bit 5:4 **I2SSTD**: I2S standard selection

00: I<sup>2</sup>S Phillips standard.

01: MSB justified standard (left justified)

10: LSB justified standard (right justified)

11: PCM standard

For more details on I<sup>2</sup>S standards, refer to [Section 24.4.2 on page 677](#)

*Note: For correct operation, these bits should be configured when the I<sup>2</sup>S is disabled.*

*Not used in SPI mode*

Bit 3 **CKPOL**: Steady state clock polarity

0: I<sup>2</sup>S clock steady state is low level

1: I<sup>2</sup>S clock steady state is high level

*Note: For correct operation, this bit should be configured when the I<sup>2</sup>S is disabled.*

*Not used in SPI mode*

Bit 2:1 **DATLEN**: Data length to be transferred

- 00: 16-bit data length
- 01: 24-bit data length
- 10: 32-bit data length
- 11: Not allowed

*Note: For correct operation, these bits should be configured when the I<sup>2</sup>S is disabled.  
Not used in SPI mode*

Bit 0 **CHLEN**: Channel length (number of bits per audio channel)

- 0: 16-bit wide
- 1: 32-bit wide

The bit write operation has a meaning only if DATLEN = 00 otherwise the channel length is fixed to 32-bit by hardware whatever the value filled in.

*Note: For correct operation, this bit should be configured when the I<sup>2</sup>S is disabled.  
Not used in SPI mode*

### 24.5.9 SPI\_I<sup>2</sup>S prescaler register (SPI\_I2SPR)

Address offset: 0x20

Reset value: 0000 0010 (0x0002)

15	14	13	12	11	10	9	8	7	6	5	4	3	2	1	0
Reserved						MCKOE	ODD	I2SDIV							
						rw	rw	rw							

Bits 15:10 Reserved: Forced to 0 by hardware

Bit 9 **MCKOE**: Master clock output enable

- 0: Master clock output is disabled
- 1: Master clock output is enabled

*Note: This bit should be configured when the I<sup>2</sup>S is disabled. It is used only when the I<sup>2</sup>S is in master mode.*

*Not used in SPI mode.*

Bit 8 **ODD**: Odd factor for the prescaler

- 0: real divider value is = I2SDIV \*2
- 1: real divider value is = (I2SDIV \* 2)+1

Refer to [Section 24.4.3 on page 684](#)

*Note: This bit should be configured when the I<sup>2</sup>S is disabled. It is used only when the I<sup>2</sup>S is in master mode.*

*Not used in SPI mode*

Bit 7:0 **I2SDIV**: I2S Linear prescaler

I2SDIV [7:0] = 0 or I2SDIV [7:0] = 1 are forbidden values.

Refer to [Section 24.4.3 on page 684](#)

*Note: These bits should be configured when the I<sup>2</sup>S is disabled. It is used only when the I<sup>2</sup>S is in master mode.*

*Not used in SPI mode.*

### 24.5.10 SPI register map

The table provides shows the SPI register map and reset values.

**Table 184. SPI register map and reset values**

Offset	Register	31	30	29	28	27	26	25	24	23	22	21	20	19	18	17	16	15	14	13	12	11	10	9	8	7	6	5	4	3	2	1	0																		
0x00	SPI_CR1	Reserved																	BIDIMODE	BIDIOE	CRGEN	CRCNEXT	DFE	FXONLY	SSM	SSI	LSBFIRST	SPE	BR	[2:0]		MSTR	CPOL	CPHA																	
	Reset value	0																	0	0	0	0	0	0	0	0	0	0	0	0	0	0	0	0	0	0	0	0	0	0	0	0	0	0	0	0	0	0			
0x04	SPI_CR2	Reserved																	TXEIE	RXNEIE	ERRIE	Reserved		SSEE	TXDMAEN	RXDMAEN																									
	Reset value	0																	0	0	0	0	0	0	0	0	0	0	0	0	0	0	0	0	0	0	0	0	0	0	0	0	0	0	0	0	0	0			
0x08	SPI_SR	Reserved																	BSY	OVR	MODF	CRCEERR	UDR	CHSIDE	TXE	RXNE																									
	Reset value	0																	0	0	0	0	0	0	0	0	0	0	0	0	0	0	0	0	0	0	0	0	0	0	0	0	0	0	0	0	0	0	0		
0x0C	SPI_DR	Reserved																	DR[15:0]																																
	Reset value	0																	0	0	0	0	0	0	0	0	0	0	0	0	0	0	0	0	0	0	0	0	0	0	0	0	0	0	0	0	0	0	0	0	
0x10	SPI_CRCPR	Reserved																	CRCPOLY[15:0]																																
	Reset value	0																	0	0	0	0	0	0	0	0	0	0	0	0	0	0	0	0	0	0	0	0	0	0	0	0	0	0	0	0	0	0	0	0	0
0x14	SPI_RXCR	Reserved																	RxCRC[15:0]																																
	Reset value	0																	0	0	0	0	0	0	0	0	0	0	0	0	0	0	0	0	0	0	0	0	0	0	0	0	0	0	0	0	0	0	0	0	0
0x18	SPI_TXCR	Reserved																	TxCRC[15:0]																																
	Reset value	0																	0	0	0	0	0	0	0	0	0	0	0	0	0	0	0	0	0	0	0	0	0	0	0	0	0	0	0	0	0	0	0	0	0
0x1C	SPI_I2SCFGR	Reserved																	I2SMOD	I2SE	I2SCFG	PCMSYNC	Reserved		I2SSTD	CKPOL	DATLEN	CHLEN																							
	Reset value	0																	0	0	0	0	0	0	0	0	0	0	0	0	0	0	0	0	0	0	0	0	0	0	0	0	0	0	0	0	0	0	0	0	0
0x20	SPI_I2SPR	Reserved																	MCKOE	ODD	I2SDIV																														
	Reset value	0																	0	0	0	0	0	0	0	0	0	0	0	0	0	0	0	0	0	0	0	0	0	0	0	0	0	0	0	0	0	0	0	0	0

Note: Refer to Register boundary addresses table.

## 25 Inter-integrated circuit (I<sup>2</sup>C) interface

**Low-density devices** are STM32F101xx, STM32F102xx and STM32F103xx microcontrollers where the Flash memory density ranges between 16 and 32 Kbytes.

**Medium-density devices** are STM32F101xx, STM32F102xx and STM32F103xx microcontrollers where the Flash memory density ranges between 64 and 128 Kbytes.

**High-density devices** are STM32F101xx and STM32F103xx microcontrollers where the Flash memory density ranges between 256 and 512 Kbytes.

**XL-density devices** are STM32F101xx and STM32F103xx microcontrollers where the Flash memory density ranges between 768 Kbytes and 1 Mbyte.

**Connectivity line devices** are STM32F105xx and STM32F107xx microcontrollers.

This section applies to the whole STM32F10xxx family, unless otherwise specified.

### 25.1 I<sup>2</sup>C introduction

I<sup>2</sup>C (inter-integrated circuit) bus Interface serves as an interface between the microcontroller and the serial I<sup>2</sup>C bus. It provides multimaster capability, and controls all I<sup>2</sup>C bus-specific sequencing, protocol, arbitration and timing. It supports standard and fast speed modes. It is also SMBus 2.0 compatible.

It may be used for a variety of purposes, including CRC generation and verification, SMBus (system management bus) and PMBus (power management bus).

Depending on specific device implementation DMA capability can be available for reduced CPU overload.

### 25.2 I<sup>2</sup>C main features

- Parallel-bus/I<sup>2</sup>C protocol converter
- Multimaster capability: the same interface can act as Master or Slave
- I<sup>2</sup>C Master features:
  - Clock generation
  - Start and Stop generation
- I<sup>2</sup>C Slave features:
  - Programmable I<sup>2</sup>C Address detection
  - Dual Addressing Capability to acknowledge 2 slave addresses
  - Stop bit detection
- Generation and detection of 7-bit/10-bit addressing and General Call
- Supports different communication speeds:
  - Standard Speed (up to 100 kHz),
  - Fast Speed (up to 400 kHz)
- Status flags:
  - Transmitter/Receiver mode flag
  - End-of-Byte transmission flag

- I<sup>2</sup>C busy flag
- Error flags:
  - Arbitration lost condition for master mode
  - Acknowledgement failure after address/ data transmission
  - Detection of misplaced start or stop condition
  - Overrun/Underrun if clock stretching is disabled
- 2 Interrupt vectors:
  - 1 Interrupt for successful address/ data communication
  - 1 Interrupt for error condition
- Optional Clock Stretching
- 1-byte buffer with DMA capability
- Configurable PEC (Packet Error Checking) Generation or Verification:
  - PEC value can be transmitted as last byte in Tx mode
  - PEC error checking for last received byte
- SMBus 2.0 Compatibility:
  - 25 ms clock low timeout delay
  - 10 ms master cumulative clock low extend time
  - 25 ms slave cumulative clock low extend time
  - Hardware PEC generation/verification with ACK control
  - Address Resolution Protocol (ARP) supported
- PMBus Compatibility

*Note:* Some of the above features may not be available in certain products. The user should refer to the product data sheet, to identify the specific features supported by the I<sup>2</sup>C interface implementation.

## 25.3 I<sup>2</sup>C functional description

In addition to receiving and transmitting data, this interface converts it from serial to parallel format and vice versa. The interrupts are enabled or disabled by software. The interface is connected to the I<sup>2</sup>C bus by a data pin (SDA) and by a clock pin (SCL). It can be connected with a standard (up to 100 kHz) or fast (up to 400 kHz) I<sup>2</sup>C bus.

### 25.3.1 Mode selection

The interface can operate in one of the four following modes:

- Slave transmitter
- Slave receiver
- Master transmitter
- Master receiver

By default, it operates in slave mode. The interface automatically switches from slave to master, after it generates a START condition and from master to slave, if an arbitration loss or a Stop generation occurs, allowing multimaster capability.

### Communication flow

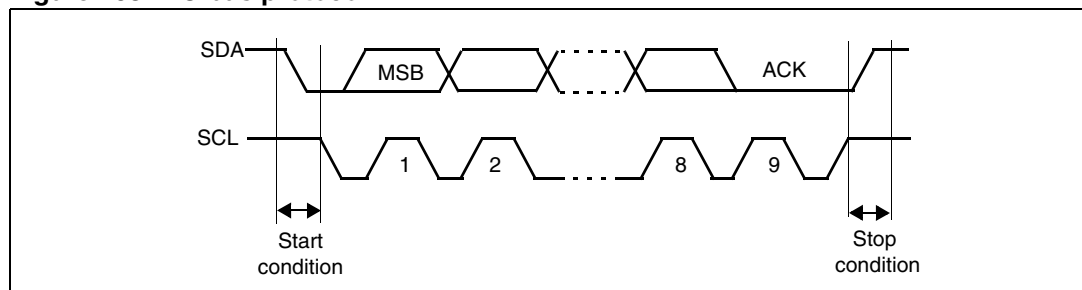
In Master mode, the I<sup>2</sup>C interface initiates a data transfer and generates the clock signal. A serial data transfer always begins with a start condition and ends with a stop condition. Both start and stop conditions are generated in master mode by software.

In Slave mode, the interface is capable of recognizing its own addresses (7 or 10-bit), and the General Call address. The General Call address detection may be enabled or disabled by software.

Data and addresses are transferred as 8-bit bytes, MSB first. The first byte(s) following the start condition contain the address (one in 7-bit mode, two in 10-bit mode). The address is always transmitted in Master mode.

A 9th clock pulse follows the 8 clock cycles of a byte transfer, during which the receiver must send an acknowledge bit to the transmitter. Refer to the following figure.

**Figure 268. I<sup>2</sup>C bus protocol**

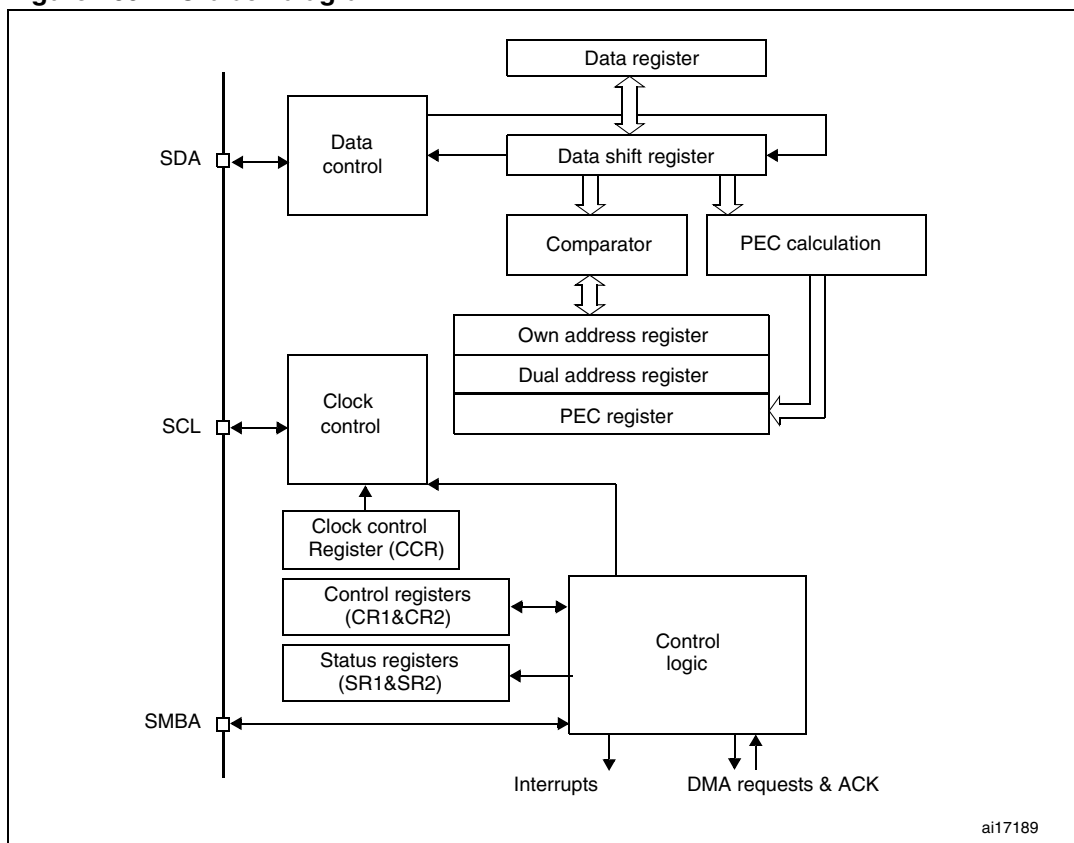


Acknowledge may be enabled or disabled by software. The I<sup>2</sup>C interface addresses (dual addressing 7-bit/ 10-bit and/or general call address) can be selected by software.

The block diagram of the I<sup>2</sup>C interface is shown in [Figure 269](#).



Figure 269. I<sup>2</sup>C block diagram



1. SMBA is an optional signal in SMBus mode. This signal is not applicable if SMBus is disabled.

### 25.3.2 I<sup>2</sup>C slave mode

By default the I<sup>2</sup>C interface operates in Slave mode. To switch from default Slave mode to Master mode a Start condition generation is needed.

The peripheral input clock must be programmed in the I2C\_CR2 register in order to generate correct timings. The peripheral input clock frequency must be at least:

- 2 MHz in Standard mode
- 4 MHz in Fast mode

As soon as a start condition is detected, the address is received from the SDA line and sent to the shift register. Then it is compared with the address of the interface (OAR1) and with OAR2 (if ENDUAL=1) or the General Call address (if ENGC = 1).

*Note:* In 10-bit addressing mode, the comparison includes the header sequence (11110xx0), where xx denotes the two most significant bits of the address.

**Header or address not matched:** the interface ignores it and waits for another Start condition.

**Header matched (10-bit mode only):** the interface generates an acknowledge pulse if the ACK bit is set and waits for the 8-bit slave address.

**Address matched:** the interface generates in sequence:

- An acknowledge pulse if the ACK bit is set
- The ADDR bit is set by hardware and an interrupt is generated if the ITEVFEN bit is set.
- If ENDUAL=1, the software has to read the DUALF bit to check which slave address has been acknowledged.

In 10-bit mode, after receiving the address sequence the slave is always in Receiver mode. It will enter Transmitter mode on receiving a repeated Start condition followed by the header sequence with matching address bits and the least significant bit set (11110xx1).

The TRA bit indicates whether the slave is in Receiver or Transmitter mode.

**Slave transmitter**

Following the address reception and after clearing ADDR, the slave sends bytes from the DR register to the SDA line via the internal shift register.

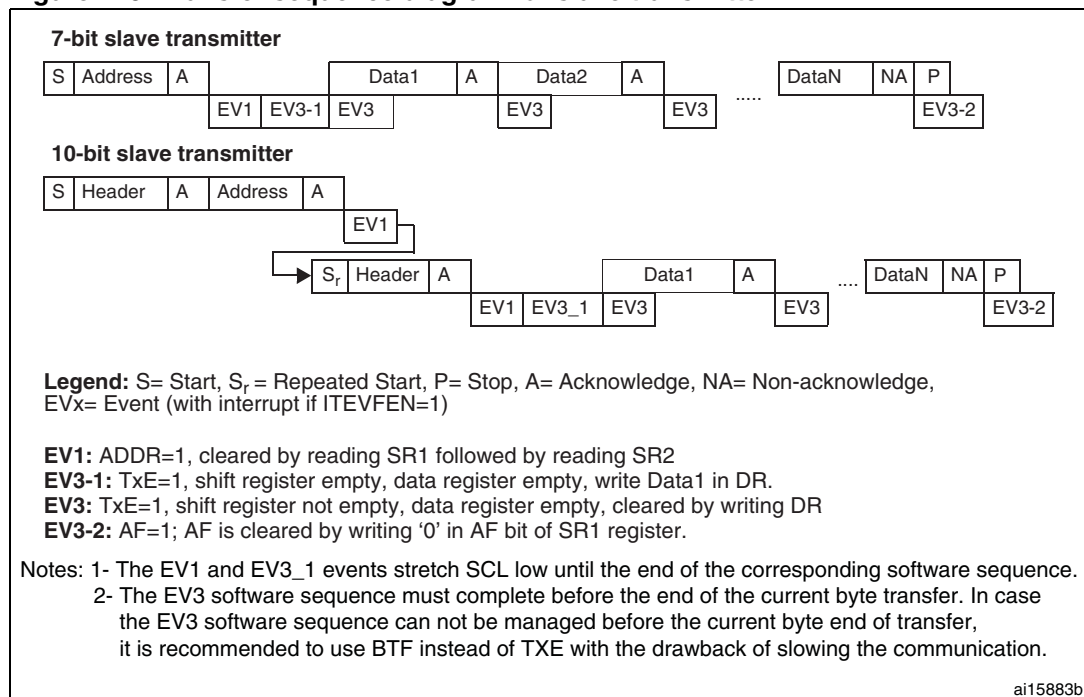
The slave stretches SCL low until ADDR is cleared and DR filled with the data to be sent (see *Figure 270* Transfer sequencing EV1 EV3).

When the acknowledge pulse is received:

- The TxE bit is set by hardware with an interrupt if the ITEVFEN and the ITBUFEN bits are set.

If TxE is set and some data were not written in the I2C\_DR register before the end of the next data transmission, the BTF bit is set and the interface waits until BTF is cleared by a read to I2C\_SR1 followed by a write to the I2C\_DR register, stretching SCL low.

**Figure 270. Transfer sequence diagram for slave transmitter**



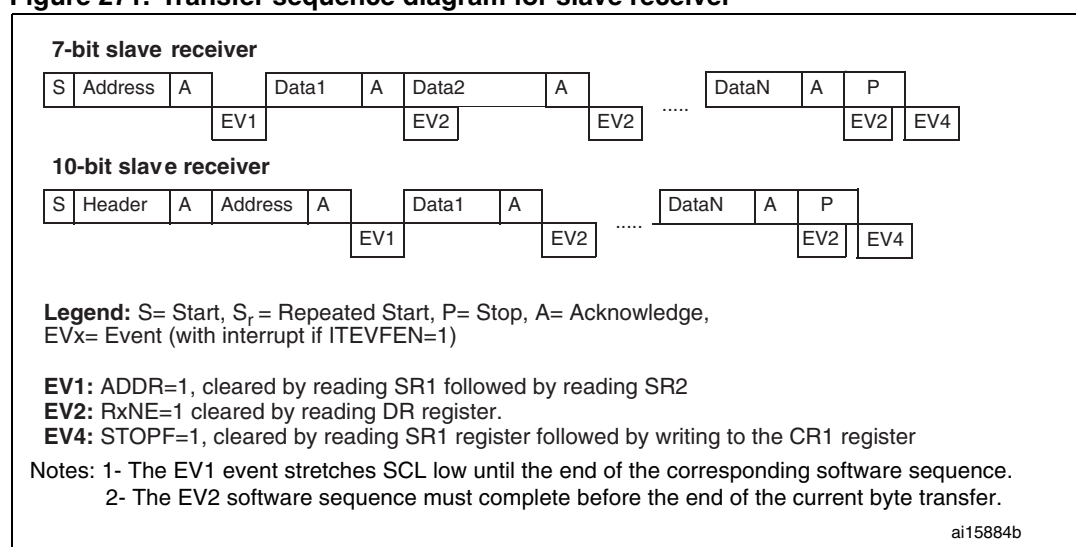
### Slave receiver

Following the address reception and after clearing ADDR, the slave receives bytes from the SDA line into the DR register via the internal shift register. After each byte the interface generates in sequence:

- An acknowledge pulse if the ACK bit is set
- The RxNE bit is set by hardware and an interrupt is generated if the ITEVFEN and ITBUFEN bit is set.

If RxNE is set and the data in the DR register is not read before the end of the next data reception, the BTF bit is set and the interface waits until BTF is cleared by a read from I2C\_SR1 followed by a read from the I2C\_DR register, stretching SCL low (see [Figure 271](#) Transfer sequencing).

**Figure 271. Transfer sequence diagram for slave receiver**



### Closing slave communication

After the last data byte is transferred a Stop Condition is generated by the master. The interface detects this condition and sets,

- The STOPF bit and generates an interrupt if the ITEVFEN bit is set.

Then the interface waits for a read of the SR1 register followed by a write to the CR1 register (see [Figure 271](#) Transfer sequencing EV4).

## 25.3.3 I<sup>2</sup>C master mode

In Master mode, the I<sup>2</sup>C interface initiates a data transfer and generates the clock signal. A serial data transfer always begins with a Start condition and ends with a Stop condition. Master mode is selected as soon as the Start condition is generated on the bus with a START bit.

The following is the required sequence in master mode.

- Program the peripheral input clock in I2C\_CR2 Register in order to generate correct timings
- Configure the clock control registers
- Configure the rise time register
- Program the I2C\_CR1 register to enable the peripheral
- Set the START bit in the I2C\_CR1 register to generate a Start condition

The peripheral input clock frequency must be at least:

- 2 MHz in Standard mode
- 4 MHz in Fast mode

### Start condition

Setting the START bit causes the interface to generate a Start condition and to switch to Master mode (M/SL bit set) when the BUSY bit is cleared.

*Note:* In master mode, setting the START bit causes the interface to generate a ReStart condition at the end of the current byte transfer.

Once the Start condition is sent:

- The SB bit is set by hardware and an interrupt is generated if the ITEVFEN bit is set.

Then the master waits for a read of the SR1 register followed by a write in the DR register with the Slave address (see [Figure 272](#) & [Figure 273](#) Transfer sequencing EV5).

### Slave address transmission

Then the slave address is sent to the SDA line via the internal shift register.

- In 10-bit addressing mode, sending the header sequence causes the following event:
  - The ADD10 bit is set by hardware and an interrupt is generated if the ITEVFEN bit is set.

Then the master waits for a read of the SR1 register followed by a write in the DR register with the second address byte (see [Figure 272](#) & [Figure 273](#) Transfer sequencing).

- The ADDR bit is set by hardware and an interrupt is generated if the ITEVFEN bit is set.

Then the master waits for a read of the SR1 register followed by a read of the SR2 register (see [Figure 272](#) & [Figure 273](#) Transfer sequencing).

- In 7-bit addressing mode, one address byte is sent.

As soon as the address byte is sent,

- The ADDR bit is set by hardware and an interrupt is generated if the ITEVFEN bit is set.

Then the master waits for a read of the SR1 register followed by a read of the SR2 register (see [Figure 272](#) & [Figure 273](#) Transfer sequencing).

The master can decide to enter Transmitter or Receiver mode depending on the LSB of the slave address sent.

- In 7-bit addressing mode,
  - To enter Transmitter mode, a master sends the slave address with LSB reset.
  - To enter Receiver mode, a master sends the slave address with LSB set.
- In 10-bit addressing mode,
  - To enter Transmitter mode, a master sends the header (11110xx0) and then the slave address, (where xx denotes the two most significant bits of the address).
  - To enter Receiver mode, a master sends the header (11110xx0) and then the slave address. Then it should send a repeated Start condition followed by the header (11110xx1), (where xx denotes the two most significant bits of the address).

The TRA bit indicates whether the master is in Receiver or Transmitter mode.

### Master transmitter

Following the address transmission and after clearing ADDR, the master sends bytes from the DR register to the SDA line via the internal shift register.

The master waits until the first data byte is written into I2C\_DR (see [Figure 272](#) Transfer sequencing EV8\_1).

When the acknowledge pulse is received:

- The TxE bit is set by hardware and an interrupt is generated if the ITEVFEN and ITBUFEN bits are set.

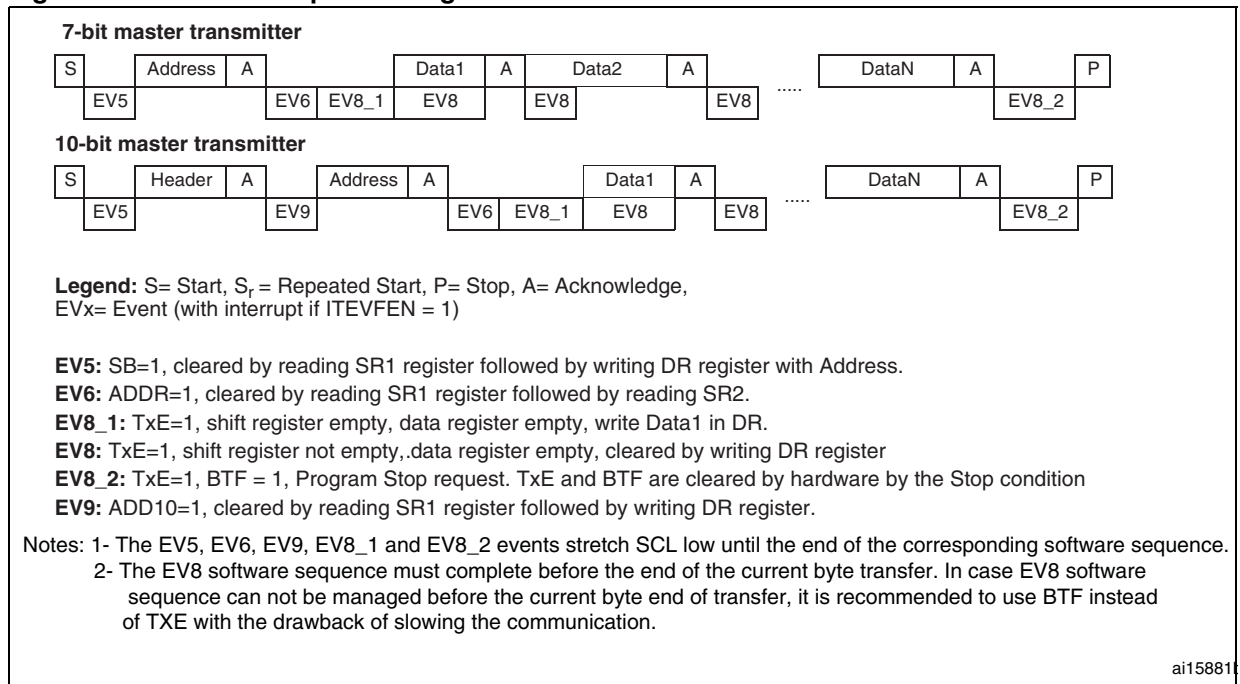
If TxE is set and a data byte was not written in the DR register before the end of the last data transmission, BTF is set and the interface waits until BTF is cleared by a read from I2C\_SR1 followed by a write to I2C\_DR, stretching SCL low.

### Closing the communication

After the last byte is written to the DR register, the STOP bit is set by software to generate a Stop condition (see [Figure 272](#) Transfer sequencing EV8\_2). The interface automatically goes back to slave mode (M/SL bit cleared).

*Note:* Stop condition should be programmed during EV8\_2 event, when either TxE or BTF is set.

**Figure 272. Transfer sequence diagram for master transmitter**



### Master receiver

Following the address transmission and after clearing ADDR, the I<sup>2</sup>C interface enters Master Receiver mode. In this mode the interface receives bytes from the SDA line into the DR register via the internal shift register. After each byte the interface generates in sequence:

- An acknowledge pulse if the ACK bit is set
- The RxNE bit is set and an interrupt is generated if the ITEVFEN and ITBUFEN bits are set (see [Figure 273](#) Transfer sequencing EV7).

If the RxNE bit is set and the data in the DR register is not read before the end of the last data reception, the BTF bit is set by hardware and the interface waits until BTF is cleared by a read in the SR1 register followed by a read in the DR register, stretching SCL low.

### Closing the communication

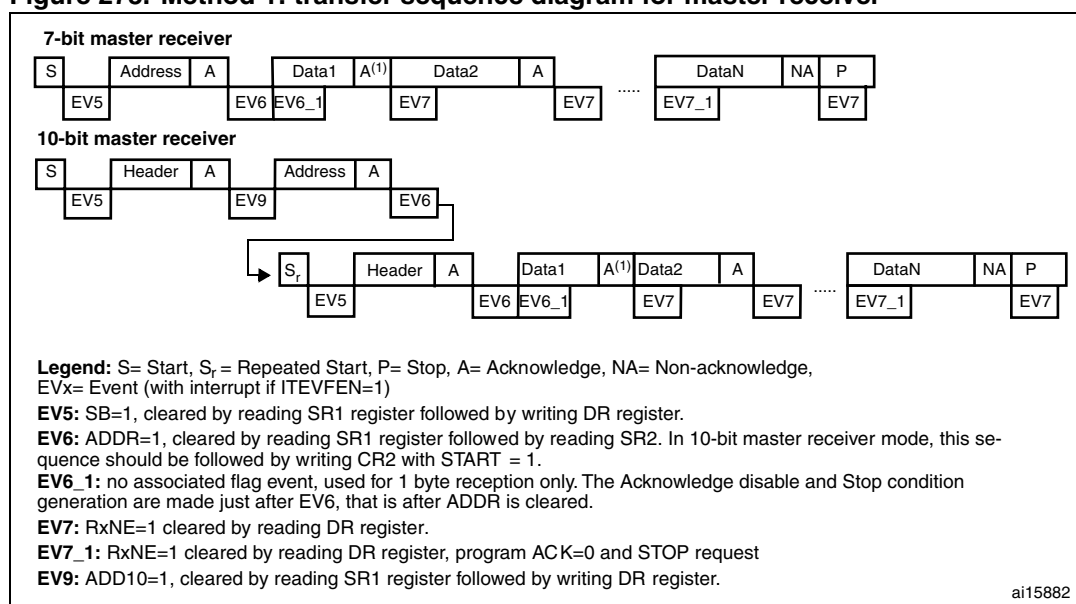
**Method 1:** This method is for the case when the I<sup>2</sup>C is used with interrupts that have the highest priority in the application.

The master sends a NACK for the last byte received from the slave. After receiving this NACK, the slave releases the control of the SCL and SDA lines. Then the master can send a Stop/Re-Start condition.

- In order to generate the non-acknowledge pulse after the last received data byte, the ACK bit must be cleared just after reading the second last data byte (after second last RxNE event).
- In order to generate the Stop/Re-Start condition, software must set the STOP/START bit just after reading the second last data byte (after the second last RxNE event).
- In case a single byte is to be received, the Acknowledge disable and the Stop condition generation are made just after EV6 (in EV6\_1, just after ADDR is cleared).

After the Stop condition generation, the interface goes automatically back to slave mode (M/SL bit cleared).

**Figure 273. Method 1: transfer sequence diagram for master receiver**

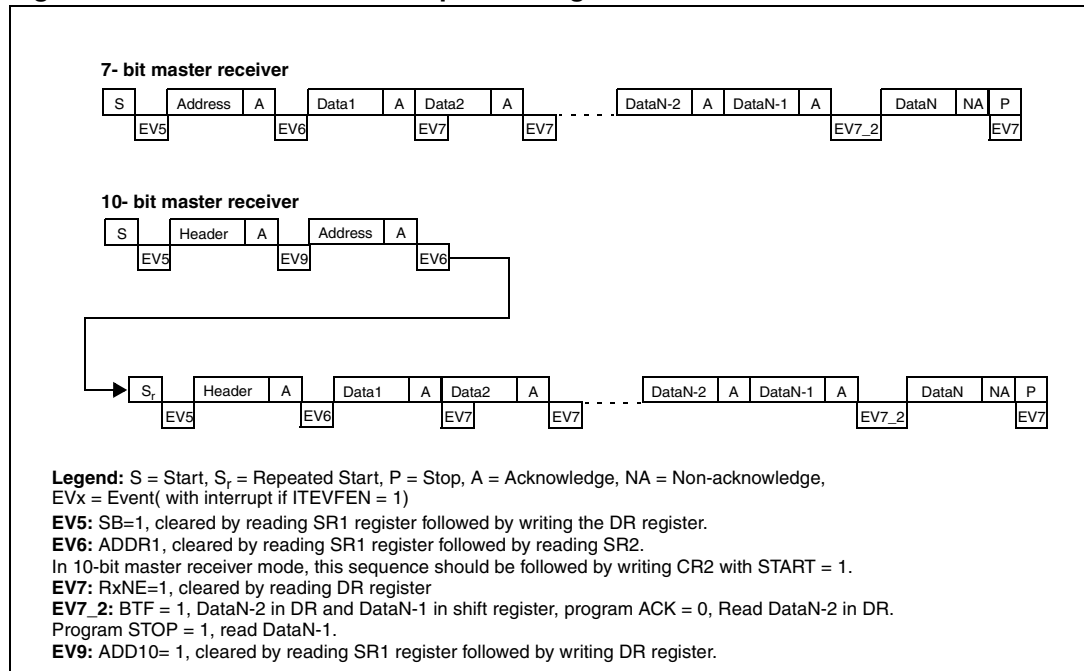


1. If a single byte is received, it is NA.
2. The EV5, EV6 and EV9 events stretch SCL low until the end of the corresponding software sequence.
3. The EV7 software sequence must complete before the end of the current byte transfer. In case EV7 software sequence can not be managed before the current byte end of transfer, it is recommended to use BTF instead of RXNE with the drawback of slowing the communication.
4. The EV6\_1 or EV7\_1 software sequence must complete before the ACK pulse of the current byte transfer.

**Method 2:** This method is for the case when the I<sup>2</sup>C is used with interrupts that do not have the highest priority in the application or when the I<sup>2</sup>C is used with polling.

With this method, DataN\_2 is not read, so that after DataN\_1, the communication is stretched (both RxNE and BTF are set). Then, clear the ACK bit before reading DataN-2 in DR to ensure it is be cleared before the DataN Acknowledge pulse. After that, just after reading DataN\_2, set the STOP/ START bit and read DataN\_1. After RxNE is set, read DataN. This is illustrated below:

**Figure 274. Method 2: transfer sequence diagram for master receiver when N>2**



1. The EV5, EV6 and EV9 events stretch SCL low until the end of the corresponding software sequence.
2. The EV7 software sequence must complete before the end of the current byte transfer. In case EV7 software sequence can not be managed before the current byte end of transfer, it is recommended to use BTF instead of RXNE with the drawback of slowing the communication.

When 3 bytes remain to be read:

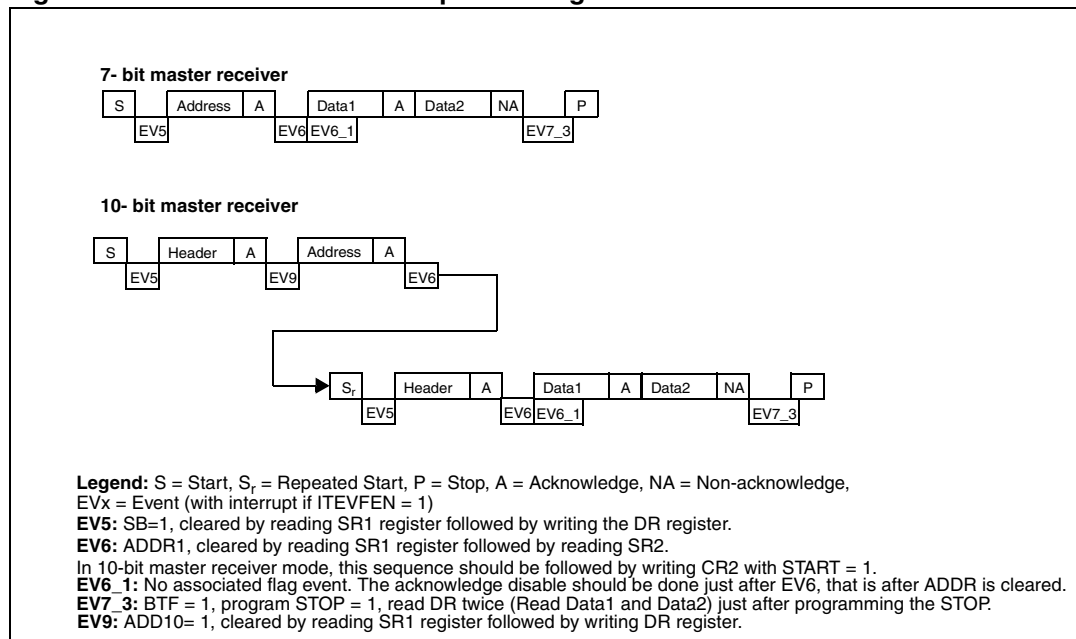
- RxNE = 1 => Nothing (DataN-2 not read).
- DataN-1 received
- BTF = 1 because both shift and data registers are full: DataN-2 in DR and DataN-1 in the shift register => SCL tied low: no other data will be received on the bus.
- Clear ACK bit
- Read DataN-2 in DR => This will launch the DataN reception in the shift register
- DataN received (with a NACK)
- Program START/STOP
- Read DataN-1
- RxNE = 1
- Read DataN



The procedure described above is valid for N>2. The cases where a single byte or two bytes are to be received should be handled differently, as described below:

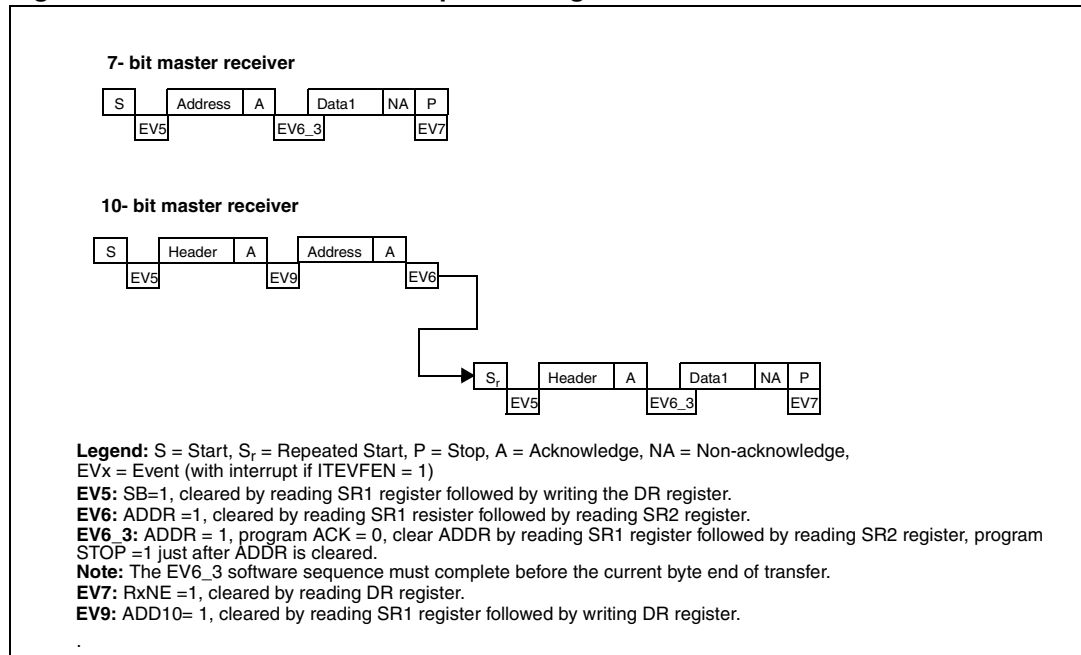
- Case of a single byte to be received:
  - In the ADDR event, clear the ACK bit.
  - Clear ADDR
  - Program the STOP/START bit.
  - Read the data after the RxNE flag is set.
- Case of two bytes to be received:
  - Set POS and ACK
  - Wait for the ADDR flag to be set
  - Clear ADDR
  - Clear ACK
  - Wait for BTF to be set
  - Program STOP
  - Read DR twice

**Figure 275. Method 2: transfer sequence diagram for master receiver when N=2**



1. The EV5, EV6 and EV9 events stretch SCL low until the end of the corresponding software sequence.
2. The EV6\_1 software sequence must complete before the ACK pulse of the current byte transfer.

**Figure 276. Method 2: transfer sequence diagram for master receiver when N=1**



1. The EV5, EV6 and EV9 events stretch SCL low until the end of the corresponding software sequence.

### 25.3.4 Error conditions

The following are the error conditions which may cause communication to fail.

#### Bus error (BERR)

This error occurs when the I<sup>2</sup>C interface detects an external Stop or Start condition during an address or a data transfer. In this case:

- the BERR bit is set and an interrupt is generated if the ITERREN bit is set
- in Slave mode: data are discarded and the lines are released by hardware:
  - in case of a misplaced Start, the slave considers it is a restart and waits for an address, or a Stop condition
  - in case of a misplaced Stop, the slave behaves like for a Stop condition and the lines are released by hardware
- In Master mode: the lines are not released and the state of the current transmission is not affected. It is up to the software to abort or not the current transmission

#### Acknowledge failure (AF)

This error occurs when the interface detects a non-acknowledge bit. In this case:

- the AF bit is set and an interrupt is generated if the ITERREN bit is set
- a transmitter which receives a NACK must reset the communication:
  - If Slave: lines are released by hardware
  - If Master: a Stop or repeated Start condition must be generated by software

### Arbitration lost (ARLO)

This error occurs when the I<sup>2</sup>C interface detects an arbitration lost condition. In this case,

- the ARLO bit is set by hardware (and an interrupt is generated if the ITERREN bit is set)
- the I<sup>2</sup>C Interface goes automatically back to slave mode (the M/SL bit is cleared). When the I<sup>2</sup>C loses the arbitration, it is not able to acknowledge its slave address in the same transfer, but it can acknowledge it after a repeated Start from the winning master.
- lines are released by hardware

### Overrun/underrun error (OVR)

An overrun error can occur in slave mode when clock stretching is disabled and the I<sup>2</sup>C interface is receiving data. The interface has received a byte (RxNE=1) and the data in DR has not been read, before the next byte is received by the interface. In this case,

- The last received byte is lost.
- In case of Overrun error, software should clear the RxNE bit and the transmitter should re-transmit the last received byte.

Underrun error can occur in slave mode when clock stretching is disabled and the I<sup>2</sup>C interface is transmitting data. The interface has not updated the DR with the next byte (TxE=1), before the clock comes for the next byte. In this case,

- The same byte in the DR register will be sent again
- The user should make sure that data received on the receiver side during an underrun error are discarded and that the next bytes are written within the clock low time specified in the I<sup>2</sup>C bus standard.

For the first byte to be transmitted, the DR must be written after ADDR is cleared and before the first SCL rising edge. If not possible, the receiver must discard the first data.

## 25.3.5 SDA/SCL line control

- If clock stretching is enabled:
  - Transmitter mode: If TxE=1 and BTF=1: the interface holds the clock line low before transmission to wait for the microcontroller to read SR1 and then write the byte in the Data Register (both buffer and shift register are empty).
  - Receiver mode: If RxNE=1 and BTF=1: the interface holds the clock line low after reception to wait for the microcontroller to read SR1 and then read the byte in the Data Register (both buffer and shift register are full).
- If clock stretching is disabled in Slave mode:
  - Overrun Error in case of RxNE=1 and no read of DR has been done before the next byte is received. The last received byte is lost.
  - Underrun Error in case TxE=1 and no write into DR has been done before the next byte must be transmitted. The same byte will be sent again.
  - Write Collision not managed.

## 25.3.6 SMBus

### Introduction

The System Management Bus (SMBus) is a two-wire interface through which various devices can communicate with each other and with the rest of the system. It is based on I<sup>2</sup>C principles of operation. SMBus provides a control bus for system and power management related tasks. A system may use SMBus to pass messages to and from devices instead of toggling individual control lines.

The System Management Bus Specification refers to three types of devices. A *slave* is a device that is receiving or responding to a command. A *master* is a device that issues commands, generates the clocks, and terminates the transfer. A *host* is a specialized master that provides the main interface to the system's CPU. A host must be a master-slave and must support the SMBus host notify protocol. Only one host is allowed in a system.

### Similarities between SMBus and I<sup>2</sup>C

- 2 wire bus protocol (1 Clk, 1 Data) + SMBus Alert line optional
- Master-slave communication, Master provides clock
- Multi master capability
- SMBus data format similar to I<sup>2</sup>C 7-bit addressing format ([Figure 268](#)).

### Differences between SMBus and I<sup>2</sup>C

The following table describes the differences between SMBus and I<sup>2</sup>C.

**Table 185. SMBus vs. I<sup>2</sup>C**

SMBus	I <sup>2</sup> C
Max. speed 100 kHz	Max. speed 400 kHz
Min. clock speed 10 kHz	No minimum clock speed
35 ms clock low timeout	No timeout
Logic levels are fixed	Logic levels are V <sub>DD</sub> dependent
Different address types (reserved, dynamic etc.)	7-bit, 10-bit and general call slave address types
Different bus protocols (quick command, process call etc.)	No bus protocols

### SMBus application usage

With System Management Bus, a device can provide manufacturer information, tell the system what its model/part number is, save its state for a suspend event, report different types of errors, accept control parameters, and return its status. SMBus provides a control bus for system and power management related tasks.

### Device identification

Any device that exists on the System Management Bus as a slave has a unique address called the Slave Address. For the list of reserved slave addresses, refer to the SMBus specification ver. 2.0 (<http://smbus.org/specs/>).

## Bus protocols

The SMBus specification supports up to 9 bus protocols. For more details of these protocols and SMBus address types, refer to SMBus specification ver. 2.0 (<http://smbus.org/specs/>). These protocols should be implemented by the user software.

### Address resolution protocol (ARP)

SMBus slave address conflicts can be resolved by dynamically assigning a new unique address to each slave device. The Address Resolution Protocol (ARP) has the following attributes:

- Address assignment uses the standard SMBus physical layer arbitration mechanism
- Assigned addresses remain constant while device power is applied; address retention through device power loss is also allowed
- No additional SMBus packet overhead is incurred after address assignment. (i.e. subsequent accesses to assigned slave addresses have the same overhead as accesses to fixed address devices.)
- Any SMBus master can enumerate the bus

### Unique device identifier (UDID)

In order to provide a mechanism to isolate each device for the purpose of address assignment, each device must implement a unique device identifier (UDID).

For the details on 128 bit UDID and more information on ARP, refer to SMBus specification ver. 2.0 (<http://smbus.org/specs/>).

### SMBus alert mode

SMBus Alert is an optional signal with an interrupt line for devices that want to trade their ability to master for a pin. SMBA is a wired-AND signal just as the SCL and SDA signals are. SMBA is used in conjunction with the SMBus General Call Address. Messages invoked with the SMBus are 2 bytes long.

A slave-only device can signal the host through SMBA that it wants to talk by setting ALERT bit in I2C\_CR1 register. The host processes the interrupt and simultaneously accesses all SMBA devices through the *Alert Response Address* (known as ARA having a value 0001 100X). Only the device(s) which pulled SMBA low will acknowledge the Alert Response Address. This status is identified using SMBALERT Status flag in I2C\_SR1 register. The host performs a modified Receive Byte operation. The 7 bit device address provided by the slave transmit device is placed in the 7 most significant bits of the byte. The eighth bit can be a zero or one.

If more than one device pulls SMBA low, the highest priority (lowest address) device will win communication rights via standard arbitration during the slave address transfer. After acknowledging the slave address the device must disengage its SMBA pull-down. If the host still sees SMBA low when the message transfer is complete, it knows to read the ARA again.

A host which does not implement the SMBA signal may periodically access the ARA.

For more details on SMBus Alert mode, refer to SMBus specification ver. 2.0 (<http://smbus.org/specs/>).

### Timeout error

There are differences in the timing specifications between I<sup>2</sup>C and SMBus. SMBus defines a clock low timeout, TIMEOUT of 35 ms. Also SMBus specifies TLOW: SEXT as the cumulative clock low extend time for a slave device. SMBus specifies TLOW: MEXT as the cumulative clock low extend time for a master device. For more details on these timeouts, refer to SMBus specification ver. 2.0 (<http://smbus.org/specs/>).

The status flag Timeout or Tlow Error in I2C\_SR1 shows the status of this feature.

### How to use the interface in SMBus mode

To switch from I<sup>2</sup>C mode to SMBus mode, the following sequence should be performed.

- Set the SMBus bit in the I2C\_CR1 register
- Configure the SMBTYPE and ENARP bits in the I2C\_CR1 register as required for the application

If you want to configure the device as a master, follow the Start condition generation procedure in [Section 25.3.3: I2C master mode](#). Otherwise, follow the sequence in [Section 25.3.2: I2C slave mode](#).

The application has to control the various SMBus protocols by software.

- SMB Device Default Address acknowledged if ENARP=1 and SMBTYPE=0
- SMB Host Header acknowledged if ENARP=1 and SMBTYPE=1
- SMB Alert Response Address acknowledged if SMBALERT=1

## 25.3.7 DMA requests

DMA requests (when enabled) are generated only for data transfer. DMA requests are generated by Data Register becoming empty in transmission and Data Register becoming full in reception. The DMA request must be served before the end of the current byte transfer. When the number of data transfers which has been programmed for the corresponding DMA channel is reached, the DMA controller sends an End of Transfer EOT signal to the I<sup>2</sup>C interface and generates a Transfer Complete interrupt if enabled:

- Master transmitter: In the interrupt routine after the EOT interrupt, disable DMA requests then wait for a BTF event before programming the Stop condition.
- Master receiver: when the number of bytes to be received is equal to or greater than two, the DMA controller sends a hardware signal, EOT\_1, corresponding to the last but one data byte (number\_of\_bytes – 1). If, in the I2C\_CR2 register, the LAST bit is set, I<sup>2</sup>C automatically sends a NACK after the next byte following EOT\_1. The user can generate a Stop condition in the DMA Transfer Complete interrupt routine if enabled.

### Transmission using DMA

DMA mode can be enabled for transmission by setting the DMAEN bit in the I2C\_CR2 register. Data will be loaded from a Memory area configured using the DMA peripheral (refer to the DMA specification) to the I2C\_DR register whenever the TxE bit is set. To map a DMA channel for I<sup>2</sup>C transmission, perform the following sequence. Here x is the channel number.

1. Set the I2C\_DR register address in the DMA\_CPARx register. The data will be moved to this address from the memory after each TxE event.
2. Set the memory address in the DMA\_CMARx register. The data will be loaded into I2C\_DR from this memory after each TxE event.

3. Configure the total number of bytes to be transferred in the DMA\_CNDTRx register. After each TxE event, this value will be decremented.
4. Configure the channel priority using the PL[0:1] bits in the DMA\_CCRx register
5. Set the DIR bit and, in the DMA\_CCRx register, configure interrupts after half transfer or full transfer depending on application requirements.
6. Activate the channel by setting the EN bit in the DMA\_CCRx register.

When the number of data transfers which has been programmed in the DMA Controller registers is reached, the DMA controller sends an End of Transfer EOT/ EOT\_1 signal to the I<sup>2</sup>C interface and the DMA generates an interrupt, if enabled, on the DMA channel interrupt vector.

*Note:* Do not enable the ITBUFEN bit in the I2C\_CR2 register if DMA is used for transmission.

### Reception using DMA

DMA mode can be enabled for reception by setting the DMAEN bit in the I2C\_CR2 register. Data will be loaded from the I2C\_DR register to a Memory area configured using the DMA peripheral (refer to the DMA specification) whenever a data byte is received. To map a DMA channel for I<sup>2</sup>C reception, perform the following sequence. Here x is the channel number.

1. Set the I2C\_DR register address in DMA\_CPARx register. The data will be moved from this address to the memory after each RxNE event.
2. Set the memory address in the DMA\_CMARx register. The data will be loaded from the I2C\_DR register to this memory area after each RxNE event.
3. Configure the total number of bytes to be transferred in the DMA\_CNDTRx register. After each RxNE event, this value will be decremented.
4. Configure the channel priority using the PL[0:1] bits in the DMA\_CCRx register
5. Reset the DIR bit and configure interrupts in the DMA\_CCRx register after half transfer or full transfer depending on application requirements.
6. Activate the channel by setting the EN bit in the DMA\_CCRx register.

When the number of data transfers which has been programmed in the DMA Controller registers is reached, the DMA controller sends an End of Transfer EOT/ EOT\_1 signal to the I<sup>2</sup>C interface and DMA generates an interrupt, if enabled, on the DMA channel interrupt vector.

*Note:* Do not enable the ITBUFEN bit in the I2C\_CR2 register if DMA is used for reception.

### 25.3.8 Packet error checking

A PEC calculator has been implemented to improve the reliability of communication. The PEC is calculated by using the  $C(x) = x^8 + x^2 + x + 1$  CRC-8 polynomial serially on each bit.

- PEC calculation is enabled by setting the ENPEC bit in the I2C\_CR1 register. PEC is a CRC-8 calculated on all message bytes including addresses and R/W bits.
  - In transmission: set the PEC transfer bit in the I2C\_CR1 register after the TxE event corresponding to the last byte. The PEC will be transferred after the last transmitted byte.
  - In reception: set the PEC bit in the I2C\_CR1 register after the RxNE event corresponding to the last byte so that the receiver sends a NACK if the next received byte is not equal to the internally calculated PEC. In case of Master-

Receiver, a NACK must follow the PEC whatever the check result. PEC must be set before the ACK pulse of the current byte reception.

- A PECERR error flag/interrupt is also available in the I2C\_SR1 register.
- If DMA and PEC calculation are both enabled:-
  - In transmission: when the I<sup>2</sup>C interface receives an EOT signal from the DMA controller, it automatically sends a PEC after the last byte.
  - In reception: when the I<sup>2</sup>C interface receives an EOT\_1 signal from the DMA controller, it will automatically consider the next byte as a PEC and will check it. A DMA request is generated after PEC reception.
- To allow intermediate PEC transfers, a control bit is available in the I2C\_CR2 register (LAST bit) to determine if it is really the last DMA transfer or not. If it is the last DMA request for a master receiver, a NACK is automatically sent after the last received byte.
- PEC calculation is corrupted by an arbitration loss.

## 25.4 I<sup>2</sup>C interrupts

The table below gives the list of I<sup>2</sup>C interrupt requests.

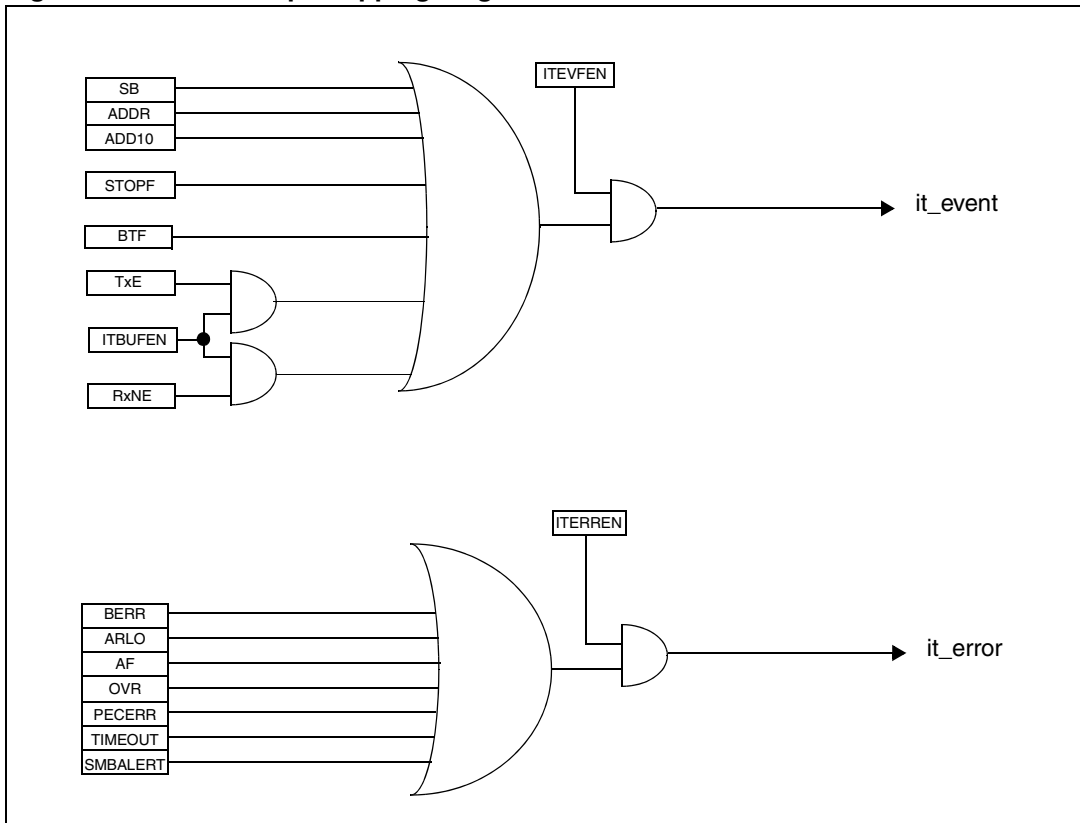
**Table 186. I<sup>2</sup>C Interrupt requests**

Interrupt event	Event flag	Enable Control bit
Start bit sent (Master)	SB	ITEVFEN
Address sent (Master) or Address matched (Slave)	ADDR	
10-bit header sent (Master)	ADD10	
Stop received (Slave)	STOPF	
Data byte transfer finished	BTF	
Receive buffer not empty	RxNE	ITEVFEN and ITBUFEN
Transmit buffer empty	TxE	
Bus error	BERR	ITERREN
Arbitration loss (Master)	ARLO	
Acknowledge failure	AF	
Overrun/Underrun	OVR	
PEC error	PECERR	
Timeout/Tlow error	TIMEOUT	
SMBus Alert	SMBALERT	

- Note:*
- 1 *SB, ADDR, ADD10, STOPF, BTF, RxNE and TxE are logically ORed on the same interrupt channel.*
  - 2 *BERR, ARLO, AF, OVR, PECERR, TIMEOUT and SMBALERT are logically ORed on the same interrupt channel.*



Figure 277. I<sup>2</sup>C interrupt mapping diagram



## 25.5 I<sup>2</sup>C debug mode

When the microcontroller enters the debug mode (Cortex-M3 core halted), the SMBUS timeout either continues to work normally or stops, depending on the DBG\_I2Cx\_SMBUS\_TIMEOUT configuration bits in the DBG module. For more details, refer to [Section 30.16.2: Debug support for timers, watchdog, bxCAN and I2C on page 1047](#).

## 25.6 I<sup>2</sup>C registers

Refer to [Section 1.1 on page 40](#) for a list of abbreviations used in register descriptions.

The peripheral registers can be accessed by half-words (16-bit) or words (32-bit).

### 25.6.1 Control register 1 (I2C\_CR1)

Address offset: 0x00

Reset value: 0x0000

15	14	13	12	11	10	9	8	7	6	5	4	3	2	1	0
SWRST	Res.	ALERT	PEC	POS	ACK	STOP	START	NO STRETCH	ENG	ENPEC	ENARP	SMB TYPE	Res.	SMBUS	PE
rw		rw	rw	rw	rw	rw	rw	rw	rw	rw	rw	rw		rw	rw

Bit 15 **SWRST**: Software reset

When set, the I2C is under reset state. Before resetting this bit, make sure the I2C lines are released and the bus is free.

0: I<sup>2</sup>C Peripheral not under reset

1: I<sup>2</sup>C Peripheral under reset state

*Note: This bit can be used in case the BUSY bit is set to '1 when no stop condition has been detected on the bus.*

Bit 14 Reserved, forced by hardware to 0.

Bit 13 **ALERT**: SMBus alert

This bit is set and cleared by software, and cleared by hardware when PE=0.

0: Releases SMBA pin high. Alert Response Address Header followed by NACK.

1: Drives SMBA pin low. Alert Response Address Header followed by ACK.

Bit 12 **PEC**: Packet error checking

This bit is set and cleared by software, and cleared by hardware when PEC is transferred or by a START or Stop condition or when PE=0.

0: No PEC transfer

1: PEC transfer (in Tx or Rx mode)

*Note: PEC calculation is corrupted by an arbitration loss.*

**Bit 11 POS:** Acknowledge/PEC Position (for data reception)

This bit is set and cleared by software and cleared by hardware when PE=0.

0: ACK bit controls the (N)ACK of the current byte being received in the shift register. The PEC bit indicates that current byte in shift register is a PEC.

1: ACK bit controls the (N)ACK of the next byte which will be received in the shift register. The PEC bit indicates that the next byte in the shift register is a PEC

*Note: The POS bit is used when the procedure for reception of 2 bytes (see [Method 2: transfer sequence diagram for master receiver when N=2](#)) is followed. It must be configured before data reception starts. In this case, to NACK the 2nd byte, the ACK bit must be cleared just after ADDR is cleared.*

**Bit 10 ACK:** Acknowledge enable

This bit is set and cleared by software and cleared by hardware when PE=0.

0: No acknowledge returned

1: Acknowledge returned after a byte is received (matched address or data)

**Bit 9 STOP:** Stop generation

The bit is set and cleared by software, cleared by hardware when a Stop condition is detected, set by hardware when a timeout error is detected.

In Master Mode:

0: No Stop generation.

1: Stop generation after the current byte transfer or after the current Start condition is sent.

In Slave mode:

0: No Stop generation.

1: Release the SCL and SDA lines after the current byte transfer.

*Note: When the STOP, START or PEC bit is set, the software must not perform any write access to I2C\_CR1 before this bit is cleared by hardware. Otherwise there is a risk of setting a second STOP, START or PEC request.*

**Bit 8 START:** Start generation

This bit is set and cleared by software and cleared by hardware when start is sent or PE=0.

In Master Mode:

0: No Start generation

1: Repeated start generation

In Slave mode:

0: No Start generation

1: Start generation when the bus is free

**Bit 7 NOSTRETCH:** Clock stretching disable (Slave mode)

This bit is used to disable clock stretching in slave mode when ADDR or BTF flag is set, until it is reset by software.

0: Clock stretching enabled

1: Clock stretching disabled

**Bit 6 ENGCG:** General call enable

0: General call disabled. Address 00h is NACKed.

1: General call enabled. Address 00h is ACKed.

**Bit 5 ENPEC:** PEC enable

0: PEC calculation disabled

1: PEC calculation enabled

- Bit 4 **ENARP**: ARP enable
  - 0: ARP disable
  - 1: ARP enable
  - SMBus Device default address recognized if SMBTYPE=0
  - SMBus Host address recognized if SMBTYPE=1
- Bit 3 **SMBTYPE**: SMBus type
  - 0: SMBus Device
  - 1: SMBus Host
- Bit 2 Reserved, forced by hardware to 0.
- Bit 1 **SMBUS**: SMBus mode
  - 0: I<sup>2</sup>C mode
  - 1: SMBus mode
- Bit 0 **PE**: Peripheral enable
  - 0: Peripheral disable
  - 1: Peripheral enable: the corresponding IOs are selected as alternate functions depending on SMBus bit.

*Note: If this bit is reset while a communication is on going, the peripheral is disabled at the end of the current communication, when back to IDLE state.  
All bit resets due to PE=0 occur at the end of the communication.  
In master mode, this bit must not be reset before the end of the communication.*

### 25.6.2 Control register 2 (I2C\_CR2)

Address offset: 0x04  
Reset value: 0x0000

15	14	13	12	11	10	9	8	7	6	5	4	3	2	1	0	
Reserved			LAST	DMA EN	ITBUF EN	ITEVT EN	ITERR EN	Reserved			FREQ[5:0]					
			rw	rw	rw	rw	rw				rw	rw	rw	rw	rw	rw

- Bits 15:13 Reserved, forced by hardware to 0.
- Bit 12 **LAST**: DMA last transfer
  - 0: Next DMA EOT is not the last transfer
  - 1: Next DMA EOT is the last transfer

*Note: This bit is used in master receiver mode to permit the generation of a NACK on the last received data.*
- Bit 11 **DMAEN**: DMA requests enable
  - 0: DMA requests disabled
  - 1: DMA request enabled when TxE=1 or RxNE =1
- Bit 10 **ITBUFEN**: Buffer interrupt enable
  - 0: TxE = 1 or RxNE = 1 does not generate any interrupt.
  - 1:TxE = 1 or RxNE = 1 generates Event Interrupt (whatever the state of DMAEN)

Bit 9 **ITEVTEN**: Event interrupt enable

- 0: Event interrupt disabled
- 1: Event interrupt enabled

This interrupt is generated when:

- SB = 1 (Master)
- ADDR = 1 (Master/Slave)
- ADD10= 1 (Master)
- STOPF = 1 (Slave)
- BTF = 1 with no TxE or RxNE event
- TxE event to 1 if ITBUFEN = 1
- RxNE event to 1 if ITBUFEN = 1

Bit 8 **ITERREN**: Error interrupt enable

- 0: Error interrupt disabled
- 1: Error interrupt enabled

This interrupt is generated when:

- BERR = 1
- ARLO = 1
- AF = 1
- OVR = 1
- PECERR = 1
- TIMEOUT = 1
- SMBALERT = 1

Bits 7:6 Reserved, forced by hardware to 0.

Bits 5:0 **FREQ[5:0]**: Peripheral clock frequency

The peripheral clock frequency must be configured using the input APB clock frequency (I2C peripheral connected to APB). The minimum allowed frequency is 2 MHz, the maximum frequency is limited by the maximum APB frequency (36 MHz) and an intrinsic limitation of 46 MHz.

0b000000: Not allowed

0b000001: Not allowed

0b000010: 2 MHz

...

0b100100: 36 MHz

Higher than 0b100100: Not allowed

### 25.6.3 Own address register 1 (I2C\_OAR1)

Address offset: 0x08

Reset value: 0x0000

15	14	13	12	11	10	9	8	7	6	5	4	3	2	1	0
ADD MODE	Reserved					ADD[9:8]		ADD[7:1]							ADD0
rw						rw	rw	rw	rw	rw	rw	rw	rw	rw	rw

Bit 15 **ADDMODE** Addressing mode (slave mode)

- 0: 7-bit slave address (10-bit address not acknowledged)
- 1: 10-bit slave address (7-bit address not acknowledged)

Bit 14 Should always be kept at 1 by software.

- Bits 13:10 Reserved, forced by hardware to 0.
- Bits 9:8 **ADD[9:8]**: Interface address
  - 7-bit addressing mode: don't care
  - 10-bit addressing mode: bits9:8 of address
- Bits 7:1 **ADD[7:1]**: Interface address
  - bits 7:1 of address
- Bit 0 **ADD0**: Interface address
  - 7-bit addressing mode: don't care
  - 10-bit addressing mode: bit 0 of address

### 25.6.4 Own address register 2 (I2C\_OAR2)

Address offset: 0x0C  
 Reset value: 0x0000

	15	14	13	12	11	10	9	8	7	6	5	4	3	2	1	0
Reserved									ADD2[7:1]							ENDUAL
									rw	rw	rw	rw	rw	rw	rw	rw

- Bits 15:8 Reserved, forced by hardware to 0.
- Bits 7:1 **ADD2[7:1]**: Interface address
  - bits 7:1 of address in dual addressing mode
- Bit 0 **ENDUAL**: Dual addressing mode enable
  - 0: Only OAR1 is recognized in 7-bit addressing mode
  - 1: Both OAR1 and OAR2 are recognized in 7-bit addressing mode

### 25.6.5 Data register (I2C\_DR)

Address offset: 0x10  
 Reset value: 0x0000

	15	14	13	12	11	10	9	8	7	6	5	4	3	2	1	0
Reserved									DR[7:0]							
									rw	rw	rw	rw	rw	rw	rw	rw

- Bits 15:8 Reserved, forced by hardware to 0.
- Bits 7:0 **DR[7:0]** 8-bit data register
  - Byte received or to be transmitted to the bus.
    - Transmitter mode: Byte transmission starts automatically when a byte is written in the DR register. A continuous transmit stream can be maintained if the next data to be transmitted is put in DR once the transmission is started (TxE=1)
    - Receiver mode: Received byte is copied into DR (RxNE=1). A continuous transmit stream can be maintained if DR is read before the next data byte is received (RxNE=1).
  - Note: In slave mode, the address is not copied into DR.*
  - Note: Write collision is not managed (DR can be written if TxE=0).*
  - Note: If an ARLO event occurs on ACK pulse, the received byte is not copied into DR and so cannot be read.*

### 25.6.6 Status register 1 (I2C\_SR1)

Address offset: 0x14

Reset value: 0x0000

15	14	13	12	11	10	9	8	7	6	5	4	3	2	1	0
SMB ALERT	TIME OUT	Res.	PEC ERR	OVR	AF	ARLO	BERR	TxE	RxNE	Res.	STOPF	ADD10	BTF	ADDR	SB
rc_w0	rc_w0		rc_w0	rc_w0	rc_w0	rc_w0	rc_w0	r	r		r	r	r	r	r

Bit 15 **SMBALERT**: SMBus alert

In SMBus host mode:

0: no SMBALERT

1: SMBALERT event occurred on pin

In SMBus slave mode:

0: no SMBALERT response address header

1: SMBALERT response address header to SMBALERT LOW received

– Cleared by software writing 0, or by hardware when PE=0.

Bit 14 **TIMEOUT**: Timeout or Tlow error

0: No timeout error

1: SCL remained LOW for 25 ms (Timeout)

or

Master cumulative clock low extend time more than 10 ms (Tlow:mext)

or

Slave cumulative clock low extend time more than 25 ms (Tlow:sext)

– When set in slave mode: slave resets the communication and lines are released by hardware

– When set in master mode: Stop condition sent by hardware

– Cleared by software writing 0, or by hardware when PE=0.

*Note: This functionality is available only in SMBus mode.*

Bit 13 Reserved, forced by hardware to 0.

Bit 12 **PECERR**: PEC Error in reception

0: no PEC error: receiver returns ACK after PEC reception (if ACK=1)

1: PEC error: receiver returns NACK after PEC reception (whatever ACK)

–Cleared by software writing 0, or by hardware when PE=0.

Bit 11 **OVR**: Overrun/Underrun

0: No overrun/underrun

1: Overrun or underrun

–Set by hardware in slave mode when NOSTRETCH=1 and:

–In reception when a new byte is received (including ACK pulse) and the DR register has not been read yet. New received byte is lost.

–In transmission when a new byte should be sent and the DR register has not been written yet. The same byte is sent twice.

–Cleared by software writing 0, or by hardware when PE=0.

*Note: If the DR write occurs very close to SCL rising edge, the sent data is unspecified and a hold timing error occurs*

Bit 10 **AF**: Acknowledge failure

0: No acknowledge failure

1: Acknowledge failure

–Set by hardware when no acknowledge is returned.

–Cleared by software writing 0, or by hardware when PE=0.

- Bit 9 **ARLO**: Arbitration lost (master mode)
- 0: No Arbitration Lost detected
  - 1: Arbitration Lost detected
- Set by hardware when the interface loses the arbitration of the bus to another master  
–Cleared by software writing 0, or by hardware when PE=0.
- After an ARLO event the interface switches back automatically to Slave mode (M/SL=0).
- Note: In SMBUS, the arbitration on the data in slave mode occurs only during the data phase, or the acknowledge transmission (not on the address acknowledge).*
- Bit 8 **BERR**: Bus error
- 0: No misplaced Start or Stop condition
  - 1: Misplaced Start or Stop condition
- Set by hardware when the interface detects a misplaced Start or Stop condition  
–Cleared by software writing 0, or by hardware when PE=0.
- Bit 7 **TxE**: Data register empty (transmitters)
- 0: Data register not empty
  - 1: Data register empty
- Set when DR is empty in transmission. TxE is not set during address phase.  
–Cleared by software writing to the DR register or by hardware after a start or a stop condition or when PE=0.
- TxE is not set if either a NACK is received, or if next byte to be transmitted is PEC (PEC=1)
- Note: TxE is not cleared by writing the first data being transmitted, or by writing data when BTF is set, as in both cases the data register is still empty.*
- Bit 6 **RxNE**: Data register not empty (receivers)
- 0: Data register empty
  - 1: Data register not empty
- Set when data register is not empty in receiver mode. RxNE is not set during address phase.  
–Cleared by software reading or writing the DR register or by hardware when PE=0.
- RxNE is not set in case of ARLO event.
- Note: RxNE is not cleared by reading data when BTF is set, as the data register is still full.*
- Bit 5 Reserved, forced by hardware to 0.
- Bit 4 **STOPF**: Stop detection (slave mode)
- 0: No Stop condition detected
  - 1: Stop condition detected
- Set by hardware when a Stop condition is detected on the bus by the slave after an acknowledge (if ACK=1).  
–Cleared by software reading the SR1 register followed by a write in the CR1 register, or by hardware when PE=0
- Note: The STOPF bit is not set after a NACK reception*
- Bit 3 **ADD10**: 10-bit header sent (Master mode)
- 0: No ADD10 event occurred.
  - 1: Master has sent first address byte (header).
- Set by hardware when the master has sent the first byte in 10-bit address mode.  
–Cleared by software reading the SR1 register followed by a write in the DR register of the second address byte, or by hardware when PE=0.
- Note: ADD10 bit is not set after a NACK reception*



**Bit 2 BTF:** Byte transfer finished

0: Data byte transfer not done

1: Data byte transfer succeeded

–Set by hardware when NOSTRETCH=0 and:

–In reception when a new byte is received (including ACK pulse) and DR has not been read yet (RxNE=1).

–In transmission when a new byte should be sent and DR has not been written yet (TxE=1).

–Cleared by software reading SR1 followed by either a read or write in the DR register or by hardware after a start or a stop condition in transmission or when PE=0.

*Note: The BTF bit is not set after a NACK reception**The BTF bit is not set if next byte to be transmitted is the PEC (TRA=1 in I2C\_SR2 register and PEC=1 in I2C\_CR1 register)***Bit 1 ADDR:** Address sent (master mode)/matched (slave mode)

This bit is cleared by software reading SR1 register followed reading SR2, or by hardware when PE=0.

**Address matched (Slave)**

0: Address mismatched or not received.

1: Received address matched.

–Set by hardware as soon as the received slave address matched with the OAR registers content or a general call or a SMBus Device Default Address or SMBus Host or SMBus Alert is recognized. (when enabled depending on configuration).

**Address sent (Master)**

0: No end of address transmission

1: End of address transmission

–For 10-bit addressing, the bit is set after the ACK of the 2nd byte.

–For 7-bit addressing, the bit is set after the ACK of the byte.

*Note: ADDR is not set after a NACK reception***Bit 0 SB:** Start bit (Master mode)

0: No Start condition

1: Start condition generated.

–Set when a Start condition generated.

–Cleared by software by reading the SR1 register followed by writing the DR register, or by hardware when PE=0

### 25.6.7 Status register 2 (I2C\_SR2)

Address offset: 0x18

Reset value:0x0000

15	14	13	12	11	10	9	8	7	6	5	4	3	2	1	0
PEC[7:0]								DUALF	SMB HOST	SMBDE FAULT	GEN CALL	Res.	TRA	BUSY	MSL
r	r	r	r	r	r	r	r	r	r	r	r		r	r	r

Bits 15:8 **PEC[7:0]** Packet error checking register

This register contains the internal PEC when ENPEC=1.

Bit 7 **DUALF**: Dual flag (Slave mode)

0: Received address matched with OAR1

1: Received address matched with OAR2

–Cleared by hardware after a Stop condition or repeated Start condition, or when PE=0.

Bit 6 **SMBHOST**: SMBus host header (Slave mode)

0: No SMBus Host address

1: SMBus Host address received when SMBTYPE=1 and ENARP=1.

–Cleared by hardware after a Stop condition or repeated Start condition, or when PE=0.

Bit 5 **SMBDEFAULT**: SMBus device default address (Slave mode)

0: No SMBus Device Default address

1: SMBus Device Default address received when ENARP=1

–Cleared by hardware after a Stop condition or repeated Start condition, or when PE=0.

Bit 4 **GENCALL**: General call address (Slave mode)

0: No General Call

1: General Call Address received when ENGC=1

–Cleared by hardware after a Stop condition or repeated Start condition, or when PE=0.

Bit 3 Reserved, forced by hardware to 0.

Bit 2 **TRA**: Transmitter/receiver

0: Data bytes received

1: Data bytes transmitted

This bit is set depending on the R/W bit of the address byte, at the end of total address phase.

It is also cleared by hardware after detection of Stop condition (STOPF=1), repeated Start condition, loss of bus arbitration (ARLO=1), or when PE=0.

Bit 1 **BUSY**: Bus busy

0: No communication on the bus

1: Communication ongoing on the bus

–Set by hardware on detection of SDA or SCL low

–cleared by hardware on detection of a Stop condition.

It indicates a communication in progress on the bus. This information is still updated when the interface is disabled (PE=0).

Bit 0 **MSL**: Master/slave

0: Slave Mode  
1: Master Mode

–Set by hardware as soon as the interface is in Master mode (SB=1).

–Cleared by hardware after detecting a Stop condition on the bus or a loss of arbitration (ARLO=1), or by hardware when PE=0.

## 25.6.8 Clock control register (I2C\_CCR)

Address offset: 0x1C

Reset value: 0x0000

- Note: 1  $F_{PCLK1}$  is the multiple of 10 MHz required to generate the Fast clock at 400 kHz.  
2 The CCR register must be configured only when the I2C is disabled (PE = 0).

15	14	13	12	11	10	9	8	7	6	5	4	3	2	1	0	
F/S	DUTY	Reserved			CCR[11:0]											
rw	rw				rw	rw	rw	rw	rw	rw	rw	rw	rw	rw	rw	rw

Bit 15 **F/S**: I2C master mode selection

0: Standard Mode I2C  
1: Fast Mode I2C

Bit 14 **DUTY**: Fast mode duty cycle

0: Fast Mode  $t_{low}/t_{high} = 2$   
1: Fast Mode  $t_{low}/t_{high} = 16/9$  (see CCR)

Bits 13:12 Reserved, forced by hardware to 0.

Bits 11:0 **CCR[11:0]**: Clock control register in Fast/Standard mode (Master mode)

Controls the SCL clock in master mode.

Standard mode or SMBus:

$$T_{high} = CCR * T_{PCLK1}$$

$$T_{low} = CCR * T_{PCLK1}$$

Fast mode:

If DUTY = 0:

$$T_{high} = CCR * T_{PCLK1}$$

$$T_{low} = 2 * CCR * T_{PCLK1}$$

If DUTY = 1: (to reach 400 kHz)

$$T_{high} = 9 * CCR * T_{PCLK1}$$

$$T_{low} = 16 * CCR * T_{PCLK1}$$

For instance: in standard mode, to generate a 100 kHz SCL frequency:

If FREQR = 08,  $T_{PCLK1} = 125$  ns so CCR must be programmed with 0x28

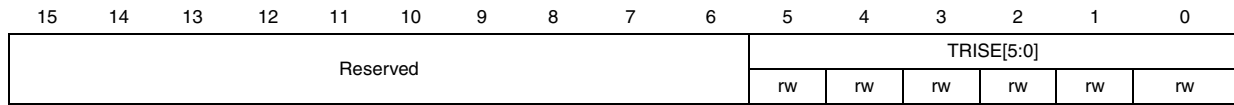
(0x28  $\Leftrightarrow$  40d x 125 ns = 5000 ns.)

- Note: 1. The minimum allowed value is 0x04, except in FAST DUTY mode where the minimum allowed value is 0x01  
2.  $t_{high} = t_{r(SCL)} + t_{w(SCLH)}$ . See device datasheet for the definitions of parameters  
3.  $t_{low} = t_{f(SCL)} + t_{w(SCLL)}$ . See device datasheet for the definitions of parameters  
4. These timings are without filters.  
5. The CCR register must be configured only when the I<sup>2</sup>C is disabled (PE = 0).

### 25.6.9 TRISE register (I2C\_TRISE)

Address offset: 0x20

Reset value: 0x0002



Bits 15:6 Reserved, forced by hardware to 0.

Bits 5:0 **TRISE[5:0]**: Maximum rise time in Fast/Standard mode (Master mode)

These bits must be programmed with the maximum SCL rise time given in the I<sup>2</sup>C bus specification, incremented by 1.

For instance: in standard mode, the maximum allowed SCL rise time is 1000 ns.

If, in the I2C\_CR2 register, the value of **FREQ[5:0]** bits is equal to 0x08 and  $T_{PCLK1} = 125$  ns therefore the **TRISE[5:0]** bits must be programmed with 09h.

$(1000 \text{ ns} / 125 \text{ ns} = 8 + 1)$

The filter value can also be added to **TRISE[5:0]**.

If the result is not an integer, **TRISE[5:0]** must be programmed with the integer part, in order to respect the  $t_{HIGH}$  parameter.

*Note: **TRISE[5:0]** must be configured only when the I2C is disabled ( $PE = 0$ ).*

### 25.6.10 I<sup>2</sup>C register map

The table below provides the I<sup>2</sup>C register map and reset values.

**Table 187. I<sup>2</sup>C register map and reset values**

Offset	Register	31	30	29	28	27	26	25	24	23	22	21	20	19	18	17	16	15	14	13	12	11	10	9	8	7	6	5	4	3	2	1	0															
0x00	I2C_CR1 Reset value	Reserved														0	Reserved	0	ALERT	0	PEC	0	POS	0	ACK	0	STOP	0	START	0	NOSTRETCH	0	ENGC	0	ENPEC	0	ENARP	0	SMBTYPE	0	Reserved	0	SMBUS	0	PE	0		
0x04	I2C_CR2 Reset value	Reserved														0	LAST	0	DMAEN	0	ITBUFEN	0	ITEVTEN	0	ITERREN	0	Reserved	FREQ[5:0]					0	0	0	0	0	0	0	0								
0x08	I2C_OAR1 Reset value	Reserved														0	ADDMODE	0	Reserved	Reserved			ADD[9:8]		ADD[7:1]					ADD0		0																
0x0C	I2C_OAR2 Reset value	Reserved														ADD2[7:1]					ENDUAL		0																									
0x10	I2C_DR Reset value	Reserved														DR[7:0]					0	0	0	0	0	0	0	0																				
0x14	I2C_SR1 Reset value	Reserved														0	SMBALERT	0	TIMEOUT	0	Reserved	0	PECERR	0	OVR	0	AF	0	ARLO	0	BERR	0	TXE	0	RxNE	0	Reserved	0	STOPF	0	ADD10	0	BTF	0	ADDR	0	SB	0
0x18	I2C_SR2 Reset value	Reserved														PEC[7:0]					0	DUALF	0	SMBHOST	0	SMBDEFAULT	0	GENCALL	0	Reserved	0	TRA	0	BUSY	0	MSL	0											
0x1C	I2C_CCR Reset value	Reserved														0	F/S	0	DUTY	0	Reserved	CCR[11:0]											0	0	0	0	0	0	0	0	0	0						
0x20	I2C_TRISE Reset value	Reserved														TRISE[5:0]					0	0	0	0	0	1	0																					

Refer to *Register boundary addresses* table.

## 26 Universal synchronous asynchronous receiver transmitter (USART)

**Low-density devices** are STM32F101xx, STM32F102xx and STM32F103xx microcontrollers where the Flash memory density ranges between 16 and 32 Kbytes.

**Medium-density devices** are STM32F101xx, STM32F102xx and STM32F103xx microcontrollers where the Flash memory density ranges between 64 and 128 Kbytes.

**High-density devices** are STM32F101xx and STM32F103xx microcontrollers where the Flash memory density ranges between 256 and 512 Kbytes.

**XL-density devices** are STM32F101xx and STM32F103xx microcontrollers where the Flash memory density ranges between 768 Kbytes and 1 Mbyte.

**Connectivity line devices** are STM32F105xx and STM32F107xx microcontrollers.

This Section applies to the whole STM32F10xxx family, unless otherwise specified.

### 26.1 USART introduction

The universal synchronous asynchronous receiver transmitter (USART) offers a flexible means of full-duplex data exchange with external equipment requiring an industry standard NRZ asynchronous serial data format. The USART offers a very wide range of baud rates using a fractional baud rate generator.

It supports synchronous one-way communication and half-duplex single wire communication. It also supports the LIN (local interconnection network), Smartcard Protocol and IrDA (infrared data association) SIR ENDEC specifications, and modem operations (CTS/RTS). It allows multiprocessor communication.

High speed data communication is possible by using the DMA for multibuffer configuration.

## 26.2 USART main features

- Full duplex, asynchronous communications
- NRZ standard format (Mark/Space)
- Fractional baud rate generator systems
  - A common programmable transmit and receive baud rates up to 4.5 MBits/s
- Programmable data word length (8 or 9 bits)
- Configurable stop bits - support for 1 or 2 stop bits
- LIN Master Synchronous Break send capability and LIN slave break detection capability
  - 13-bit break generation and 10/11 bit break detection when USART is hardware configured for LIN
- Transmitter clock output for synchronous transmission
- IrDA SIR Encoder Decoder
  - Support for 3/16 bit duration for normal mode
- Smartcard Emulation Capability
  - The Smartcard interface supports the asynchronous protocol Smartcards as defined in ISO 7816-3 standards
  - 0.5, 1.5 Stop Bits for Smartcard operation
- Single wire half duplex communication
- Configurable multibuffer communication using DMA (direct memory access)
  - Buffering of received/transmitted bytes in reserved SRAM using centralized DMA
- Separate enable bits for Transmitter and Receiver
- Transfer detection flags:
  - Receive buffer full
  - Transmit buffer empty
  - End of Transmission flags

- Parity control:
  - Transmits parity bit
  - Checks parity of received data byte
- Four error detection flags:
  - Overrun error
  - Noise error
  - Frame error
  - Parity error
- Ten interrupt sources with flags:
  - CTS changes
  - LIN break detection
  - Transmit data register empty
  - Transmission complete
  - Receive data register full
  - Idle line received
  - Overrun error
  - Framing error
  - Noise error
  - Parity error
- Multiprocessor communication - enter into mute mode if address match does not occur
- Wake up from mute mode (by idle line detection or address mark detection)
- Two receiver wakeup modes: Address bit (MSB, 9<sup>th</sup> bit), Idle line

## 26.3 USART functional description

The interface is externally connected to another device by three pins (see [Figure 278](#)). Any USART bidirectional communication requires a minimum of two pins: Receive Data In (RX) and Transmit Data Out (TX):

**RX:** Receive Data Input is the serial data input. Oversampling techniques are used for data recovery by discriminating between valid incoming data and noise.

**TX:** Transmit Data Output. When the transmitter is disabled, the output pin returns to its IO port configuration. When the transmitter is enabled and nothing is to be transmitted, the TX pin is at high level. In single-wire and smartcard modes, this IO is used to transmit and receive the data (at USART level, data are then received on SW\_RX).



Through these pins, serial data is transmitted and received in normal USART mode as frames comprising:

- An Idle Line prior to transmission or reception
- A start bit
- A data word (8 or 9 bits) least significant bit first
- 0.5, 1, 1.5, 2 Stop bits indicating that the frame is complete
- This interface uses a fractional baud rate generator - with a 12-bit mantissa and 4-bit fraction
- A status register (USART\_SR)
- Data Register (USART\_DR)
- A baud rate register (USART\_BRR) - 12-bit mantissa and 4-bit fraction.
- A Guardtime Register (USART\_GTPR) in case of Smartcard mode.

Refer to [Section 26.6: USART registers on page 766](#) for the definitions of each bit.

The following pin is required to interface in synchronous mode:

- **CK:** Transmitter clock output. This pin outputs the transmitter data clock for synchronous transmission corresponding to SPI master mode (no clock pulses on start bit and stop bit, and a software option to send a clock pulse on the last data bit). In parallel data can be received synchronously on RX. This can be used to control peripherals that have shift registers (e.g. LCD drivers). The clock phase and polarity are software programmable. In smartcard mode, CK can provide the clock to the smartcard.

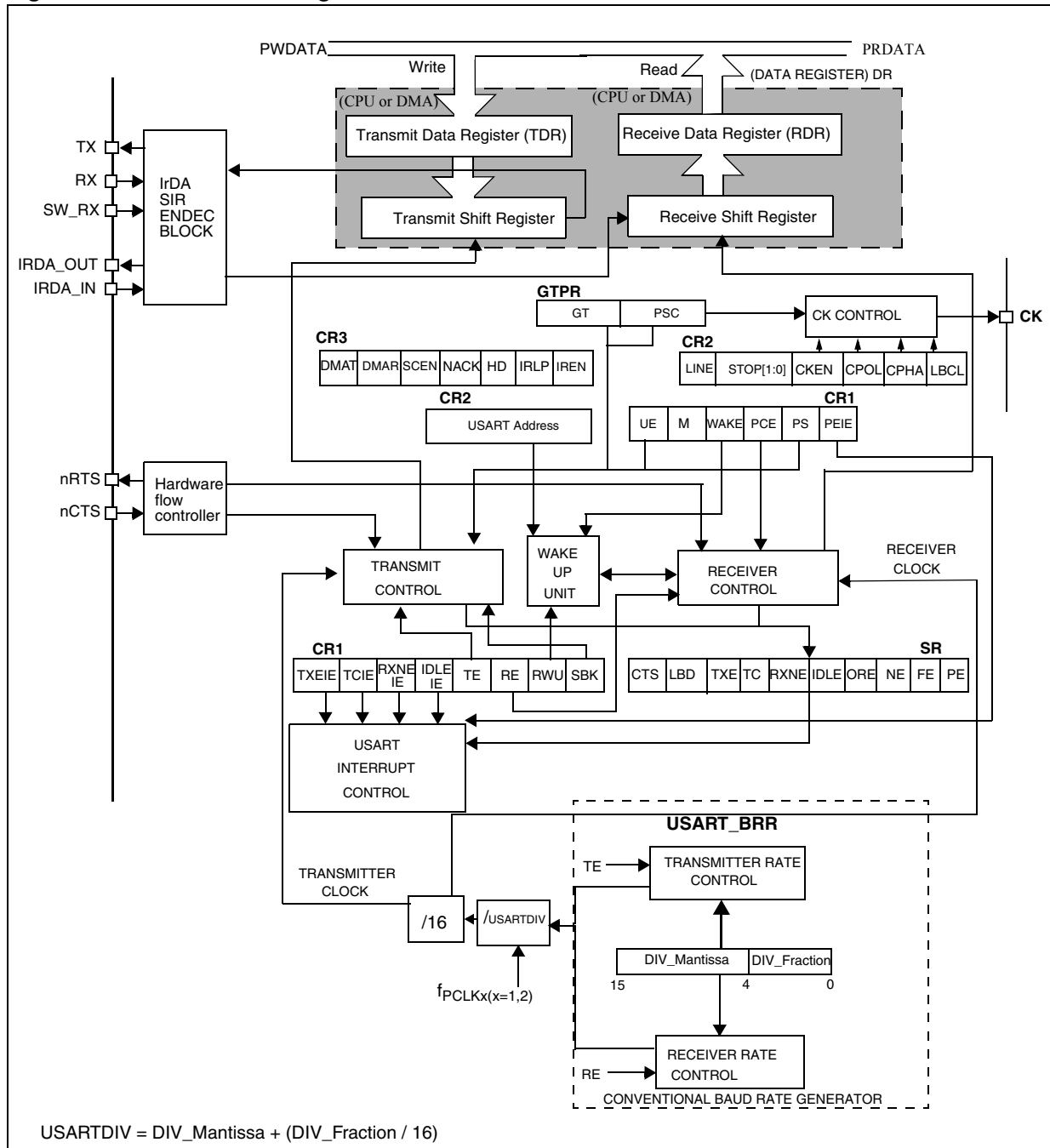
The following pins are required to interface in IrDA mode:

- **IrDA\_RDI:** Receive Data Input is the data input in IrDA mode.
- **IrDA\_TDO:** Transmit Data Output in IrDA mode.

the following pins are required in Hardware flow control mode:

- **nCTS:** Clear To Send blocks the data transmission at the end of the current transfer when high
- **nRTS:** Request to send indicates that the USART is ready to receive a data (when low).

Figure 278. USART block diagram



### 26.3.1 USART character description

Word length may be selected as being either 8 or 9 bits by programming the M bit in the USART\_CR1 register (see [Figure 279](#)).

The TX pin is in low state during the start bit. It is in high state during the stop bit.

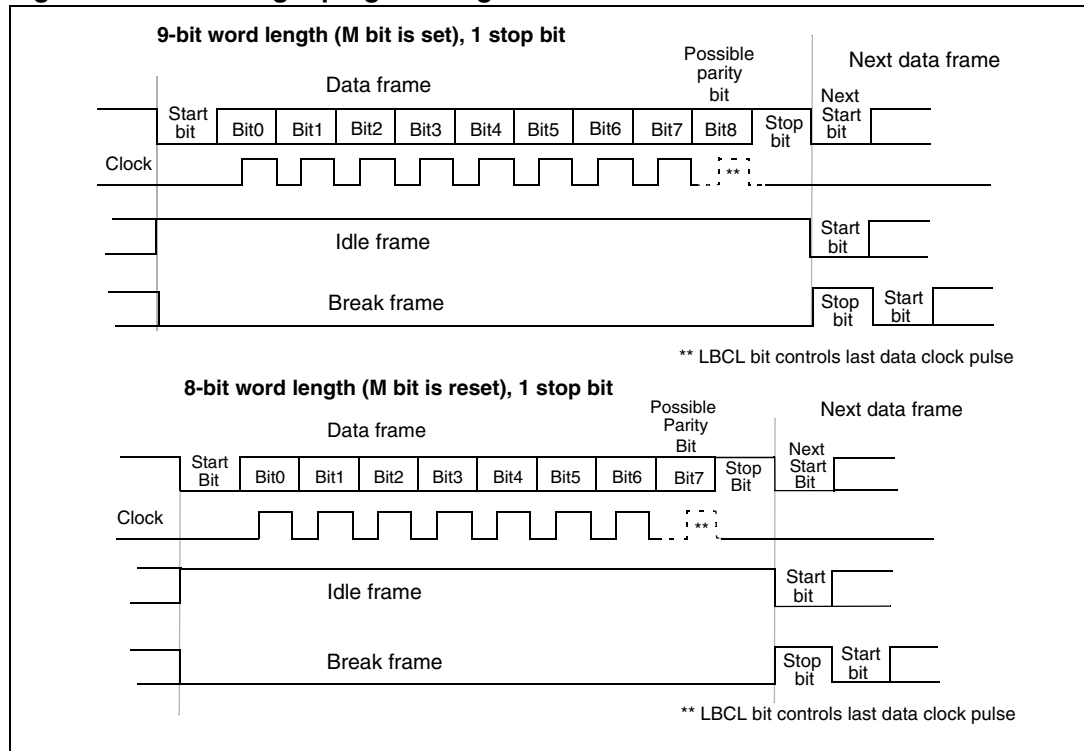
An **Idle character** is interpreted as an entire frame of “1”s followed by the start bit of the next frame which contains data (The number of “1” ‘s will include the number of stop bits).

A **Break character** is interpreted on receiving “0”s for a frame period. At the end of the break frame the transmitter inserts either 1 or 2 stop bits (logic “1” bit) to acknowledge the start bit.

Transmission and reception are driven by a common baud rate generator, the clock for each is generated when the enable bit is set respectively for the transmitter and receiver.

The details of each block is given below.

**Figure 279. Word length programming**



## 26.3.2 Transmitter

The transmitter can send data words of either 8 or 9 bits depending on the M bit status. When the transmit enable bit (TE) is set, the data in the transmit shift register is output on the TX pin and the corresponding clock pulses are output on the CK pin.

### Character transmission

During an USART transmission, data shifts out least significant bit first on the TX pin. In this mode, the USART\_DR register consists of a buffer (TDR) between the internal bus and the transmit shift register (see [Figure 278](#)).

Every character is preceded by a start bit which is a logic level low for one bit period. The character is terminated by a configurable number of stop bits.

The following stop bits are supported by USART: 0.5, 1, 1.5 and 2 stop bits.

- Note:*
- 1 *The TE bit should not be reset during transmission of data. Resetting the TE bit during the transmission will corrupt the data on the TX pin as the baud rate counters will get frozen. The current data being transmitted will be lost.*
  - 2 *An idle frame will be sent after the TE bit is enabled.*

### Configurable stop bits

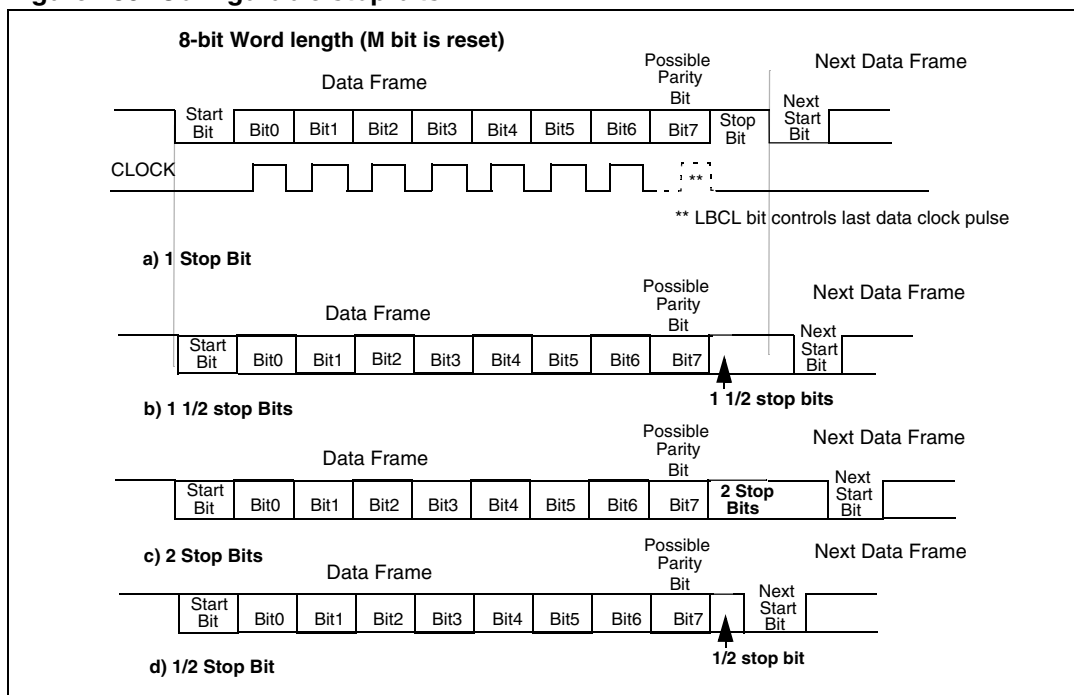
The number of stop bits to be transmitted with every character can be programmed in Control register 2, bits 13,12.

- 1 **1 stop bit:** This is the default value of number of stop bits.
- 2 **2 Stop bits:** This will be supported by normal USART, single-wire and modem modes.
- 3 **0.5 stop bit:** To be used when receiving data in Smartcard mode.
- 4 **1.5 stop bits:** To be used when transmitting and receiving data in Smartcard mode.

An idle frame transmission will include the stop bits.

A break transmission will be 10 low bits followed by the configured number of stop bits (when  $m = 0$ ) and 11 low bits followed by the configured number of stop bits (when  $m = 1$ ). It is not possible to transmit long breaks (break of length greater than 10/11 low bits).

Figure 280. Configurable stop bits



**Procedure:**

1. Enable the USART by writing the UE bit in USART\_CR1 register to 1.
2. Program the M bit in USART\_CR1 to define the word length.
3. Program the number of stop bits in USART\_CR2.
4. Select DMA enable (DMAT) in USART\_CR3 if Multi buffer Communication is to take place. Configure the DMA register as explained in multibuffer communication.
5. Select the desired baud rate using the USART\_BRR register.
6. Set the TE bit in USART\_CR1 to send an idle frame as first transmission.
7. Write the data to send in the USART\_DR register (this clears the TXE bit). Repeat this for each data to be transmitted in case of single buffer.
8. After writing the last data into the USART\_DR register, wait until TC=1. This indicates that the transmission of the last frame is complete. This is required for instance when the USART is disabled or enters the Halt mode to avoid corrupting the last transmission.

**Single byte communication**

The TXE bit is always cleared by a write to the data register.

The TXE bit is set by hardware and it indicates:

- The data has been moved from TDR to the shift register and the data transmission has started.
- The TDR register is empty.
- The next data can be written in the USART\_DR register without overwriting the previous data.

This flag generates an interrupt if the TXEIE bit is set.

When a transmission is taking place, a write instruction to the USART\_DR register stores the data in the TDR register and which is copied in the shift register at the end of the current transmission.

When no transmission is taking place, a write instruction to the USART\_DR register places the data directly in the shift register, the data transmission starts, and the TXE bit is immediately set.

If a frame is transmitted (after the stop bit) and the TXE bit is set, the TC bit goes high. An interrupt is generated if the TCIE bit is set in the USART\_CR1 register.

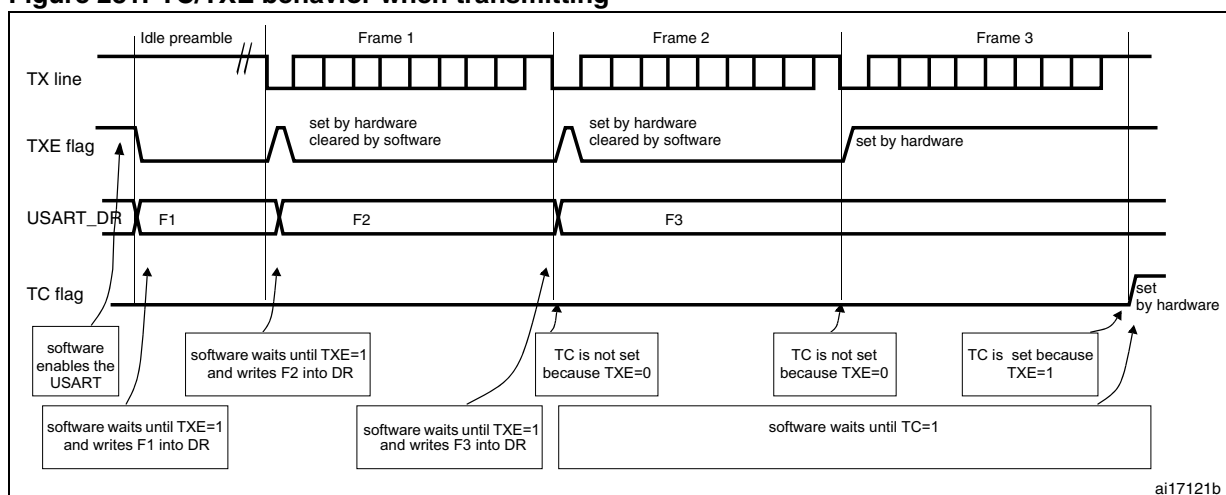
After writing the last data into the USART\_DR register, it is mandatory to wait for TC=1 before disabling the USART or causing the microcontroller to enter the low power mode (see [Figure 281: TC/TXE behavior when transmitting](#)).

The TC bit is cleared by the following software sequence:

1. A read from the USART\_SR register
2. A write to the USART\_DR register

*Note: The TC bit can also be cleared by writing a '0' to it. This clearing sequence is recommended only for Multibuffer communication.*

**Figure 281. TC/TXE behavior when transmitting**



### Break characters

Setting the SBK bit transmits a break character. The break frame length depends on the M bit (see [Figure 279](#)).

If the SBK bit is set to '1' a break character is sent on the TX line after completing the current character transmission. This bit is reset by hardware when the break character is completed (during the stop bit of the break character). The USART inserts a logic 1 bit at the end of the last break frame to guarantee the recognition of the start bit of the next frame.

*Note: If the software resets the SBK bit before the commencement of break transmission, the break character will not be transmitted. For two consecutive breaks, the SBK bit should be set after the stop bit of the previous break.*

### Idle characters

Setting the TE bit drives the USART to send an idle frame before the first data frame.

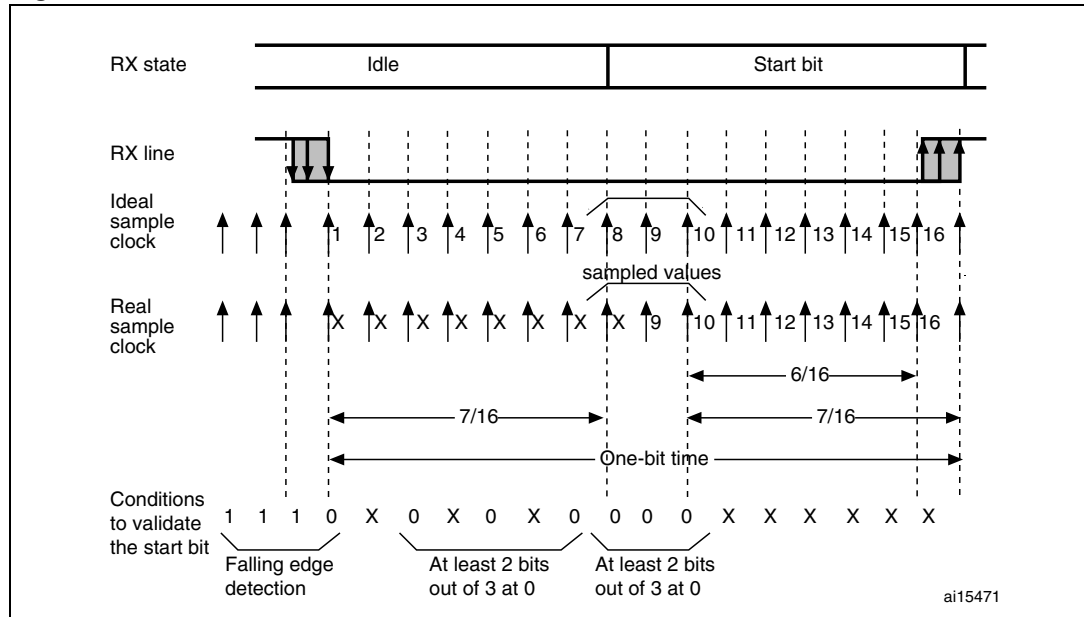
### 26.3.3 Receiver

The USART can receive data words of either 8 or 9 bits depending on the M bit in the USART\_CR1 register.

#### Start bit detection

In the USART, the start bit is detected when a specific sequence of samples is recognized. This sequence is: 1 1 1 0 X 0 X 0 X 0 0 0 0.

Figure 282. Start bit detection



**Note:** If the sequence is not complete, the start bit detection aborts and the receiver returns to the idle state (no flag is set) where it waits for a falling edge.

The start bit is confirmed (RXNE flag set, interrupt generated if RXNEIE=1) if the 3 sampled bits are at 0 (first sampling on the 3rd, 5th and 7th bits finds the 3 bits at 0 and second sampling on the 8th, 9th and 10th bits also finds the 3 bits at 0).

The start bit is validated (RXNE flag set, interrupt generated if RXNEIE=1) but the NE noise flag is set if, for both samplings, at least 2 out of the 3 sampled bits are at 0 (sampling on the 3rd, 5th and 7th bits and sampling on the 8th, 9th and 10th bits). If this condition is not met, the start detection aborts and the receiver returns to the idle state (no flag is set).

If, for one of the samplings (sampling on the 3rd, 5th and 7th bits or sampling on the 8th, 9th and 10th bits), 2 out of the 3 bits are found at 0, the start bit is validated but the NE noise flag bit is set.

#### Character reception

During an USART reception, data shifts in least significant bit first through the RX pin. In this mode, the USART\_DR register consists of a buffer (RDR) between the internal bus and the received shift register.

Procedure:

1. Enable the USART by writing the UE bit in USART\_CR1 register to 1.
2. Program the M bit in USART\_CR1 to define the word length.
3. Program the number of stop bits in USART\_CR2.
4. Select DMA enable (DMAR) in USART\_CR3 if multibuffer communication is to take place. Configure the DMA register as explained in multibuffer communication. STEP 3
5. Select the desired baud rate using the baud rate register USART\_BRR
6. Set the RE bit USART\_CR1. This enables the receiver which begins searching for a start bit.

When a character is received

- The RXNE bit is set. It indicates that the content of the shift register is transferred to the RDR. In other words, data has been received and can be read (as well as its associated error flags).
- An interrupt is generated if the RXNEIE bit is set.
- The error flags can be set if a frame error, noise or an overrun error has been detected during reception.
- In multibuffer, RXNE is set after every byte received and is cleared by the DMA read to the Data Register.
- In single buffer mode, clearing the RXNE bit is performed by a software read to the USART\_DR register. The RXNE flag can also be cleared by writing a zero to it. The RXNE bit must be cleared before the end of the reception of the next character to avoid an overrun error.

*Note:* The RE bit should not be reset while receiving data. If the RE bit is disabled during reception, the reception of the current byte will be aborted.

### Break character

When a break character is received, the USART handles it as a framing error.

### Idle character

When an idle frame is detected, there is the same procedure as a data received character plus an interrupt if the IDLEIE bit is set.

### Overrun error

An overrun error occurs when a character is received when RXNE has not been reset. Data can not be transferred from the shift register to the RDR register until the RXNE bit is cleared.



The RXNE flag is set after every byte received. An overrun error occurs if RXNE flag is set when the next data is received or the previous DMA request has not been serviced. When an overrun error occurs:

- The ORE bit is set.
- The RDR content will not be lost. The previous data is available when a read to USART\_DR is performed.
- The shift register will be overwritten. After that point, any data received during overrun is lost.
- An interrupt is generated if either the RXNEIE bit is set or both the EIE and DMAR bits are set.
- The ORE bit is reset by a read to the USART\_SR register followed by a USART\_DR register read operation.

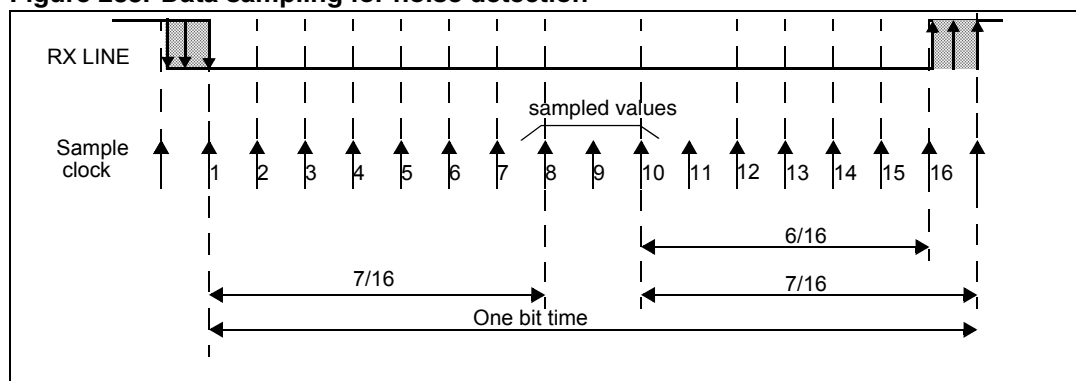
*Note: The ORE bit, when set, indicates that at least 1 data has been lost. There are two possibilities:*

- *if RXNE=1, then the last valid data is stored in the receive register RDR and can be read,*
- *if RXNE=0, then it means that the last valid data has already been read and thus there is nothing to be read in the RDR. This case can occur when the last valid data is read in the RDR at the same time as the new (and lost) data is received. It may also occur when the new data is received during the reading sequence (between the USART\_SR register read access and the USART\_DR read access).*

**Noise error**

Over-sampling techniques are used (except in synchronous mode) for data recovery by discriminating between valid incoming data and noise.

**Figure 283. Data sampling for noise detection**



**Table 188. Noise detection from sampled data**

Sampled value	NE status	Received bit value	Data validity
000	0	0	Valid
001	1	0	Not Valid
010	1	0	Not Valid
011	1	1	Not Valid
100	1	0	Not Valid

**Table 188. Noise detection from sampled data**

Sampled value	NE status	Received bit value	Data validity
101	1	1	Not Valid
110	1	1	Not Valid
111	0	1	Valid

When noise is detected in a frame:

- The NE is set at the rising edge of the RXNE bit.
- The invalid data is transferred from the Shift register to the USART\_DR register.
- No interrupt is generated in case of single byte communication. However this bit rises at the same time as the RXNE bit which itself generates an interrupt. In case of multibuffer communication an interrupt will be issued if the EIE bit is set in the USART\_CR3 register.

The NE bit is reset by a USART\_SR register read operation followed by a USART\_DR register read operation.

**Framing error**

A framing error is detected when:

The stop bit is not recognized on reception at the expected time, following either a de-synchronization or excessive noise.

When the framing error is detected:

- The FE bit is set by hardware
- The invalid data is transferred from the Shift register to the USART\_DR register.
- No interrupt is generated in case of single byte communication. However this bit rises at the same time as the RXNE bit which itself generates an interrupt. In case of multibuffer communication an interrupt will be issued if the EIE bit is set in the USART\_CR3 register.

The FE bit is reset by a USART\_SR register read operation followed by a USART\_DR register read operation.

**Configurable stop bits during reception**

The number of stop bits to be received can be configured through the control bits of Control Register 2 - it can be either 1 or 2 in normal mode and 0.5 or 1.5 in Smartcard mode.

1. **0.5 stop bit (reception in Smartcard mode):** No sampling is done for 0.5 stop bit. As a consequence, no framing error and no break frame can be detected when 0.5 stop bit is selected.
2. **1 stop bit:** Sampling for 1 stop Bit is done on the 8th, 9th and 10th samples.
3. **1.5 stop bits (Smartcard mode):** When transmitting in smartcard mode, the device must check that the data is correctly sent. Thus the receiver block must be enabled (RE =1 in the USART\_CR1 register) and the stop bit is checked to test if the smartcard has detected a parity error. In the event of a parity error, the smartcard forces the data signal low during the sampling - NACK signal-, which is flagged as a framing error. Then, the FE flag is set with the RXNE at the end of the 1.5 stop bit. Sampling for 1.5 stop bits is done on the 16th, 17th and 18th samples (1 baud clock period after the beginning of the stop bit). The 1.5 stop bit can be decomposed into 2 parts: one 0.5

baud clock period during which nothing happens, followed by 1 normal stop bit period during which sampling occurs halfway through. Refer to [Section 26.3.11: Smartcard on page 757](#) for more details.

4. **2 stop bits:** Sampling for 2 stop bits is done on the 8th, 9th and 10th samples of the first stop bit. If a framing error is detected during the first stop bit the framing error flag will be set. The second stop bit is not checked for framing error. The RXNE flag will be set at the end of the first stop bit.

### 26.3.4 Fractional baud rate generation

The baud rate for the receiver and transmitter (Rx and Tx) are both set to the same value as programmed in the Mantissa and Fraction values of USARTDIV.

$$\text{Tx/ Rx baud} = \frac{f_{\text{CK}}}{(16 * \text{USARTDIV})}$$

legend:  $f_{\text{CK}}$  - Input clock to the peripheral (PCLK1 for USART2, 3, 4, 5 or PCLK2 for USART1)

USARTDIV is an unsigned fixed point number that is coded on the USART\_BRR register.

*Note:* The baud counters are updated with the new value of the Baud registers after a write to USART\_BRR. Hence the Baud rate register value should not be changed during communication.

#### How to derive USARTDIV from USART\_BRR register values

##### Example 1:

If DIV\_Mantissa = 0d27 and DIV\_Fraction = 0d12 (USART\_BRR = 0x1BC), then

Mantissa (USARTDIV) = 0d27

Fraction (USARTDIV) = 12/16 = 0d0.75

Therefore USARTDIV = 0d27.75

##### Example 2:

To program USARTDIV = 0d25.62

This leads to:

DIV\_Fraction = 16\*0d0.62 = 0d9.92

The nearest real number is 0d10 = 0xA

DIV\_Mantissa = mantissa (0d25.620) = 0d25 = 0x19

Then, USART\_BRR = 0x19A hence USARTDIV = 0d25.625

##### Example 3:

To program USARTDIV = 0d50.99

This leads to:

DIV\_Fraction = 16\*0d0.99 = 0d15.84

The nearest real number is  $0d16 = 0x10 \Rightarrow$  overflow of  $DIV\_frac[3:0] \Rightarrow$  carry must be added up to the mantissa

$DIV\_Mantissa = \text{mantissa} (0d50.990 + \text{carry}) = 0d51 = 0x33$

Then,  $USART\_BRR = 0x330$  hence  $USARTDIV = 0d51.000$

**Table 189. Error calculation for programmed baud rates**

Baud rate		f <sub>PCLK</sub> = 36 MHz			f <sub>PCLK</sub> = 72 MHz		
S.No	in Kbps	Actual	Value programmed in the Baud Rate register	% Error = (Calculated - Desired)B.Rate / Desired B.Rate	Actual	Value programmed in the Baud Rate register	% Error
1.	2.4	2.400	937.5	0%	2.4	1875	0%
2.	9.6	9.600	234.375	0%	9.6	468.75	0%
3.	19.2	19.2	117.1875	0%	19.2	234.375	0%
4.	57.6	57.6	39.0625	0%	57.6	78.125	0.0%
5.	115.2	115.384	19.5	0.15%	115.2	39.0625	0%
6.	230.4	230.769	9.75	0.16%	230.769	19.5	0.16%
7.	460.8	461.538	4.875	0.16%	461.538	9.75	0.16%
8.	921.6	923.076	2.4375	0.16%	923.076	4.875	0.16%
9.	2250	2250	1	0%	2250	2	0%
10.	4500	NA	NA	NA	4500	1	0%

- Note:*
- 1 The lower the CPU clock the lower will be the accuracy for a particular Baud rate. The upper limit of the achievable baud rate can be fixed with this data.
  - 2 Only USART1 is clocked with PCLK2 (72 MHz Max). Other USARTs are clocked with PCLK1 (36 MHz Max).

### 26.3.5 USART receiver’s tolerance to clock deviation

The USART’s asynchronous receiver works correctly only if the total clock system deviation is smaller than the USART receiver’s tolerance. The causes which contribute to the total deviation are:

- DTRA: Deviation due to the transmitter error (which also includes the deviation of the transmitter’s local oscillator)
- DQUANT: Error due to the baud rate quantization of the receiver
- DREC: Deviation of the receiver’s local oscillator
- DTCL: Deviation due to the transmission line (generally due to the transceivers which can introduce an asymmetry between the low-to-high transition timing and the high-to-low transition timing)

$$DTRA + DQUANT + DREC + DTCL < \text{USART receiver’s tolerance}$$

The USART receiver’s tolerance to properly receive data is equal to the maximum tolerated deviation and depends on the following choices:

- 10- or 11-bit character length defined by the M bit in the USART\_CR1 register
- use of fractional baud rate or not

**Table 190. USART receiver ‘s tolerance when DIV\_Fraction is 0**

M bit	NF is an error	NF is don’t care
0	3.75%	4.375%
1	3.41%	3.97%

**Table 191. USART receiver’s tolerance when DIV\_Fraction is different from 0**

M bit	NF is an error	NF is don’t care
0	3.33%	3.88%
1	3.03%	3.53%

*Note:* The figures specified in [Table 190](#) and [Table 191](#) may slightly differ in the special case when the received frames contain some Idle frames of exactly 10-bit times when M=0 (11-bit times when M=1).

### 26.3.6 Multiprocessor communication

There is a possibility of performing multiprocessor communication with the USART (several USARTs connected in a network). For instance one of the USARTs can be the master, its TX output is connected to the RX input of the other USART. The others are slaves, their respective TX outputs are logically ANDed together and connected to the RX input of the master.

In multiprocessor configurations it is often desirable that only the intended message recipient should actively receive the full message contents, thus reducing redundant USART service overhead for all non addressed receivers.

The non addressed devices may be placed in mute mode by means of the muting function. In mute mode:

- None of the reception status bits can be set.
- All the receive interrupts are inhibited.
- The RWU bit in USART\_CR1 register is set to 1. RWU can be controlled automatically by hardware or written by the software under certain conditions.

The USART can enter or exit from mute mode using one of two methods, depending on the WAKE bit in the USART\_CR1 register:

- Idle Line detection if the WAKE bit is reset,
- Address Mark detection if the WAKE bit is set.

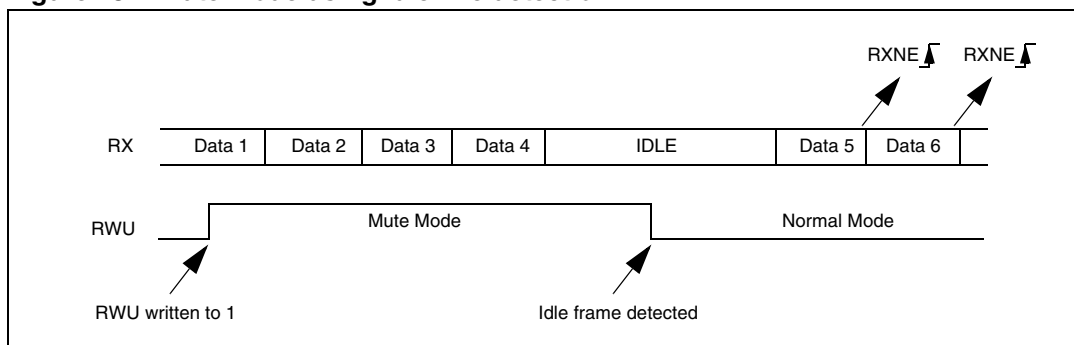
#### Idle line detection (WAKE=0)

The USART enters mute mode when the RWU bit is written to 1.

It wakes up when an Idle frame is detected. Then the RWU bit is cleared by hardware but the IDLE bit is not set in the USART\_SR register. RWU can also be written to 0 by software.

An example of mute mode behavior using idle line detection is given in [Figure 284](#).

Figure 284. Mute mode using Idle line detection



**Address mark detection (WAKE=1)**

In this mode, bytes are recognized as addresses if their MSB is a ‘1’ else they are considered as data. In an address byte, the address of the targeted receiver is put on the 4 LSB. This 4-bit word is compared by the receiver with its own address which is programmed in the ADD bits in the USART\_CR2 register.

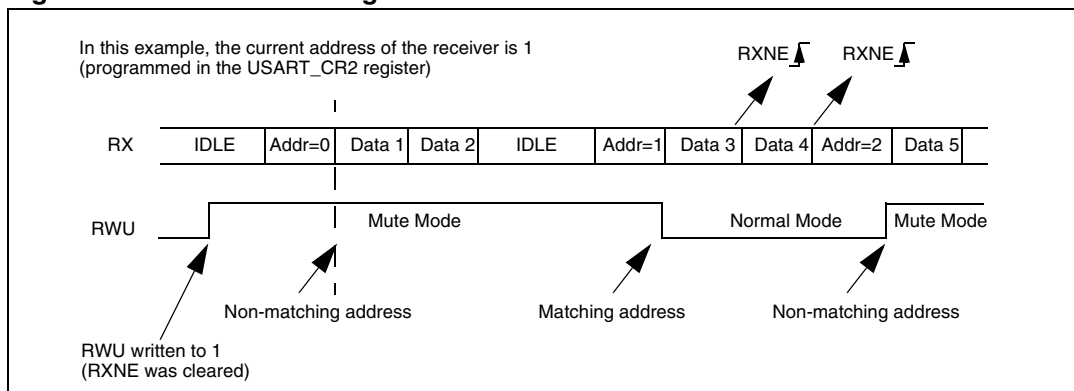
The USART enters mute mode when an address character is received which does not match its programmed address. In this case, the RWU bit is set by hardware. The RXNE flag is not set for this address byte and no interrupt nor DMA request is issued as the USART would have entered mute mode.

It exits from mute mode when an address character is received which matches the programmed address. Then the RWU bit is cleared and subsequent bytes are received normally. The RXNE bit is set for the address character since the RWU bit has been cleared.

The RWU bit can be written to as 0 or 1 when the receiver buffer contains no data (RXNE=0 in the USART\_SR register). Otherwise the write attempt is ignored.

An example of mute mode behavior using address mark detection is given in [Figure 285](#).

Figure 285. Mute mode using Address mark detection



**26.3.7 Parity control**

Parity control (generation of parity bit in transmission and parity checking in reception) can be enabled by setting the PCE bit in the USART\_CR1 register. Depending on the frame length defined by the M bit, the possible USART frame formats are as listed in [Table 192](#).

**Table 192. Frame formats<sup>(1)</sup>**

M bit	PCE bit	USART frame
0	0	SB   8 bit data   STB
0	1	SB   7-bit data   PB   STB
1	0	SB   9-bit data   STB
1	1	SB   8-bit data PB   STB

1. Legends: SB: Start Bit, STB: Stop Bit, PB: Parity Bit

*Note:* In case of wake up by an address mark, the MSB bit of the data is taken into account and not the parity bit

**Even parity:** the parity bit is calculated to obtain an even number of “1s” inside the frame made of the 7 or 8 LSB bits (depending on whether M is equal to 0 or 1) and the parity bit.

Ex: data=00110101; 4 bits set => parity bit will be 0 if even parity is selected (PS bit in USART\_CR1 = 0).

**Odd parity:** the parity bit is calculated to obtain an odd number of “1s” inside the frame made of the 7 or 8 LSB bits (depending on whether M is equal to 0 or 1) and the parity bit.

Ex: data=00110101; 4 bits set => parity bit will be 1 if odd parity is selected (PS bit in USART\_CR1 = 1).

**Transmission mode:** If the PCE bit is set in USART\_CR1, then the MSB bit of the data written in the data register is transmitted but is changed by the parity bit (even number of “1s” if even parity is selected (PS=0) or an odd number of “1s” if odd parity is selected (PS=1)). If the parity check fails, the PE flag is set in the USART\_SR register and an interrupt is generated if PEIE is set in the USART\_CR1 register.

### 26.3.8 LIN (local interconnection network) mode

The LIN mode is selected by setting the LINEN bit in the USART\_CR2 register. In LIN mode, the following bits must be kept cleared:

- CLKEN in the USART\_CR2 register,
- STOP[1:0], SCEN, HDSEL and IREN in the USART\_CR3 register.

#### LIN transmission

The same procedure explained in [Section 26.3.2](#) has to be applied for LIN Master transmission than for normal USART transmission with the following differences:

- Clear the M bit to configure 8-bit word length.
- Set the LINEN bit to enter LIN mode. In this case, setting the SBK bit sends 13 ‘0’ bits as a break character. Then a bit of value ‘1’ is sent to allow the next start detection.

#### LIN reception

When the LIN mode is enabled, the break detection circuit is activated. The detection is totally independent from the normal USART receiver. A break can be detected whenever it occurs, during idle state or during a frame.

When the receiver is enabled (RE=1 in USART\_CR1), the circuit looks at the RX input for a start signal. The method for detecting start bits is the same when searching break

characters or data. After a start bit has been detected, the circuit samples the next bits exactly like for the data (on the 8th, 9th and 10th samples). If 10 (when the LBDL = 0 in USART\_CR2) or 11 (when LBDL=1 in USART\_CR2) consecutive bits are detected as '0', and are followed by a delimiter character, the LBD flag is set in USART\_SR. If the LBDIE bit=1, an interrupt is generated. Before validating the break, the delimiter is checked for as it signifies that the RX line has returned to a high level.

If a '1' is sampled before the 10 or 11 have occurred, the break detection circuit cancels the current detection and searches for a start bit again.

If the LIN mode is disabled (LINEN=0), the receiver continues working as normal USART, without taking into account the break detection.

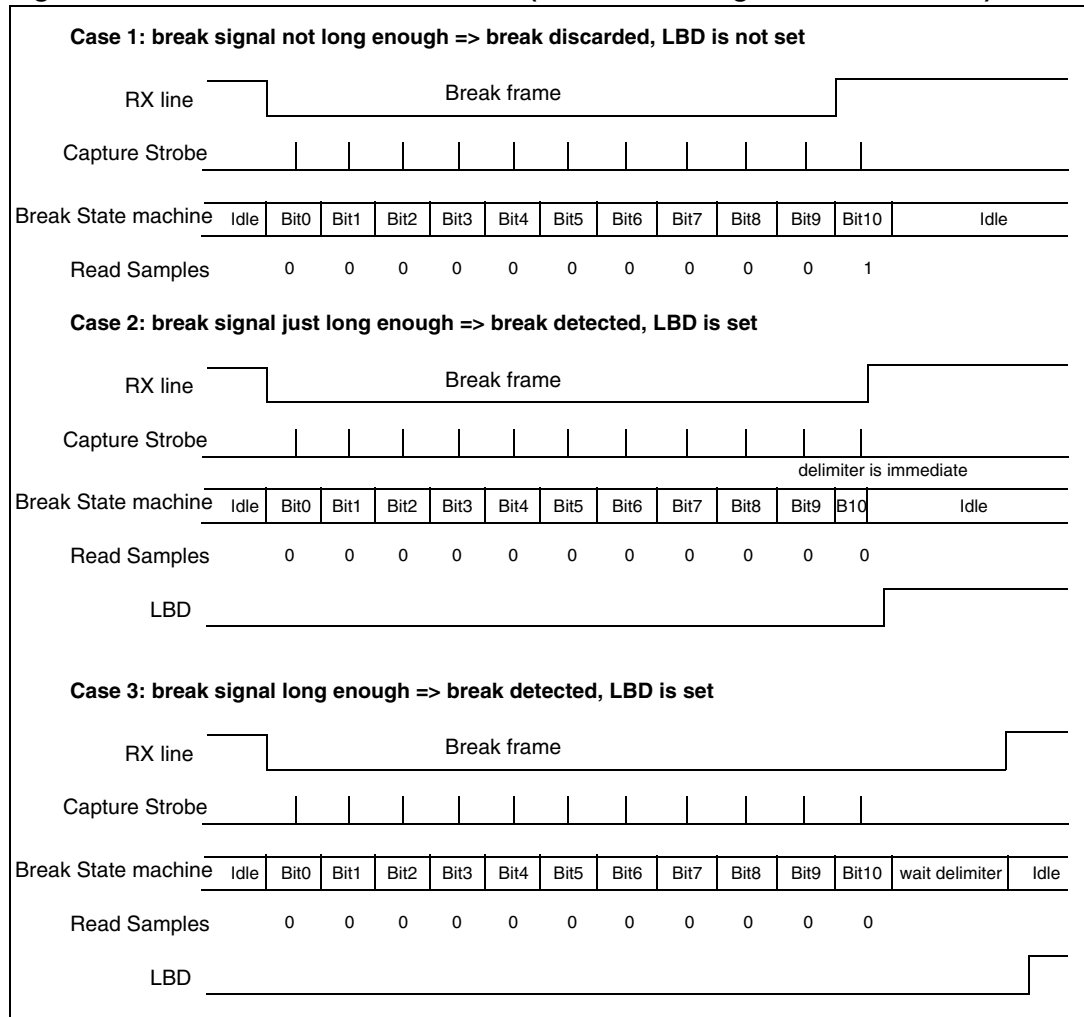
If the LIN mode is enabled (LINEN=1), as soon as a framing error occurs (i.e. stop bit detected at '0', which will be the case for any break frame), the receiver stops until the break detection circuit receives either a '1', if the break word was not complete, or a delimiter character if a break has been detected.

The behavior of the break detector state machine and the break flag is shown on the [Figure 286: Break detection in LIN mode \(11-bit break length - LBDL bit is set\) on page 753](#).

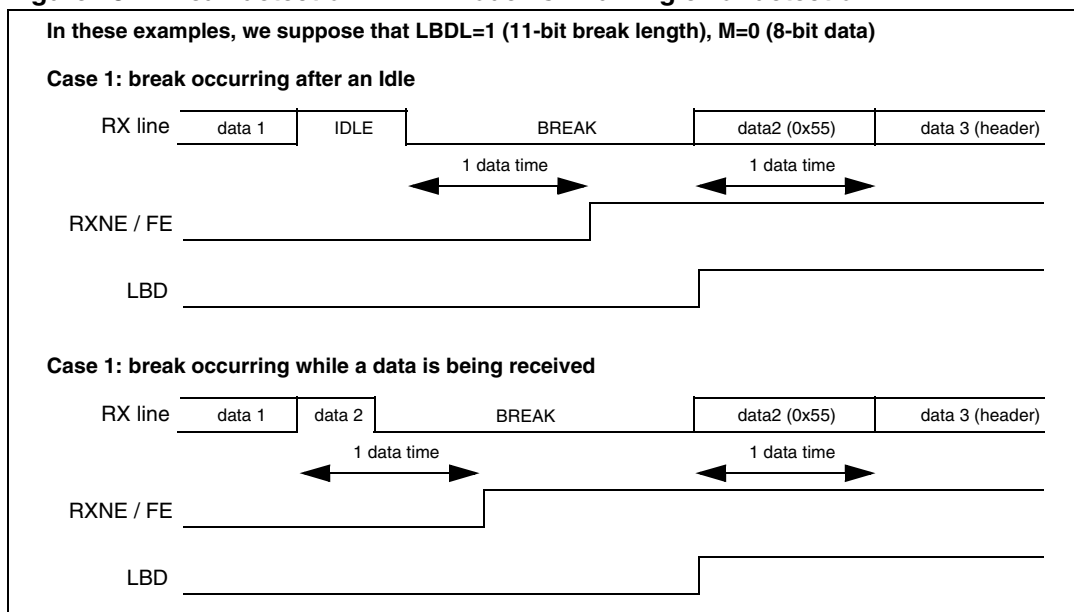
Examples of break frames are given on [Figure 287: Break detection in LIN mode vs. Framing error detection on page 754](#).



**Figure 286. Break detection in LIN mode (11-bit break length - LBDL bit is set)**



**Figure 287. Break detection in LIN mode vs. Framing error detection**



### 26.3.9 USART synchronous mode

The synchronous mode is selected by writing the CLKEN bit in the USART\_CR2 register to 1. In synchronous mode, the following bits must be kept cleared:

- LINEN bit in the USART\_CR2 register,
- SCEN, HDSEL and IREN bits in the USART\_CR3 register.

The USART allows the user to control a bidirectional synchronous serial communications in master mode. The CK pin is the output of the USART transmitter clock. No clock pulses are sent to the CK pin during start bit and stop bit. Depending on the state of the LBCL bit in the USART\_CR2 register clock pulses will or will not be generated during the last valid data bit (address mark). The CPOL bit in the USART\_CR2 register allows the user to select the clock polarity, and the CPHA bit in the USART\_CR2 register allows the user to select the phase of the external clock (see [Figure 288](#), [Figure 289](#) & [Figure 290](#)).

During idle, preamble and send break, the external CK clock is not activated.

In synchronous mode the USART transmitter works exactly like in asynchronous mode. But as CK is synchronized with TX (according to CPOL and CPHA), the data on TX is synchronous.

In this mode the USART receiver works in a different manner compared to the asynchronous mode. If RE=1, the data is sampled on CK (rising or falling edge, depending on CPOL and CPHA), without any oversampling. A setup and a hold time must be respected (which depends on the baud rate: 1/16 bit time).

- Note:*
- 1 The CK pin works in conjunction with the TX pin. Thus, the clock is provided only if the transmitter is enabled (TE=1) and a data is being transmitted (the data register USART\_DR has been written). This means that it is not possible to receive a synchronous data without transmitting data.
  - 2 The LBCL, CPOL and CPHA bits have to be selected when both the transmitter and the receiver are disabled (TE=RE=0) to ensure that the clock pulses function correctly. These bits should not be changed while the transmitter or the receiver is enabled.

- 3 It is advised that TE and RE are set in the same instruction in order to minimize the setup and the hold time of the receiver.
- 4 The USART supports master mode only: it cannot receive or send data related to an input clock (CK is always an output).

Figure 288. USART example of synchronous transmission

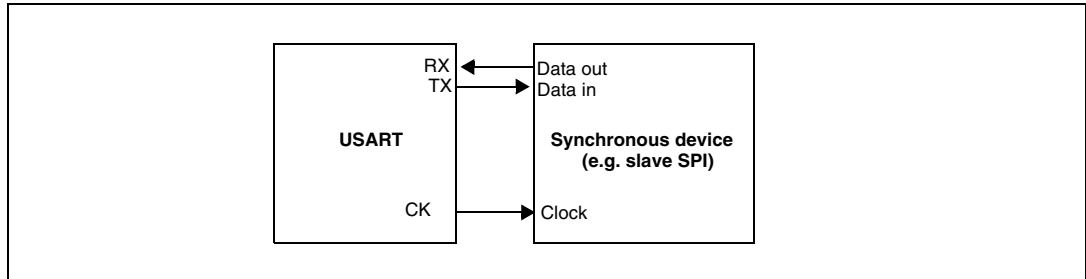
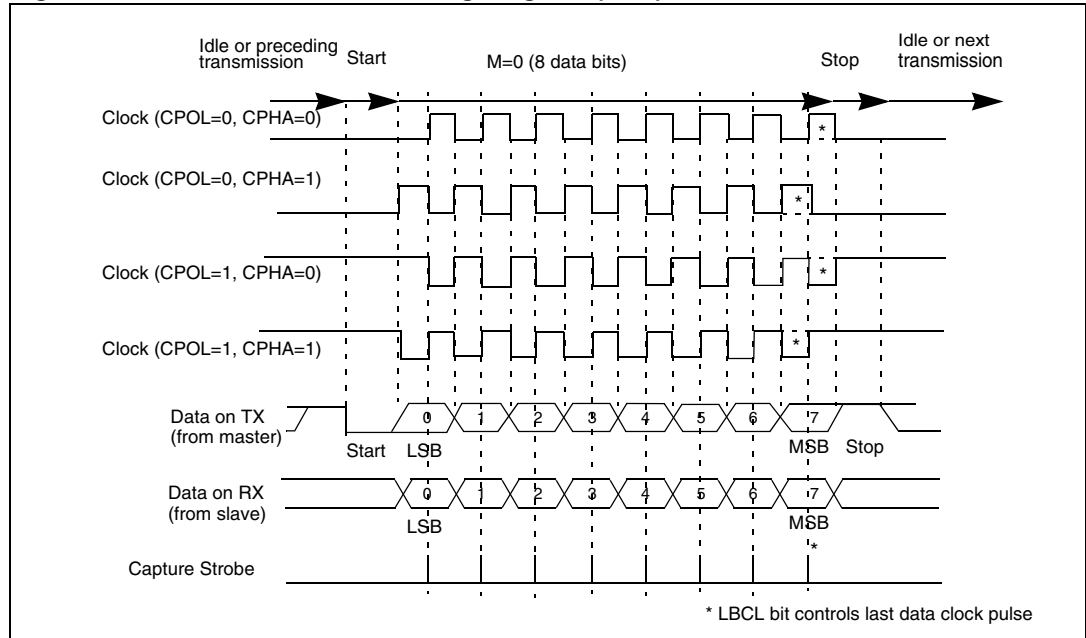
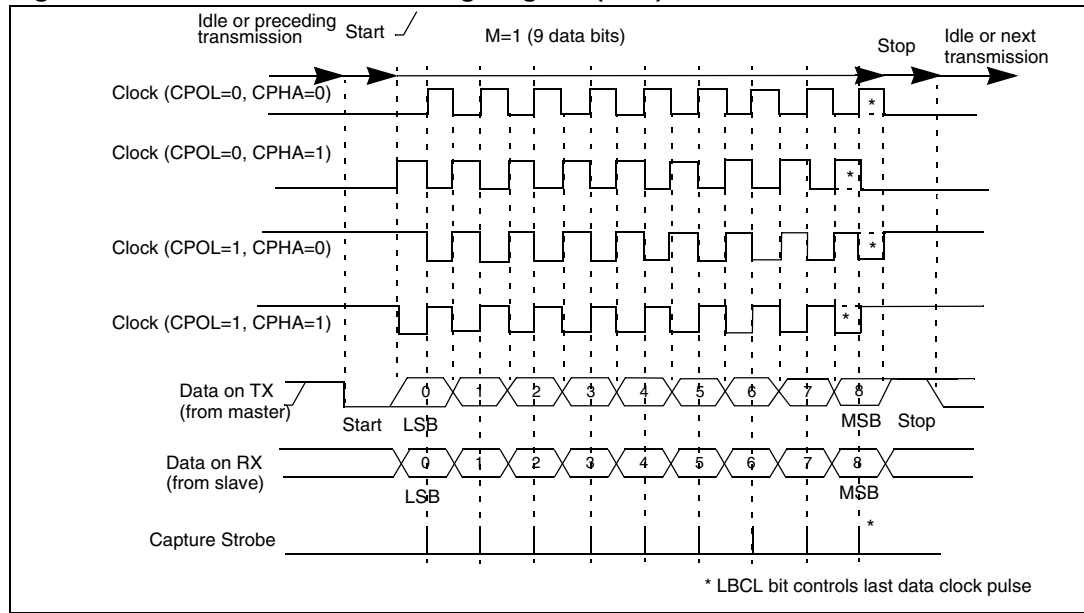


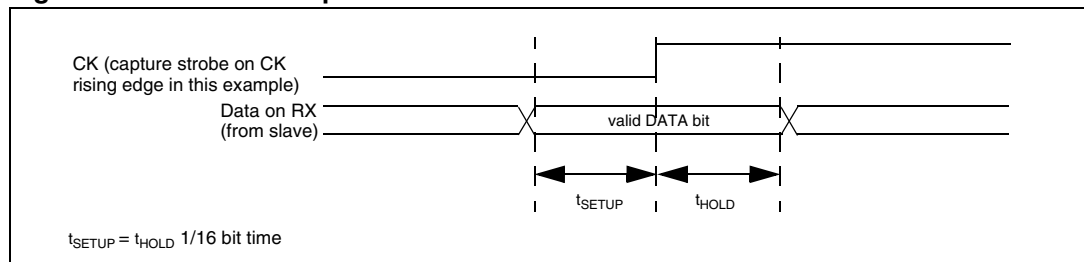
Figure 289. USART data clock timing diagram (M=0)



**Figure 290. USART data clock timing diagram (M=1)**



**Figure 291. RX data setup/hold time**



*Note:* The function of CK is different in Smartcard mode. Refer to the Smartcard mode chapter for more details.

### 26.3.10 Single-wire half-duplex communication

The single-wire half-duplex mode is selected by setting the HDSEL bit in the USART\_CR3 register. In this mode, the following bits must be kept cleared:

- LINEN and CLKEN bits in the USART\_CR2 register,
- SCEN and IREN bits in the USART\_CR3 register.

The USART can be configured to follow a single-wire half-duplex protocol. In single-wire half-duplex mode, the TX and RX pins are connected internally. The selection between half- and full-duplex communication is made with a control bit 'HALF DUPLEX SEL' (HDSEL in USART\_CR3).

As soon as HDSEL is written to 1:

- RX is no longer used,
- TX is always released when no data is transmitted. Thus, it acts as a standard IO in idle or in reception. It means that the IO must be configured so that TX is configured as floating input (or output high open-drain) when not driven by the USART.

Apart from this, the communications are similar to what is done in normal USART mode. The conflicts on the line must be managed by the software (by the use of a centralized arbiter, for instance). In particular, the transmission is never blocked by hardware and continue to occur as soon as a data is written in the data register while the TE bit is set.

### 26.3.11 Smartcard

The Smartcard mode is selected by setting the SCEN bit in the USART\_CR3 register. In smartcard mode, the following bits must be kept cleared:

- LINEN bit in the USART\_CR2 register,
- HDSEL and IREN bits in the USART\_CR3 register.

Moreover, the CLKEN bit may be set in order to provide a clock to the smartcard.

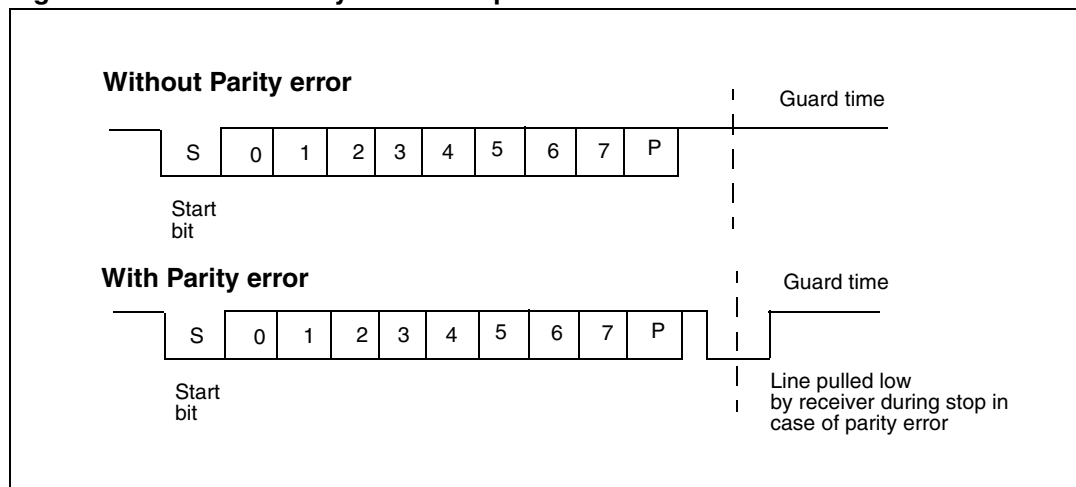
The Smartcard interface is designed to support asynchronous protocol Smartcards as defined in the ISO 7816-3 standard. The USART should be configured as:

- 8 bits plus parity: where M=1 and PCE=1 in the USART\_CR1 register
- 1.5 stop bits when transmitting and receiving : where STOP='11' in the USART\_CR2 register.

*Note: It is also possible to choose 0.5 stop bit for receiving but it is recommended to use 1.5 stop bits for both transmitting and receiving to avoid switching between the two configurations.*

Figure 292 shows examples of what can be seen on the data line with and without parity error.

**Figure 292. ISO 7816-3 asynchronous protocol**



When connected to a smartcard, the TX output of the USART drives a bidirectional line that the smartcard also drives into. To do so, SW\_RX must be connected on the same IO than TX at product level. The Transmitter output enable TX\_EN is asserted during the transmission of the start bit and the data byte, and is deasserted during the stop bit (weak pull up), so that the receive can drive the line in case of a parity error. If TX\_EN is not used, TX is driven at high level during the stop bit: Thus the receiver can drive the line as long as TX is configured in open-drain.

Smartcard is a single wire half duplex communication protocol.

- Transmission of data from the transmit shift register is guaranteed to be delayed by a minimum of 1/2 baud clock. In normal operation a full transmit shift register will start

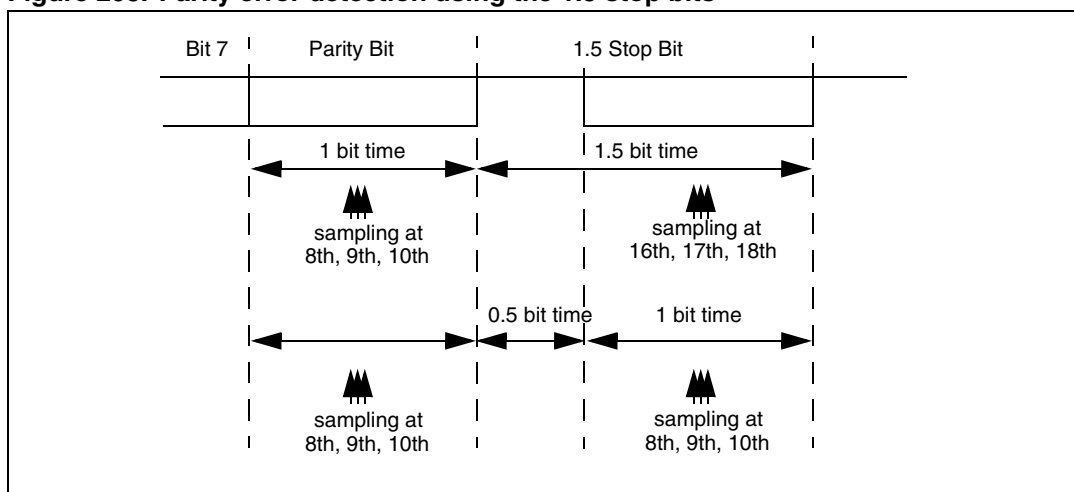
shifting on the next baud clock edge. In Smartcard mode this transmission is further delayed by a guaranteed 1/2 baud clock.

- If a parity error is detected during reception of a frame programmed with a 0.5 or 1.5 stop bit period, the transmit line is pulled low for a baud clock period after the completion of the receive frame. This is to indicate to the Smartcard that the data transmitted to USART has not been correctly received. This NACK signal (pulling transmit line low for 1 baud clock) will cause a framing error on the transmitter side (configured with 1.5 stop bits). The application can handle re-sending of data according to the protocol. A parity error is 'NACK'ed by the receiver if the NACK control bit is set, otherwise a NACK is not transmitted.
- The assertion of the TC flag can be delayed by programming the Guard Time register. In normal operation, TC is asserted when the transmit shift register is empty and no further transmit requests are outstanding. In Smartcard mode an empty transmit shift register triggers the guard time counter to count up to the programmed value in the Guard Time register. TC is forced low during this time. When the guard time counter reaches the programmed value TC is asserted high.
- The de-assertion of TC flag is unaffected by Smartcard mode.
- If a framing error is detected on the transmitter end (due to a NACK from the receiver), the NACK will not be detected as a start bit by the receive block of the transmitter. According to the ISO protocol, the duration of the received NACK can be 1 or 2 baud clock periods.
- On the receiver side, if a parity error is detected and a NACK is transmitted the receiver will not detect the NACK as a start bit.

- Note: 1 A break character is not significant in Smartcard mode. A 0x00 data with a framing error will be treated as data and not as a break.
- 2 No IDLE frame is transmitted when toggling the TE bit. The IDLE frame (as defined for the other configurations) is not defined by the ISO protocol.

Figure 293 details how the NACK signal is sampled by the USART. In this example the USART is transmitting a data and is configured with 1.5 stop bits. The receiver part of the USART is enabled in order to check the integrity of the data and the NACK signal.

Figure 293. Parity error detection using the 1.5 stop bits



The USART can provide a clock to the smartcard through the CK output. In smartcard mode, CK is not associated to the communication but is simply derived from the internal

peripheral input clock through a 5-bit prescaler. The division ratio is configured in the prescaler register USART\_GTPR. CK frequency can be programmed from  $f_{CK}/2$  to  $f_{CK}/62$ , where  $f_{CK}$  is the peripheral input clock.

### 26.3.12 IrDA SIR ENDEC block

The IrDA mode is selected by setting the IREN bit in the USART\_CR3 register. In IrDA mode, the following bits must be kept cleared:

- LINEN, STOP and CLKEN bits in the USART\_CR2 register,
- SCEN and HDSEL bits in the USART\_CR3 register.

The IrDA SIR physical layer specifies use of a Return to Zero, Inverted (RZI) modulation scheme that represents logic 0 as an infrared light pulse (see [Figure 294](#)).

The SIR Transmit encoder modulates the Non Return to Zero (NRZ) transmit bit stream output from USART. The output pulse stream is transmitted to an external output driver and infrared LED. USART supports only bit rates up to 115.2Kbps for the SIR ENDEC. In normal mode the transmitted pulse width is specified as 3/16 of a bit period.

The SIR receive decoder demodulates the return-to-zero bit stream from the infrared detector and outputs the received NRZ serial bit stream to USART. The decoder input is normally HIGH (marking state) in the idle state. The transmit encoder output has the opposite polarity to the decoder input. A start bit is detected when the decoder input is low.

- IrDA is a half duplex communication protocol. If the Transmitter is busy (i.e. the USART is sending data to the IrDA encoder), any data on the IrDA receive line will be ignored by the IrDA decoder and if the Receiver is busy (USART is receiving decoded data from the USART), data on the TX from the USART to IrDA will not be encoded by IrDA. While receiving data, transmission should be avoided as the data to be transmitted could be corrupted.
- A '0' is transmitted as a high pulse and a '1' is transmitted as a '0'. The width of the pulse is specified as 3/16th of the selected bit period in normal mode (see [Figure 295](#)).
- The SIR decoder converts the IrDA compliant receive signal into a bit stream for USART.
- The SIR receive logic interprets a high state as a logic one and low pulses as logic zeros.
- The transmit encoder output has the opposite polarity to the decoder input. The SIR output is in low state when idle.
- The IrDA specification requires the acceptance of pulses greater than 1.41 us. The acceptable pulse width is programmable. Glitch detection logic on the receiver end filters out pulses of width less than 2 PSC periods (PSC is the prescaler value programmed in the IrDA low-power Baud Register, USART\_GTPR). Pulses of width less than 1 PSC period are always rejected, but those of width greater than one and less than two periods may be accepted or rejected, those greater than 2 periods will be accepted as a pulse. The IrDA encoder/decoder doesn't work when PSC=0.
- The receiver can communicate with a low-power transmitter.
- In IrDA mode, the STOP bits in the USART\_CR2 register must be configured to "1 stop bit".

**IrDA low-power mode**

**Transmitter:**

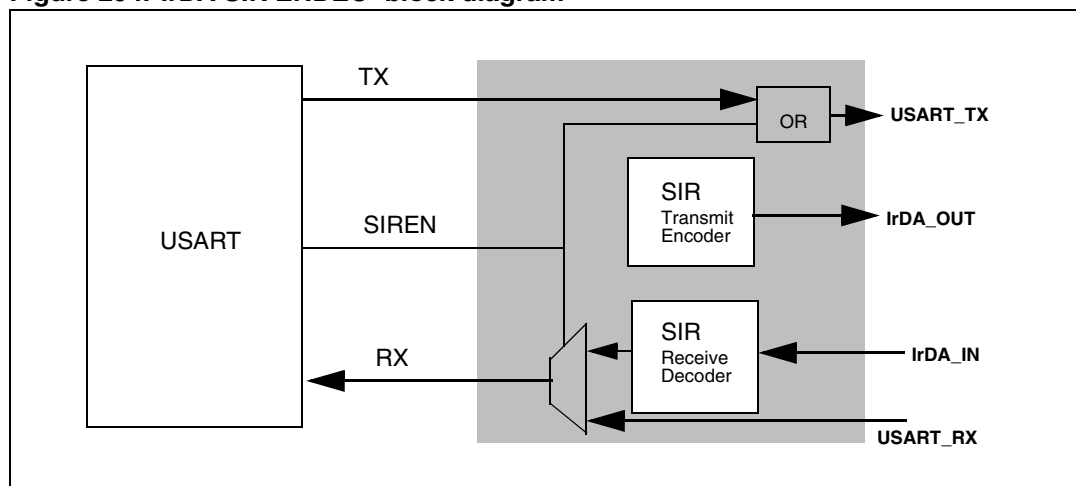
In low-power mode the pulse width is not maintained at 3/16 of the bit period. Instead, the width of the pulse is 3 times the low-power baud rate which can be a minimum of 1.42 MHz. Generally this value is 1.8432 MHz (1.42 MHz < PSC < 2.12 MHz). A low-power mode programmable divisor divides the system clock to achieve this value.

**Receiver:**

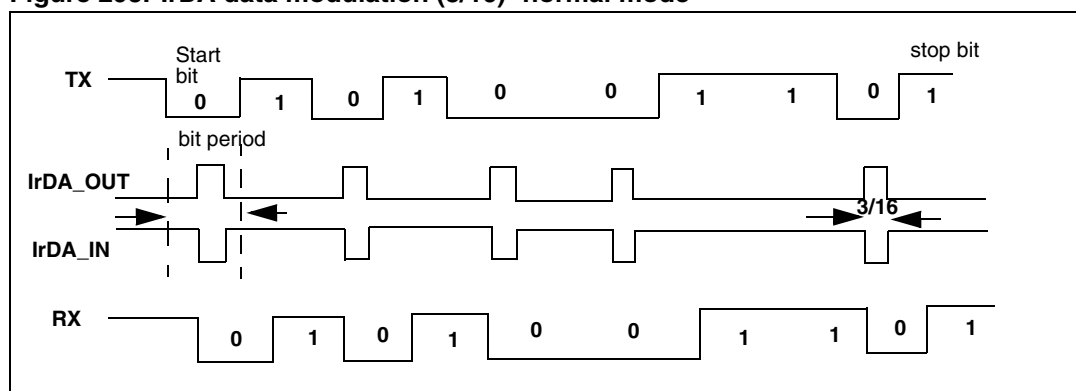
Receiving in low-power mode is similar to receiving in normal mode. For glitch detection the USART should discard pulses of duration shorter than 1/PSC. A valid low is accepted only if its duration is greater than 2 periods of the IrDA low-power Baud clock (PSC value in USART\_GTPR).

- Note:*
- 1 A pulse of width less than two and greater than one PSC period(s) may or may not be rejected.
  - 2 The receiver set up time should be managed by software. The IrDA physical layer specification specifies a minimum of 10 ms delay between transmission and reception (IrDA is a half duplex protocol).

**Figure 294. IrDA SIR ENDEC- block diagram**



**Figure 295. IrDA data modulation (3/16) -normal mode**





### 26.3.13 Continuous communication using DMA

The USART is capable to continue communication using the DMA. The DMA requests for Rx buffer and Tx buffer are generated independently.

*Note:* You should refer to product specs for availability of the DMA controller. If DMA is not available in the product, you should use the USART as explained in [Section 26.3.2](#) or [26.3.3](#). In the USART\_SR register, you can clear the TXE/ RXNE flags to achieve continuous communication.

#### Transmission using DMA

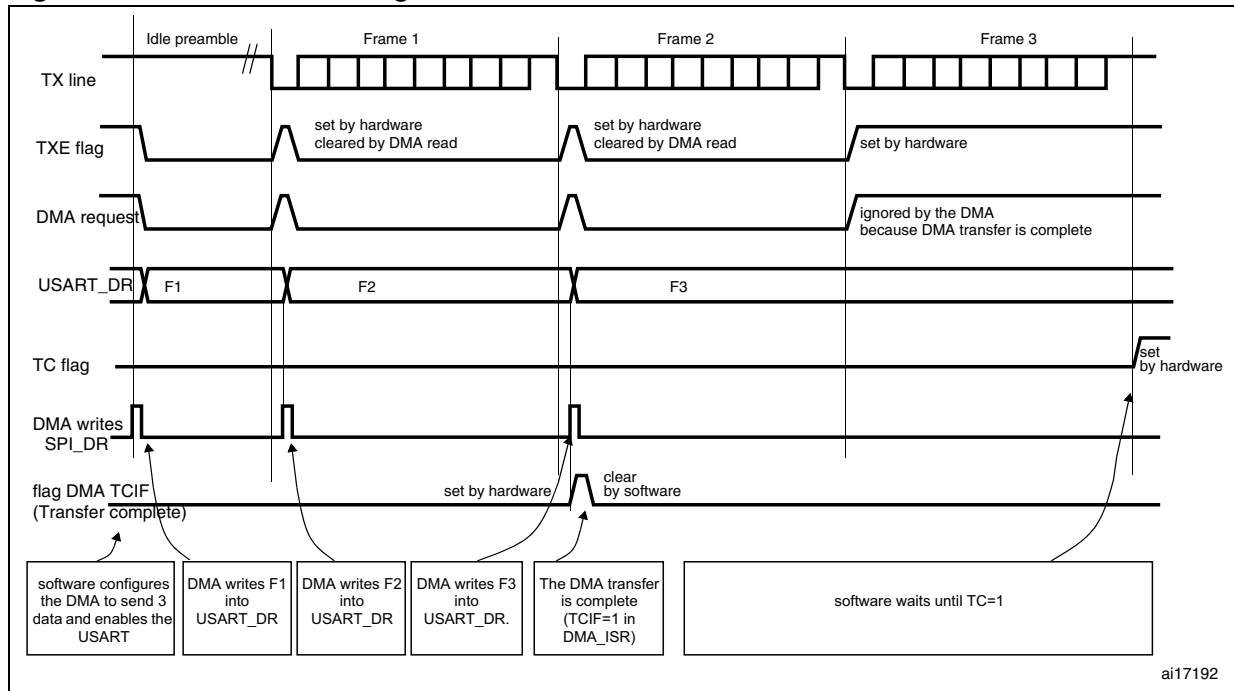
DMA mode can be enabled for transmission by setting DMAT bit in the USART\_CR3 register. Data is loaded from a SRAM area configured using the DMA peripheral (refer to the DMA specification) to the USART\_DR register whenever the TXE bit is set. To map a DMA channel for USART transmission, use the following procedure (x denotes the channel number):

1. Write the USART\_DR register address in the DMA control register to configure it as the destination of the transfer. The data will be moved to this address from memory after each TXE event.
2. Write the memory address in the DMA control register to configure it as the source of the transfer. The data will be loaded into the USART\_DR register from this memory area after each TXE event.
3. Configure the total number of bytes to be transferred to the DMA control register.
4. Configure the channel priority in the DMA register
5. Configure DMA interrupt generation after half/ full transfer as required by the application.
6. Clear the TC bit in the SR register by writing 0 to it.
7. Activate the channel in the DMA register.

When the number of data transfers programmed in the DMA Controller is reached, the DMA controller generates an interrupt on the DMA channel interrupt vector.

In transmission mode, once the DMA has written all the data to be transmitted (the TCIF flag is set in the DMA\_ISR register), the TC flag can be monitored to make sure that the USART communication is complete. This is required to avoid corrupting the last transmission before disabling the USART or entering the Stop mode. The software must wait until TC=1. The TC flag remains cleared during all data transfers and it is set by hardware at the last frame's end of transmission.

Figure 296. Transmission using DMA



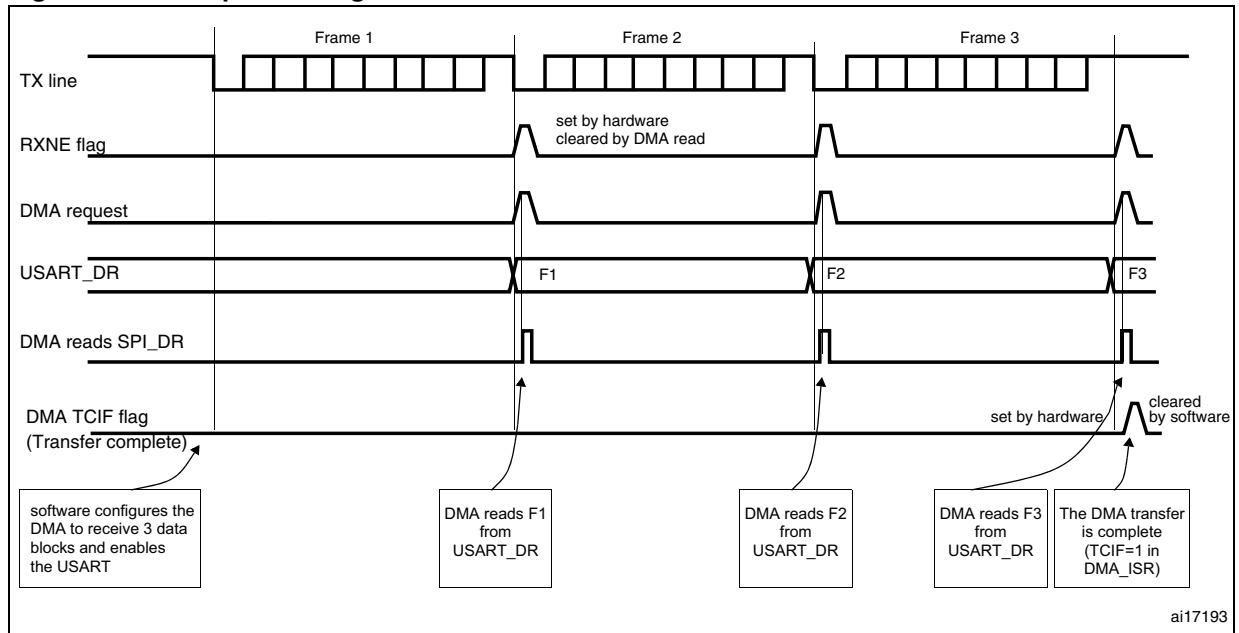
### Reception using DMA

DMA mode can be enabled for reception by setting the DMAR bit in USART\_CR3 register. Data is loaded from the USART\_DR register to a SRAM area configured using the DMA peripheral (refer to the DMA specification) whenever a data byte is received. To map a DMA channel for USART reception, use the following procedure:

1. Write the USART\_DR register address in the DMA control register to configure it as the source of the transfer. The data will be moved from this address to the memory after each RXNE event.
2. Write the memory address in the DMA control register to configure it as the destination of the transfer. The data will be loaded from USART\_DR to this memory area after each RXNE event.
3. Configure the total number of bytes to be transferred in the DMA control register.
4. Configure the channel priority in the DMA control register
5. Configure interrupt generation after half/ full transfer as required by the application.
6. Activate the channel in the DMA control register.

When the number of data transfers programmed in the DMA Controller is reached, the DMA controller generates an interrupt on the DMA channel interrupt vector.

Figure 297. Reception using DMA



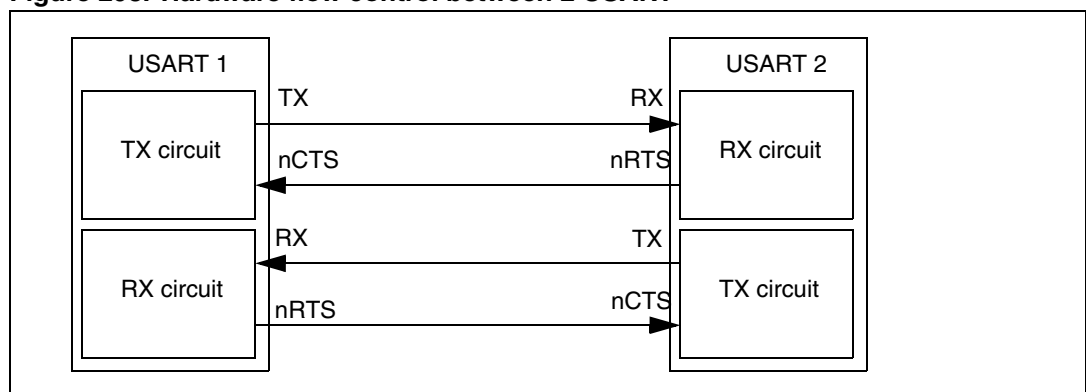
### Error flagging and interrupt generation in multibuffer communication

In case of multibuffer communication if any error occurs during the transaction the error flag will be asserted after the current byte. An interrupt will be generated if the interrupt enable flag is set. For framing error, overrun error and noise flag which are asserted with RXNE in case of single byte reception, there will be separate error flag interrupt enable bit (EIE bit in the USART\_CR3 register), which if set will issue an interrupt after the current byte with either of these errors.

### 26.3.14 Hardware flow control

It is possible to control the serial data flow between 2 devices by using the nCTS input and the nRTS output. The [Figure 298](#) shows how to connect 2 devices in this mode:

Figure 298. Hardware flow control between 2 USART

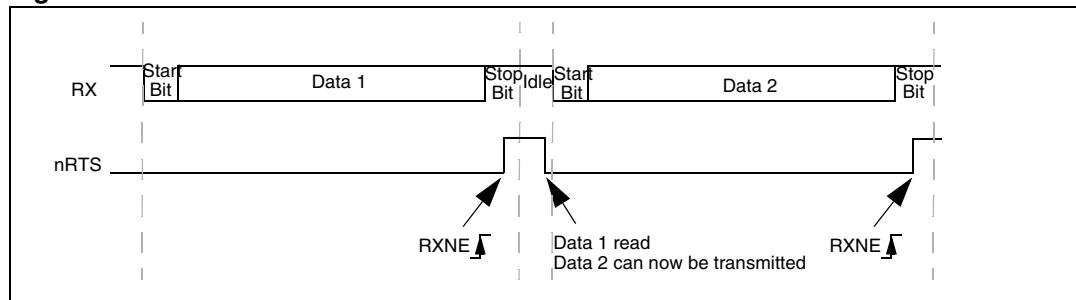


RTS and CTS flow control can be enabled independently by writing respectively RTSE and CTSE bits to 1 (in the USART\_CR3 register).

### RTS flow control

If the RTS flow control is enabled (RTSE=1), then nRTS is asserted (tied low) as long as the USART receiver is ready to receive new data. When the receive register is full, nRTS is deasserted, indicating that the transmission is expected to stop at the end of the current frame. *Figure 299* shows an example of communication with RTS flow control enabled.

**Figure 299. RTS flow control**

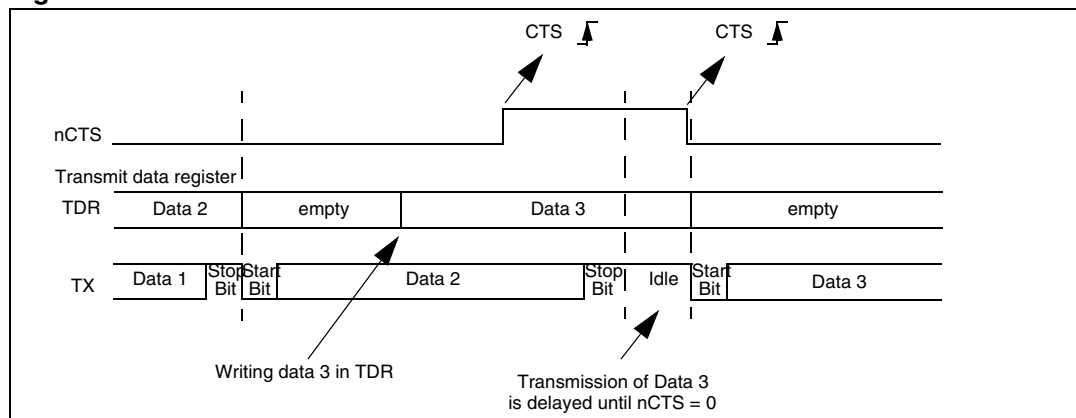


### CTS flow control

If the CTS flow control is enabled (CTSE=1), then the transmitter checks the nCTS input before transmitting the next frame. If nCTS is asserted (tied low), then the next data is transmitted (assuming that a data is to be transmitted, in other words, if TXE=0), else the transmission does not occur. When nCTS is deasserted during a transmission, the current transmission is completed before the transmitter stops.

When CTSE=1, the CTSIF status bit is automatically set by hardware as soon as the nCTS input toggles. It indicates when the receiver becomes ready or not ready for communication. An interrupt is generated if the CTSIE bit in the USART\_CR3 register is set. The figure below shows an example of communication with CTS flow control enabled.

**Figure 300. CTS flow control**



## 26.4 USART interrupts

**Table 193. USART interrupt requests**

Interrupt event	Event flag	Enable Control bit
Transmit data register empty	TXE	TXEIE
CTS flag	CTS	CTSIE
Transmission complete	TC	TCIE
Received data ready to be read	RXNE	RXNEIE
Overrun error detected	ORE	
Idle line detected	IDLE	IDLEIE
Parity error	PE	PEIE
Break flag	LBD	LBDIE
Noise flag, Overrun error and Framing error in multibuffer communication	NE or ORE or FE	EIE <sup>(1)</sup>

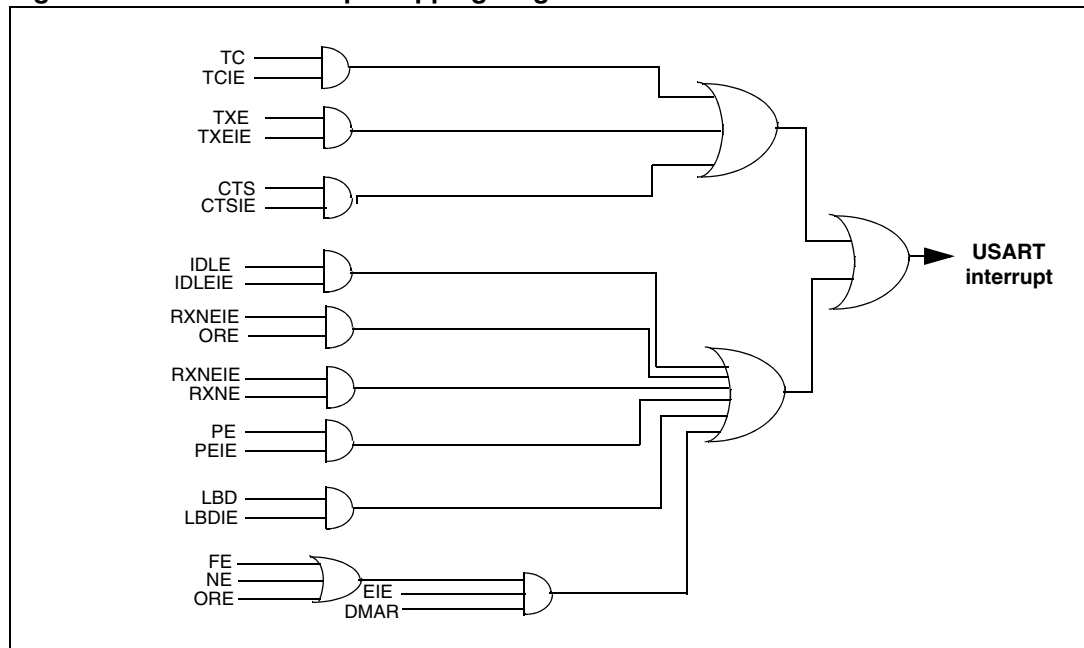
1. This bit is used only when data reception is performed by DMA.

The USART interrupt events are connected to the same interrupt vector (see [Figure 301](#)).

- During transmission: Transmission Complete, Clear to Send or Transmit Data Register empty interrupt.
- While receiving: Idle Line detection, Overrun error, Receive Data register not empty, Parity error, LIN break detection, Noise Flag (only in multi buffer communication) and Framing Error (only in multi buffer communication).

These events generate an interrupt if the corresponding Enable Control Bit is set.

**Figure 301. USART interrupt mapping diagram**



## 26.5 USART mode configuration

Table 194. USART mode configuration<sup>(1)</sup>

USART modes	USART1	USART2	USART3	UART4	UART5
Asynchronous mode	X	X	X	X	X
Hardware Flow Control	X	X	X	NA	NA
Multibuffer Communication (DMA)	X	X	X	X	NA
Multiprocessor Communication	X	X	X	X	X
Synchronous	X	X	X	NA	NA
Smartcard	X	X	X	NA	NA
Half-Duplex (Single-Wire mode)	X	X	X	X	X
IrDA	X	X	X	X	X
LIN	X	X	X	X	X

1. X = supported; NA = not applicable.

## 26.6 USART registers

Refer to [Section 1.1 on page 40](#) for a list of abbreviations used in register descriptions.

The peripheral registers can be accessed by half-words (16-bit) or words (32-bit).

### 26.6.1 Status register (USART\_SR)

Address offset: 0x00

Reset value: 0x00C0

31	30	29	28	27	26	25	24	23	22	21	20	19	18	17	16
Reserved															
15	14	13	12	11	10	9	8	7	6	5	4	3	2	1	0
Reserved						CTS	LBD	TXE	TC	RXNE	IDLE	ORE	NE	FE	PE
Res.						rc_w0	rc_w0	r	rc_w0	rc_w0	r	r	r	r	r

Bits 31:10 Reserved, forced by hardware to 0.

Bit 9 **CTS**: CTS flag

This bit is set by hardware when the nCTS input toggles, if the CTSE bit is set. It is cleared by software (by writing it to 0). An interrupt is generated if CTSIE=1 in the USART\_CR3 register.

0: No change occurred on the nCTS status line

1: A change occurred on the nCTS status line

This bit is not available for UART4 & UART5.

**Bit 8 LBD:** LIN break detection flag

This bit is set by hardware when the LIN break is detected. It is cleared by software (by writing it to 0). An interrupt is generated if LBDIE = 1 in the USART\_CR2 register.

- 0: LIN Break not detected
- 1: LIN break detected

*Note: An interrupt is generated when LBD=1 if LBDIE=1*

**Bit 7 TXE:** Transmit data register empty

This bit is set by hardware when the content of the TDR register has been transferred into the shift register. An interrupt is generated if the TXEIE bit =1 in the USART\_CR1 register. It is cleared by a write to the USART\_DR register.

- 0: Data is not transferred to the shift register
- 1: Data is transferred to the shift register)

*Note: This bit is used during single buffer transmission.*

**Bit 6 TC:** Transmission complete

This bit is set by hardware if the transmission of a frame containing data is complete and if TXE is set. An interrupt is generated if TCIE=1 in the USART\_CR1 register. It is cleared by a software sequence (a read from the USART\_SR register followed by a write to the USART\_DR register). The TC bit can also be cleared by writing a '0' to it. This clearing sequence is recommended only for multibuffer communication.

- 0: Transmission is not complete
- 1: Transmission is complete

**Bit 5 RXNE:** Read data register not empty

This bit is set by hardware when the content of the RDR shift register has been transferred to the USART\_DR register. An interrupt is generated if RXNEIE=1 in the USART\_CR1 register. It is cleared by a read to the USART\_DR register. The RXNE flag can also be cleared by writing a zero to it. This clearing sequence is recommended only for multibuffer communication.

- 0: Data is not received
- 1: Received data is ready to be read.

**Bit 4 IDLE:** IDLE line detected

This bit is set by hardware when an Idle Line is detected. An interrupt is generated if the IDLEIE=1 in the USART\_CR1 register. It is cleared by a software sequence (an read to the USART\_SR register followed by a read to the USART\_DR register).

- 0: No Idle Line is detected
- 1: Idle Line is detected

*Note: The IDLE bit will not be set again until the RXNE bit has been set itself (i.e. a new idle line occurs).*

**Bit 3 ORE:** Overrun error

This bit is set by hardware when the word currently being received in the shift register is ready to be transferred into the RDR register while RXNE=1. An interrupt is generated if RXNEIE=1 in the USART\_CR1 register. It is cleared by a software sequence (an read to the USART\_SR register followed by a read to the USART\_DR register).

- 0: No Overrun error
- 1: Overrun error is detected

*Note: When this bit is set, the RDR register content will not be lost but the shift register will be overwritten. An interrupt is generated on ORE flag in case of Multi Buffer communication if the EIE bit is set.*

Bit 2 **NE**: Noise error flag

This bit is set by hardware when noise is detected on a received frame. It is cleared by a software sequence (an read to the USART\_SR register followed by a read to the USART\_DR register).

0: No noise is detected

1: Noise is detected

*Note: This bit does not generate interrupt as it appears at the same time as the RXNE bit which itself generates an interrupting interrupt is generated on NE flag in case of Multi Buffer communication if the EIE bit is set.*

Bit 1 **FE**: Framing error

This bit is set by hardware when a de-synchronization, excessive noise or a break character is detected. It is cleared by a software sequence (an read to the USART\_SR register followed by a read to the USART\_DR register).

0: No Framing error is detected

1: Framing error or break character is detected

*Note: This bit does not generate interrupt as it appears at the same time as the RXNE bit which itself generates an interrupt. If the word currently being transferred causes both frame error and overrun error, it will be transferred and only the ORE bit will be set.*

*An interrupt is generated on FE flag in case of Multi Buffer communication if the EIE bit is set.*

Bit 0 **PE**: Parity error

This bit is set by hardware when a parity error occurs in receiver mode. It is cleared by a software sequence (a read to the status register followed by a read to the USART\_DR data register). The software must wait for the RXNE flag to be set before clearing the PE bit.

An interrupt is generated if PEIE = 1 in the USART\_CR1 register.

0: No parity error

1: Parity error

### 26.6.2 Data register (USART\_DR)

Address offset: 0x04

Reset value: Undefined

31	30	29	28	27	26	25	24	23	22	21	20	19	18	17	16
Reserved															
15	14	13	12	11	10	9	8	7	6	5	4	3	2	1	0
Reserved							DR[8:0]								
Res.							rw	rw	rw	rw	rw	rw	rw	rw	rw

Bits 31:9 Reserved, forced by hardware to 0.



Bits 8:0 **DR[8:0]**: Data value

Contains the Received or Transmitted data character, depending on whether it is read from or written to.

The Data register performs a double function (read and write) since it is composed of two registers, one for transmission (TDR) and one for reception (RDR)

The TDR register provides the parallel interface between the internal bus and the output shift register (see Figure 1).

The RDR register provides the parallel interface between the input shift register and the internal bus.

When transmitting with the parity enabled (PCE bit set to 1 in the USART\_CR1 register), the value written in the MSB (bit 7 or bit 8 depending on the data length) has no effect because it is replaced by the parity.

When receiving with the parity enabled, the value read in the MSB bit is the received parity bit.

### 26.6.3 Baud rate register (USART\_BRR)

*Note: The baud counters stop counting if the TE or RE bits are disabled respectively.*

Address offset: 0x08

Reset value: 0x0000

31	30	29	28	27	26	25	24	23	22	21	20	19	18	17	16
Reserved															
15	14	13	12	11	10	9	8	7	6	5	4	3	2	1	0
DIV_Mantissa[11:0]												DIV_Fraction[3:0]			
rw	rw	rw	rw	rw	rw	rw	rw	rw	rw	rw	rw	rw	rw	rw	rw

Bits 31:16 Reserved, forced by hardware to 0.

Bits 15:4 **DIV\_Mantissa[11:0]**: mantissa of USARTDIV

These 12 bits define the mantissa of the USART Divider (USARTDIV)

Bits 3:0 **DIV\_Fraction[3:0]**: fraction of USARTDIV

These 4 bits define the fraction of the USART Divider (USARTDIV)

### 26.6.4 Control register 1 (USART\_CR1)

Address offset: 0x0C

Reset value: 0x0000

31	30	29	28	27	26	25	24	23	22	21	20	19	18	17	16
Reserved															
15	14	13	12	11	10	9	8	7	6	5	4	3	2	1	0
Reserved	UE	M	WAKE	PCE	PS	PEIE	TXEIE	TCIE	RXNEIE	IDLEIE	TE	RE	RWU	SBK	
Res.	rw	rw	rw	rw	rw	rw	rw	rw	rw	rw	rw	rw	rw	rw	

Bits 31:14 Reserved, forced by hardware to 0.

Bit 13 **UE**: USART enable

When this bit is cleared the USART prescalers and outputs are stopped and the end of the current

byte transfer in order to reduce power consumption. This bit is set and cleared by software.

0: USART prescaler and outputs disabled

1: USART enabled

Bit 12 **M**: Word length

This bit determines the word length. It is set or cleared by software.

0: 1 Start bit, 8 Data bits, n Stop bit

1: 1 Start bit, 9 Data bits, n Stop bit

*Note: The M bit must not be modified during a data transfer (both transmission and reception)*

Bit 11 **WAKE**: Wakeup method

This bit determines the USART wakeup method, it is set or cleared by software.

0: Idle Line

1: Address Mark

Bit 10 **PCE**: Parity control enable

This bit selects the hardware parity control (generation and detection). When the parity control is enabled, the computed parity is inserted at the MSB position (9th bit if M=1; 8th bit if M=0) and parity is checked on the received data. This bit is set and cleared by software.

Once it is set, PCE is active after the current byte (in reception and in transmission).

0: Parity control disabled

1: Parity control enabled

Bit 9 **PS**: Parity selection

This bit selects the odd or even parity when the parity generation/detection is enabled (PCE bit set). It is set and cleared by software. The parity will be selected after the current byte.

0: Even parity

1: Odd parity

Bit 8 **PEIE**: PE interrupt enable

This bit is set and cleared by software.

0: Interrupt is inhibited

1: An USART interrupt is generated whenever PE=1 in the USART\_SR register

Bit 7 **TXEIE**: TXE interrupt enable

This bit is set and cleared by software.

0: Interrupt is inhibited

1: An USART interrupt is generated whenever TXE=1 in the USART\_SR register

- Bit 6 **TCIE**: Transmission complete interrupt enable  
This bit is set and cleared by software.  
0: Interrupt is inhibited  
1: An USART interrupt is generated whenever TC=1 in the USART\_SR register
- Bit 5 **RXNEIE**: RXNE interrupt enable  
This bit is set and cleared by software.  
0: Interrupt is inhibited  
1: An USART interrupt is generated whenever ORE=1 or RXNE=1 in the USART\_SR register
- Bit 4 **IDLEIE**: IDLE interrupt enable  
This bit is set and cleared by software.  
0: Interrupt is inhibited  
1: An USART interrupt is generated whenever IDLE=1 in the USART\_SR register
- Bit 3 **TE**: Transmitter enable  
This bit enables the transmitter. It is set and cleared by software.  
0: Transmitter is disabled  
1: Transmitter is enabled  
*Note:* 1: During transmission, a “0” pulse on the TE bit (“0” followed by “1”) sends a preamble (idle line) after the current word, except in smartcard mode.  
2: When TE is set there is a 1 bit-time delay before the transmission starts.
- Bit 2 **RE**: Receiver enable  
This bit enables the receiver. It is set and cleared by software.  
0: Receiver is disabled  
1: Receiver is enabled and begins searching for a start bit
- Bit 1 **RWU**: Receiver wakeup  
This bit determines if the USART is in mute mode or not. It is set and cleared by software and can be cleared by hardware when a wakeup sequence is recognized.  
0: Receiver in active mode  
1: Receiver in mute mode  
*Note:* 1: Before selecting Mute mode (by setting the RWU bit) the USART must first receive a data byte, otherwise it cannot function in Mute mode with wakeup by Idle line detection.  
2: In Address Mark Detection wakeup configuration (WAKE bit=1) the RWU bit cannot be modified by software while the RXNE bit is set.
- Bit 0 **SBK**: Send break  
This bit set is used to send break characters. It can be set and cleared by software. It should be set by software, and will be reset by hardware during the stop bit of break.  
0: No break character is transmitted  
1: Break character will be transmitted

### 26.6.5 Control register 2 (USART\_CR2)

Address offset: 0x10

Reset value: 0x0000

31	30	29	28	27	26	25	24	23	22	21	20	19	18	17	16
Reserved															
15	14	13	12	11	10	9	8	7	6	5	4	3	2	1	0
Res.	LINEN	STOP[1:0]		CLK EN	CPOL	CPHA	LBCL	Res.	LBDIE	LBDL	Res.	ADD[3:0]			
	rw	rw	rw	rw	rw	rw	rw		rw	rw	rw	rw	rw	rw	rw

Bits 31:15 Reserved, forced by hardware to 0.

Bit 14 **LINEN**: LIN mode enable

This bit is set and cleared by software.

0: LIN mode disabled

1: LIN mode enabled

The LIN mode enables the capability to send LIN Synch Breaks (13 low bits) using the SBK bit in the USART\_CR1 register, and to detect LIN Sync breaks.

Bits 13:12 **STOP**: STOP bits

These bits are used for programming the stop bits.

00: 1 Stop bit

01: 0.5 Stop bit

10: 2 Stop bits

11: 1.5 Stop bit

The 0.5 Stop bit and 1.5 Stop bit are not available for UART4 & UART5.

Bit 11 **CLKEN**: Clock enable

This bit allows the user to enable the CK pin.

0: CK pin disabled

1: CK pin enabled

This bit is not available for UART4 & UART5.

Bit 10 **CPOL**: Clock polarity

This bit allows the user to select the polarity of the clock output on the CK pin in synchronous mode. It works in conjunction with the CPHA bit to produce the desired clock/data relationship

0: Steady low value on CK pin outside transmission window.

1: Steady high value on CK pin outside transmission window.

This bit is not available for UART4 & UART5.

Bit 9 **CPHA**: Clock phase

This bit allows the user to select the phase of the clock output on the CK pin in synchronous mode. It works in conjunction with the CPOL bit to produce the desired clock/data relationship (see figures 289 to 290)

0: The first clock transition is the first data capture edge.

1: The second clock transition is the first data capture edge.

This bit is not available for UART4 & UART5.

Bit 8 **LBCL**: Last bit clock pulse

This bit allows the user to select whether the clock pulse associated with the last data bit transmitted (MSB) has to be output on the CK pin in synchronous mode.

0: The clock pulse of the last data bit is not output to the CK pin

1: The clock pulse of the last data bit is output to the CK pin

The last bit is the 8th or 9th data bit transmitted depending on the 8 or 9 bit format selected by the M bit in the USART\_CR1 register.

This bit is not available for UART4 & UART5.

Bit 7 Reserved, forced by hardware to 0.

Bit 6 **LBDIE**: LIN break detection interrupt enable

Break interrupt mask (break detection using break delimiter).

0: Interrupt is inhibited

1: An interrupt is generated whenever LBD=1 in the USART\_SR register

Bit 5 **LBDL**: *lin* break detection length

This bit is for selection between 11 bit or 10 bit break detection.

0: 10 bit break detection

1: 11 bit break detection

Bit 4 Reserved, forced by hardware to 0.

Bits 3:0 **ADD[3:0]**: Address of the USART node

This bit-field gives the address of the USART node.

This is used in multiprocessor communication during mute mode, for wake up with address mark detection.

*Note: These 3 bits (CPOL, CPHA, LBCL) should not be written while the transmitter is enabled.*

### 26.6.6 Control register 3 (USART\_CR3)

Address offset: 0x14

Reset value: 0x0000

31	30	29	28	27	26	25	24	23	22	21	20	19	18	17	16
Reserved															
15	14	13	12	11	10	9	8	7	6	5	4	3	2	1	0
Reserved				CTSIE	CTSE	RTSE	DMAT	DMAR	SCEN	NACK	HDSEL	IRLP	IREN	EIE	
Res.				rw	rw	rw	rw	rw	rw	rw	rw	rw	rw	rw	rw

Bits 31:11 Reserved, forced by hardware to 0.

Bit 10 **CTSIE**: CTS interrupt enable

0: Interrupt is inhibited

1: An interrupt is generated whenever CTS=1 in the USART\_SR register

This bit is not available for UART4 & UART5.

Bit 9 **CTSE**: CTS enable

0: CTS hardware flow control disabled

1: CTS mode enabled, data is only transmitted when the nCTS input is asserted (tied to 0). If the nCTS input is deasserted while a data is being transmitted, then the transmission is completed before stopping. If a data is written into the data register while nCTS is asserted, the transmission is postponed until nCTS is asserted.

This bit is not available for UART4 & UART5.

- Bit 8 **RTSE**: RTS enable  
0: RTS hardware flow control disabled  
1: RTS interrupt enabled, data is only requested when there is space in the receive buffer. The transmission of data is expected to cease after the current character has been transmitted. The nRTS output is asserted (tied to 0) when a data can be received.  
This bit is not available for UART4 & UART5.
- Bit 7 **DMAT**: DMA enable transmitter  
This bit is set/reset by software  
1: DMA mode is enabled for transmission  
0: DMA mode is disabled for transmission  
This bit is not available for UART5.
- Bit 6 **DMAR**: DMA enable receiver  
This bit is set/reset by software  
1: DMA mode is enabled for reception  
0: DMA mode is disabled for reception  
This bit is not available for UART5.
- Bit 5 **SCEN**: Smartcard mode enable  
This bit is used for enabling Smartcard mode.  
0: Smartcard Mode disabled  
1: Smartcard Mode enabled  
This bit is not available for UART4 & UART5.
- Bit 4 **NACK**: Smartcard NACK enable  
0: NACK transmission in case of parity error is disabled  
1: NACK transmission during parity error is enabled  
This bit is not available for UART4 & UART5.
- Bit 3 **HDSEL**: Half-duplex selection  
Selection of Single-wire Half-duplex mode  
0: Half duplex mode is not selected  
1: Half duplex mode is selected
- Bit 2 **IRLP**: IrDA low-power  
This bit is used for selecting between normal and low-power IrDA modes  
0: Normal mode  
1: Low-power mode
- Bit 1 **IREN**: IrDA mode enable  
This bit is set and cleared by software.  
0: IrDA disabled  
1: IrDA enabled
- Bit 0 **EIE**: Error interrupt enable  
Error Interrupt Enable Bit is required to enable interrupt generation in case of a framing error, overrun error or noise error (FE=1 or ORE=1 or NE=1 in the USART\_SR register) in case of Multi Buffer Communication (DMAR=1 in the USART\_CR3 register).  
0: Interrupt is inhibited  
1: An interrupt is generated whenever DMAR=1 in the USART\_CR3 register and FE=1 or ORE=1 or NE=1 in the USART\_SR register.

### 26.6.7 Guard time and prescaler register (USART\_GTPR)

Address offset: 0x18

Reset value: 0x0000

31	30	29	28	27	26	25	24	23	22	21	20	19	18	17	16
Reserved															
15	14	13	12	11	10	9	8	7	6	5	4	3	2	1	0
GT[7:0]								PSC[7:0]							
rw	rw	rw	rw	rw	rw	rw	rw	rw	rw	rw	rw	rw	rw	rw	rw

Bits 31:16 Reserved, forced by hardware to 0.

Bits 15:8 **GT[7:0]**: Guard time value

This bit-field gives the Guard time value in terms of number of baud clocks.

This is used in Smartcard mode. The Transmission Complete flag is set after this guard time value.

This bit is not available for UART4 & UART5.

Bits 7:0 **PSC[7:0]**: Prescaler value

– In IrDA Low-power mode:

**PSC[7:0]** = IrDA Low-Power Baud Rate

Used for programming the prescaler for dividing the system clock to achieve the low-power frequency:

The source clock is divided by the value given in the register (8 significant bits):

00000000: Reserved - do not program this value

00000001: divides the source clock by 1

00000010: divides the source clock by 2

...

– In normal IrDA mode: PSC must be set to 00000001.

– In smartcard mode:

**PSC[4:0]**: Prescaler value

Used for programming the prescaler for dividing the system clock to provide the smartcard clock.

The value given in the register (5 significant bits) is multiplied by 2 to give the division factor of the source clock frequency:

00000: Reserved - do not program this value

00001: divides the source clock by 2

00010: divides the source clock by 4

00011: divides the source clock by 6

...

Bits [7:5] have no effect if Smartcard mode is used.

This bit is not available for UART4 & UART5.

### 26.6.8 USART register map

The table below gives the USART register map and reset values.

**Table 195. USART register map and reset values**

Offset	Register	31	30	29	28	27	26	25	24	23	22	21	20	19	18	17	16	15	14	13	12	11	10	9	8	7	6	5	4	3	2	1	0						
0x00	USART_SR	Reserved																						CTS	LBD	TXE	TC	RXNE	IDLE	ORE	NE	FE	PE						
	Reset value																							0	0	1	1	0	0	0	0	0	0						
0x04	USART_DR	Reserved																						DR[8:0]															
	Reset value																							0	0	0	0	0	0	0	0	0	0						
0x08	USART_BRR	Reserved														DIV_Mantissa[15:4]						DIV_Fraction [3:0]																	
	Reset value															0	0	0	0	0	0	0	0	0	0	0	0	0	0	0	0	0							
0x0C	USART_CR1	Reserved														UE	M	WAKE	PCE	PS	PEIE	TXEIE	TCIE	RXNEIE	IDLEIE	TE	RE	FWU	SBK										
	Reset value															0	0	0	0	0	0	0	0	0	0	0	0	0	0	0	0	0	0						
0x10	USART_CR2	Reserved											LINEN	STOP [1:0]	CLKEN	CPOL	CPHA	LBCL	LBDIE	LBDL	Reserved	ADD[3:0]																	
	Reset value												0	0	0	0	0	0	0	0	0	0	0	0	0	0	0	0	0										
0x14	USART_CR3	Reserved														CTSIE	CTSE	RTSE	DMAT	DMAR	SCEN	NACK	HDSEL	IRLP	IREN	EIE													
	Reset value															0	0	0	0	0	0	0	0	0	0	0	0	0	0	0	0	0							
0x18	USART_GTPR	Reserved														GT[7:0]						PSC[7:0]																	
	Reset value															0	0	0	0	0	0	0	0	0	0	0	0	0	0	0	0	0							

Refer to [Table 1 on page 44](#) for the register boundary addresses.



## 27 USB on-the-go full-speed (OTG\_FS)

**Low-density devices** are STM32F101xx, STM32F102xx and STM32F103xx microcontrollers where the Flash memory density ranges between 16 and 32 Kbytes.

**Medium-density devices** are STM32F101xx, STM32F102xx and STM32F103xx microcontrollers where the Flash memory density ranges between 64 and 128 Kbytes.

**High-density devices** are STM32F101xx and STM32F103xx microcontrollers where the Flash memory density ranges between 256 and 512 Kbytes.

**XL-density devices** are STM32F101xx and STM32F103xx microcontrollers where the Flash memory density ranges between 768 Kbytes and 1 Mbyte.

**Connectivity line devices** are STM32F105xx and STM32F107xx microcontrollers.

This section applies only to STM32F105xx and STM32F107xx connectivity line devices.

### 27.1 OTG\_FS introduction

Portions Copyright (c) 2004, 2005 Synopsys, Inc. All rights reserved. Used with permission.

This section presents the architecture and the programming model of the OTG\_FS controller.

The following acronyms are used throughout the section:

FS	full-speed
LS	Low-speed
MAC	Media access controller
OTG	On-the-go
PFC	Packet FIFO controller
PHY	Physical layer
USB	Universal serial bus
UTMI	USB 2.0 transceiver macrocell interface (UTMI)

References are made to the following documents:

- USB On-The-Go Supplement, Revision 1.3
- Universal Serial Bus Revision 2.0 Specification

The OTG\_FS is a dual-role device (DRD) controller that supports both device and host functions and is fully compliant with the *On-The-Go Supplement to the USB 2.0 Specification*. It can also be configured as a host-only or device-only controller, fully compliant with the *USB 2.0 Specification*. In host mode, the OTG\_FS supports full-speed (FS, 12 Mbits/s) and low-speed (LS, 1.5 Mbits/s) transfers whereas in device mode, it only supports full-speed (FS, 12 Mbits/s) transfers. The OTG\_FS supports both HNP and SRP. The only external device required is a charge pump for  $V_{BUS}$  in Host mode.

## 27.2 OTG\_FS main features

The main features can be divided into three categories: general, host-mode and device-mode features.

### 27.2.1 General features

The OTG\_FS interface:

- is USB-IF certified to the Universal Serial Bus Specification Rev 2.0
- includes full support (PHY) for the optional On-The-Go (OTG) protocol detailed in the On-The-Go Supplement Rev 1.3 specification
  - integrated support for A-B Device Identification (ID line)
  - integrated support for Host Negotiation Protocol (HNP) and Session Request Protocol (SRP)
  - allows host to turn VBUS off to conserve battery power in OTG applications
  - supports OTG monitoring of VBUS levels with internal comparators
  - supports dynamic Host-Peripheral switch of role
- is software-configurable to operate as:
  - SRP capable USB FS Peripheral (B-Device)
  - SRP capable USB FS/LS Host (A-Device)
  - USB On-The-Go Full-Speed Dual Role Device
- supports FS SOF and LS Keep-alives with
  - SOF pulse PAD connectivity
  - SOF pulse internal connection to timer2 (TIM2)
  - configurable framing period
  - configurable end of frame interrupt
- includes power saving features such as system stop during USB Suspend, switch-off of clock domains internal to the digital core, PHY and DFIFO power management
- features a dedicated RAM of 1.25 Kbytes with advanced FIFO control:
  - configurable partitioning of RAM space into different FIFOs for flexible and efficient use of RAM
  - each FIFO can hold multiple packets
  - dynamic memory allocation
  - configurable FIFO sizes that are not powers of 2 to allow the use of contiguous memory locations
- guarantees max USB bandwidth for up to one frame (1ms) without system intervention

### 27.2.2 Host-mode features

The OTG\_FS interface:

- requires an external charge pump to generate the  $V_{BUS}$  voltage
- has up to 8 host channels (pipes) and each channel is dynamically reconfigurable to allocate any type of USB transfer
- has a built-in HW scheduler holding:
  - up to 8 interrupt plus isochronous transfer requests in the periodic hardware queue
  - up to 8 control plus bulk transfer requests in the non-periodic hardware queue
- manages a shared RX FIFO, a periodic TX FIFO and a nonperiodic TX FIFO for efficient usage of the USB data RAM

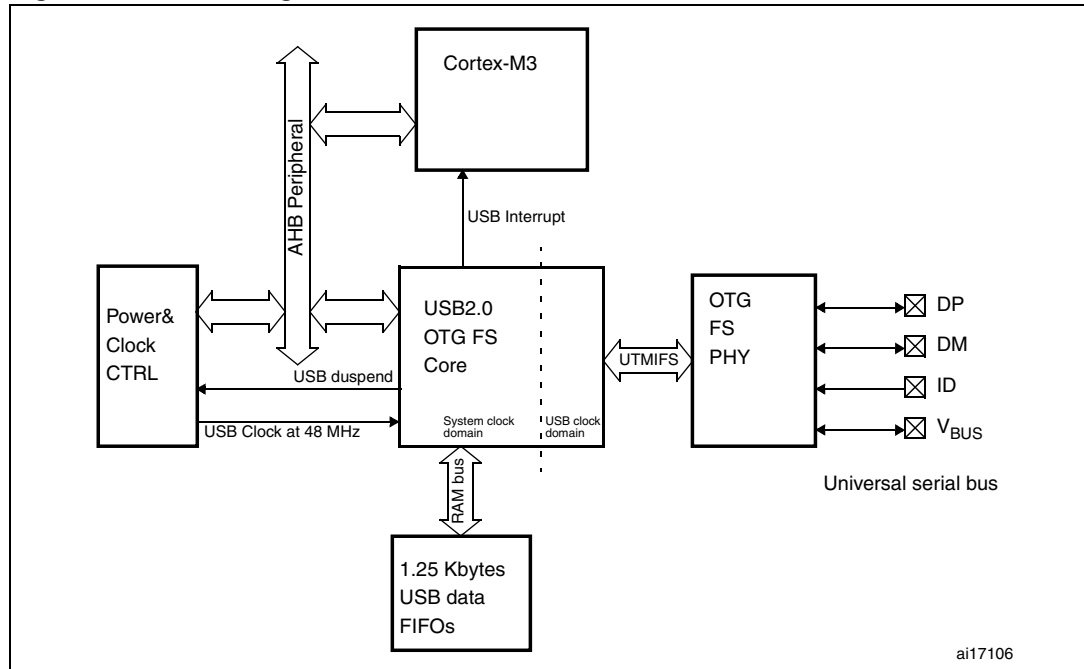
### 27.2.3 Peripheral-mode features

The OTG\_FS interface:

- has 1 bidirectional control endpoint0
- has 3 IN endpoints (EPs) configurable to support Bulk, Interrupt or Isochronous transfers
- has 3 OUT endpoints configurable to support Bulk, Interrupt or Isochronous transfers
- manages a shared Rx FIFO and a Tx-OUT FIFO for efficient usage of the USB data RAM
- manages up to 4 dedicated Tx-IN FIFOs (one for each active IN EP) to put less load on the application
- supports the soft disconnect feature

### 27.3 OTG\_FS functional description

Figure 302. Block diagram



#### 27.3.1 OTG full-speed core

The USB OTG FS receives the 48 MHz  $\pm 0.25\%$  clock from the reset and clock controller (RCC), via an external quartz. The USB clock is used for driving the 48 MHz domain at full-speed (12 Mbit/s) and must be enabled prior to configuring the OTG FS Core.

The CPU reads and writes from/to the OTG FS Core registers through the AHB peripheral bus. It is informed of USB events through the single USB OTG interrupt line described in [Section 27.14: OTG\\_FS interrupts](#).

The CPU submits data over the USB by writing 32-bit words to dedicated OTG\_FS locations (push registers). The data are then automatically stored into Tx-data FIFOs configured within the USB data RAM. There is one Tx-FIFO push register for each in-endpoint (peripheral mode) or out-channel (host mode).

The CPU receives the data from the USB by reading 32-bit words from dedicated OTG\_FS addresses (pop registers). The data are then automatically retrieved from a shared Rx-FIFO configured within the 1.25 KB USB data RAM. There is one Rx-FIFO pop register for each out-endpoint or in-channel.

The USB protocol layer is driven by the serial interface engine (SIE) and serialized over the USB by the full-/low-speed transceiver module within the on-chip physical layer (PHY).

#### 27.3.2 Full-speed OTG PHY

The embedded full-speed OTG PHY is controlled by the OTG FS Core and conveys USB control & data signals through the full-speed subset of the UTMI+ Bus (UTMIFS). It provides

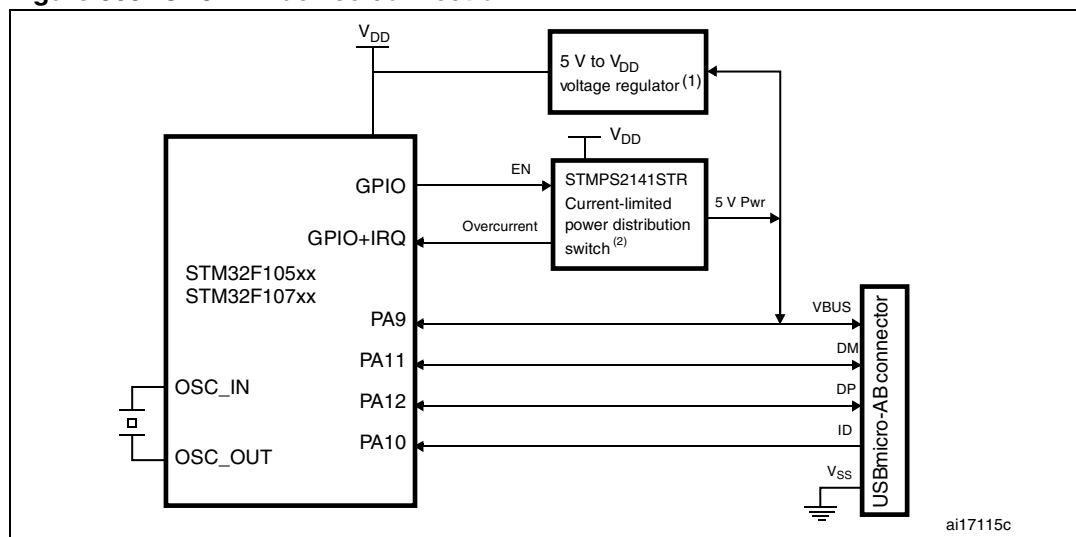
the physical support to USB connectivity.

The full-speed OTG PHY includes the following components:

- FS/LS transceiver module used by both Host and Device. It directly drives transmission and reception on the single-ended USB lines.
- integrated ID pull-up resistor used to sample the ID line for A/B Device identification.
- DP/DM integrated pull-up and pull-down resistors controlled by the OTG\_FS Core depending on the current role of the device. As a peripheral, it enables the DP pull-up resistor to signal full-speed peripheral connections as soon as  $V_{BUS}$  is sensed to be at a valid level (B-session valid). In Host mode, pull-down resistors are enabled on both DP/DM. Pull-up and pull-down resistors are dynamically switched when the device's role is changed via the host negotiation protocol (HNP).
- Pull-up/pull-down resistor ECN circuit. The DP pull-up consists of 2 resistors controlled separately from the OTG\_FS as per the resistor Engineering Change Notice applied to USB Rev2.0. The dynamic trimming of the DP pull-up strength allows for better noise rejection and Tx/Rx signal quality.
- $V_{BUS}$  sensing comparators with hysteresis used to detect  $V_{BUS}$  Valid, A-B Session Valid and session-end voltage thresholds. They are used to drive the session request protocol (SRP), detect valid startup and end-of-session conditions, and constantly monitor the  $V_{BUS}$  supply during USB operations.
- $V_{BUS}$  pulsing method circuit used to charge/discharge  $V_{BUS}$  through resistors during the SRP (weak drive).

## 27.4 OTG dual role device (DRD)

Figure 303. OTG A-B device connection



1. External voltage regulator only needed when building a  $V_{BUS}$  powered device
2. STMP2141STR needed only if the application has to support a  $V_{BUS}$  powered device. A basic power switch can be used if 5 V are available on the application board.

### 27.4.1 ID line detection

The Host or Peripheral (the default) role is assumed depending on the ID input pin. The ID line status is determined on plugging in the USB, depending on which side of the USB cable is connected to the micro-AB receptacle.

- If the B-side of the USB cable is connected with a floating ID wire, the integrated pull-up resistor detects a high ID level and the default Peripheral role is confirmed. In this configuration the OTG\_FS complies with the standard FSM described by section 6.8.2: On-The-Go B-Device of the On-The-Go Specification Rev1.3 supplement to the USB2.0.
- If the A-side of the USB cable is connected with a grounded ID, the OTG\_FS issues an ID line status change interrupt (CIDSCHG bit in OTG\_FS\_GINTSTS) for host software initialization, and automatically switches to the Host role. In this configuration the OTG\_FS complies with the standard FSM described by section 6.8.1: On-The-Go A-Device of the On-The-Go Specification Rev1.3 supplement to the USB2.0.

### 27.4.2 HNP dual role device

The HNP capable bit in the Global USB configuration register (HNPCAP bit in OTG\_FS\_GUSBCFG) enables the OTG\_FS Core to dynamically change its role from A-Host to A-peripheral and vice-versa, or from B-Peripheral to B-Host and vice-versa according to the host negotiation protocol (HNP). The current device status can be read by the combined values of the Connector ID Status bit in the Global OTG control and status register (CIDSTS bit in OTG\_FS\_GOTGCTL) and the current mode of operation bit in the global interrupt and status register (CMOD bit in OTG\_FS\_GINTSTS).

The HNP program model is described in detail in [Section 27.16: OTG\\_FS programming model](#).

### 27.4.3 SRP dual role device

The SRP capable bit in the global USB configuration register (SRPCAP bit in OTG\_FS\_GUSBCFG) enables the OTG\_FS Core to switch off the generation of  $V_{BUS}$  for the A-Device to save power. Note that the A-Device is always in charge of driving  $V_{BUS}$  regardless of the host or peripheral role of the OTG\_FS.

the SRP A/B-Device program model is described in detail in [Section 27.16: OTG\\_FS programming model](#).

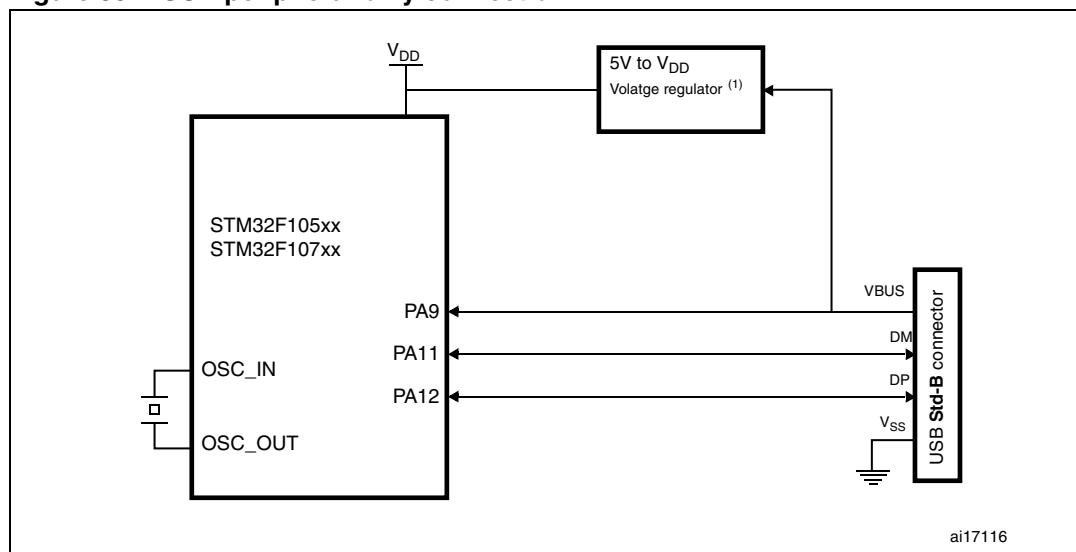
## 27.5 USB peripheral

This section gives the functional description of the OTG\_FS in the USB peripheral mode. The OTG\_FS works as an USB peripheral in the following circumstances:

- OTG B-Peripheral
  - OTG B-Device default state if B-side of USB cable is plugged in
- OTG A-Peripheral
  - OTG A-Device state after the HNP switches the OTG\_FS to its peripheral role
- B-Device
  - If the ID line is present, functional and connected to the B-side of the USB cable, and the HNP-capable bit in the Global USB Configuration register (HNPCAP bit in OTG\_FS\_GUSBCFG) is cleared (see On-The-Go Rev1.3 par. 6.8.3).
- Peripheral only (see [Figure 304: USB peripheral-only connection](#))
  - The force device mode bit in the Global USB configuration register (FDMOD in OTG\_FS\_GUSBCFG) is set to 1, forcing the OTG\_FS core to work as a USB peripheral-only (see On-The-Go Rev1.3 par. 6.8.3). In this case, the ID line is ignored even if present on the USB connector.

*Note:* To build a bus-powered device implementation in case of the B-Device or Peripheral-only configuration, an external regulator has to be added that generates the  $V_{DD}$  chip-supply from  $V_{BUS}$ .

**Figure 304. USB peripheral-only connection**



1. Use a regulator to build a bus-powered device.

### 27.5.1 SRP-capable peripheral

The SRP capable bit in the Global USB configuration register (SRPCAP bit in OTG\_FS\_GUSBCFG) enables the OTG\_FS to support the session request protocol (SRP). In this way, it allows the remote A-Device to save power by switching off  $V_{BUS}$  while the USB session is suspended.

The SRP peripheral mode program model is described in detail in the [B-device session request protocol](#) section.

## 27.5.2 Peripheral states

### Powered state

The  $V_{BUS}$  input detects the B-Session valid voltage by which the USB peripheral is allowed to enter the powered state (see USB2.0 par9.1). The OTG\_FS then automatically connects the DP pull-up resistor to signal full-speed device connection to the host and generates the session request interrupt (SRQINT bit in OTG\_FS\_GINTSTS) to notify the powered state.

The  $V_{BUS}$  input also ensures that valid  $V_{BUS}$  levels are supplied by the host during USB operations. If a drop in  $V_{BUS}$  below B-session valid happens to be detected (for instance because of a power disturbance or if the host port has been switched off), the OTG\_FS automatically disconnects and the session end detected (SEDET bit in OTG\_FS\_GOTGINT) interrupt is generated to notify that the OTG\_FS has exited the powered state.

In the powered state, the OTG\_FS expects to receive some reset signaling from the host. No other USB operation is possible. When a reset signaling is received the reset detected interrupt (USBRST in OTG\_FS\_GINTSTS) is generated. When the reset signaling is complete, the enumeration done interrupt (ENUMDNE bit in OTG\_FS\_GINTSTS) is generated and the OTG\_FS enters the Default state.

### Soft disconnect

The powered state can be exited by software with the soft disconnect feature. The DP pull-up resistor is removed by setting the soft disconnect bit in the device control register (SDIS bit in OTG\_FS\_DCTL), causing a device disconnect detection interrupt on the host side even though the USB cable was not really removed from the host port.

### Default state

In the Default state the OTG\_FS expects to receive a SET\_ADDRESS command from the host. No other USB operation is possible. When a valid SET\_ADDRESS command is decoded on the USB, the application writes the corresponding number into the device address field in the device configuration register (DAD bit in OTG\_FS\_DCFG). The OTG\_FS then enters the address state and is ready to answer host transactions at the configured USB address.

### Suspended state

The OTG\_FS peripheral constantly monitors the USB activity. After counting 3 ms of USB idleness, the early suspend interrupt (ESUSP bit in OTG\_FS\_GINTSTS) is issued, and confirmed 3 ms later, if appropriate, by the suspend interrupt (USBSUSP bit in OTG\_FS\_GINTSTS). The device suspend bit is then automatically set in the device status register (SUSPSTS bit in OTG\_FS\_DSTS) and the OTG\_FS enters the suspended state.

The suspended state may optionally be exited by the device itself. In this case the application sets the remote wakeup signaling bit in the device control register (WKUPINT bit in OTG\_FS\_DCTL) and clears it after 1 to 15 ms.

When a resume signaling is detected from the host, the resume interrupt (RWUSIG bit in OTG\_FS\_GINTSTS) is generated and the device suspend bit is automatically cleared.



### 27.5.3 Peripheral endpoints

The OTG\_FS core instantiates the following USB endpoints:

- Control endpoint 0
  - is bidirectional and handles control messages only
  - has a separate set of registers to handle in and out transactions
  - has proper control (OTG\_FS\_DIEPCTL0/OTG\_FS\_DOEPCTL0), transfer configuration (OTG\_FS\_DIEPTSIZ0/OTG\_FS\_DOEPSIZ0), and status-interrupt (OTG\_FS\_DIEPINTx/OTG\_FS\_DOEPINT0) registers. The available set of bits inside the control and transfer size registers slightly differs from that of other endpoints
- 3 IN endpoints
  - each of them can be configured to support the isochronous, bulk or interrupt transfer type
  - each of them has proper control (OTG\_FS\_DIEPCTLx), transfer configuration (OTG\_FS\_DIEPTSIZx), and status-interrupt (OTG\_FS\_DIEPINTx) registers
  - the Device IN endpoints common interrupt mask register (OTG\_FS\_DIEPMSK) is available to enable/disable a single kind of endpoint interrupt source on all of the IN endpoints (EP0 included)
  - support incomplete isochronous IN transfer interrupt (IISOIXFR bit in OTG\_FS\_GINTSTS), asserted when there is at least one isochronous IN endpoint on which the transfer is not completed in the current frame. This interrupt is asserted along with the end of periodic frame interrupt (OTG\_FS\_GINTSTS/EOPF).
- 3 OUT endpoints
  - each of them can be configured to support the isochronous, bulk or interrupt transfer type
  - each of them has a proper control (OTG\_FS\_DOEPCTLx), transfer configuration (OTG\_FS\_DOEPSIZx) and status-interrupt (OTG\_FS\_DOEPINTx) register
  - Device Out endpoints common interrupt mask register (OTG\_FS\_DOEPMSK) is available to enable/disable a single kind of endpoint interrupt source on all of the OUT endpoints (EP0 included)
  - support incomplete isochronous OUT transfer interrupt (INCOMPISOOOUT bit in OTG\_FS\_GINTSTS), asserted when there is at least one isochronous OUT endpoint on which the transfer is not completed in the current frame. This interrupt is asserted along with the end of periodic frame interrupt (OTG\_FS\_GINTSTS/EOPF).

### Endpoint control

- The following endpoint controls are available to the application through the device endpoint-x IN/OUT control register (DIEPCTLx/DOEPCTLx):
  - endpoint enable/disable
  - endpoint activation in current configuration
  - program the USB transfer type (isochronous, bulk, interrupt)
  - program the supported packet size
  - program the Tx-FIFO number associated with the IN endpoint
  - program the expected or transmitted data0/data1 PID (bulk/interrupt only)
  - program the even/odd frame during which the transaction is received or transmitted (isochronous only)
  - optionally program the NAK bit to always negative-acknowledge the host regardless of the FIFO status
  - optionally program the STALL bit to always stall host tokens to that endpoint
  - optionally program the SNOOP mode for OUT endpoint not to check the CRC field of received data

### Endpoint transfer

The device endpoint-x transfer size registers (DIEPTSIZx/DOEPTSIZx) allow the application to program the transfer size parameters and read the transfer status. Programming must be done before setting the endpoint enable bit in the endpoint control register. Once the endpoint is enabled, these fields are read-only as the OTG FS core updates them with the current transfer status.

- The following transfer parameters can be programmed:
  - transfer size in bytes
  - number of packets constituting the overall transfer size

### Endpoint status/interrupt

The device endpoint-x interrupt registers (DIEPINTx/DOPEPINTx) indicate the status of an endpoint with respect to USB- and AHB-related events. The application must read these registers when the OUT endpoint interrupt bit or the IN endpoint interrupt bit in the core interrupt register (OEPINT bit in OTG\_FS\_GINTSTS or IEPINT bit in OTG\_FS\_GINTSTS, respectively) is set. Before the application can read these registers, it must first read the device all endpoints interrupt (OTG\_FS\_DAIN) register to get the exact endpoint number

for the device endpoint-x interrupt register. The application must clear the appropriate bit in this register to clear the corresponding bits in the DAINTE and GINTSTS registers

- the peripheral core provides the following status checks and interrupt generation:
  - transfer completed interrupt, indicating that data transfer was completed on both the application (AHB) and USB sides
  - setup stage has been done (control-out only)
  - associated transmit FIFO is half or completely empty (in endpoints)
  - NAK acknowledge has been transmitted to the host (isochronous-in only)
  - IN token received when Tx-FIFO was empty (bulk-in/interrupt-in only)
  - out token received when endpoint was not yet enabled
  - babble error condition has been detected
  - endpoint disable by application is effective
  - endpoint NAK by application is effective (isochronous-in only)
  - more than 3 back-to-back setup packets were received (control-out only)
  - timeout condition detected (control-in only)
  - isochronous out packet has been dropped, without generating an interrupt

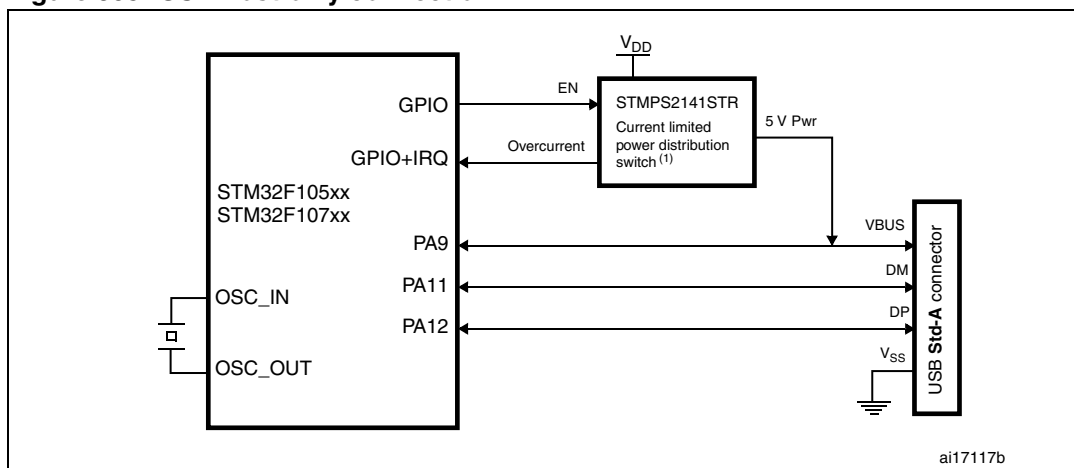
## 27.6 USB host

This section gives the functional description of the OTG\_FS in the USB host mode. The OTG\_FS works as a USB host in the following circumstances:

- OTG A-Host
  - OTG A-Device default state when the A-side of the USB cable is plugged in
- OTG B-Host
  - OTG B-Device after HNP switching to the host role
- A-Device
  - If the ID line is present, functional and connected to the A-side of the USB cable, and the HNP-capable bit is cleared in the Global USB Configuration register (HNPCAP bit in OTG\_FS\_GUSBCFG). Integrated pull-down resistors are automatically set on the DP/DM lines.
- Host only (see figure [Figure 305: USB host-only connection](#)).
  - The force host mode bit in the global USB configuration register (FHMOD bit in OTG\_FS\_GUSBCFG) forces the OTG\_FS core to work as a USB Host-only. In this case, the ID line is ignored even if present on the USB connector. Integrated pull-down resistors are automatically set on the DP/DM lines.

- Note:*
- 1 *On-chip 5 V  $V_{BUS}$  generation is not supported. For this reason, a charge pump or, if 5 V are available on the application board, a basic power switch must be added externally to drive the 5 V  $V_{BUS}$  line. The external charge pump can be driven by any GPIO output. This is required for the OTG A-Host, A-Device and Host-only configurations.*
  - 2 *The  $V_{BUS}$  input ensures that valid  $V_{BUS}$  levels are supplied by the charge pump during USB operations while the charge pump overcurrent output can be input to any GPIO pin configured to generate port interrupts. The overcurrent ISR must promptly disable the  $V_{BUS}$  generation.*

Figure 305. USB host-only connection



1. STMP2141STR needed only if the application has to support a  $V_{BUS}$  powered device. A basic power switch can be used if 5 V are available on the application board.

### 27.6.1 SRP-capable host

SRP support is available through the SRP capable bit in the global USB configuration register (SRPCAP bit in OTG\_FS\_GUSBCFG). With the SRP feature enabled, the Host can save power by switching off the  $V_{BUS}$  power while the USB session is suspended.

The SRP host mode program model is described in detail in the [A-device session request protocol](#) section.

### 27.6.2 USB host states

#### Host port power

On-chip 5 V  $V_{BUS}$  generation is not supported. For this reason, a charge pump or, if 5 V are available on the application board, a basic power switch, must be added externally to drive the 5 V  $V_{BUS}$  line. The external charge pump can be driven by any GPIO output. When the application decides to power on  $V_{BUS}$  using the chosen GPIO, it must also set the port power bit in the host port control and status register (PPWR bit in OTG\_FS\_HPRT).

#### $V_{BUS}$ valid

The  $V_{BUS}$  input ensures that valid  $V_{BUS}$  levels are supplied by the charge pump during USB operations.

Any unforeseen  $V_{BUS}$  voltage drop below the  $V_{BUS}$  valid threshold (4.25 V) leads to an OTG interrupt triggered by the session end detected bit (SEDET bit in OTG\_FS\_GOTGINT). The application is then required to remove the  $V_{BUS}$  power and clear the port power bit. The charge pump overcurrent flag can also be used to prevent electrical damage. Connect the overcurrent flag output from the charge pump to any GPIO input and configure it to generate a port interrupt on the active level. The overcurrent ISR must promptly disable the  $V_{BUS}$  generation and clear the port power bit.

#### Host detection of a peripheral connection

Even if USB peripherals or B-devices can be attached at any time, the OTG\_FS will not detect any bus connection until the end of the  $V_{BUS}$  sensing ( $V_{BUS}$  over 4.75 V).

When  $V_{BUS}$  is at a valid level and a remote B-device is attached, the OTG\_FS Core issues a host port interrupt triggered by the device connected bit in the host port control and status register (PCDET bit in OTG\_FS\_HPRT).

### Host detection of peripheral a disconnection

The peripheral disconnection event triggers the disconnect detected interrupt (DISCINT bit in OTG\_FS\_GINTSTS).

### Host enumeration

After detecting a peripheral connection the host must start the enumeration process by sending USB reset and configuration commands to the new peripheral.

Before starting to drive a USB reset, the application waits for the OTG interrupt triggered by the debounce done bit (DBCDNE bit in OTG\_FS\_GOTGINT), which indicates that the bus is stable again after the electrical debounce caused by the attachment of a pull-up resistor on DP (FS) or DM (LS).

The application drives a USB reset signaling (single-ended zero) over the USB by keeping the port reset bit set in the host port control and status register (PRST bit in OTG\_FS\_HPRT) for a minimum of 10 ms and a maximum of 20 ms. The application takes care of the timing count and then of clearing the port reset bit.

Once the USB reset sequence has completed, the host port interrupt is triggered by the port enable/disable change bit (PENCHNG bit in OTG\_FS\_HPRT). This informs the application that the speed of the enumerated peripheral can be read from the port speed field in the host port control and status register (PSPD bit in OTG\_FS\_HPRT) and that the host is starting to drive SOFs (FS) or Keep alives (LS). The Host is now ready to complete the peripheral enumeration by sending peripheral configuration commands.

### Host suspend

The application decides to suspend the USB activity by setting the port suspend bit in the host port control and status register (PSUSP bit in OTG\_FS\_HPRT). The OTG\_FS Core stops sending SOFs and enters the suspended state.

The suspended state can be optionally exited on the remote device's initiative (remote wakeup). In this case the remote wakeup interrupt (WKUPINT bit in OTG\_FS\_GINTSTS) is generated upon detection of a remote wakeup signaling, the port resume bit in the host port control and status register (PRES bit in OTG\_FS\_HPRT) self-sets, and resume signaling is automatically driven over the USB. The application must time the resume window and then clear the port resume bit to exit the suspended state and restart the SOF.

If the suspended state is exited on the host's initiative, the application must set the port resume bit to start resume signaling on the host port, time the resume window and finally clear the port resume bit.

## 27.6.3 Host channels

The OTG\_FS core instantiates 8 host channels. Each host channel supports an USB host transfer (USB pipe). The host is not able to support more than 8 transfer requests at the same time. If more than 8 transfer requests are pending from the application, the host controller driver (HCD) must re-allocate channels when they become available from previous duty, that is, after receiving the transfer completed and channel halted interrupts.

Each host channel can be configured to support in/out and any type of periodic/nonperiodic transaction. Each host channel makes use of proper control (HCCHAR $x$ ), transfer configuration (HCTSIZ $x$ ) and status/interrupt (HCINT $x$ ) registers with associated mask (HCINTMSK $x$ ) registers.

### Host channel control

- The following host channel controls are available to the application through the host channel- $x$  characteristics register (HCCHAR $x$ ):
  - channel enable/disable
  - program the FS/LS speed of target USB peripheral
  - program the address of target USB peripheral
  - program the endpoint number of target USB peripheral
  - program the transfer IN/OUT direction
  - program the USB transfer type (control, bulk, interrupt, isochronous)
  - program the maximum packet size (MPS)
  - program the periodic transfer to be executed during odd/even frames

### Host channel transfer

The host channel transfer size registers (HCTSIZ $x$ ) allow the application to program the transfer size parameters, and read the transfer status. Programming must be done before setting the channel enable bit in the host channel characteristics register. Once the endpoint is enabled the packet count field is read-only as the OTG FS core updates it according to the current transfer status.

- The following transfer parameters can be programmed:
  - transfer size in bytes
  - number of packets constituting the overall transfer size
  - initial data PID

### Host channel status/interrupt

The host channel- $x$  interrupt register (HCINT $x$ ) indicates the status of an endpoint with respect to USB- and AHB-related events. The application must read these registers when the host channels interrupt bit in the core interrupt register (HCINT bit in OTG\_FS\_GINTSTS) is set. Before the application can read these registers, it must first read the host all channels interrupt (HCAINT) register to get the exact channel number for the host channel- $x$  interrupt register. The application must clear the appropriate bit in this register to clear the

corresponding bits in the HAIN and GINTSTS registers. The mask bits for each interrupt source of each channel are also available in the OTG\_FS\_HCINTMSK-x register.

- The host core provides the following status checks and interrupt generation:
  - transfer completed interrupt, indicating that the data transfer is complete on both the application (AHB) and USB sides
  - channel has stopped due to transfer completed, USB transaction error or disable command from the application
  - associated transmit FIFO is half or completely empty (IN endpoints)
  - ACK response received
  - NAK response received
  - STALL response received
  - USB transaction error due to CRC failure, timeout, bit stuff error, false EOP
  - babble error
  - frame overrun
  - data toggle error

#### 27.6.4 Host scheduler

The host core features a built-in hardware scheduler able to autonomously re-order and drive over the USB the transaction requests posted by the application. At the beginning of each frame the host executes the periodic (isochronous and interrupt) traffic first, followed by the nonperiodic (control and bulk) traffic to accomplish the higher level of priority granted to the isochronous and interrupt transfer types by the USB specification.

The host pipes the USB transactions through request queues (one for periodic and one for nonperiodic). Each request queue can hold up to 8 entries. Each entry represents a pending transaction request from the application. Each entry in the request queue holds the IN or OUT channel number along with other information to perform a transaction on the USB. The order in which the requests are written into the queue determines the sequence of the transactions on the USB. The host processes the periodic request queue first, followed by the nonperiodic request queue, at the beginning of each frame. The host issues an incomplete periodic transfer interrupt (IPXFR bit in OTG\_FS\_GINTSTS) if an isochronous or interrupt transaction scheduled for the current frame is still pending at the end of the current frame.

The management of the periodic and nonperiodic request queues is completely in the hands of the OTG FS Core. A read-only register is available for the application to read the status of each request queue:

- Periodic transmit FIFO and queue status register (HPTXSTS) and non periodic transmit FIFO and queue status register (HNPTXSTS), containing the:
  - number of free entries currently available in the periodic (non periodic) request queue (8 max)
  - free space currently available in the periodic (nonperiodic) Tx-FIFO (out-transactions)
  - IN/OUT token, host channel number and other status information

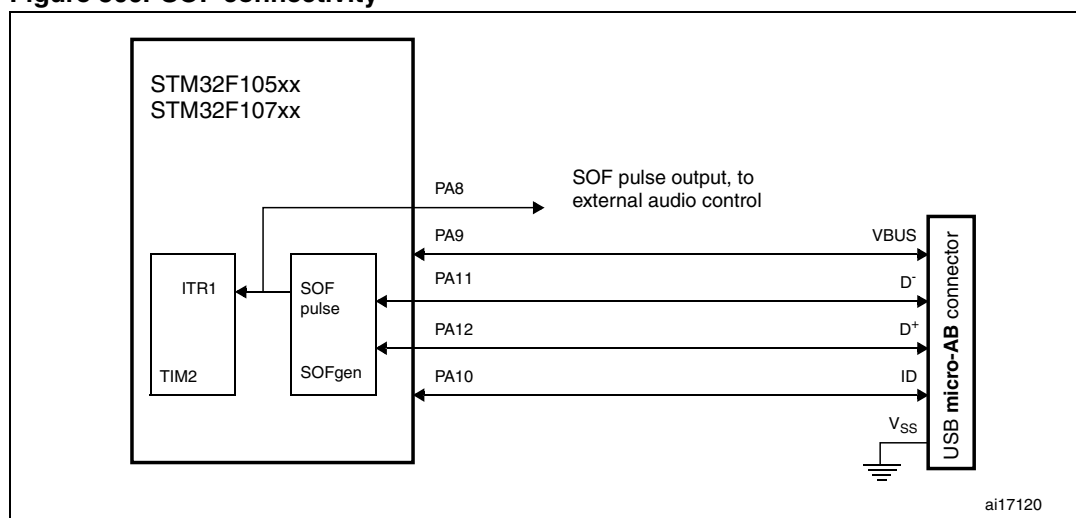
As request queues can hold a maximum of 8 entries each, the application can push to schedule host transactions in advance with respect to the moment they physically reach the USB for a maximum of 8 pending periodic transactions plus 8 pending nonperiodic transactions. For example, for a bulk in/out transfer, up to  $64$  (max bulk packet size)  $\times$   $8$  (max

entries) = 512 bytes of USB bulk traffic can be scheduled by the application and autonomously executed by the host at the maximum full-speed data rate without any application intervention.

- To post an out periodic (nonperiodic) transaction request to the host scheduler the application has to:
  - configure the transfer parameters on an available host channel
  - enable the configured channel
  - check that there is at least 1 entry available in the periodic (nonperiodic) request queue by reading the HPTXSTS bit in the OTG\_FS\_HNPTXSTS register
  - check that there is enough FIFO space in the periodic (nonperiodic) Tx FIFO (see [Section 27.11.2: Host Tx FIFOs](#)) by reading the HPTXSTS (HNPTXSTS) register. This step may not be necessary if the application submits the host transaction request upon reception of the periodic (nonperiodic) Tx FIFO half or completely empty interrupt
  - push the data payload to the associated FIFO address (push register). There is one push register for each enabled host channel. The data payload is automatically redirected to the periodic or nonperiodic Tx FIFO according to the host channel EPTYP bitfield in the OTG\_FS\_HCCHARx register. When the last 32-bit word data are written to the FIFO, an active entry is inserted at the bottom of the periodic (nonperiodic) request queue and the transaction request is scheduled for execution
- To post an IN periodic (nonperiodic) transaction request to the host scheduler the application has to:
  - configure the transfer parameters on an available host channel
  - enable the configured channel with the channel enable bit in the host channel characteristics register (CHENA bit in OTG\_FS\_HCCHARx). This inserts an active entry at the bottom of the periodic (nonperiodic) request queue and the transaction request is scheduled for execution

## 27.7 SOF trigger

Figure 306. SOF connectivity





The OTG FS Core provides:

- means to monitor, track and configure SOF framing in the host and peripheral
- an SOF pulse output connectivity feature

Such utilities are especially useful for adaptive audio clock generation techniques, where the audio peripheral needs to synchronize to the isochronous stream provided by the PC, or the Host needs to trim its framing rate according to the requirements of the audio peripheral.

### 27.7.1 Host SOFs

In Host mode the number of PHY clocks occurring between the generation of two consecutive SOF (FS) or Keep-alive (LS) tokens is programmable in the host frame interval register (HFIR), thus providing application control over the SOF framing period. An interrupt is generated at any start of frame (SOF bit in OTH\_FS\_GINTSTS). The current frame number and the time remaining until the next SOF are tracked in the host frame number register (HFNUM).

An SOF pulse signal, generated at any SOF starting token and with a width of 12 system clock cycles, can be made available externally on the SOF pin using the SOFOUTEN bit in the global control and configuration register. The SOF pulse is also internally connected to the input trigger of timer 2 (TIM2), so that the input capture feature, the output compare feature and the timer can be triggered by the SOF pulse. The TIM2 connection is enabled by bit 29 in the AFIO\_MAPR register.

### 27.7.2 Peripheral SOFs

In Device mode, the start of frame interrupt is generated each time an SOF token is received on the USB (SOF bit in OTH\_FS\_GINTSTS). The corresponding frame number can be read from the device status register (FNSOF bit in OTG\_FS\_DSTS). An SOF pulse signal with a width of 12 system clock cycles is also generated and can be made available externally on the SOF pin by using the SOF output enable bit in the global control and configuration register (SOFOUTEN bit in OTG\_FS\_GCCFG). The SOF pulse signal is also internally connected to the TIM2 input trigger, so that the input capture feature, the output compare feature and the timer can be triggered by the SOF pulse. The TIM2 connection is enabled by bit 29 in the AFIO\_MAPR register.

The end of periodic frame interrupt (GINTSTS/EOPF) is used to notify the application when 80%, 85%, 90% or 95% of the time frame interval elapsed depending on the periodic frame interval field in the device configuration register (PFIVL bit in OTG\_FS\_DCFG). This feature can be used to determine if all of the isochronous traffic for that frame is complete.

## 27.8 Power options

The power consumption of the OTG PHY is controlled by three bits in the general core configuration register:

- PHY power down (GCCFG/PWRDWN)
  - switch on/off the full-speed transceiver module of the PHY. Must be preliminarily set to allow any USB operation.
- A- $V_{BUS}$  sensing enable (GCCFG/VBUSASEN)
  - switch on/off the  $V_{BUS}$  comparators associated with A-Device operations. Must be set when in A-Device (USB Host) mode and during HNP.
- B- $V_{BUS}$  sensing enable (GCCFG/VBUSASEN)
  - switch on/off the  $V_{BUS}$  comparators associated with B-Device operations. Must be set when in B-Device (USB peripheral) mode and during HNP.

Power reduction techniques are available while in the USB suspended state, when the USB session is not yet valid or the device is disconnected.

- Stop PHY clock (STPPCLK bit in OTG\_FS\_PCGCCTL)
  - when setting the stop PHY clock bit in the clock gating control register, most of the 48 MHz clock domain internal to the OTG full-speed core is switched off by clock gating. The dynamic power consumption due to the USB clock switching activity is cut even if the 48 MHz clock input is kept running by the application
  - most of the transceiver is also disabled, and only the part in charge of detecting the asynchronous resume or remote wakeup event is kept alive.
- Gate HCLK (GATEHCLK bit in OTG\_FS\_PCGCCTL)
  - when setting the Gate HCLK bit in the clock gating control register, most of the system clock domain internal to the OTG\_FS Core is switched off by clock gating. Only the register read and write interface is kept alive. The dynamic power consumption due to the USB clock switching activity is cut even if the system clock is kept running by the application for other purposes.
- USB system stop
  - When the OTG\_FS is in the USB suspended state, the application may decide to drastically reduce the overall power consumption by a complete shut down of all the clock sources in the system. USB System Stop is activated by first setting the Stop PHY clock bit and then configuring the system deep sleep mode in the power control system module (PWR).
  - The OTG\_FS Core automatically reactivates both system and USB clocks by asynchronous detection of remote wakeup (as an Host) or resume (as a Device) signaling on the USB.

To save dynamic power, the USB data FIFO is clocked only when accessed by the OTG\_FS Core.

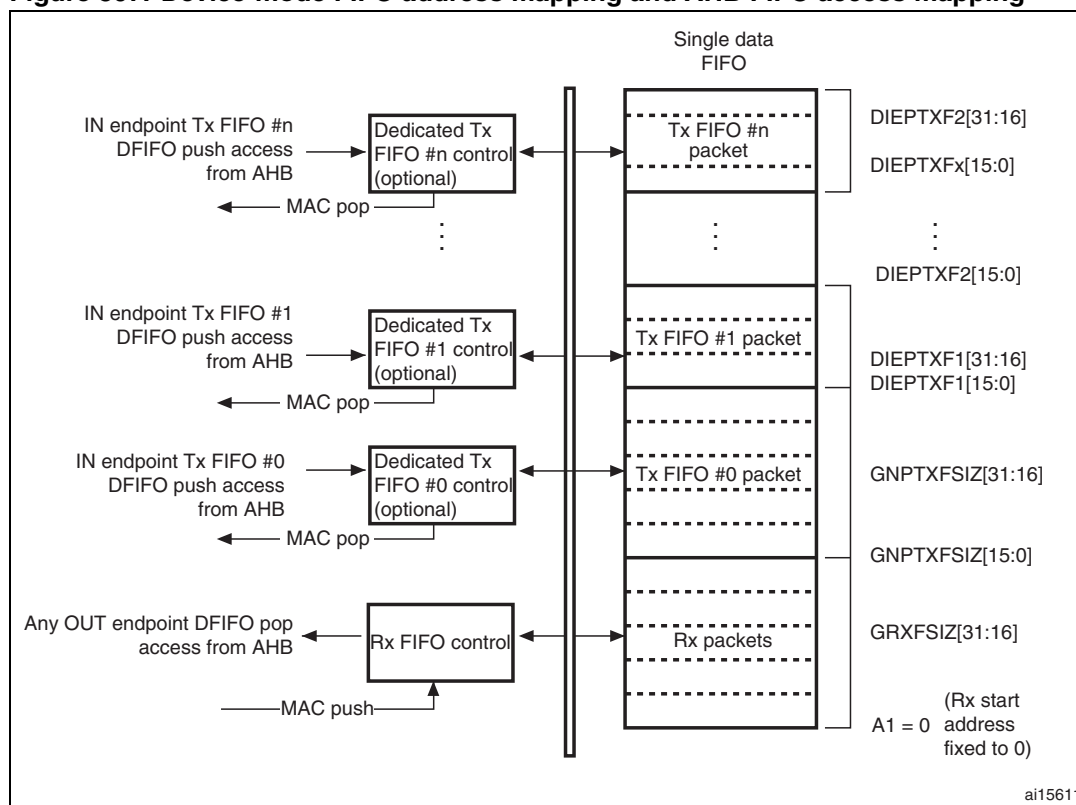
## 27.9 USB data FIFOs

The USB system features 1.25 Kbyte of dedicated RAM with a sophisticated FIFO control mechanism. The packet FIFO controller module in the OTG\_FS Core organizes RAM space into Tx-FIFOs into which the application pushes the data to be temporarily stored before the USB transmission, and into a single Rx FIFO where the data received from the USB are temporarily stored before retrieval (popped) by the application. The number of instructed

FIFOs and how these are architected inside the RAM depends on the device's role. In peripheral mode an additional Tx-FIFO is instructed for each active IN endpoint. Any FIFO size is software configured to better meet the application requirements.

## 27.10 Peripheral FIFO architecture

Figure 307. Device-mode FIFO address mapping and AHB FIFO access mapping



### 27.10.1 Peripheral Rx FIFO

The OTG peripheral uses a single receive FIFO that receives the data directed to all OUT endpoints. Received packets are stacked back-to-back until free space is available in the Rx-FIFO. The status of the received packet (which contains the OUT endpoint destination number, the byte count, the data PID and the validity of the received data) is also stored by the core on top of the data payload. When no more space is available, host transactions are NACKed and an interrupt is received on the addressed endpoint. The size of the receive FIFO is configured in the receive FIFO Size register (GRXFSIZ).

The single receive FIFO architecture makes it more efficient for the USB peripheral to fill in the receive RAM buffer

- all OUT endpoints share the same RAM buffer (shared FIFO)
- the OTG FS Core can fill in the receive FIFO up to the limit for any host sequence of OUT tokens

The application keeps receiving the Rx-FIFO non-empty interrupt (RXFLVL bit in OTG\_FS\_GINTSTS) as long as there is at least one packet available for download. It reads

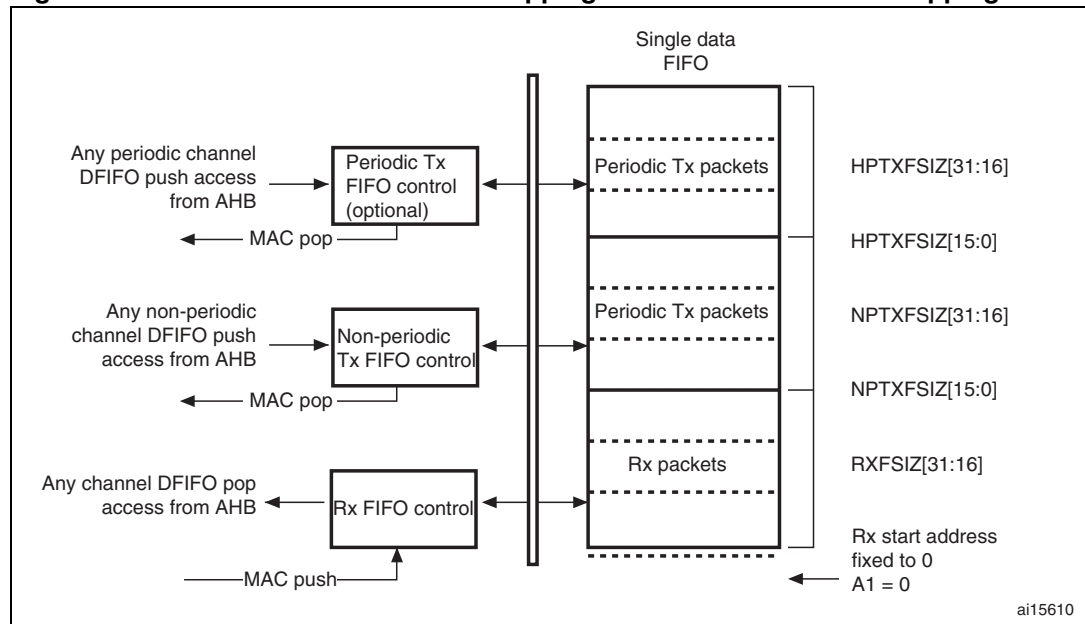
the packet information from the receive status read and pop register (GRXSTSP) and finally pops data off the receive FIFO by reading from the endpoint-related pop address.

### 27.10.2 Peripheral Tx FIFOs

The core has a dedicated FIFO for each IN endpoint. The application configures FIFO sizes by writing the non periodic transmit FIFO size register (OTG\_FS\_TX0FSIZ) for IN endpoint0 and the device IN endpoint transmit FIFOx registers (DIEPTXFx) for IN endpoint-x.

## 27.11 Host FIFO architecture

Figure 308. Host-mode FIFO address mapping and AHB FIFO access mapping



### 27.11.1 Host Rx FIFO

The host uses one receiver FIFO for all periodic and nonperiodic transactions. The FIFO is used as a receive buffer to hold the received data (payload of the received packet) from the USB until it is transferred to the system memory. Packets received from any remote IN endpoint are stacked back-to-back until free space is available. The status of each received packet with the host channel destination, byte count, data PID and validity of the received data are also stored into the FIFO. The size of the receive FIFO is configured in the receive FIFO size register (GRXFSIZ).

The single receive FIFO architecture makes it highly efficient for the USB host to fill in the receive data buffer:

- all IN configured host channels share the same RAM buffer (shared FIFO)
- the OTG FS Core can fill in the receive FIFO up to the limit for any sequence of IN tokens driven by the host software

The application receives the Rx FIFO not-empty interrupt as long as there is at least one packet available for download. It reads the packet information from the receive status read and pop register and finally pops the data off the receive FIFO.

## 27.11.2 Host Tx FIFOs

The host uses one transmit FIFO for all non-periodic (control and bulk) OUT transactions and one transmit FIFO for all periodic (isochronous and interrupt) OUT transactions. FIFOs are used as transmit buffers to hold the data (payload of the transmit packet) to be transmitted over the USB. The size of the periodic (nonperiodic) Tx FIFO is configured in the host periodic (nonperiodic) transmit FIFO size (HPTXFSIZ/HNPTXFSIZ) register.

The two Tx FIFO implementation derives from the higher priority granted to the periodic type of traffic over the USB frame. At the beginning of each frame, the built-in host scheduler processes the periodic request queue first, followed by the nonperiodic request queue.

The two transmit FIFO architecture provides the USB host with separate optimization for periodic and nonperiodic transmit data buffer management:

- all host channels configured to support periodic (nonperiodic) transactions in the OUT direction share the same RAM buffer (shared FIFOs)
- the OTG FS Core can fill in the periodic (nonperiodic) transmit FIFO up to the limit for any sequence of OUT tokens driven by the host software

The OTG\_FS Core issues the periodic Tx FIFO empty interrupt (PTXFE bit in OTG\_FS\_GINTSTS) as long as the periodic Tx-FIFO is half or completely empty, depending on the value of the periodic Tx-FIFO empty level bit in the AHB configuration register (PTXFELVL bit in OTG\_FS\_GAHBCFG). The application can push the transmission data in advance as long as free space is available in both the periodic Tx FIFO and the periodic request queue. The host periodic transmit FIFO and queue status register (HPTXSTS) can be read to know how much space is available in both.

OTG\_FS Core issues the non periodic Tx FIFO empty interrupt (NPTXFE bit in OTG\_FS\_GINTSTS) as long as the nonperiodic Tx FIFO is half or completely empty depending on the non periodic Tx FIFO empty level bit in the AHB configuration register (TXFELVL bit in OTG\_FS\_GAHBCFG). The application can push the transmission data as long as free space is available in both the nonperiodic Tx FIFO and nonperiodic request queue. The host nonperiodic transmit FIFO and queue status register (HNPTXSTS) can be read to know how much space is available in both.

## 27.12 FIFO RAM allocation

### 27.12.1 Device mode

**Receive FIFO RAM allocation:** the application should allocate RAM for SETUP Packets: 10 locations must be reserved in the receive FIFO to receive SETUP packets on control endpoint. The core does not use these locations, which are reserved for SETUP packets, to write any other data. One location is to be allocated for Global OUT NAK. Status information is written to the FIFO along with each received packet. Therefore, a minimum space of  $(\text{Largest Packet Size} / 4) + 1$  must be allocated to receive packets. If multiple isochronous endpoints are enabled, then at least two  $(\text{Largest Packet Size} / 4) + 1$  spaces must be allocated to receive back-to-back packets. Typically, two  $(\text{Largest Packet Size} / 4) + 1$  spaces are recommended so that when the previous packet is being transferred to the CPU, the USB can receive the subsequent packet.

Along with the last packet for each endpoint, transfer complete status information is also pushed to the FIFO. Typically, one location for each OUT endpoint is recommended.

**Transmit FIFO RAM allocation:** the minimum RAM space required for each IN Endpoint Transmit FIFO is the maximum packet size for that particular IN endpoint.

*Note: More space allocated in the transmit IN Endpoint FIFO results in better performance on the USB.*

## 27.12.2 Host mode

**Receive FIFO RAM allocation:** Status information is written to the FIFO along with each received packet. Therefore, a minimum space of  $(\text{Largest Packet Size} / 4) + 1$  must be allocated to receive packets. If multiple isochronous channels are enabled, then at least two  $(\text{Largest Packet Size} / 4) + 1$  spaces must be allocated to receive back-to-back packets. Typically, two  $(\text{Largest Packet Size} / 4) + 1$  spaces are recommended so that when the previous packet is being transferred to the CPU, the USB can receive the subsequent packet.

Along with the last packet in the host channel, transfer complete status information is also pushed to the FIFO. So one location must be allocated for this.

**Transmit FIFO RAM allocation:** the minimum amount of RAM required for the Host Non-periodic Transmit FIFO is the largest maximum packet size among all supported non-periodic OUT channels.

Typically, two Largest Packet Sizes worth of space is recommended, so that when the current packet is under transfer to the USB, the CPU can get the next packet.

The minimum amount of RAM required for Host periodic Transmit FIFO is the largest maximum packet size out of all the supported periodic OUT channels. If there is at least one Isochronous OUT endpoint, then the space must be at least two times the maximum packet size of that channel.

*Note: More space allocated in the Transmit Non-periodic FIFO results in better performance on the USB.*

## 27.13 USB system performance

Best USB and system performance is achieved owing to the large RAM buffers, the highly configurable FIFO sizes, the quick 32-bit FIFO access through AHB push/pop registers and, especially, the advanced FIFO control mechanism. Indeed, this mechanism allows the OTG\_FS to fill in the available RAM space at best regardless of the current USB sequence. With these features:

- The application gains good margins to calibrate its intervention in order to optimize the CPU bandwidth usage:
  - it can accumulate large amounts of transmission data in advance compared to when they are effectively sent over the USB
  - it benefits of a large time margin to download data from the single receive FIFO
- The USB Core is able to maintain its full operating rate, that is to provide maximum full-speed bandwidth with a great margin of autonomy versus application intervention:
  - it has a large reserve of transmission data at its disposal to autonomously manage the sending of data over the USB
  - it has a lot of empty space available in the receive buffer to autonomously fill it in with the data coming from the USB

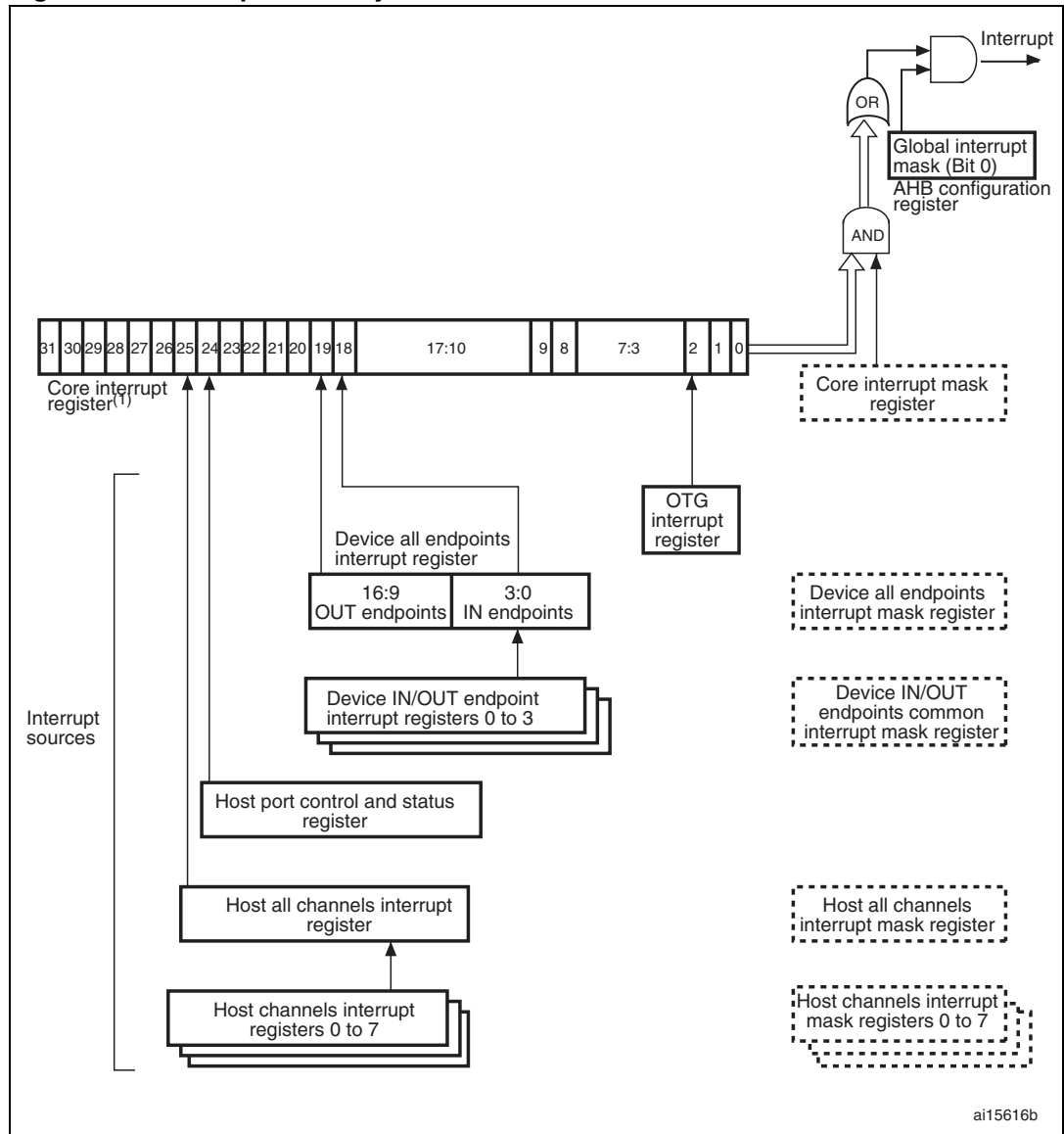
As the OTG\_FS Core is able to fill in the 1.25 Kbyte RAM buffer very efficiently, and as 1.25 Kbyte of transmit/receive data is more than enough to cover a full speed frame, the USB system is able to withstand the maximum full-speed data rate for up to one USB frame (1 ms) without any CPU intervention.

## 27.14 OTG\_FS interrupts

When the OTG\_FS controller is operating in one mode, either Device or Host, the application must not access registers from the other mode. If an illegal access occurs, a mode mismatch interrupt is generated and reflected in the Core interrupt register (MMIS bit in the OTG\_FS\_GINTSTS register). When the core switches from one mode to the other, the registers in the new mode of operation must be reprogrammed as they would be after a power-on reset.

*Figure 309* shows the interrupt hierarchy.

Figure 309. Interrupt hierarchy



1. The core interrupt register bits are shown in *OTG\_FS core interrupt register (OTG\_FS\_GINTSTS)* on page 815.



## 27.15 OTG\_FS control and status registers

By reading from and writing to the control and status registers (CSRs) through the AHB slave interface, the application controls the OTG\_FS controller. These registers are 32 bits wide, and the addresses are 32-bit block aligned. CSRs are classified as follows:

- Core global registers
- Host-mode registers
- Host global registers
- Host port CSRs
- Host channel-specific registers
- Device-mode registers
- Device global registers
- Device endpoint-specific registers
- Power and clock-gating registers
- Data FIFO (DFIFO) access registers

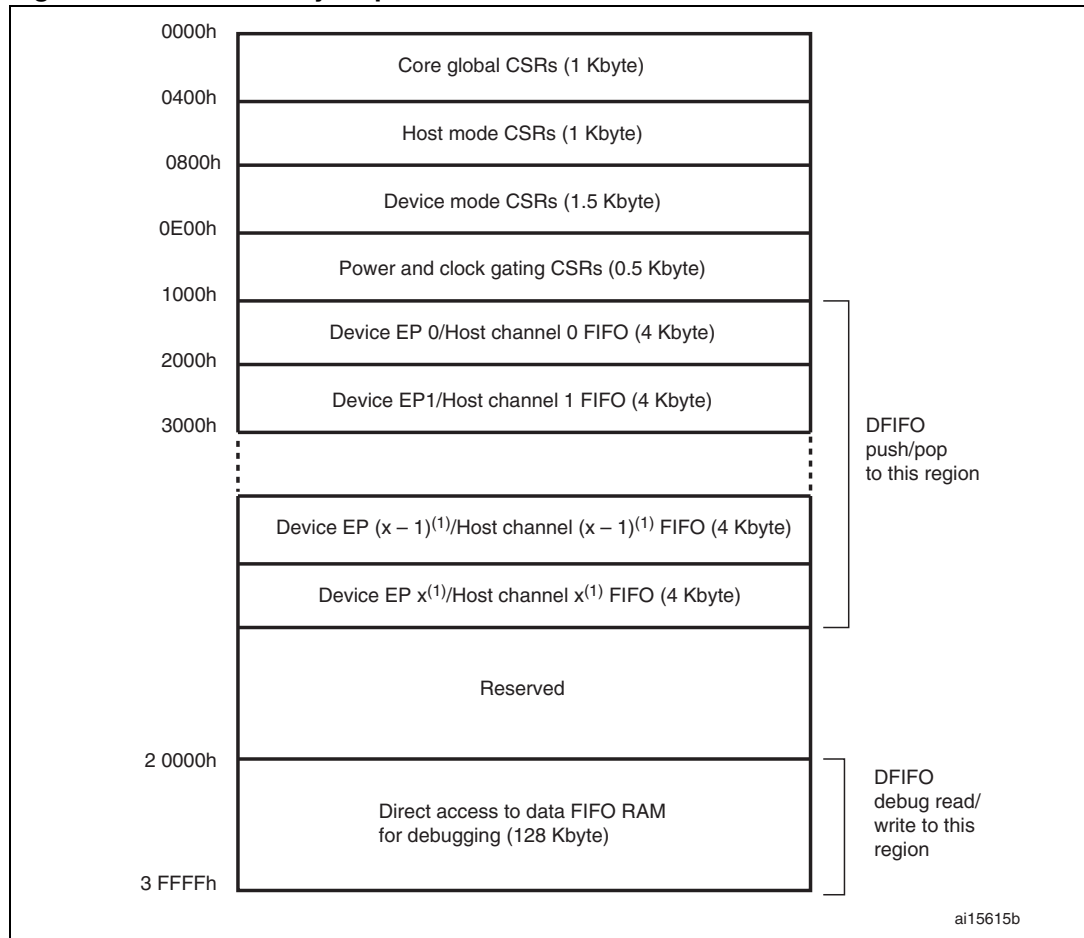
Only the Core global, Power and clock-gating, Data FIFO access, and Host port control and status registers can be accessed in both Host and Device modes. When the OTG\_FS controller is operating in one mode, either Device or Host, the application must not access registers from the other mode. If an illegal access occurs, a mode mismatch interrupt is generated and reflected in the Core interrupt register (MMIS bit in the OTG\_FS\_GINTSTS register). When the core switches from one mode to the other, the registers in the new mode of operation must be reprogrammed as they would be after a power-on reset.

The peripheral registers have to be accessed by words (32-bit).

### 27.15.1 CSR memory map

The Host and Device mode registers occupy different addresses. All registers are implemented in the AHB clock domain.

**Figure 310. CSR memory map**



1. x = 3 in Device mode and x = 7 in Host mode.

**Global CSR map**

These registers are available in both Host and Device modes.

**Table 196. Core global control and status registers (CSRs)**

Acronym	Address offset	Register name
OTG_FS_GOTGCTL	0x000	<i>OTG_FS control and status register (OTG_FS_GOTGCTL) on page 806</i>
OTG_FS_GOTGINT	0x004	<i>OTG_FS interrupt register (OTG_FS_GOTGINT) on page 808</i>
OTG_FS_GAHBCFG	0x008	<i>OTG_FS AHB configuration register (OTG_FS_GAHBCFG) on page 810</i>
OTG_FS_GUSBCFG	0x00C	<i>OTG_FS USB configuration register (OTG_FS_GUSBCFG) on page 811</i>
OTG_FS_GRSTCTL	0x010	<i>OTG_FS reset register (OTG_FS_GRSTCTL) on page 813</i>
OTG_FS_GINTSTS	0x014	<i>OTG_FS core interrupt register (OTG_FS_GINTSTS) on page 815</i>
OTG_FS_GINTMSK	0x018	<i>OTG_FS interrupt mask register (OTG_FS_GINTMSK) on page 819</i>

**Table 196. Core global control and status registers (CSRs) (continued)**

Acronym	Address offset	Register name
OTG_FS_GRXSTSR	0x01C	<i>OTG_FS Receive status debug read/OTG status read and pop registers (OTG_FS_GRXSTSR/OTG_FS_GRXSTSP) on page 822</i>
OTG_FS_GRXSTSP	0x020	
OTG_FS_GRXFSIZ	0x024	<i>OTG_FS Receive FIFO size register (OTG_FS_GRXFSIZ) on page 823</i>
OTG_FS_HNPTXFSIZ/ OTG_FS_DIEPTXF0 <sup>(1)</sup>	0x028	<i>OTG_FS Host non-periodic transmit FIFO size register (OTG_FS_HNPTXFSIZ)/Endpoint 0 Transmit FIFO size (OTG_FS_DIEPTXF0)</i>
OTG_FS_HNPTXSTS	0x02C	<i>OTG_FS non-periodic transmit FIFO/queue status register (OTG_FS_HNPTXSTS) on page 824</i>
OTG_FS_GCCFG	0x038	<i>OTG_FS general core configuration register (OTG_FS_GCCFG) on page 825</i>
OTG_FS_CID	0x03C	<i>OTG_FS core ID register (OTG_FS_CID) on page 826</i>
OTG_FS_HPTXFSIZ	0x100	<i>OTG_FS Host periodic transmit FIFO size register (OTG_FS_HPTXFSIZ) on page 826</i>
OTG_FS_DIEPTFXx	0x104 0x124 ... 0x138	<i>OTG_FS device IN endpoint transmit FIFO size register (OTG_FS_DIEPTFXx) (x = 1..3, where x is the FIFO_number) on page 827</i>

1. The general rule is to use OTG\_FS\_HNPTXFSIZ for Host mode and OTG\_FS\_DIEPTXF0 for Device mode.

### Host-mode CSR map

These registers must be programmed every time the core changes to Host mode.

**Table 197. Host-mode control and status registers (CSRs)**

Acronym	Offset address	Register name
OTG_FS_HCFG	0x400	<i>OTG_FS host configuration register (OTG_FS_HCFG) on page 827</i>
OTG_FS_HFIR	0x404	<i>OTG_FS Host frame interval register (OTG_FS_HFIR) on page 828</i>
OTG_FS_HFNUM	0x408	<i>OTG_FS host frame number/frame time remaining register (OTG_FS_HFNUM) on page 829</i>
OTG_FS_HPTXSTS	0x410	<i>OTG_FS Host periodic transmit FIFO/queue status register (OTG_FS_HPTXSTS) on page 829</i>
OTG_FS_HAINT	0x414	<i>OTG_FS Host all channels interrupt register (OTG_FS_HAINT) on page 830</i>
OTG_FS_HAINTMSK	0x418	<i>OTG_FS host all channels interrupt mask register (OTG_FS_HAINTMSK) on page 831</i>
OTG_FS_HPRT	0x440	<i>OTG_FS host port control and status register (OTG_FS_HPRT) on page 831</i>

**Table 197. Host-mode control and status registers (CSRs) (continued)**

Acronym	Offset address	Register name
OTG_FS_HCCHARx	0x500 0x520 ... 0x6E0h	<i>OTG_FS host channel-x characteristics register (OTG_FS_HCCHARx) (x = 0..7, where x = Channel_number) on page 834</i>
OTG_FS_HCINTx	508h	<i>OTG_FS host channel-x interrupt register (OTG_FS_HCINTx) (x = 0..7, where x = Channel_number) on page 835</i>
OTG_FS_HCINTMSKx	50Ch	<i>OTG_FS host channel-x interrupt mask register (OTG_FS_HCINTMSKx) (x = 0..7, where x = Channel_number) on page 836</i>
OTG_FS_HCTSIZx	510h	<i>OTG_FS host channel-x transfer size register (OTG_FS_HCTSIZx) (x = 0..7, where x = Channel_number) on page 837</i>

**Device-mode CSR map**

These registers must be programmed every time the core changes to Device mode.

**Table 198. Device-mode control and status registers**

Acronym	Offset address	Register name
OTG_FS_DCFG	0x800	<i>OTG_FS device configuration register (OTG_FS_DCFG) on page 838</i>
OTG_FS_DCTL	0x804	<i>OTG_FS device control register (OTG_FS_DCTL) on page 839</i>
OTG_FS_DSTS	0x808	<i>OTG_FS device status register (OTG_FS_DSTS) on page 840</i>
OTG_FS_DIEPMSK	0x810	<i>OTG_FS device IN endpoint common interrupt mask register (OTG_FS_DIEPMSK) on page 841</i>
OTG_FS_DOEPMSK	0x814	<i>OTG_FS device OUT endpoint common interrupt mask register (OTG_FS_DOEPMSK) on page 842</i>
OTG_FS_DAIN	0x818	<i>OTG_FS device all endpoints interrupt register (OTG_FS_DAIN) on page 843</i>
OTG_FS_DAINMSK	0x81C	<i>OTG_FS all endpoints interrupt mask register (OTG_FS_DAINMSK) on page 844</i>
OTG_FS_DVBUSDIS	0x828	<i>OTG_FS device VBUS discharge time register (OTG_FS_DVBUSDIS) on page 844</i>
OTG_FS_DVBUSPULSE	0x82C	<i>OTG_FS device VBUS pulsing time register (OTG_FS_DVBUSPULSE) on page 845</i>
OTG_FS_DIEPEMPMSK	0x834	<i>OTG_FS device IN endpoint FIFO empty interrupt mask register: (OTG_FS_DIEPEMPMSK) on page 845</i>
OTG_FS_DIEPCTL0	0x900	<i>OTG_FS device control IN endpoint 0 control register (OTG_FS_DIEPCTL0) on page 846</i>

Table 198. Device-mode control and status registers (continued)

Acronym	Offset address	Register name
OTG_FS_DIEPCTLx	0x920 0x940 ... 0xAE0	OTG device endpoint-x control register (OTG_FS_DIEPCTLx) (x = 1..3, where x = Endpoint_number) on page 847
OTG_FS_DIEPINTx	0x908	OTG_FS device endpoint-x interrupt register (OTG_FS_DIEPINTx) (x = 0..3, where x = Endpoint_number) on page 854
OTG_FS_DIEPTSIZ0	0x910	OTG_FS device IN endpoint 0 transfer size register (OTG_FS_DIEPTSIZ0) on page 856
OTG_FS_DTXFSTSx	0x918	OTG_FS device IN endpoint transmit FIFO status register (OTG_FS_DTXFSTSx) (x = 0..3, where x = Endpoint_number) on page 859
OTG_FS_DIEPTSIZx	0x930 0x950 ... 0xAF0	OTG_FS device OUT endpoint-x transfer size register (OTG_FS_DIEPTSIZx) (x = 1..3, where x = Endpoint_number) on page 859
OTG_FS_DOEPTCTL0	0xB00	OTG_FS device control OUT endpoint 0 control register (OTG_FS_DOEPTCTL0) on page 850
OTG_FS_DOEPTCTLx	0xB20 0xB40 ... 0xCC0 0xCE0 0xCFD	OTG device endpoint-x control register (OTG_FS_DIEPCTLx) (x = 1..3, where x = Endpoint_number) on page 847
OTG_FS_DOEPTINTx	0xB08	OTG_FS device endpoint-x interrupt register (OTG_FS_DIEPINTx) (x = 0..3, where x = Endpoint_number) on page 854
OTG_FS_DOEPTSIZx	0xB10	OTG_FS device OUT endpoint-x transfer size register (OTG_FS_DOEPTSIZx) (x = 1..3, where x = Endpoint_number) on page 859

### Data FIFO (DFIFO) access register map

These registers, available in both Host and Device modes, are used to read or write the FIFO space for a specific endpoint or a channel, in a given direction. If a host channel is of type IN, the FIFO can only be read on the channel. Similarly, if a host channel is of type OUT, the FIFO can only be written on the channel.

**Table 199. Data FIFO (DFIFO) access register map**

FIFO access register section	Address range	Access
Device IN Endpoint 0/Host OUT Channel 0: DFIFO Write Access Device OUT Endpoint 0/Host IN Channel 0: DFIFO Read Access	0x1000–0x1FFC	w r
Device IN Endpoint 1/Host OUT Channel 1: DFIFO Write Access Device OUT Endpoint 1/Host IN Channel 1: DFIFO Read Access	0x2000–0x2FFC	w r
...	...	...
Device IN Endpoint x <sup>(1)</sup> /Host OUT Channel x <sup>(1)</sup> : DFIFO Write Access Device OUT Endpoint x <sup>(1)</sup> /Host IN Channel x <sup>(1)</sup> : DFIFO Read Access	0xX000h–0xXFFCh	w r

1. Where x is 3 in device mode and 7 in host mode.

**Power and clock gating CSR map**

There is a single register for power and clock gating. It is available in both Host and Device modes.

**Table 200. Power and clock gating control and status registers**

Register name	Acronym	Offset address: 0xE00–0xFFF
Power and clock gating control register	PCGCR	0xE00-0xE04
Reserved		0xE05–0xFFF

**27.15.2 OTG\_FS global registers**

These registers are available in both Host and Device modes, and do not need to be reprogrammed when switching between these modes.

Bit values in the register descriptions are expressed in binary unless otherwise specified.

**OTG\_FS control and status register (OTG\_FS\_GOTGCTL)**

Address offset: 0x000

Reset value: 0x0000 0800

The OTG\_FS\_GOTGCTL register controls the behavior and reflects the status of the OTG function of the core.

31	30	29	28	27	26	25	24	23	22	21	20	19	18	17	16	15	14	13	12	11	10	9	8	7	6	5	4	3	2	1	0
Reserved												BSVLD	ASVLD	DBCT	CIDSTS	Reserved				DHNPN	HSHNPN	HNPRQ	HNGSCS	Reserved				SRQ	SRQSCS		
												r	r	r	r					rw	rw	rw	r					rw	r		

Bits 31:20 Reserved



- Bit 19 **BSVLD**: B-session valid  
Indicates the Device mode transceiver status.  
0: B-session is not valid.  
1: B-session is valid.  
In OTG mode, you can use this bit to determine if the device is connected or disconnected.  
*Note: Only accessible in Device mode.*
- Bit 18 **ASVLD**: A-session valid  
Indicates the Host mode transceiver status.  
0: A-session is not valid  
1: A-session is valid  
*Note: Only accessible in Host mode.*
- Bit 17 **DBCT**: Long/short debounce time  
Indicates the debounce time of a detected connection.  
0: Long debounce time, used for physical connections (100 ms + 2.5  $\mu$ s)  
1: Short debounce time, used for soft connections (2.5  $\mu$ s)  
*Note: Only accessible in Host mode.*
- Bit 16 **CIDSTS**: Connector ID status  
Indicates the connector ID status on a connect event.  
0: The OTG\_FS controller is in A-Device mode  
1: The OTG\_FS controller is in B-Device mode  
*Note: Accessible in both Device and Host modes.*
- Bits 15:12 Reserved
- Bit 11 **DHNPEN**: Device HNP enabled  
The application sets this bit when it successfully receives a SetFeature.SetHNPEnable command from the connected USB host.  
0: HNP is not enabled in the application  
1: HNP is enabled in the application  
*Note: Only accessible in Device mode.*
- Bit 10 **HSHPEN**: Host set HNP enable  
The application sets this bit when it has successfully enabled HNP (using the SetFeature.SetHNPEnable command) on the connected device.  
0: Host Set HNP is not enabled  
1: Host Set HNP is enabled  
*Note: Only accessible in Host mode.*
- Bit 9 **HNPRQ**: HNP request  
The application sets this bit to initiate an HNP request to the connected USB host. The application can clear this bit by writing a 0 when the host negotiation success status change bit in the OTG\_FS\_GOTGINT register (HNSSCHG bit in OTG\_FS\_GOTGINT) is set. The core clears this bit when the HNSSCHG bit is cleared.  
0: No HNP request  
1: HNP request  
*Note: Only accessible in Device mode.*

Bit 8 **HNGSCS**: Host negotiation success  
 The core sets this bit when host negotiation is successful. The core clears this bit when the HNP Request (HNPRQ) bit in this register is set.  
 0: Host negotiation failure  
 1: Host negotiation success  
*Note: Only accessible in Device mode.*

Bits 7:2 Reserved

Bit 1 **SRQ**: Session request  
 The application sets this bit to initiate a session request on the USB. The application can clear this bit by writing a 0 when the host negotiation success status change bit in the OTG\_FS\_GOTGINT register (HNSSCHG bit in OTG\_FS\_GOTGINT) is set. The core clears this bit when the HNSSCHG bit is cleared.  
 If you use the USB 1.1 full-speed serial transceiver interface to initiate the session request, the application must wait until  $V_{BUS}$  discharges to 0.2 V, after the B-Session Valid bit in this register (BSVLD bit in OTG\_FS\_GOTGCTL) is cleared. This discharge time varies between different PHYs and can be obtained from the PHY vendor.  
 0: No session request  
 1: Session request  
*Note: Only accessible in Device mode.*

Bit 0 **SRQSCS**: Session request success  
 The core sets this bit when a session request initiation is successful.  
 0: Session request failure  
 1: Session request success  
*Note: Only accessible in Device mode.*

### OTG\_FS interrupt register (OTG\_FS\_GOTGINT)

Address offset: 0x04

Reset value: 0x0000 0000

The application reads this register whenever there is an OTG interrupt and clears the bits in this register to clear the OTG interrupt.

31	30	29	28	27	26	25	24	23	22	21	20	19	18	17	16	15	14	13	12	11	10	9	8	7	6	5	4	3	2	1	0
Reserved												DBCNE	ADTOCHG	HNGDET	Reserved						HNSSCHG	SRSSCHG	Reserved				SEDET	Res.			
												rc_w1	rc_w1	rc_w1							rc_w1	rc_w1					rc_w1				

Bits 31:20 Reserved.

Bit 19 **DBCNE**: Debounce done  
 The core sets this bit when the debounce is completed after the device connect. The application can start driving USB reset after seeing this interrupt. This bit is only valid when the HNP Capable or SRP Capable bit is set in the OTG\_FS\_GUSBCFG register (HNPCAP bit or SRPCAP bit in OTG\_FS\_GUSBCFG, respectively).  
*Note: Only accessible in Host mode.*



- Bit 18 **ADTOCHG**: A-device timeout change  
The core sets this bit to indicate that the A-device has timed out while waiting for the B-device to connect.  
*Note: Accessible in both Device and Host modes.*
- Bit 17 **HNGDET**: Host negotiation detected  
The core sets this bit when it detects a host negotiation request on the USB.  
*Note: Accessible in both Device and Host modes.*
- Bits 16:10 Reserved.
- Bit 9 **HNSSCHG**: Host negotiation success status change  
The core sets this bit on the success or failure of a USB host negotiation request. The application must read the host negotiation success bit of the OTG\_FS\_GOTGCTL register (HNGSCS in OTG\_FS\_GOTGCTL) to check for success or failure.  
*Note: Accessible in both Device and Host modes.*
- Bits 7:3 Reserved.
- Bit 8 **SRSSCHG**: Session request success status change  
The core sets this bit on the success or failure of a session request. The application must read the session request success bit in the OTG\_FS\_GOTGCTL register (SRQSCS bit in OTG\_FS\_GOTGCTL) to check for success or failure.  
*Note: Accessible in both Device and Host modes.*
- Bit 2 **SEDET**: Session end detected  
The core sets this bit to indicate that the level of the voltage on  $V_{BUS}$  is no longer valid for a B-Peripheral session when  $V_{BUS} < 0.8$  V.
- Bits 1:0 Reserved.

**OTG\_FS AHB configuration register (OTG\_FS\_GAHBCFG)**

Address offset: 0x008

Reset value: 0x0000 0000

This register can be used to configure the core after power-on or a change in mode. This register mainly contains AHB system-related configuration parameters. Do not change this register after the initial programming. The application must program this register before starting any transactions on either the AHB or the USB.

31	30	29	28	27	26	25	24	23	22	21	20	19	18	17	16	15	14	13	12	11	10	9	8	7	6	5	4	3	2	1	0
Reserved																							PTXFELVL	TXFELVL	Reserved			GINTMSK			
																							rw	rw				rw			

Bits 31:20 Reserved.

Bit 8 **PTXFELVL**: Periodic Tx FIFO empty level

Indicates when the periodic Tx FIFO empty interrupt bit in the OTG\_FS\_GINTSTS register (PTXFE bit in OTG\_FS\_GINTSTS) is triggered.

- 0: PTXFE (in OTG\_FS\_GINTSTS) interrupt indicates that the Periodic Tx FIFO is half empty
- 1: PTXFE (in OTG\_FS\_GINTSTS) interrupt indicates that the Periodic Tx FIFO is completely empty

*Note: Only accessible in Host mode.*

Bit 7 **TXFELVL**: Tx FIFO empty level

In device mode, this bit indicates when IN endpoint Transmit FIFO empty interrupt (TXFE in OTG\_FS\_DIEPINTx.) is triggered.

- 0: the TXFE (in OTG\_FS\_DIEPINTx) interrupt indicates that the IN Endpoint Tx FIFO is half empty
- 1: the TXFE (in OTG\_FS\_DIEPINTx) interrupt indicates that the IN Endpoint Tx FIFO is completely empty

In host mode, this bit indicates when the nonperiodic Tx FIFO empty interrupt (NPTXFE bit in OTG\_FS\_GINTSTS) is triggered:

- 0: the NPTXFE (in OTG\_FS\_GINTSTS) interrupt indicates that the nonperiodic Tx FIFO is half empty
- 1: the NPTXFE (in OTG\_FS\_GINTSTS) interrupt indicates that the nonperiodic Tx FIFO is completely empty

Bits 6:1 Reserved.

Bit 0 **GINTMSK**: Global interrupt mask

The application uses this bit to mask or unmask the interrupt line assertion to itself. Irrespective of this bit's setting, the interrupt status registers are updated by the core.

- 0: Mask the interrupt assertion to the application.
- 1: Unmask the interrupt assertion to the application.

*Note: Accessible in both Device and Host modes.*

**OTG\_FS USB configuration register (OTG\_FS\_GUSBCFG)**

Address offset: 0x00C

Reset value: 0x0000 0A00

This register can be used to configure the core after power-on or a changing to Host mode or Device mode. It contains USB and USB-PHY related configuration parameters. The application must program this register before starting any transactions on either the AHB or the USB. Do not make changes to this register after the initial programming.

31	30	29	28	27	26	25	24	23	22	21	20	19	18	17	16	15	14	13	12	11	10	9	8	7	6	5	4	3	2	1	0
CTXPKT	FDMOD	FHMOD	Reserved											TRDT	HNPCAP	SRPCAP	PHYSEL	Reserved				TOCAL									
rw	rw	rw												rw	r/w	r/w	wo					rw									

Bits 31:20 Reserved.

Bit 31 **CTXPKT**: Corrupt Tx packet

This bit is for debug purposes only. Never set this bit to 1.

*Note: Accessible in both Device and Host modes.*

Bit 30 **FDMOD**: Force device mode

Writing a 1 to this bit forces the core to device mode irrespective of the OTG\_FS\_ID input pin.

- 0: Normal mode
- 1: Force device mode

After setting the force bit, the application must wait at least 25 ms before the change takes effect.

*Note: Accessible in both Device and Host modes.*

Bit 29 **FHMOD**: Force host mode

Writing a 1 to this bit forces the core to host mode irrespective of the OTG\_FS\_ID input pin.

- 0: Normal mode
- 1: Force host mode

After setting the force bit, the application must wait at least 25 ms before the change takes effect.

*Note: Accessible in both Device and Host modes.*

Bits 28:14 Reserved

Bits 13:10 **TRDT**: USB turnaround time

Sets the turnaround time in PHY clocks.

To calculate the value of TRDT, use the following formula:

$$TRDT = 4 \times AHB\ clock + 1\ PHY\ clock$$

Examples:

1. if AHB clock = 72 MHz (PHY Clock is 48), the TRDT is set to 9.
2. if AHB clock = 48 MHz (PHY Clock is 48), the TRDT is set to 5.

*Note: Only accessible in Device mode.*

Bit 9 **HNPCAP**: HNP-capable

The application uses this bit to control the OTG\_FS controller's HNP capabilities.

- 0: HNP capability is not enabled.
- 1: HNP capability is enabled.

*Note: Accessible in both Device and Host modes.*

Bit 8 **SRPCAP**: SRP-capable

The application uses this bit to control the OTG\_FS controller's SRP capabilities. If the core operates as a non-SRP-capable B-device, it cannot request the connected A-device (host) to activate  $V_{BUS}$  and start a session.

0: SRP capability is not enabled.

1: SRP capability is enabled.

*Note: Accessible in both Device and Host modes.*

Bit 7 **PHYSEL**: Full Speed serial transceiver select

This bit is always 1 with write-only access.

Bits [6:3] Reserved

Bits [2:0] **TOCAL**: FS timeout calibration

The number of PHY clocks that the application programs in this field is added to the full-speed interpacket timeout duration in the core to account for any additional delays introduced by the PHY. This can be required, because the delay introduced by the PHY in generating the line state condition can vary from one PHY to another.

The USB standard timeout value for full-speed operation is 16 to 18 (inclusive) bit times. The application must program this field based on the speed of enumeration. The number of bit times added per PHY clock is 0.25 bit times.

### OTG\_FS reset register (OTG\_FS\_GRSTCTL)

Address offset: 0x10

Reset value: 0x2000 0000

The application uses this register to reset various hardware features inside the core.

	31	30	29	28	27	26	25	24	23	22	21	20	19	18	17	16	15	14	13	12	11	10	9	8	7	6	5	4	3	2	1	0						
AHBIDL	Reserved																						TXFNUM			TXFFLSH	RXFFLSH	Reserved	FCRST	HSRST	CSRST							
r																							rw			rs	rs		rs	rs	rs							

**Bit 31 AHBIDL:** AHB master idle

Indicates that the AHB master state machine is in the Idle condition.

*Note: Accessible in both Device and Host modes.*

Bits 30:11 Reserved

**Bits 10:6 TXFNUM:** TxFIFO number

This is the FIFO number that must be flushed using the TxFIFO Flush bit. This field must not be changed until the core clears the TxFIFO Flush bit.

- 00000:
  - Non-periodic TxFIFO flush in Host mode
  - Tx FIFO 0 flush in Device mode
- 00001:
  - Periodic TxFIFO flush in Host mode
  - TXFIFO 1 flush in device mode
- 00010: TXFIFO 2 flush in device mode
- ...
- 00101: TXFIFO 15 flush in device mode
- 10000: Flush all the transmit FIFOs in device or host mode.

*Note: Accessible in both Device and Host modes.*

**Bit 5 TXFFLSH:** TxFIFO flush

This bit selectively flushes a single or all transmit FIFOs, but cannot do so if the core is in the midst of a transaction.

The application must write this bit only after checking that the core is neither writing to the TxFIFO nor reading from the TxFIFO. Verify using these registers:

- Read—NAK Effective Interrupt ensures the core is not reading from the FIFO
- Write—AHBIDL bit in OTG\_FS\_GRSTCTL ensures the core is not writing anything to the FIFO.

*Note: Accessible in both Device and Host modes.*

**Bit 4 RXFFLSH:** RxFIFO flush

The application can flush the entire RxFIFO using this bit, but must first ensure that the core is not in the middle of a transaction.

The application must only write to this bit after checking that the core is neither reading from the RxFIFO nor writing to the RxFIFO.

The application must wait until the bit is cleared before performing any other operations. This bit requires 8 clocks (slowest of PHY or AHB clock) to clear.

*Note: Accessible in both Device and Host modes.*

Bit 3 Reserved

Bit 2 **FCRST**: Host frame counter reset

The application writes this bit to reset the frame number counter inside the core. When the frame counter is reset, the subsequent SOF sent out by the core has a frame number of 0.

*Note: Only accessible in Host mode.*

Bit 1 **HSRST**: HCLK soft reset

The application uses this bit to flush the control logic in the AHB Clock domain. Only AHB Clock Domain pipelines are reset.

FIFOs are not flushed with this bit.

All state machines in the AHB clock domain are reset to the Idle state after terminating the transactions on the AHB, following the protocol.

CSR control bits used by the AHB clock domain state machines are cleared.

To clear this interrupt, status mask bits that control the interrupt status and are generated by the AHB clock domain state machine are cleared.

Because interrupt status bits are not cleared, the application can get the status of any core events that occurred after it set this bit.

This is a self-clearing bit that the core clears after all necessary logic is reset in the core. This can take several clocks, depending on the core's current state.

*Note: Accessible in both Device and Host modes.*

Bit 0 **CSRST**: Core soft reset

Resets the HCLK and PCLK domains as follows:

Clears the interrupts and all the CSR register bits except for the following bits:

- RSTPDMODL bit in OTG\_FS\_PCGCCTL
- GAYEHCLK bit in OTG\_FS\_PCGCCTL
- PWRLCMP bit in OTG\_FS\_PCGCCTL
- STPPCLK bit in OTG\_FS\_PCGCCTL
- FLSPCS bit in OTG\_FS\_HCFG
- DSPD bit in OTG\_FS\_DCFG

All module state machines (except for the AHB slave unit) are reset to the Idle state, and all the transmit FIFOs and the receive FIFO are flushed.

Any transactions on the AHB Master are terminated as soon as possible, after completing the last data phase of an AHB transfer. Any transactions on the USB are terminated immediately.

The application can write to this bit any time it wants to reset the core. This is a self-clearing bit and the core clears this bit after all the necessary logic is reset in the core, which can take several clocks, depending on the current state of the core. Once this bit has been cleared, the software must wait at least 3 PHY clocks before accessing the PHY domain (synchronization delay). The software must also check that bit 31 in this register is set to 1 (AHB Master is Idle) before starting any operation.

Typically, the software reset is used during software development and also when you dynamically change the PHY selection bits in the above listed USB configuration registers. When you change the PHY, the corresponding clock for the PHY is selected and used in the PHY domain. Once a new clock is selected, the PHY domain has to be reset for proper operation.

*Note: Accessible in both Device and Host modes.*

### OTG\_FS core interrupt register (OTG\_FS\_GINTSTS)

Address offset: 0x014

Reset value: 0x0400 0020

This register interrupts the application for system-level events in the current mode (Device mode or Host mode).

Some of the bits in this register are valid only in Host mode, while others are valid in Device mode only. This register also indicates the current mode. To clear the interrupt status bits of the rc\_w1 type, the application must write 1 into the bit.

The FIFO status interrupts are read-only; once software reads from or writes to the FIFO while servicing these interrupts, FIFO interrupt conditions are cleared automatically.

The application must clear the OTG\_FS\_GINTSTS register at initialization before unmasking the interrupt bit to avoid any interrupts generated prior to initialization.

31	30	29	28	27	26	25	24	23	22	21	20	19	18	17	16	15	14	13	12	11	10	9	8	7	6	5	4	3	2	1	0
WKUINT	SRQINT	DISCINT	CIDSCHG	Reserved	PTXFE	HCINT	HPRTINT	Reserved	IPXFR/INCOMPISOUT	ISOXFR	OEPIINT	IEPIINT	Reserved	EOFP	ISOODRP	ENUMDNE	USBFRST	USBSUSP	ESUSP	Reserved	GOUTNAKEFF	GINAKEFF	NPTXFE	RXFLVL	SOF	OTGINT	MMIS	CMOD			
rc_w1					r	r	r	Res.	rc_w1		r	r		rc_w1							r	r	r	r	rc_w1		r	rc_w1		r	

- Bit 31 WKUPIINT:** Resume/remote wakeup detected interrupt  
 In Device mode, this interrupt is asserted when a resume is detected on the USB. In Host mode, this interrupt is asserted when a remote wakeup is detected on the USB.  
*Note: Accessible in both Device and Host modes.*
- Bit 30 SRQINT:** Session request/new session detected interrupt  
 In Host mode, this interrupt is asserted when a session request is detected from the device. In Device mode, this interrupt is asserted when  $V_{BUS}$  is in the valid range for a B-peripheral device. Accessible in both Device and Host modes.
- Bit 29 DISCINT:** Disconnect detected interrupt  
 Asserted when a device disconnect is detected.  
*Note: Only accessible in Host mode.*
- Bit 28 CIDSCHG:** Connector ID status change  
 The core sets this bit when there is a change in connector ID status.  
*Note: Accessible in both Device and Host modes.*
- Bit 27** Reserved
- Bit 26 PTXFE:** Periodic TxFIFO empty  
 Asserted when the periodic transmit FIFO is either half or completely empty and there is space for at least one entry to be written in the periodic request queue. The half or completely empty status is determined by the periodic TxFIFO empty level bit in the OTG\_FS\_GAHBCFG register (PTXFELVL bit in OTG\_FS\_GAHBCFG).  
*Note: Only accessible in Host mode.*

**Bit 25 HCINT:** Host channels interrupt

The core sets this bit to indicate that an interrupt is pending on one of the channels of the core (in Host mode). The application must read the OTG\_FS\_HAINT register to determine the exact number of the channel on which the interrupt occurred, and then read the corresponding OTG\_FS\_HCINTx register to determine the exact cause of the interrupt. The application must clear the appropriate status bit in the OTG\_FS\_HCINTx register to clear this bit.

*Note: Only accessible in Host mode.*

**Bit 24 HPRTINT:** Host port interrupt

The core sets this bit to indicate a change in port status of one of the OTG\_FS controller ports in Host mode. The application must read the OTG\_FS\_HPRT register to determine the exact event that caused this interrupt. The application must clear the appropriate status bit in the OTG\_FS\_HPRT register to clear this bit.

*Note: Only accessible in Host mode.*

Bits 23:22 Reserved

**Bit 21 IPXFR:** Incomplete periodic transfer

In Host mode, the core sets this interrupt bit when there are incomplete periodic transactions still pending, which are scheduled for the current frame.

**INCOMPISOOUT:** Incomplete isochronous OUT transfer

In Device mode, the core sets this interrupt to indicate that there is at least one isochronous OUT endpoint on which the transfer is not completed in the current frame. This interrupt is asserted along with the End of periodic frame interrupt (EOPF) bit in this register.

**Bit 20 ISOIXFR:** Incomplete isochronous IN transfer

The core sets this interrupt to indicate that there is at least one isochronous IN endpoint on which the transfer is not completed in the current frame. This interrupt is asserted along with the End of periodic frame interrupt (EOPF) bit in this register.

*Note: Only accessible in Device mode.*

**Bit 19 OEPINT:** OUT endpoint interrupt

The core sets this bit to indicate that an interrupt is pending on one of the OUT endpoints of the core (in Device mode). The application must read the OTG\_FS\_DAIN register to determine the exact number of the OUT endpoint on which the interrupt occurred, and then read the corresponding OTG\_FS\_DOEPINTx register to determine the exact cause of the interrupt. The application must clear the appropriate status bit in the corresponding OTG\_FS\_DOEPINTx register to clear this bit.

*Note: Only accessible in Device mode.*

**Bit 18 IEPINT:** IN endpoint interrupt

The core sets this bit to indicate that an interrupt is pending on one of the IN endpoints of the core (in Device mode). The application must read the OTG\_FS\_DAIN register to determine the exact number of the IN endpoint on which the interrupt occurred, and then read the corresponding OTG\_FS\_DIEPINTx register to determine the exact cause of the interrupt. The application must clear the appropriate status bit in the corresponding OTG\_FS\_DIEPINTx register to clear this bit.

*Note: Only accessible in Device mode.*

Bits 17:16 Reserved

**Bit 15 EOPF:** End of periodic frame interrupt

Indicates that the period specified in the periodic frame interval field of the OTG\_FS\_DCFG register (PFIVL bit in OTG\_FS\_DCFG) has been reached in the current frame.

*Note: Only accessible in Device mode.*



- Bit 14 **ISOODRP**: Isochronous OUT packet dropped interrupt  
The core sets this bit when it fails to write an isochronous OUT packet into the RxFIFO because the RxFIFO does not have enough space to accommodate a maximum size packet for the isochronous OUT endpoint.  
*Note: Only accessible in Device mode.*
- Bit 13 **ENUMDNE**: Enumeration done  
The core sets this bit to indicate that speed enumeration is complete. The application must read the OTG\_FS\_DSTS register to obtain the enumerated speed.  
*Note: Only accessible in Device mode.*
- Bit 12 **USBRST**: USB reset  
The core sets this bit to indicate that a reset is detected on the USB.  
*Note: Only accessible in Device mode.*
- Bit 11 **USBSUSP**: USB suspend  
The core sets this bit to indicate that a suspend was detected on the USB. The core enters the Suspended state when there is no activity on the data lines for a period of 3 ms.  
*Note: Only accessible in Device mode.*
- Bit 10 **ESUSP**: Early suspend  
The core sets this bit to indicate that an Idle state has been detected on the USB for 3 ms.  
*Note: Only accessible in Device mode.*
- Bits 9:8 Reserved
- Bit 7 **GONAKEFF**: Global OUT NAK effective  
Indicates that the Set global OUT NAK bit in the OTG\_FS\_DCTL register (SGONAK bit in OTG\_FS\_DCTL), set by the application, has taken effect in the core. This bit can be cleared by writing the Clear global OUT NAK bit in the OTG\_FS\_DCTL register (CGONAK bit in OTG\_FS\_DCTL).  
*Note: Only accessible in Device mode.*
- Bit 6 **GINAKEFF**: Global IN non-periodic NAK effective  
Indicates that the Set global non-periodic IN NAK bit in the OTG\_FS\_DCTL register (SGINAK bit in OTG\_FS\_DCTL), set by the application, has taken effect in the core. That is, the core has sampled the Global IN NAK bit set by the application. This bit can be cleared by clearing the Clear global non-periodic IN NAK bit in the OTG\_FS\_DCTL register (CGINAK bit in OTG\_FS\_DCTL).  
This interrupt does not necessarily mean that a NAK handshake is sent out on the USB. The STALL bit takes precedence over the NAK bit.  
*Note: Only accessible in Device mode.*
- Bit 5 **NPTXFE**: Non-periodic TxFIFO empty  
This interrupt is asserted when the non-periodic TxFIFO is either half or completely empty, and there is space for at least one entry to be written to the non-periodic transmit request queue. The half or completely empty status is determined by the non-periodic TxFIFO empty level bit in the OTG\_FS\_GAHBCFG register (TXFELVL bit in OTG\_FS\_GAHBCFG).  
*Note: Accessible in Host mode only.*
- Bit 4 **RXFLVL**: RxFIFO non-empty  
Indicates that there is at least one packet pending to be read from the RxFIFO.  
*Note: Accessible in both Host and Device modes.*

**Bit 3 SOF:** Start of frame

In Host mode, the core sets this bit to indicate that an SOF (FS), or Keep-Alive (LS) is transmitted on the USB. The application must write a 1 to this bit to clear the interrupt.

In Device mode, the core sets this bit to indicate that an SOF token has been received on the USB. The application can read the Device Status register to get the current frame number. This interrupt is seen only when the core is operating in FS.

*Note: Accessible in both Host and Device modes.*

**Bit 2 OTGINT:** OTG interrupt

The core sets this bit to indicate an OTG protocol event. The application must read the OTG Interrupt Status (OTG\_FS\_GOTGINT) register to determine the exact event that caused this interrupt. The application must clear the appropriate status bit in the OTG\_FS\_GOTGINT register to clear this bit.

*Note: Accessible in both Host and Device modes.*

**Bit 1 MMIS:** Mode mismatch interrupt

The core sets this bit when the application is trying to access:

A Host mode register, when the core is operating in Device mode

A Device mode register, when the core is operating in Host mode

The register access is completed on the AHB with an OKAY response, but is ignored by the core internally and does not affect the operation of the core.

*Note: Accessible in both Host and Device modes.*

**Bit 0 CMOD:** Current mode of operation

Indicates the current mode.

0: Device mode

1: Host mode

*Note: Accessible in both Host and Device modes.*

**OTG\_FS interrupt mask register (OTG\_FS\_GINTMSK)**

Address offset: 0x018

Reset value: 0x0000 0000

This register works with the Core interrupt register to interrupt the application. When an interrupt bit is masked, the interrupt associated with that bit is not generated. However, the Core Interrupt (OTG\_FS\_GINTSTS) register bit corresponding to that interrupt is still set.

31	30	29	28	27	26	25	24	23	22	21	20	19	18	17	16	15	14	13	12	11	10	9	8	7	6	5	4	3	2	1	0
WUIM	SRQIM	DISCINT	CIDSCHGM	Reserved	PTXFEM	HCIM	PRTIM	Reserved	IPXFRM/IISOXFRM	IISOXFRM	OEPINT	IEPINT	EPMISM	Reserved	EOPFM	ISOODRPM	ENUMDNEM	USBRST	USBSUSPM	ESUSPM	Reserved	GONAKEFFM	GINAKEFFM	NPTXFEM	RXFLVLM	SOFM	OTGINT	MMISM	Reserved		
rw	rw	rw	rw		rw	rw	r		rw	rw	rw	rw	rw		rw	rw	rw	rw	rw	rw		rw	rw	rw	rw	rw	rw	rw	rw		

Bit 31 **WUIM**: Resume/remote wakeup detected interrupt mask

- 0: Masked interrupt
- 1: Unmasked interrupt

*Note: Accessible in both Host and Device modes.*

Bit 30 **SRQIM**: Session request/new session detected interrupt mask

- 0: Masked interrupt
- 1: Unmasked interrupt

*Note: Accessible in both Host and Device modes.*

Bit 29 **DISCINT**: Disconnect detected interrupt mask

- 0: Masked interrupt
- 1: Unmasked interrupt

*Note: Only accessible in Device mode.*

Bit 28 **CIDSCHGM**: Connector ID status change mask

- 0: Masked interrupt
- 1: Unmasked interrupt

*Note: Accessible in both Host and Device modes.*

Bit 27 Reserved

Bit 26 **PTXFEM**: Periodic Tx FIFO empty mask

- 0: Masked interrupt
- 1: Unmasked interrupt

*Note: Only accessible in Host mode.*

Bit 25 **HCIM**: Host channels interrupt mask

- 0: Masked interrupt
- 1: Unmasked interrupt

*Note: Only accessible in Host mode.*

Bit 24 **PRTIM**: Host port interrupt mask

- 0: Masked interrupt
- 1: Unmasked interrupt

*Note: Only accessible in Host mode.*

Bits 23:22 Reserved

Bit 21 **IPXFRM**: Incomplete periodic transfer mask

0: Masked interrupt

1: Unmasked interrupt

*Note: Only accessible in Host mode.*

**IISOXFRM**: Incomplete isochronous OUT transfer mask

0: Masked interrupt

1: Unmasked interrupt

*Note: Only accessible in Device mode.*

Bit 20 **IISOIXFRM**: Incomplete isochronous IN transfer mask

0: Masked interrupt

1: Unmasked interrupt

*Note: Only accessible in Device mode.*

Bit 19 **OEPINT**: OUT endpoints interrupt mask

0: Masked interrupt

1: Unmasked interrupt

*Note: Only accessible in Device mode.*

Bit 18 **IEPINT**: IN endpoints interrupt mask

0: Masked interrupt

1: Unmasked interrupt

*Note: Only accessible in Device mode.*

Bit 17 **EPMISM**: Endpoint mismatch interrupt mask

0: Masked interrupt

1: Unmasked interrupt

*Note: Only accessible in Device mode.*

Bit 16 Reserved

Bit 15 **EOPFM**: End of periodic frame interrupt mask

0: Masked interrupt

1: Unmasked interrupt

*Note: Only accessible in Device mode.*

Bit 14 **IISOODRPM**: Isochronous OUT packet dropped interrupt mask

0: Masked interrupt

1: Unmasked interrupt

*Note: Only accessible in Device mode.*

Bit 13 **ENUMDNEM**: Enumeration done mask

0: Masked interrupt

1: Unmasked interrupt

*Note: Only accessible in Device mode.*

Bit 12 **USBRST**: USB reset mask

0: Masked interrupt

1: Unmasked interrupt

*Note: Only accessible in Device mode.*

- Bit 11 **USBSUSPM**: USB suspend mask  
0: Masked interrupt  
1: Unmasked interrupt  
*Note: Only accessible in Device mode.*
- Bit 10 **ESUSPM**: Early suspend mask  
0: Masked interrupt  
1: Unmasked interrupt  
*Note: Only accessible in Device mode.*
- Bits 9:8 Reserved.
- Bit 7 **GONAKEFFM**: Global OUT NAK effective mask  
0: Masked interrupt  
1: Unmasked interrupt  
*Note: Only accessible in Device mode.*
- Bit 6 **GINAKEFFM**: Global non-periodic IN NAK effective mask  
0: Masked interrupt  
1: Unmasked interrupt  
*Note: Only accessible in Device mode.*
- Bit 5 **NPTXFEM**: Non-periodic TxFIFO empty mask  
0: Masked interrupt  
1: Unmasked interrupt  
*Note: Accessible in Host mode only.*
- Bit 4 **RXFLVLM**: Receive FIFO non-empty mask  
0: Masked interrupt  
1: Unmasked interrupt  
*Note: Accessible in both Device and Host modes.*
- Bit 3 **SOFM**: Start of frame mask  
0: Masked interrupt  
1: Unmasked interrupt  
*Note: Accessible in both Device and Host modes.*
- Bit 2 **OTGINT**: OTG interrupt mask  
0: Masked interrupt  
1: Unmasked interrupt  
*Note: Accessible in both Device and Host modes.*
- Bit 1 **MMISM**: Mode mismatch interrupt mask  
0: Masked interrupt  
1: Unmasked interrupt  
*Note: Accessible in both Device and Host modes.*
- Bit 0 Reserved

**OTG\_FS Receive status debug read/OTG status read and pop registers (OTG\_FS\_GRXSTSR/OTG\_FS\_GRXSTSP)**

Address offset for Read: 0x01C

Address offset for Pop: 0x020

Reset value: 0x0000 0000

A read to the Receive status debug read register returns the contents of the top of the Receive FIFO. A read to the Receive status read and pop register additionally pops the top data entry out of the RxFIFO.

The receive status contents must be interpreted differently in Host and Device modes. The core ignores the receive status pop/read when the receive FIFO is empty and returns a value of 0x0000 0000. The application must only pop the Receive Status FIFO when the Receive FIFO non-empty bit of the Core interrupt register (RXFLVL bit in OTG\_FS\_GINTSTS) is asserted.

**Host mode:**

31	30	29	28	27	26	25	24	23	22	21	20	19	18	17	16	15	14	13	12	11	10	9	8	7	6	5	4	3	2	1	0
Reserved											PKTSTS	DPID	BCNT						CHNUM												
											r	r	r						r												

Bits 31:21 Reserved

Bits 20:17 **PKTSTS**: Packet status

Indicates the status of the received packet

0010: IN data packet received

0011: IN transfer completed (triggers an interrupt)

0101: Data toggle error (triggers an interrupt)

0111: Channel halted (triggers an interrupt)

Others: Reserved

Bits 16:15 **DPID**: Data PID

Indicates the Data PID of the received packet

00: DATA0

10: DATA1

01: DATA2

11: MDATA

Bits 14:4 **BCNT**: Byte count

Indicates the byte count of the received IN data packet.

Bits 3:0 **CHNUM**: Channel number

Indicates the channel number to which the current received packet belongs.

**Device mode:**

31	30	29	28	27	26	25	24	23	22	21	20	19	18	17	16	15	14	13	12	11	10	9	8	7	6	5	4	3	2	1	0
Reserved							FRMNUM	PKTSTS	DPID	BCNT							EPNUM														
							r	r	r	r							r														

Bits 31:25 Reserved

Bits 24:21 **FRMNUM:** Frame number

This is the least significant 4 bits of the frame number in which the packet is received on the USB. This field is supported only when isochronous OUT endpoints are supported.

Bits 20:17 **PKTSTS:** Packet status

Indicates the status of the received packet

- 0001: Global OUT NAK (triggers an interrupt)
- 0010: OUT data packet received
- 0011: OUT transfer completed (triggers an interrupt)
- 0100: SETUP transaction completed (triggers an interrupt)
- 0110: SETUP data packet received
- Others: Reserved

Bits 16:15 **DPID:** Data PID

Indicates the Data PID of the received OUT data packet

- 00: DATA0
- 10: DATA1
- 01: DATA2
- 11: MDATA

Bits 14:4 **BCNT:** Byte count

Indicates the byte count of the received data packet.

Bits 3:0 **EPNUM:** Endpoint number

Indicates the endpoint number to which the current received packet belongs.

**OTG\_FS Receive FIFO size register (OTG\_FS\_GRXFSIZ)**

Address offset: 0x024

Reset value: 0x0000 0200

The application can program the RAM size that must be allocated to the RxFIFO.

31	30	29	28	27	26	25	24	23	22	21	20	19	18	17	16	15	14	13	12	11	10	9	8	7	6	5	4	3	2	1	0
Reserved																RXFD															
																r/rw															

Bits 31:16 Reserved

Bits 15:0 **RXFD:** RxFIFO depth

This value is in terms of 32-bit words.

- Minimum value is 16
- Maximum value is 256

The power-on reset value of this register is specified as the largest Rx data FIFO depth.

**OTG\_FS Host non-periodic transmit FIFO size register  
(OTG\_FS\_HNPTXFSIZ)/Endpoint 0 Transmit FIFO size (OTG\_FS\_DIEPTXF0)**

Address offset: 0x028

Reset value: 0x0000 0200

31	30	29	28	27	26	25	24	23	22	21	20	19	18	17	16	15	14	13	12	11	10	9	8	7	6	5	4	3	2	1	0
NPTXFD/TX0FD																NPTXFSA/TX0FSA															
r/rw																r/rw															

**Host mode**

Bits 31:16 **NPTXFD**: Non-periodic TxFIFO depth  
 This value is in terms of 32-bit words.  
 Minimum value is 16  
 Maximum value is 256

Bits 15:0 **NPTXFSA**: Non-periodic transmit RAM start address  
 This field contains the memory start address for non-periodic transmit FIFO RAM.

**Device mode**

Bits 31:16 **TX0FD**: Endpoint 0 TxFIFO depth  
 This value is in terms of 32-bit words.  
 Minimum value is 16  
 Maximum value is 256

Bits 15:0 **TX0FSA**: Endpoint 0 transmit RAM start address  
 This field contains the memory start address for the endpoint 0 transmit FIFO RAM.

**OTG\_FS non-periodic transmit FIFO/queue status register  
(OTG\_FS\_HNPTXSTS)**

Address offset: 0x02C

Reset value: 0x0008 0200

*Note: In Device mode, this register is not valid.*

This read-only register contains the free space information for the non-periodic TxFIFO and the non-periodic transmit request queue.

31	30	29	28	27	26	25	24	23	22	21	20	19	18	17	16	15	14	13	12	11	10	9	8	7	6	5	4	3	2	1	0
Reserved	NPTXQTOP								NPTQXSAV								NPTXFSAV														
	r								r								r														

Bit 31 Reserved



- Bits 30:24 **NPTXQTOP**: Top of the non-periodic transmit request queue  
 Entry in the non-periodic Tx request queue that is currently being processed by the MAC.  
 Bits [30:27]: Channel/endpoint number  
 Bits [26:25]:  
 - 00: IN/OUT token  
 - 01: Zero-length transmit packet (device IN/host OUT)  
 - 11: Channel halt command  
 Bit [24]: Terminate (last entry for selected channel/endpoint)
- Bits 23:16 **NPTQXSAV**: Non-periodic transmit request queue space available  
 Indicates the amount of free space available in the non-periodic transmit request queue. This queue holds both IN and OUT requests in Host mode. Device mode has only IN requests.  
 00: Non-periodic transmit request queue is full  
 01: dx1 location available  
 10: dx2 locations available  
*bxn*: dxn locations available ( $0 \leq n \leq dx8$ )  
 Others: Reserved
- Bits 15:0 **NPTXFSAV**: Non-periodic TxFIFO space available  
 Indicates the amount of free space available in the non-periodic TxFIFO.  
 Values are in terms of 32-bit words.  
 00: Non-periodic TxFIFO is full  
 01: dx1 word available  
 10: dx2 words available  
 0xn: dxn words available (where  $0 \leq n \leq dx256$ )  
 Others: Reserved

**OTG\_FS general core configuration register (OTG\_FS\_GCCFG)**

Address offset: 0x038

Reset value: 0x0000 0000

31	30	29	28	27	26	25	24	23	22	21	20	19	18	17	16	15	14	13	12	11	10	9	8	7	6	5	4	3	2	1	0
Reserved											SOFOUTEN	VBUSSEN	VBUSASEN	Reserved	PWRDWN	Reserved															
											rw	rw	rw		rw																

- Bits 31:21 Reserved
- Bit 20 **SOFOUTEN**: SOF output enable  
 0 = SOF pulse not available on PAD  
 1 = SOF pulse available on PAD
- Bit 19 **VBUSSEN**: Enable the V<sub>BUS</sub> sensing “B” device  
 0 = V<sub>BUS</sub> sensing “B” disabled  
 1 = V<sub>BUS</sub> sensing “B” enabled
- Bit 18 **VBUSASEN**: Enable the V<sub>BUS</sub> sensing “A” device  
 0 = V<sub>BUS</sub> sensing “A” disabled  
 1 = V<sub>BUS</sub> sensing “A” enabled

Bit 17 Reserved

Bit 16 **PWRDWN**: Power down  
 Used to activate the transceiver in transmission/reception  
 0 = Power down active  
 1 = Power down deactivated (“Transceiver active”)

Bits 15:0 Reserved.

**OTG\_FS core ID register (OTG\_FS\_CID)**

Address offset: 0x03C

Reset value:0x00001000

This is a read only register containing the Product ID.

31	30	29	28	27	26	25	24	23	22	21	20	19	18	17	16	15	14	13	12	11	10	9	8	7	6	5	4	3	2	1	0	
PRODUCT_ID																																
rw	rw	rw	rw	rw	rw	rw	rw	rw	rw	rw	rw	rw	rw	rw	rw	rw	rw	rw	rw	rw	rw	rw	rw	rw	rw	rw	rw	rw	rw	rw	rw	rw

Bits 31:0 **PRODUCT\_ID**: Product ID field  
 Application-programmable ID field.

**OTG\_FS Host periodic transmit FIFO size register (OTG\_FS\_HPTXFSIZ)**

Address offset: 0x100

Reset value: 0x0200 0600

31	30	29	28	27	26	25	24	23	22	21	20	19	18	17	16	15	14	13	12	11	10	9	8	7	6	5	4	3	2	1	0
PTXFSIZ																PTXSA															
r/r	r/r	r/r	r/r	r/r	r/r	r/r	r/r	r/r	r/r	r/r	r/r	r/r	r/r	r/r	r/r	r/r	r/r	r/r	r/r	r/r	r/r	r/r	r/r	r/r	r/r	r/r	r/r	r/r	r/r	r/r	r/r
w	w	w	w	w	w	w	w	w	w	w	w	w	w	w	w	w	w	w	w	w	w	w	w	w	w	w	w	w	w	w	w

Bits 31:16 **PTXFD**: Host periodic TxFIFO depth  
 This value is in terms of 32-bit words.  
 Minimum value is 16

Bits 15:0 **PTXSA**: Host periodic TxFIFO start address  
 The power-on reset value of this register is the sum of the largest Rx data FIFO depth and largest non-periodic Tx data FIFO depth.

**OTG\_FS device IN endpoint transmit FIFO size register (OTG\_FS\_DIEPTXF<sub>x</sub>)  
(x = 1..3, where x is the FIFO\_number)**

Address offset: 0x104 + (FIFO\_number – 1) × 0x04

Reset value: 0x02000400

31	30	29	28	27	26	25	24	23	22	21	20	19	18	17	16	15	14	13	12	11	10	9	8	7	6	5	4	3	2	1	0
INEPTXFD																INEPTXSA															
r/r	r/r	r/r	r/r	r/r	r/r	r/r	r/r	r/r	r/r	r/r	r/r	r/r	r/r	r/r	r/r	r/r	r/r	r/r	r/r	r/r	r/r	r/r	r/r	r/r	r/r	r/r	r/r	r/r	r/r	r/r	r/r
w	w	w	w	w	w	w	w	w	w	w	w	w	w	w	w	w	w	w	w	w	w	w	w	w	w	w	w	w	w	w	w

Bits 31:16 **INEPTXFD**: IN endpoint TxFIFO depth

This value is in terms of 32-bit words.

Minimum value is 16

The power-on reset value of this register is specified as the largest IN endpoint FIFO number depth.

Bits 15:0 **INEPTXSA**: IN endpoint FIFOx transmit RAM start address

This field contains the memory start address for IN endpoint transmit FIFOx.

**27.15.3 Host-mode registers**

Bit values in the register descriptions are expressed in binary unless otherwise specified.

Host-mode registers affect the operation of the core in the Host mode. Host mode registers must not be accessed in Device mode, as the results are undefined. Host Mode registers can be categorized as follows:

**OTG\_FS host configuration register (OTG\_FS\_HCFG)**

Address offset: 0x400

Reset value: 0x0000 0000

This register configures the core after power-on. Do not make changes to this register after initializing the host.

31	30	29	28	27	26	25	24	23	22	21	20	19	18	17	16	15	14	13	12	11	10	9	8	7	6	5	4	3	2	1	0
Reserved																										FSLSS	FSLSPCS				
																										r	rw	rw			

Bits 31:3 Reserved

Bit 2 **FSLSS**: FS- and LS-only support

The application uses this bit to control the core’s enumeration speed. Using this bit, the application can make the core enumerate as an FS host, even if the connected device supports HS traffic. Do not make changes to this field after initial programming.

1: FS/LS-only, even if the connected device can support HS (read-only)

Bits 1:0 **FSLSPCS**: FS/LS PHY clock select  
 When the core is in FS Host mode  
 01: PHY clock is running at 48 MHz  
 Others: Reserved

When the core is in LS Host mode  
 00: Reserved  
 01: Select 48 MHz PHY clock frequency  
 10: Select 6 MHz PHY clock frequency  
 11: Reserved

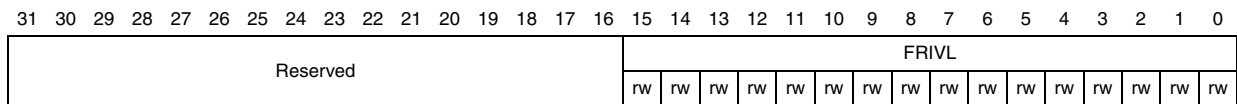
*Note: The FSLSPCS must be set on a connection event according to the speed of the connected device (after changing this bit, a software reset must be performed).*

**OTG\_FS Host frame interval register (OTG\_FS\_HFIR)**

Address offset: 0x404

Reset value: 0x0000 EA60

This register stores the frame interval information for the current speed to which the OTG\_FS controller has enumerated.



Bits 31:16 Reserved

Bits 15:0 **FRIVL**: Frame interval

The value that the application programs to this field specifies the interval between two consecutive SOFs (FS) or Keep-Alive tokens (LS). This field contains the number of PHY clocks that constitute the required frame interval. The application can write a value to this register only after the Port enable bit of the Host port control and status register (PENA bit in OTG\_FS\_HPRT) has been set. If no value is programmed, the core calculates the value based on the PHY clock specified in the FS/LS PHY Clock Select field of the Host configuration register (FSLSPCS in OTG\_FS\_HCFG). Do not change the value of this field after the initial configuration.

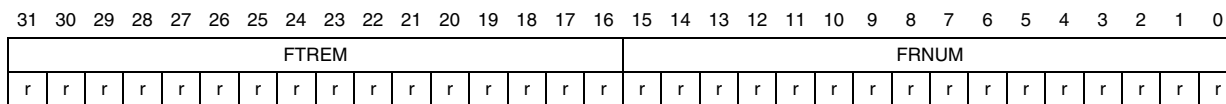
$$1 \text{ ms} \times (\text{PHY clock frequency})$$

**OTG\_FS host frame number/frame time remaining register (OTG\_FS\_HFNUM)**

Address offset: 0x408

Reset value: 0x0000 3FFF

This register indicates the current frame number. It also indicates the time remaining (in terms of the number of PHY clocks) in the current frame.



Bits 31:16 **FTREM**: Frame time remaining

Indicates the amount of time remaining in the current frame, in terms of PHY clocks. This field decrements on each PHY clock. When it reaches zero, this field is reloaded with the value in the Frame interval register and a new SOF is transmitted on the USB.

Bits 15:0 **FRNUM**: Frame number

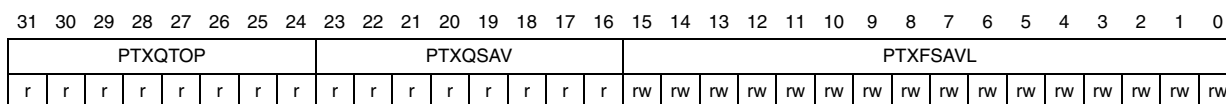
This field increments when a new SOF is transmitted on the USB, and is cleared to 0 when it reaches 0x3FFF.

**OTG\_FS\_Host periodic transmit FIFO/queue status register (OTG\_FS\_HPTXSTS)**

Address offset: 0x410

Reset value: 0x0008 0100

This read-only register contains the free space information for the periodic Tx FIFO and the periodic transmit request queue.



Bits 31:24 **PTXQTOP**: Top of the periodic transmit request queue

This indicates the entry in the periodic Tx request queue that is currently being processed by the MAC.

This register is used for debugging.

Bit [31]: Odd/Even frame

- 0: send in even frame
- 1: send in odd frame

Bits [30:27]: Channel/endpoint number

Bits [26:25]: Type

- 00: IN/OUT
- 01: Zero-length packet
- 11: Disable channel command

Bit [24]: Terminate (last entry for the selected channel/endpoint)

Bits 23:16 **PTXQSAV**: Periodic transmit request queue space available  
 Indicates the number of free locations available to be written in the periodic transmit request queue. This queue holds both IN and OUT requests.  
 00: Periodic transmit request queue is full  
 01: dx1 location available  
 10: dx2 locations available  
 bxn: dxn locations available ( $0 \leq dxn \leq 8$ )  
 Others: Reserved

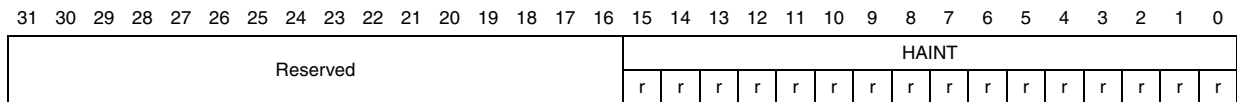
Bits 15:0 **PTXFSAVL**: Periodic transmit data FIFO space available  
 Indicates the number of free locations available to be written to in the periodic Tx FIFO.  
 Values are in terms of 32-bit words  
 0000: Periodic Tx FIFO is full  
 0001: dx1 word available  
 0010: dx2 words available  
 bxn: dxn words available (where  $0 \leq dxn \leq PTXFD$ )  
 Others: Reserved

**OTG\_FS Host all channels interrupt register (OTG\_FS\_HAINT)**

Address offset: 0x414

Reset value: 0x0000 000

When a significant event occurs on a channel, the Host all channels interrupt register interrupts the application using the Host channels interrupt bit of the Core interrupt register (HCINT bit in OTG\_FS\_GINTSTS). This is shown in *Figure 309*. There is one interrupt bit per channel, up to a maximum of 16 bits. Bits in this register are set and cleared when the application sets and clears bits in the corresponding Host channel-x interrupt register.



Bits 31:16 Reserved

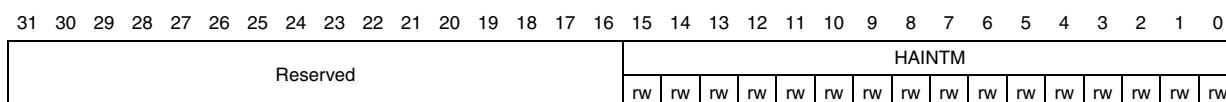
Bits 15:0 **HAINT**: Channel interrupts  
 One bit per channel: Bit 0 for Channel 0, bit 15 for Channel 15

### OTG\_FS host all channels interrupt mask register (OTG\_FS\_HAINTMSK)

Address offset: 0x418

Reset value: 0x0000 0000

The host all channel interrupt mask register works with the host all channel interrupt register to interrupt the application when an event occurs on a channel. There is one interrupt mask bit per channel, up to a maximum of 16 bits.



Bits 31:16 Reserved

Bits 15:0 **HAINTM**: Channel interrupt mask

0: Masked interrupt

1: Unmasked interrupt

One bit per channel: Bit 0 for channel 0, bit 15 for channel 15

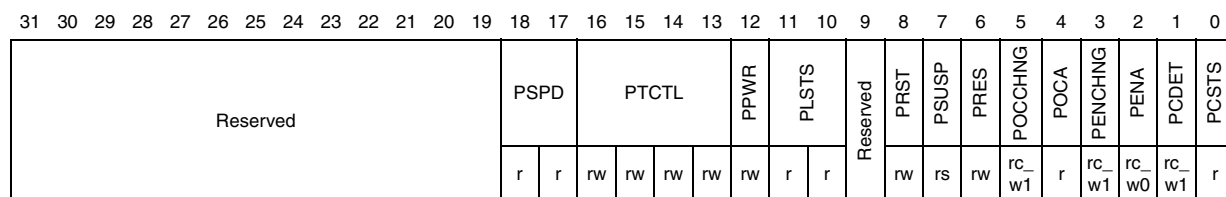
### OTG\_FS host port control and status register (OTG\_FS\_HPRT)

Address offset: 0x440

Reset value: 0x0000 0000

This register is available only in Host mode. Currently, the OTG Host supports only one port.

A single register holds USB port-related information such as USB reset, enable, suspend, resume, connect status, and test mode for each port. It is shown in [Figure 309](#). The rc\_w1 bits in this register can trigger an interrupt to the application through the Host port interrupt bit of the core interrupt register (HPRTINT bit in OTG\_FS\_GINTSTS). On a Port Interrupt, the application must read this register and clear the bit that caused the interrupt. For the rc\_w1 bits, the application must write a 1 to the bit to clear the interrupt.



Bits 31:19 Reserved

Bits 18:17 **PSPD**: Port speed

Indicates the speed of the device attached to this port.

01: Full speed

10: Low speed

11: Reserved

**Bits 16:13 PTCTL:** Port test control

The application writes a nonzero value to this field to put the port into a Test mode, and the corresponding pattern is signaled on the port.

- 0000: Test mode disabled
- 0001: Test\_J mode
- 0010: Test\_K mode
- 0011: Test\_SE0\_NAK mode
- 0100: Test\_Packet mode
- 0101: Test\_Force\_Enable
- Others: Reserved

**Bit 12 PPWR:** Port power

The application uses this field to control power to this port, and the core clears this bit on an overcurrent condition.

- 0: Power off
- 1: Power on

**Bits 11:10 PLSTS:** Port line status

Indicates the current logic level USB data lines

- Bit [10]: Logic level of OTG\_FS\_FS\_DP
- Bit [11]: Logic level of OTG\_FS\_FS\_DM

Bit 9 Reserved

**Bit 8 PRST:** Port reset

When the application sets this bit, a reset sequence is started on this port. The application must time the reset period and clear this bit after the reset sequence is complete.

- 0: Port not in reset
- 1: Port in reset

The application must leave this bit set for a minimum duration of at least 10 ms to start a reset on the port. The application can leave it set for another 10 ms in addition to the required minimum duration, before clearing the bit, even though there is no maximum limit set by the USB standard.

**Bit 7 PSUSP:** Port suspend

The application sets this bit to put this port in Suspend mode. The core only stops sending SOFs when this is set. To stop the PHY clock, the application must set the Port clock stop bit, which asserts the suspend input pin of the PHY.

The read value of this bit reflects the current suspend status of the port. This bit is cleared by the core after a remote wakeup signal is detected or the application sets the Port reset bit or Port resume bit in this register or the Resume/remote wakeup detected interrupt bit or Disconnect detected interrupt bit in the Core interrupt register (WKUINT or DISCINT in OTG\_FS\_GINTSTS, respectively).

- 0: Port not in Suspend mode
- 1: Port in Suspend mode



**Bit 6 PRES:** Port resume

The application sets this bit to drive resume signaling on the port. The core continues to drive the resume signal until the application clears this bit.

If the core detects a USB remote wakeup sequence, as indicated by the Port resume/remote wakeup detected interrupt bit of the Core interrupt register (WKUINT bit in OTG\_FS\_GINTSTS), the core starts driving resume signaling without application intervention and clears this bit when it detects a disconnect condition. The read value of this bit indicates whether the core is currently driving resume signaling.

- 0: No resume driven
- 1: Resume driven

**Bit 5 POCCHNG:** Port overcurrent change

The core sets this bit when the status of the Port overcurrent active bit (bit 4) in this register changes.

**Bit 4 POCA:** Port overcurrent active

Indicates the overcurrent condition of the port.

- 0: No overcurrent condition
- 1: Overcurrent condition

**Bit 3 PENCHNG:** Port enable/disable change

The core sets this bit when the status of the Port enable bit [2] in this register changes.

**Bit 2 PENA:** Port enable

A port is enabled only by the core after a reset sequence, and is disabled by an overcurrent condition, a disconnect condition, or by the application clearing this bit. The application cannot set this bit by a register write. It can only clear it to disable the port. This bit does not trigger any interrupt to the application.

- 0: Port disabled
- 1: Port enabled

**Bit 1 PCDET:** Port connect detected

The core sets this bit when a device connection is detected to trigger an interrupt to the application using the Host port interrupt bit in the Core interrupt register (HPRTINT bit in OTG\_FS\_GINTSTS). The application must write a 1 to this bit to clear the interrupt.

**Bit 0 PCSTS:** Port connect status

- 0: No device is attached to the port
- 1: A device is attached to the port

**OTG\_FS host channel-x characteristics register (OTG\_FS\_HCCHARx)  
(x = 0..7, where x = Channel\_number)**

Address offset: 0x500 + (Channel\_number × 0x20)

Reset value: 0x0000 0000

31	30	29	28	27	26	25	24	23	22	21	20	19	18	17	16	15	14	13	12	11	10	9	8	7	6	5	4	3	2	1	0	
CHENA	CHDIS	ODDFRM	DAD						MCNT		EPTYP		LSDEV	Reserved	EPDIR	EPNUM			MPSIZ													
rs	rs	rw	rw	rw	rw	rw	rw	rw	rw	rw	rw	rw	rw	rw		rw	rw	rw	rw	rw	rw	rw	rw	rw	rw	rw	rw	rw	rw	rw	rw	rw

**Bit 31 CHENA:** Channel enable

This field is set by the application and cleared by the OTG host.

- 0: Channel disabled
- 1: Channel enabled

**Bit 30 CHDIS:** Channel disable

The application sets this bit to stop transmitting/receiving data on a channel, even before the transfer for that channel is complete. The application must wait for the Channel disabled interrupt before treating the channel as disabled.

**Bit 29 ODDFRM:** Odd frame

This field is set (reset) by the application to indicate that the OTG host must perform a transfer in an odd frame. This field is applicable for only periodic (isochronous and interrupt) transactions.

- 0: Even frame
- 1: Odd frame

**Bits 28:22 DAD:** Device address

This field selects the specific device serving as the data source or sink.

**Bits 21:20 MCNT:** Multicount

This field indicates to the host the number of transactions that must be executed per frame for this periodic endpoint. For non-periodic transfers, this field is not used

- 00: Reserved. This field yields undefined results
- 01: 1 transaction
- 10: 2 transactions per frame to be issued for this endpoint
- 11: 3 transactions per frame to be issued for this endpoint

*Note: This field must be set to at least 01.*

**Bits 19:18 EPTYP:** Endpoint type

Indicates the transfer type selected.

- 00: Control
- 01: Isochronous
- 10: Bulk
- 11: Interrupt

**Bit 17 LSDEV:** Low-speed device

This field is set by the application to indicate that this channel is communicating to a low-speed device.

**Bit 16** Reserved

Bit 15 **EPDIR**: Endpoint direction  
 Indicates whether the transaction is IN or OUT.  
 0: OUT  
 1: IN

Bits 14:11 **EPNUM**: Endpoint number  
 Indicates the endpoint number on the device serving as the data source or sink.

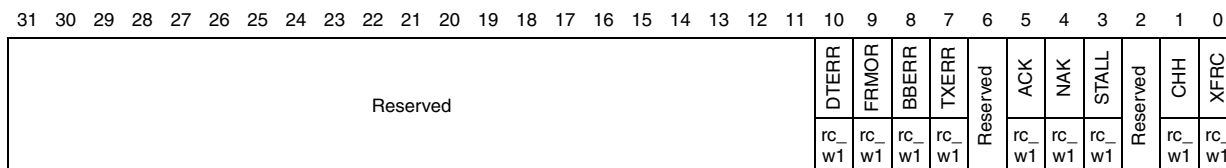
Bits 10:0 **MPSIZ**: Maximum packet size  
 Indicates the maximum packet size of the associated endpoint.

**OTG\_FS host channel-x interrupt register (OTG\_FS\_HCINTx) (x = 0..7, where x = Channel\_number)**

Address offset: 0x508 + (Channel\_number × 0x20)

Reset value: 0x0000 0000

This register indicates the status of a channel with respect to USB- and AHB-related events. It is shown in *Figure 309*. The application must read this register when the Host channels interrupt bit in the Core interrupt register (HCINT bit in OTG\_FS\_GINTSTS) is set. Before the application can read this register, it must first read the Host all channels interrupt (OTG\_FS\_HAINT) register to get the exact channel number for the Host channel-x interrupt register. The application must clear the appropriate bit in this register to clear the corresponding bits in the OTG\_FS\_HAINT and OTG\_FS\_GINTSTS registers.



Bits 31:11 Reserved

Bit 10 **DTERR**: Data toggle error

Bit 9 **FRMOR**: Frame overrun

Bit 8 **BBERR**: Babble error

Bit 7 **TXERR**: Transaction error

Indicates one of the following errors occurred on the USB.

CRC check failure

Timeout

Bit stuff error

False EOP

Bit 6 Reserved

Bit 5 **ACK**: ACK response received/transmitted interrupt

Bit 4 **NAK**: NAK response received interrupt

Bit 3 **STALL**: STALL response received interrupt

Bit 2 Reserved

Bit 1 **CHH**: Channel halted

Indicates the transfer completed abnormally either because of any USB transaction error or in response to disable request by the application.

Bit 0 **XFRC**: Transfer completed

Transfer completed normally without any errors.

**OTG\_FS host channel-x interrupt mask register (OTG\_FS\_HCINTMSKx)  
(x = 0..7, where x = Channel\_number)**

Address offset: 0x50C + (Channel\_number × 0x20)

Reset value: 0x0000 0000

This register reflects the mask for each channel status described in the previous section.

31	30	29	28	27	26	25	24	23	22	21	20	19	18	17	16	15	14	13	12	11	10	9	8	7	6	5	4	3	2	1	0
Reserved																					DTERRM	FRMORM	BBERRM	TXERRM	NYET	ACKM	NAKM	STALLM	Reserved	CHHM	XFRCM
																					rw	rw	rw	rw	rw	rw	rw	rw		rw	rw

Bits 31:11 Reserved

Bit 10 **DTERRM**: Data toggle error mask

0: Masked interrupt  
1: Unmasked interrupt

Bit 9 **FRMORM**: Frame overrun mask

0: Masked interrupt  
1: Unmasked interrupt

Bit 8 **BBERRM**: Babble error mask

0: Masked interrupt  
1: Unmasked interrupt

Bit 7 **TXERRM**: Transaction error mask

0: Masked interrupt  
1: Unmasked interrupt

Bit 6 **NYET**: response received interrupt mask

0: Masked interrupt  
1: Unmasked interrupt

Bit 5 **ACKM**: ACK response received/transmitted interrupt mask

0: Masked interrupt  
1: Unmasked interrupt

Bit 4 **NAKM**: NAK response received interrupt mask

0: Masked interrupt  
1: Unmasked interrupt

Bit 3 **STALLM**: STALL response received interrupt mask

0: Masked interrupt  
1: Unmasked interrupt

- Bit 2 Reserved
- Bit 1 **CHHM**: Channel halted mask
  - 0: Masked interrupt
  - 1: Unmasked interrupt
- Bit 0 **XFRM**: Transfer completed mask
  - 0: Masked interrupt
  - 1: Unmasked interrupt

**OTG\_FS host channel-x transfer size register (OTG\_FS\_HCTSIZx) (x = 0..7, where x = Channel\_number)**

Address offset: 0x510 + (Channel\_number × 0x20)

Reset value: 0x0000 0000

31	30	29	28	27	26	25	24	23	22	21	20	19	18	17	16	15	14	13	12	11	10	9	8	7	6	5	4	3	2	1	0
Reserved	DPID			PKTCNT									XFRSIZ																		
	rw	rw	rw	rw	rw	rw	rw	rw	rw	rw	rw	rw	rw	rw	rw	rw	rw	rw	rw	rw	rw	rw	rw	rw	rw	rw	rw	rw	rw	rw	rw

- Bit 31 Reserved
- Bits 30:29 **DPID**: Data PID
  - The application programs this field with the type of PID to use for the initial transaction. The host maintains this field for the rest of the transfer.
  - 00: DATA0
  - 01: DATA2
  - 10: DATA1
  - 11: MDATA (non-control)/SETUP (control)
- Bits 28:19 **PKTCNT**: Packet count
  - This field is programmed by the application with the expected number of packets to be transmitted (OUT) or received (IN).
  - The host decrements this count on every successful transmission or reception of an OUT/IN packet. Once this count reaches zero, the application is interrupted to indicate normal completion.
- Bits 18:0 **XFRSIZ**: Transfer size
  - For an OUT, this field is the number of data bytes the host sends during the transfer.
  - For an IN, this field is the buffer size that the application has reserved for the transfer. The application is expected to program this field as an integer multiple of the maximum packet size for IN transactions (periodic and non-periodic).

### 27.15.4 Device-mode registers

#### OTG\_FS device configuration register (OTG\_FS\_DCFG)

Address offset: 0x800

Reset value: 0x0220 0000

This register configures the core in Device mode after power-on or after certain control commands or enumeration. Do not make changes to this register after initial programming.

31	30	29	28	27	26	25	24	23	22	21	20	19	18	17	16	15	14	13	12	11	10	9	8	7	6	5	4	3	2	1	0																
Reserved																			PFIVL	DAD							Reserved	NZLSOHSK	DSPD																		
																			rw	rw	rw	rw	rw	rw	rw	rw	rw	rw	rw	rw	rw	rw	rw	rw	rw	rw	rw	rw	rw	rw	rw	rw	rw	rw	rw	rw	rw

Bits 31:13 Reserved

Bits 12:11 **PFIVL**: Periodic frame interval

Indicates the time within a frame at which the application must be notified using the end of periodic frame interrupt. This can be used to determine if all the isochronous traffic for that frame is complete.

- 00: 80% of the frame interval
- 01: 85% of the frame interval
- 10: 90% of the frame interval
- 11: 95% of the frame interval

Bits 10:4 **DAD**: Device address

The application must program this field after every SetAddress control command.

Bit 3 Reserved

Bit 2 **NZLSOHSK**: Non-zero-length status OUT handshake

The application can use this field to select the handshake the core sends on receiving a nonzero-length data packet during the OUT transaction of a control transfer's Status stage.

- 1: Send a STALL handshake on a nonzero-length status OUT transaction and do not send the received OUT packet to the application.
- 0: Send the received OUT packet to the application (zero-length or nonzero-length) and send a handshake based on the NAK and STALL bits for the endpoint in the Device endpoint control register.

Bits 1:0 **DSPD**: Device speed

Indicates the speed at which the application requires the core to enumerate, or the maximum speed the application can support. However, the actual bus speed is determined only after the chirp sequence is completed, and is based on the speed of the USB host to which the core is connected.

- 00: Reserved
- 01: Reserved
- 10: Reserved
- 11: Full speed (USB 1.1 transceiver clock is 48 MHz)

**OTG\_FS device control register (OTG\_FS\_DCTL)**

Address offset: 0x804

Reset value: 0x0000 0000

31	30	29	28	27	26	25	24	23	22	21	20	19	18	17	16	15	14	13	12	11	10	9	8	7	6	5	4	3	2	1	0	
Reserved																					POPGRDNE	CGONAK	SGONAK	CGINAK	SGINAK	TCTL			GONSTS	GINSTS	SDIS	RWUSIG
																					rw	w	w	w	w	rw	rw	rw	r	r	rw	rw

Bits 31:12 Reserved

Bit 11 **POPGRDNE**: Power-on programming done

The application uses this bit to indicate that register programming is completed after a wakeup from power down mode.

Bit 10 **CGONAK**: Clear global OUT NAK

A write to this field clears the Global OUT NAK.

Bit 9 **SGONAK**: Set global OUT NAK

A write to this field sets the Global OUT NAK.

The application uses this bit to send a NAK handshake on all OUT endpoints.

The application must set the this bit only after making sure that the Global OUT NAK effective bit in the Core interrupt register (GONAKEFF bit in OTG\_FS\_GINTSTS) is cleared.

Bit 8 **CGINAK**: Clear global IN NAK

A write to this field clears the Global IN NAK.

Bit 7 **SGINAK**: Set global IN NAK

A write to this field sets the Global non-periodic IN NAK. The application uses this bit to send a NAK handshake on all non-periodic IN endpoints.

The application must set this bit only after making sure that the Global IN NAK effective bit in the Core interrupt register (GINAKEFF bit in OTG\_FS\_GINTSTS) is cleared.

Bits 6:4 **TCTL**: Test control

000: Test mode disabled

001: Test\_J mode

010: Test\_K mode

011: Test\_SE0\_NAK mode

100: Test\_Packet mode

101: Test\_Force\_Enable

Others: Reserved

Bit 3 **GONSTS**: Global OUT NAK status

0: A handshake is sent based on the FIFO Status and the NAK and STALL bit settings.

1: No data is written to the Rx FIFO, irrespective of space availability. Sends a NAK handshake on all packets, except on SETUP transactions. All isochronous OUT packets are dropped.

Bit 2 **GINSTS**: Global IN NAK status

- 0: A handshake is sent out based on the data availability in the transmit FIFO.
- 1: A NAK handshake is sent out on all non-periodic IN endpoints, irrespective of the data availability in the transmit FIFO.

Bit 1 **SDIS**: Soft disconnect

The application uses this bit to signal the USB OTG core to perform a soft disconnect. As long as this bit is set, the host does not see that the device is connected, and the device does not receive signals on the USB. The core stays in the disconnected state until the application clears this bit.

- 0: Normal operation. When this bit is cleared after a soft disconnect, the core generates a device connect event to the USB host. When the device is reconnected, the USB host restarts device enumeration.
- 1: The core generates a device disconnect event to the USB host.

Bit 0 **RWUSIG**: Remote wakeup signaling

When the application sets this bit, the core initiates remote signaling to wake up the USB host. The application must set this bit to instruct the core to exit the Suspend state. As specified in the USB 2.0 specification, the application must clear this bit 1 ms to 15 ms after setting it.

*Table 201* contains the minimum duration (according to device state) for which the Soft disconnect (SDIS) bit must be set for the USB host to detect a device disconnect. To accommodate clock jitter, it is recommended that the application add some extra delay to the specified minimum duration.

**Table 201. Minimum duration for soft disconnect**

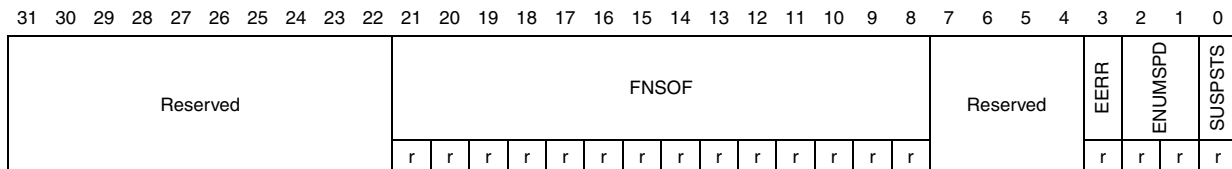
Operating speed	Device state	Minimum duration
Full speed	Suspended	1 ms + 2.5 μs
Full speed	Idle	2.5 μs
Full speed	Not Idle or Suspended (Performing transactions)	2.5 μs

**OTG\_FS device status register (OTG\_FS\_DSTS)**

Address offset: 0x808

Reset value: 0x0000 0010

This register indicates the status of the core with respect to USB-related events. It must be read on interrupts from the Device all interrupts (OTG\_FS\_DAINTE) register.



Bits 31:22 Reserved

Bits 21:8 **FNSOF**: Frame number of the received SOF

Bits 7:4 Reserved



- Bit 3 **EERR**: Erratic error  
 The core sets this bit to report any erratic errors.  
 Due to erratic errors, the OTG\_FS controller goes into Suspended state and an interrupt is generated to the application with Early suspend bit of the OTG\_FS\_GINTSTS register (ESUSP bit in OTG\_FS\_GINTSTS). If the early suspend is asserted due to an erratic error, the application can only perform a soft disconnect recover.
- Bits 2:1 **ENUMSPD**: Enumerated speed  
 Indicates the speed at which the OTG\_FS controller has come up after speed detection through a chirp sequence.  
 01: Reserved  
 10: Reserved  
 11: Full speed (PHY clock is running at 48 MHz)  
 Others: reserved
- Bit 0 **SUSPSTS**: Suspend status  
 In Device mode, this bit is set as long as a Suspend condition is detected on the USB. The core enters the Suspended state when there is no activity on the USB data lines for a period of 3 ms. The core comes out of the suspend:
  - When there is an activity on the USB data lines
  - When the application writes to the Remote wakeup signaling bit in the OTG\_FS\_DCTL register (RWUSIG bit in OTG\_FS\_DCTL).

**OTG\_FS device IN endpoint common interrupt mask register (OTG\_FS\_DIEPMSK)**

Address offset: 0x810  
 Reset value: 0x0000 0000

This register works with each of the OTG\_FS\_DIEPINTx registers for all endpoints to generate an interrupt per IN endpoint. The IN endpoint interrupt for a specific status in the OTG\_FS\_DIEPINTx register can be masked by writing to the corresponding bit in this register. Status bits are masked by default.

31	30	29	28	27	26	25	24	23	22	21	20	19	18	17	16	15	14	13	12	11	10	9	8	7	6	5	4	3	2	1	0
Reserved																								INPNEM	INPNMM	ITTXFEMSK	TOM	Reserved	EPDM	XFRM	
																								rw	rw	rw	rw	rw	rw	rw	

- Bits 31:7 Reserved
- Bit 6 **INPNEM**: IN endpoint NAK effective mask  
 0: Masked interrupt  
 1: Unmasked interrupt
- Bit 5 **INPNMM**: IN token received with EP mismatch mask  
 0: Masked interrupt  
 1: Unmasked interrupt
- Bit 4 **ITTXFEMSK**: IN token received when Tx FIFO empty mask  
 0: Masked interrupt  
 1: Unmasked interrupt



Bit 3 **TOM**: Timeout condition mask (Non-isochronous endpoints)  
 0: Masked interrupt  
 1: Unmasked interrupt

Bit 2 Reserved

Bit 1 **EPDM**: Endpoint disabled interrupt mask  
 0: Masked interrupt  
 1: Unmasked interrupt

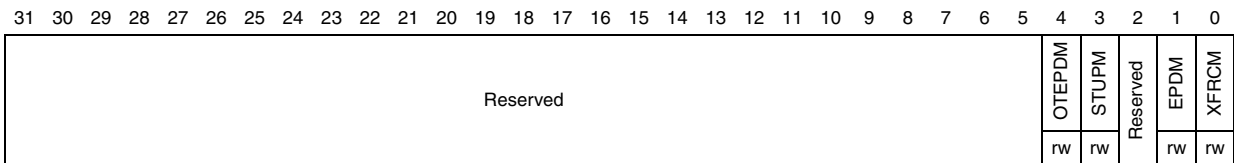
Bit 0 **XFRM**: Transfer completed interrupt mask  
 0: Masked interrupt  
 1: Unmasked interrupt

**OTG\_FS device OUT endpoint common interrupt mask register (OTG\_FS\_DOEPMSK)**

Address offset: 0x814

Reset value: 0x0000 0000

This register works with each of the OTG\_FS\_DOEPINTx registers for all endpoints to generate an interrupt per OUT endpoint. The OUT endpoint interrupt for a specific status in the OTG\_FS\_DOEPINTx register can be masked by writing into the corresponding bit in this register. Status bits are masked by default.



Bits 31:5 Reserved

Bit 4 **OTEPDM**: OUT token received when endpoint disabled mask  
 Applies to control OUT endpoints only.  
 0: Masked interrupt  
 1: Unmasked interrupt

Bit 3 **STUPM**: SETUP phase done mask  
 Applies to control endpoints only.  
 0: Masked interrupt  
 1: Unmasked interrupt

Bit 2 Reserved

Bit 1 **EPDM**: Endpoint disabled interrupt mask  
 0: Masked interrupt  
 1: Unmasked interrupt

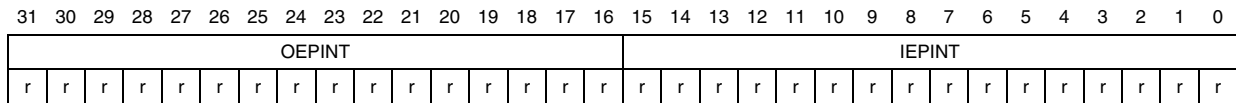
Bit 0 **XFRM**: Transfer completed interrupt mask  
 0: Masked interrupt  
 1: Unmasked interrupt

**OTG\_FS device all endpoints interrupt register (OTG\_FS\_DAIN)**

Address offset: 0x818

Reset value: 0x0000 0000

When a significant event occurs on an endpoint, a OTG\_FS\_DAIN register interrupts the application using the Device OUT endpoints interrupt bit or Device IN endpoints interrupt bit of the OTG\_FS\_GINTSTS register (OEPINT or IEPINT in OTG\_FS\_GINTSTS, respectively). There is one interrupt bit per endpoint, up to a maximum of 16 bits for OUT endpoints and 16 bits for IN endpoints. For a bidirectional endpoint, the corresponding IN and OUT interrupt bits are used. Bits in this register are set and cleared when the application sets and clears bits in the corresponding Device Endpoint-x interrupt register (OTG\_FS\_DIEPINTx/OTG\_FS\_DOEPINTx).



- Bits 31:16 **OEPINT**: OUT endpoint interrupt bits
  - One bit per OUT endpoint:
  - Bit 16 for OUT endpoint 0, bit 18 for OUT endpoint 3.
- Bits 15:0 **IEPINT**: IN endpoint interrupt bits
  - One bit per IN endpoint:
  - Bit 0 for IN endpoint 0, bit 3 for endpoint 3.

**OTG\_FS all endpoints interrupt mask register (OTG\_FS\_DAINMSK)**

Address offset: 0x81C

Reset value: 0x0000 0000

The OTG\_FS\_DAINMSK register works with the Device endpoint interrupt register to interrupt the application when an event occurs on a device endpoint. However, the OTG\_FS\_DAIN register bit corresponding to that interrupt is still set.

31	30	29	28	27	26	25	24	23	22	21	20	19	18	17	16	15	14	13	12	11	10	9	8	7	6	5	4	3	2	1	0
OEPM																IEPM															
rw	rw	rw	rw	rw	rw	rw	rw	rw	rw	rw	rw	rw	rw	rw	rw	rw	rw	rw	rw	rw	rw	rw	rw	rw	rw	rw	rw	rw	rw	rw	rw

Bits 31:16 **OEPM**: OUT EP interrupt mask bits  
 One per OUT endpoint:  
 Bit 16 for OUT EP 0, bit 18 for OUT EP 3  
 0: Masked interrupt  
 1: Unmasked interrupt

Bits 15:0 **IEPM**: IN EP interrupt mask bits  
 One bit per IN endpoint:  
 Bit 0 for IN EP 0, bit 3 for IN EP 3  
 0: Masked interrupt  
 1: Unmasked interrupt

**OTG\_FS device V<sub>BUS</sub> discharge time register (OTG\_FS\_DVBUSDIS)**

Address offset: 0x0828

Reset value: 0x0000 17D7

This register specifies the V<sub>BUS</sub> discharge time after V<sub>BUS</sub> pulsing during SRP.

31	30	29	28	27	26	25	24	23	22	21	20	19	18	17	16	15	14	13	12	11	10	9	8	7	6	5	4	3	2	1	0
Reserved																VBUSDT															
																rw	rw	rw	rw	rw	rw	rw	rw	rw	rw	rw	rw	rw	rw	rw	rw

Bits 31:16 Reserved

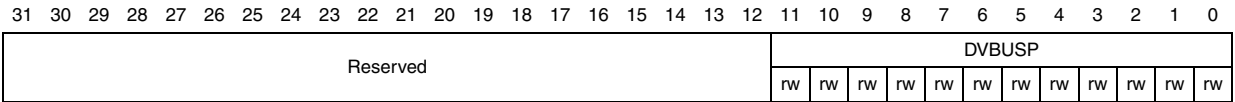
Bits 15:0 **VBUSDT**: Device V<sub>BUS</sub> discharge time  
 Specifies the V<sub>BUS</sub> discharge time after V<sub>BUS</sub> pulsing during SRP. This value equals:  
 V<sub>BUS</sub> discharge time in PHY clocks / 1 024  
 Depending on your V<sub>BUS</sub> load, this value may need adjusting.

**OTG\_FS device V<sub>BUS</sub> pulsing time register (OTG\_FS\_DVBUSPULSE)**

Address offset: 0x082C

Reset value: 0x0000 05B8

This register specifies the V<sub>BUS</sub> pulsing time during SRP.



Bits 31:12 Reserved

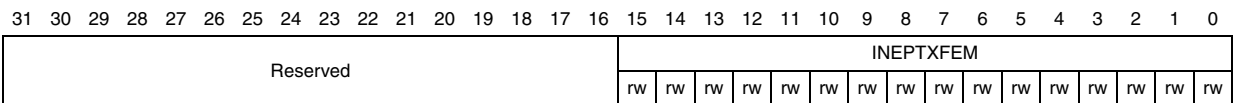
Bits 11:0 **DVBUSP**: Device V<sub>BUS</sub> pulsing time  
 Specifies the V<sub>BUS</sub> pulsing time during SRP. This value equals:  
 V<sub>BUS</sub> pulsing time in PHY clocks / 1 024

**OTG\_FS device IN endpoint FIFO empty interrupt mask register:  
(OTG\_FS\_DIEPMPMSK)**

Address offset: 0x834

Reset value: 0x0000 0000

This register is used to control the IN endpoint FIFO empty interrupt generation (TXFE\_OTG\_FS\_DIEPINTx).



Bits 31:16 Reserved

Bits 15:0 **INEPTXFEM**: IN EP Tx FIFO empty interrupt mask bits  
 These bits act as mask bits for OTG\_FS\_DIEPINTx.  
 TXFE interrupt one bit per IN endpoint:  
 Bit 0 for IN endpoint 0, bit 3 for IN endpoint 3  
 0: Masked interrupt  
 1: Unmasked interrupt

**OTG\_FS device control IN endpoint 0 control register (OTG\_FS\_DIEPCTL0)**

Address offset: 0x900

Reset value: 0x0000 0000

This section describes the OTG\_FS\_DIEPCTL0 register. Nonzero control endpoints use registers for endpoints 1–3.

31	30	29	28	27	26	25	24	23	22	21	20	19	18	17	16	15	14	13	12	11	10	9	8	7	6	5	4	3	2	1	0		
EPENA	EPDIS	Reserved		SNAK	CNAK	TXFNUM				STALL	Reserved	EPTYP		NAKSTS	Reserved	USBAEP	Reserved										MPSIZ						
r	r			w	w	rw	rw	rw	rw	rs		r	r	r		r																rw	rw

**Bit 31 EPENA:** Endpoint enable  
 The application sets this bit to start transmitting data on the endpoint 0.  
 The core clears this bit before setting any of the following interrupts on this endpoint:  
 – Endpoint disabled  
 – Transfer completed

**Bit 30 EPDIS:** Endpoint disable  
 The application sets this bit to stop transmitting data on an endpoint, even before the transfer for that endpoint is complete. The application must wait for the Endpoint disabled interrupt before treating the endpoint as disabled. The core clears this bit before setting the Endpoint disabled interrupt. The application must set this bit only if Endpoint enable is already set for this endpoint.

Bits 29:28 Reserved

**Bit 27 SNAK:** Set NAK  
 A write to this bit sets the NAK bit for the endpoint.  
 Using this bit, the application can control the transmission of NAK handshakes on an endpoint. The core can also set this bit for an endpoint after a SETUP packet is received on that endpoint.

**Bit 26 CNAK:** Clear NAK  
 A write to this bit clears the NAK bit for the endpoint.

Bits 25:22 **TXFNUM:** Tx FIFO number  
 This value is set to the FIFO number that is assigned to IN endpoint 0.

**Bit 21 STALL:** STALL handshake  
 The application can only set this bit, and the core clears it when a SETUP token is received for this endpoint. If a NAK bit, a Global IN NAK or Global OUT NAK is set along with this bit, the STALL bit takes priority.

Bit 20 Reserved

Bits 19:18 **EPTYP:** Endpoint type  
 Hardcoded to '00' for control.

Bit 17 **NAKSTS**: NAK status

Indicates the following:

- 0: The core is transmitting non-NAK handshakes based on the FIFO status
- 1: The core is transmitting NAK handshakes on this endpoint.

When this bit is set, either by the application or core, the core stops transmitting data, even if there are data available in the TxFIFO. Irrespective of this bit's setting, the core always responds to SETUP data packets with an ACK handshake.

Bit 16 Reserved

Bit 15 **USBAEP**: USB active endpoint

This bit is always set to 1, indicating that control endpoint 0 is always active in all configurations and interfaces.

Bits 14:2 Reserved

Bits 1:0 **MPSIZ**: Maximum packet size

The application must program this field with the maximum packet size for the current logical endpoint.

- 00: 64 bytes
- 01: 32 bytes
- 10: 16 bytes
- 11: 8 bytes

**OTG device endpoint-x control register (OTG\_FS\_DIEPCTLx) (x = 1..3, where x = Endpoint\_number)**

Address offset: 0x900 + (Endpoint\_number × 0x20)

Reset value: 0x0000 0000

The application uses this register to control the behavior of each logical endpoint other than endpoint 0.

31	30	29	28	27	26	25	24	23	22	21	20	19	18	17	16	15	14	13	12	11	10	9	8	7	6	5	4	3	2	1	0
EPENA	EPDIS	SODDFRM	SD0PID/SEVNFIRM	SNAK	CNAK	TXFNUM				Stall	Reserved	EPTYP	NAKSTS	EONUM/DPID	USBAEP	Reserved						MPSIZ									
rs	rs	w	w	w	w	rw	rw	rw	rw	rw/rs		rw	rw	r	r	rw						rw	rw	rw	rw	rw	rw	rw	rw	rw	rw

Bit 31 **EPENA**: Endpoint enable

- The application sets this bit to start transmitting data on an endpoint.  
 The core clears this bit before setting any of the following interrupts on this endpoint:
- SETUP phase done
  - Endpoint disabled
  - Transfer completed

- Bit 30 **EPDIS**: Endpoint disable  
The application sets this bit to stop transmitting/receiving data on an endpoint, even before the transfer for that endpoint is complete. The application must wait for the Endpoint disabled interrupt before treating the endpoint as disabled. The core clears this bit before setting the Endpoint disabled interrupt. The application must set this bit only if Endpoint enable is already set for this endpoint.
- Bit 29 **SODDFRM**: Set odd frame  
Applies to isochronous IN and OUT endpoints only.  
Writing to this field sets the Even/Odd frame (EONUM) field to odd frame.
- Bit 28 **SDOPID**: Set DATA0 PID  
Applies to interrupt/bulk IN endpoints only.  
Writing to this field sets the endpoint data PID (DPID) field in this register to DATA0.
- SEVNFRM**: Set even frame  
Applies to isochronous IN endpoints only.  
Writing to this field sets the Even/Odd frame (EONUM) field to even frame.
- Bit 27 **SNAK**: Set NAK  
A write to this bit sets the NAK bit for the endpoint.  
Using this bit, the application can control the transmission of NAK handshakes on an endpoint. The core can also set this bit for OUT endpoints on a Transfer completed interrupt, or after a SETUP is received on the endpoint.
- Bit 26 **CNAK**: Clear NAK  
A write to this bit clears the NAK bit for the endpoint.
- Bits 25:22 **TXFNUM**: TxFIFO number  
These bits specify the FIFO number associated with this endpoint. Each active IN endpoint must be programmed to a separate FIFO number.  
This field is valid only for IN endpoints.
- Bit 21 **STALL**: STALL handshake  
Applies to non-control, non-isochronous IN endpoints only (access type is rw).  
The application sets this bit to stall all tokens from the USB host to this endpoint. If a NAK bit, Global IN NAK, or Global OUT NAK is set along with this bit, the STALL bit takes priority. Only the application can clear this bit, never the core.  
Applies to control endpoints only (access type is rs).  
The application can only set this bit, and the core clears it, when a SETUP token is received for this endpoint. If a NAK bit, Global IN NAK, or Global OUT NAK is set along with this bit, the STALL bit takes priority. Irrespective of this bit's setting, the core always responds to SETUP data packets with an ACK handshake.
- Bit 20 Reserved
- Bits 19:18 **EPTYP**: Endpoint type  
This is the transfer type supported by this logical endpoint.  
00: Control  
01: Isochronous  
10: Bulk  
11: Interrupt



**Bit 17 NAKSTS:** NAK status

It indicates the following:

- 0: The core is transmitting non-NAK handshakes based on the FIFO status.
- 1: The core is transmitting NAK handshakes on this endpoint.

When either the application or the core sets this bit:

For non-isochronous IN endpoints: The core stops transmitting any data on an IN endpoint, even if there are data available in the TxFIFO.

For isochronous IN endpoints: The core sends out a zero-length data packet, even if there are data available in the TxFIFO.

Irrespective of this bit's setting, the core always responds to SETUP data packets with an ACK handshake.

**Bit 16 EONUM:** Even/odd frame

Applies to isochronous IN endpoints only.

Indicates the frame number in which the core transmits/receives isochronous data for this endpoint. The application must program the even/odd frame number in which it intends to transmit/receive isochronous data for this endpoint using the SEVNFRM and SODDFRM fields in this register.

- 0: Even frame
- 1: Odd frame

**DPID:** Endpoint data PID

Applies to interrupt/bulk IN endpoints only.

Contains the PID of the packet to be received or transmitted on this endpoint. The application must program the PID of the first packet to be received or transmitted on this endpoint, after the endpoint is activated. The application uses the SD0PID register field to program either DATA0 or DATA1 PID.

- 0: DATA0
- 1: DATA1

**Bit 15 USBAEP:** USB active endpoint

Indicates whether this endpoint is active in the current configuration and interface. The core clears this bit for all endpoints (other than EP 0) after detecting a USB reset. After receiving the SetConfiguration and SetInterface commands, the application must program endpoint registers accordingly and set this bit.

Bits 14:11 Reserved

**Bits 10:0 MPSIZ:** Maximum packet size

The application must program this field with the maximum packet size for the current logical endpoint. This value is in bytes.

**OTG\_FS device control OUT endpoint 0 control register (OTG\_FS\_DOEPCTL0)**

Address offset: 0xB00

Reset value: 0x0000 8000

This section describes the OTG\_FS\_DOEPCTL0 register. Nonzero control endpoints use registers for endpoints 1–3.

31	30	29	28	27	26	25	24	23	22	21	20	19	18	17	16	15	14	13	12	11	10	9	8	7	6	5	4	3	2	1	0
EPENA	EPDIS	Reserved		SNAK	CNAK	Reserved					Stall	SNPM	EPTYP		NAKSTS	Reserved	USBAEP	Reserved										MPSIZ			
w	r			w	w						rs	rw	r	r	r		r											r	r		

**Bit 31 EPENA:** Endpoint enable  
 The application sets this bit to start transmitting data on endpoint 0.  
 The core clears this bit before setting any of the following interrupts on this endpoint:

- SETUP phase done
- Endpoint disabled
- Transfer completed

**Bit 30 EPDIS:** Endpoint disable  
 The application cannot disable control OUT endpoint 0.

Bits 29:28 Reserved

**Bit 27 SNAK:** Set NAK  
 A write to this bit sets the NAK bit for the endpoint.  
 Using this bit, the application can control the transmission of NAK handshakes on an endpoint. The core can also set this bit on a Transfer completed interrupt, or after a SETUP is received on the endpoint.

**Bit 26 CNAK:** Clear NAK  
 A write to this bit clears the NAK bit for the endpoint.

Bits 25:22 Reserved

**Bit 21 STALL:** STALL handshake  
 The application can only set this bit, and the core clears it, when a SETUP token is received for this endpoint. If a NAK bit or Global OUT NAK is set along with this bit, the STALL bit takes priority. Irrespective of this bit’s setting, the core always responds to SETUP data packets with an ACK handshake.

**Bit 20 SNPM:** Snoop mode  
 This bit configures the endpoint to Snoop mode. In Snoop mode, the core does not check the correctness of OUT packets before transferring them to application memory.

Bits 19:18 **EPTYP:** Endpoint type  
 Hardcoded to 2'b00 for control.

Bit 17 **NAKSTS**: NAK status

Indicates the following:

- 0: The core is transmitting non-NAK handshakes based on the FIFO status.
- 1: The core is transmitting NAK handshakes on this endpoint.

When either the application or the core sets this bit, the core stops receiving data, even if there is space in the RxFIFO to accommodate the incoming packet. Irrespective of this bit's setting, the core always responds to SETUP data packets with an ACK handshake.

Bit 16 Reserved

Bit 15 **USBAEP**: USB active endpoint

This bit is always set to 1, indicating that a control endpoint 0 is always active in all configurations and interfaces.

Bits 14:2 Reserved

Bits 1:0 **MPSIZ**: Maximum packet size

The maximum packet size for control OUT endpoint 0 is the same as what is programmed in control IN endpoint 0.

- 00: 64 bytes
- 01: 32 bytes
- 10: 16 bytes
- 11: 8 bytes

**OTG\_FS device endpoint-x control register (OTG\_FS\_DOEPCCTLx) (x = 1..3, where x = Endpoint\_number)**

Address offset for OUT endpoints: 0xB00 + (Endpoint\_number × 0x20)

Reset value: 0x0000 0000

The application uses this register to control the behavior of each logical endpoint other than endpoint 0.

31	30	29	28	27	26	25	24	23	22	21	20	19	18	17	16	15	14	13	12	11	10	9	8	7	6	5	4	3	2	1	0
EPENA	EPDIS	SODDFRM/SD1PID	SD0PID/SEVNFRM	SNAK	CNAK	Reserved					Stall	SNPM	EPTYP		NAKSTS	EONUM/DPID	USBAEP	Reserved					MPSIZ								
rs	rs	w	w	w	w					rw/rs	rw	rw	rw	r	r	rw						rw	rw	rw	rw	rw	rw	rw	rw	rw	rw

Bit 31 **EPENA**: Endpoint enable

Applies to IN and OUT endpoints.

The application sets this bit to start transmitting data on an endpoint.

The core clears this bit before setting any of the following interrupts on this endpoint:

- SETUP phase done
- Endpoint disabled
- Transfer completed

- Bit 30 **EPDIS**: Endpoint disable  
The application sets this bit to stop transmitting/receiving data on an endpoint, even before the transfer for that endpoint is complete. The application must wait for the Endpoint disabled interrupt before treating the endpoint as disabled. The core clears this bit before setting the Endpoint disabled interrupt. The application must set this bit only if Endpoint enable is already set for this endpoint.
- Bit 29 **SD1PID**: Set DATA1 PID  
Applies to interrupt/bulk IN and OUT endpoints only. Writing to this field sets the endpoint data PID (DPID) field in this register to DATA1.  
**SODDFRM**: Set odd frame  
Applies to isochronous IN and OUT endpoints only. Writing to this field sets the Even/Odd frame (EONUM) field to odd frame.
- Bit 28 **SD0PID**: Set DATA0 PID  
Applies to interrupt/bulk OUT endpoints only.  
Writing to this field sets the endpoint data PID (DPID) field in this register to DATA0.  
**SEVNFRM**: Set even frame  
Applies to isochronous OUT endpoints only.  
Writing to this field sets the Even/Odd frame (EONUM) field to even frame.
- Bit 27 **SNAK**: Set NAK  
A write to this bit sets the NAK bit for the endpoint.  
Using this bit, the application can control the transmission of NAK handshakes on an endpoint. The core can also set this bit for OUT endpoints on a Transfer Completed interrupt, or after a SETUP is received on the endpoint.
- Bit 26 **CNAK**: Clear NAK  
A write to this bit clears the NAK bit for the endpoint.
- Bits 25:22 Reserved
- Bit 21 **STALL**: STALL handshake  
Applies to non-control, non-isochronous OUT endpoints only (access type is rw).  
The application sets this bit to stall all tokens from the USB host to this endpoint. If a NAK bit, Global IN NAK, or Global OUT NAK is set along with this bit, the STALL bit takes priority. Only the application can clear this bit, never the core.  
Applies to control endpoints only (access type is rs).  
The application can only set this bit, and the core clears it, when a SETUP token is received for this endpoint. If a NAK bit, Global IN NAK, or Global OUT NAK is set along with this bit, the STALL bit takes priority. Irrespective of this bit's setting, the core always responds to SETUP data packets with an ACK handshake.
- Bit 20 **SNPM**: Snoop mode  
This bit configures the endpoint to Snoop mode. In Snoop mode, the core does not check the correctness of OUT packets before transferring them to application memory.
- Bits 19:18 **EPTYP**: Endpoint type  
This is the transfer type supported by this logical endpoint.  
00: Control  
01: Isochronous  
10: Bulk  
11: Interrupt

**Bit 17 NAKSTS:** NAK status

Indicates the following:

- 0: The core is transmitting non-NAK handshakes based on the FIFO status.
- 1: The core is transmitting NAK handshakes on this endpoint.

When either the application or the core sets this bit:

The core stops receiving any data on an OUT endpoint, even if there is space in the RxFIFO to accommodate the incoming packet.

Irrespective of this bit's setting, the core always responds to SETUP data packets with an ACK handshake.

**Bit 16 EONUM:** Even/odd frame

Applies to isochronous IN and OUT endpoints only.

Indicates the frame number in which the core transmits/receives isochronous data for this endpoint. The application must program the even/odd frame number in which it intends to transmit/receive isochronous data for this endpoint using the SEVNFRM and SODDFRM fields in this register.

- 0: Even frame
- 1: Odd frame

**DPID:** Endpoint data PID

Applies to interrupt/bulk OUT endpoints only.

Contains the PID of the packet to be received or transmitted on this endpoint. The application must program the PID of the first packet to be received or transmitted on this endpoint, after the endpoint is activated. The application uses the SD0PID register field to program either DATA0 or DATA1 PID.

- 0: DATA0
- 1: DATA1

**Bit 15 USBAEP:** USB active endpoint

Indicates whether this endpoint is active in the current configuration and interface. The core clears this bit for all endpoints (other than EP 0) after detecting a USB reset. After receiving the SetConfiguration and SetInterface commands, the application must program endpoint registers accordingly and set this bit.

Bits 14:11 Reserved

**Bits 10:0 MPSIZ:** Maximum packet size

The application must program this field with the maximum packet size for the current logical endpoint. This value is in bytes.

**OTG\_FS device endpoint-x interrupt register (OTG\_FS\_DIEPINTx) (x = 0..3, where x = Endpoint\_number)**

Address offset: 0x908 + (Endpoint\_number × 0x20)

Reset value: 0x0000 0080

This register indicates the status of an endpoint with respect to USB- and AHB-related events. It is shown in *Figure 309*. The application must read this register when the IN endpoints interrupt bit of the Core interrupt register (IEPINT in OTG\_FS\_GINTSTS) is set. Before the application can read this register, it must first read the Device all endpoints interrupt (OTG\_FS\_DAINTE) register to get the exact endpoint number for the Device endpoint-x interrupt register. The application must clear the appropriate bit in this register to clear the corresponding bits in the OTG\_FS\_DAINTE and OTG\_FS\_GINTSTS registers.

31	30	29	28	27	26	25	24	23	22	21	20	19	18	17	16	15	14	13	12	11	10	9	8	7	6	5	4	3	2	1	0
Reserved																								TXFE	INEPNE	Reserved	ITTXFE	TOC	Reserved	EPDISD	XFFC
																								r	rc_w1/rw		rc_w1	rc_w1		rc_w1	rc_w1

Bits 31:8 Reserved

Bit 7 **TXFE**: Transmit FIFO empty

This interrupt is asserted when the TxFIFO for this endpoint is either half or completely empty. The half or completely empty status is determined by the TxFIFO Empty Level bit in the OTG\_FS\_GAHBCFG register (TXFELVL bit in OTG\_FS\_GAHBCFG).

Bit 6 **INEPNE**: IN endpoint NAK effective

This bit can be cleared when the application clears the IN endpoint NAK by writing to the CNAK bit in OTG\_FS\_DIEPCTLx.

This interrupt indicates that the core has sampled the NAK bit set (either by the application or by the core). The interrupt indicates that the IN endpoint NAK bit set by the application has taken effect in the core.

This interrupt does not guarantee that a NAK handshake is sent on the USB. A STALL bit takes priority over a NAK bit.

Bit 5 Reserved

Bit 4 **ITTXFE**: IN token received when TxFIFO is empty

Applies to non-periodic IN endpoints only.

Indicates that an IN token was received when the associated TxFIFO (periodic/non-periodic) was empty. This interrupt is asserted on the endpoint for which the IN token was received.

Bit 3 **TOC**: Timeout condition

Applies only to Control IN endpoints.

Indicates that the core has detected a timeout condition on the USB for the last IN token on this endpoint.

Bit 2 Reserved.

Bit 1 **EPDISD**: Endpoint disabled interrupt

This bit indicates that the endpoint is disabled per the application's request.

Bit 0 **XFRC**: Transfer completed interrupt  
 This field indicates that the programmed transfer is complete on the AHB as well as on the USB, for this endpoint.

**OTG\_FS device endpoint-x interrupt register (OTG\_FS\_DOEPINTx) (x = 0..3, where x = Endpoint\_number)**

Address offset: 0xB08 + (Endpoint\_number × 0x20)

Reset value: 0x0000 0080

This register indicates the status of an endpoint with respect to USB- and AHB-related events. It is shown in *Figure 309*. The application must read this register when the OUT Endpoints Interrupt bit of the OTG\_FS\_GINTSTS register (OEPINT bit in OTG\_FS\_GINTSTS) is set. Before the application can read this register, it must first read the OTG\_FS\_DAINTE register to get the exact endpoint number for the OTG\_FS\_DOEPINTx register. The application must clear the appropriate bit in this register to clear the corresponding bits in the OTG\_FS\_DAINTE and OTG\_FS\_GINTSTS registers.



Bits 31:7 Reserved

Bit 6 **B2BSTUP**: Back-to-back SETUP packets received  
 Applies to control OUT endpoint only.  
 This bit indicates that the core has received more than three back-to-back SETUP packets for this particular endpoint.

Bit 5 Reserved

Bit 4 **OTEPDIS**: OUT token received when endpoint disabled  
 Applies only to control OUT endpoints.  
 Indicates that an OUT token was received when the endpoint was not yet enabled. This interrupt is asserted on the endpoint for which the OUT token was received.

Bit 3 **STUP**: SETUP phase done  
 Applies to control OUT endpoint only.  
 Indicates that the SETUP phase for the control endpoint is complete and no more back-to-back SETUP packets were received for the current control transfer. On this interrupt, the application can decode the received SETUP data packet.

Bit 2 Reserved

Bit 1 **EPDISD**: Endpoint disabled interrupt  
 This bit indicates that the endpoint is disabled per the application's request.

Bit 0 **XFRC**: Transfer completed interrupt  
 This field indicates that the programmed transfer is complete on the AHB as well as on the USB, for this endpoint.

**OTG\_FS device IN endpoint 0 transfer size register (OTG\_FS\_DIEPTSIZ0)**

Address offset: 0x910

Reset value: 0x0000 0000

The application must modify this register before enabling endpoint 0. Once endpoint 0 is enabled using the endpoint enable bit in the device control endpoint 0 control registers (EPENA in OTG\_FS\_DIEPCTL0), the core modifies this register. The application can only read this register once the core has cleared the Endpoint enable bit.

Nonzero endpoints use the registers for endpoints 1–3.

31	30	29	28	27	26	25	24	23	22	21	20	19	18	17	16	15	14	13	12	11	10	9	8	7	6	5	4	3	2	1	0
Reserved											PKTCNT		Reserved											XFRSIZ							
											rw	rw												rw	rw	rw	rw	rw	rw	rw	

Bits 31:21 Reserved

Bits 20:19 **PKTCNT**: Packet count

Indicates the total number of USB packets that constitute the Transfer Size amount of data for endpoint 0.

This field is decremented every time a packet (maximum size or short packet) is read from the Tx FIFO.

Bits 18:7 Reserved

Bits 6:0 **XFRSIZ**: Transfer size

Indicates the transfer size in bytes for endpoint 0. The core interrupts the application only after it has exhausted the transfer size amount of data. The transfer size can be set to the maximum packet size of the endpoint, to be interrupted at the end of each packet.

The core decrements this field every time a packet from the external memory is written to the Tx FIFO.



**OTG\_FS device OUT endpoint 0 transfer size register (OTG\_FS\_DOEPTSIZ0)**

Address offset: 0xB10

Reset value: 0x0000 0000

The application must modify this register before enabling endpoint 0. Once endpoint 0 is enabled using the Endpoint enable bit in the OTG\_FS\_DOEPCCTL0 registers (EPENA bit in OTG\_FS\_DOEPCCTL0), the core modifies this register. The application can only read this register once the core has cleared the Endpoint enable bit.

Nonzero endpoints use the registers for endpoints 1–3.

31	30	29	28	27	26	25	24	23	22	21	20	19	18	17	16	15	14	13	12	11	10	9	8	7	6	5	4	3	2	1	0
Reserved	STUPCNT		Reserved										PKTCNT	Reserved										XFRSIZ							
	rw	rw												rw											rw	rw	rw	rw	rw	rw	rw

Bit 31 Reserved

Bits 30:29 **STUPCNT**: SETUP packet count

This field specifies the number of back-to-back SETUP data packets the endpoint can receive.

- 01: 1 packet
- 10: 2 packets
- 11: 3 packets

Bits 28:20 Reserved

Bit 19 **PKTCNT**: Packet count

This field is decremented to zero after a packet is written into the RxFIFO.

Bits 18:7 Reserved

Bits 6:0 **XFRSIZ**: Transfer size

Indicates the transfer size in bytes for endpoint 0. The core interrupts the application only after it has exhausted the transfer size amount of data. The transfer size can be set to the maximum packet size of the endpoint, to be interrupted at the end of each packet.

The core decrements this field every time a packet is read from the RxFIFO and written to the external memory.

**OTG\_FS device endpoint-x transfer size register (OTG\_FS\_DIEPTSIZx)  
(x = 1..3, where x = Endpoint\_number)**

Address offset: 0x910 + (Endpoint\_number × 0x20)

Reset value: 0x0000 0000

The application must modify this register before enabling the endpoint. Once the endpoint is enabled using the Endpoint enable bit in the OTG\_FS\_DIEPCTLx registers (EPENA bit in OTG\_FS\_DIEPCTLx), the core modifies this register. The application can only read this register once the core has cleared the Endpoint enable bit.

	31	30	29	28	27	26	25	24	23	22	21	20	19	18	17	16	15	14	13	12	11	10	9	8	7	6	5	4	3	2	1	0
Reserved	MCNT		PKTCNT											XFRSIZ																		
	rw/rw	rw/rw	rw	rw	rw	rw	rw	rw	rw	rw	rw	rw	rw	rw	rw	rw	rw	rw	rw	rw	rw	rw	rw	rw	rw	rw	rw	rw	rw	rw	rw	rw

Bit 31 Reserved

Bits 30:29 **MCNT**: Multi count

For periodic IN endpoints, this field indicates the number of packets that must be transmitted per frame on the USB. The core uses this field to calculate the data PID for isochronous IN endpoints.

- 01: 1 packet
- 10: 2 packets
- 11: 3 packets

Bit 28:19 **PKTCNT**: Packet count

Indicates the total number of USB packets that constitute the Transfer Size amount of data for this endpoint.

This field is decremented every time a packet (maximum size or short packet) is read from the Tx FIFO.

Bits 18:0 **XFRSIZ**: Transfer size

This field contains the transfer size in bytes for the current endpoint. The core only interrupts the application after it has exhausted the transfer size amount of data. The transfer size can be set to the maximum packet size of the endpoint, to be interrupted at the end of each packet.

The core decrements this field every time a packet from the external memory is written to the Tx FIFO.

**OTG\_FS device IN endpoint transmit FIFO status register (OTG\_FS\_DTXFSTx) (x = 0..3, where x = Endpoint\_number)**

Address offset for IN endpoints: 0x918 + (Endpoint\_number × 0x20) This read-only register contains the free space information for the Device IN endpoint Tx FIFO.

31	30	29	28	27	26	25	24	23	22	21	20	19	18	17	16	15	14	13	12	11	10	9	8	7	6	5	4	3	2	1	0																
Reserved																INEPTFSAV																															
																r	r	r	r	r	r	r	r	r	r	r	r	r	r	r	r	r	r	r	r	r	r	r	r	r	r	r	r	r	r	r	r

31:16 Reserved

15:0 **INEPTFSAV**: IN endpoint Tx FIFO space available

Indicates the amount of free space available in the Endpoint Tx FIFO.

Values are in terms of 32-bit words:

- 0x0: Endpoint Tx FIFO is full
- 0x1: 1 word available
- 0x2: 2 words available
- 0xn: n words available
- Others: Reserved

**OTG\_FS device OUT endpoint-x transfer size register (OTG\_FS\_DOEPTSIZx) (x = 1..3, where x = Endpoint\_number)**

Address offset: 0xB10 + (Endpoint\_number × 0x20)

Reset value: 0x0000 0000

The application must modify this register before enabling the endpoint. Once the endpoint is enabled using Endpoint Enable bit of the OTG\_FS\_DOEPCTLx registers (EPENA bit in OTG\_FS\_DOEPCTLx), the core modifies this register. The application can only read this register once the core has cleared the Endpoint enable bit.

31	30	29	28	27	26	25	24	23	22	21	20	19	18	17	16	15	14	13	12	11	10	9	8	7	6	5	4	3	2	1	0
Reserved	RXDPID/S TUPCNT		PKTCNT										XFRSIZ																		
	rw/r/ rw	rw/r/ rw	rw	rw	rw	rw	rw	rw	rw	rw	rw	rw	rw	rw	rw	rw	rw	rw	rw	rw	rw	rw	rw	rw	rw	rw	rw	rw	rw	rw	rw

Bit 31 Reserved

Bits 30:29 **RXDPID**: Received data PID

Applies to isochronous OUT endpoints only.

This is the data PID received in the last packet for this endpoint.

- 00: DATA0
- 01: DATA2
- 10: DATA1
- 11: MDATA

**STUPCNT:** SETUP packet count

Applies to control OUT Endpoints only.

This field specifies the number of back-to-back SETUP data packets the endpoint can receive.

- 01: 1 packet
- 10: 2 packets
- 11: 3 packets

Bit 28:19 **PKTCNT:** Packet count

Indicates the total number of USB packets that constitute the Transfer Size amount of data for this endpoint.

This field is decremented every time a packet (maximum size or short packet) is written to the RxFIFO.

Bits 18:0 **XFRSIZ:** Transfer size

This field contains the transfer size in bytes for the current endpoint. The core only interrupts the application after it has exhausted the transfer size amount of data. The transfer size can be set to the maximum packet size of the endpoint, to be interrupted at the end of each packet.

The core decrements this field every time a packet is read from the RxFIFO and written to the external memory.

### 27.15.5 OTG\_FS power and clock gating control register (OTG\_FS\_PCGCCTL)

Address offset: 0xE00

Reset value: 0x0000 0000

This register is available in Host and Device modes.

31	30	29	28	27	26	25	24	23	22	21	20	19	18	17	16	15	14	13	12	11	10	9	8	7	6	5	4	3	2	1	0
Reserved																									PHYSUSP	Reserved		GATEHCLK	STPPCLK		
																									rw			rw	rw		

Bit 31:5 Reserved

Bit 4 **PHYSUSP:** PHY Suspended

Indicates that the PHY has been suspended. This bit is updated once the PHY is suspended after the application has set the STPPCLK bit (bit 0).

Bits 3:2 Reserved

Bit 1 **GATEHCLK:** Gate HCLK

The application sets this bit to gate HCLK to modules other than the AHB Slave and Master and wakeup logic when the USB is suspended or the session is not valid. The application clears this bit when the USB is resumed or a new session starts.

Bit 0 **STPPCLK:** Stop PHY clock

The application sets this bit to stop the PHY clock when the USB is suspended, the session is not valid, or the device is disconnected. The application clears this bit when the USB is resumed or a new session starts.

### 27.15.6 OTG\_FS register map

The table below gives the USB OTG register map and reset values.

**Table 202. OTG\_FS register map and reset values**

Offset	Register	31	30	29	28	27	26	25	24	23	22	21	20	19	18	17	16	15	14	13	12	11	10	9	8	7	6	5	4	3	2	1	0
0x000	OTG_FS_GOT_GCTL	Reserved												BSVLD	ASVLD	DBCT	CIDSTS	Reserved					DHNPEN	HSHNPEN	HNPREQ	HNGSCS	Reserved					SRQ	SRQSCS
	Reset value													0	0	0	1						0	0	0	0						0	0
0x004	OTG_FS_GOT_GINT	Reserved												DBCONE	ADTOCHG	HNGDET	Reserved					HNSSCHG			SRSSCHG	Reserved					SEDET	Res.	
	Reset value													0	0	0						0			0						0		
0x008	OTG_FS_GAH_BCFG	Reserved																											PTXFELVL	TXFELVL	Reserved		GINTMSK
	Reset value																												0	0			0
0x00C	OTG_FS_GUS_BCFG	CTXPKT	FDMOD	FHM0D	Reserved												TRDT			HNPCAP	SRPCAP	PHYSEL	Reserved					TOTAL					
	Reset value																0 1 0 1			0	0	1						0 0 0					
0x010	OTG_FS_GRST_CTL	AHBIDL	Reserved												TXFNUM					TXFFLSH	RXFFLSH	Reserved	FCRST	HSRST	CSRST								
	Reset value	1													0 0 0					0	0	0	0	0	0	0							
0x014	OTG_FS_GINT_STS	WKJINT	SRQINT	DISCINT	CIDSCHG	Reserved	PTXFE	HCINT	HPRTINT	Reserved	IPXFRM/INCOMPISOOOUT	IISOXFR	OEPIINT	IEPIINT	Reserved	EOPF	ISOODRPM	ENUMDNE	USBRST	USBSUSP	ESUSP	Reserved	GOUTNAKEFF	GINAKEFF	NPTXFE	RXFLVL	SOF	OTGINT	MMIS	CMOD			
	Reset value	0	0	0	0		1	0	0		0	0	0	0		0	0	0	0	0	0		0	0	1	0	0	0	0	0			
0x018	OTG_FS_GINT_MSK	WUJIM	SRQIM	DISCINT	CIDSCHGM	Reserved	PTXFEM	HCIM	PRTIM	Reserved	IPXFRM/IISOXFRM	IISOXFRM	OEPIINT	IEPIINT	EPMISM	Reserved	EOPFM	ISOODRPM	ENUMDNEM	USBRST	USBSUSPM	ESUSPM	Reserved	GONAKEFFM	GINAKEFFM	NPTXFEM	RXFLVLM	SOFM	OTGINT	MMISM	Reserved		
	Reset value	0	0	0	0		0	0	0		0	0	0	0	0		0	0	0	0	0	0		0	0	0	0	0	0	0	0		
0x01C	OTG_FS_GRXS_TSR (Host mode)	Reserved												PKTSTS			DPID	BCNT					CHNUM										
	Reset value													0 0 0 0			0	0 0 0 0 0 0 0 0 0 0 0 0					0 0 0										
0x01C	OTG_FS_GRXS_TSPR (Device mode)	Reserved								FRMNUM			PKTSTS			DPID	BCNT					EPNUM											
	Reset value									0 0 0 0 0			0 0 0 0 0			0 0	0 0 0 0 0 0 0 0 0 0 0 0					0 0 0 0 0											
0x020	OTG_FS_GRXS_TSR (Host mode)	Reserved												PKTSTS			DPID	BCNT					CHNUM										
	Reset value													0 0 0 0 0			0	0 0 0 0 0 0 0 0 0 0 0 0					0 0 0 0										
0x020	OTG_FS_GRXS_TSPR (Device mode)	Reserved								FRMNUM			PKTSTS			DPID	BCNT					EPNUM											
	Reset value									0 0 0 0 0			0 0 0 0 0			0 0	0 0 0 0 0 0 0 0 0 0 0 0					0 0 0 0 0											
0x024	OTG_FS_GRXF_SIZ	Reserved																	RXFD														
	Reset value																		0 0 0 0 0 0 0 0 1 0 0 0 0 0 0 0 0 0 0 0 0 0 0 0														



Table 202. OTG\_FS register map and reset values (continued)

Offset	Register	31	30	29	28	27	26	25	24	23	22	21	20	19	18	17	16	15	14	13	12	11	10	9	8	7	6	5	4	3	2	1	0	
0x028	OTG_FS_HNPTXFSIZ/ OTG_FS_DIEPTXF0	NPTXFD/TX0FD														NPTXFSA/TX0FSA																		
	Reset value	0	0	0	0	0	0	0	0	0	0	0	0	0	0	0	0	0	0	0	0	0	0	0	1	0	0	0	0	0	0	0	0	0
0x02C	OTG_FS_HNPTXSTS	Res.	NPTXQTOP							NPTQXSAV							NPTXFSAV																	
	Reset value		0	0	0	0	0	0	0	0	0	0	0	0	0	0	0	0	0	0	0	0	0	0	0	1	0	0	0	0	0	0	0	0
0x038	OTG_FS_GCCFG	Reserved														ISOOUTEN	VBUSSEN	VBUSASEN	Reserved	.PWRDWN	Reserved													
	Reset value	0	0	0	0	0	0	0	0	0	0	0	0	0	0	0	0	0	0	0	0	0	0	0	0	0	0	0	0	0	0	0	0	0
0x03C	OTG_FS_CID	PRODUCT_ID																																
	Reset value	0	0	0	0	0	0	0	0	0	0	0	0	0	0	0	0	0	0	0	0	0	0	0	0	0	0	0	0	0	0	0	0	0
0x100	OTG_FS_HPTXFSIZ	PTXFSIZ														PTXSA																		
	Reset value	0	0	0	0	0	0	1	1	1	0	1	1	0	1	0	0	0	0	0	0	1	0	0	0	0	0	0	1	0	0	1	0	0
0x104	OTG_FS_DIEPTXF1	INEPTXFD														INEPTXSA																		
	Reset value	0	0	0	0	0	0	1	0	0	0	0	0	0	0	0	0	0	0	0	0	0	0	1	0	0	0	0	0	0	0	0	0	0
0x108	OTG_FS_DIEPTXF2	INEPTXFD														INEPTXSA																		
	Reset value	0	0	0	0	0	0	1	0	0	0	0	0	0	0	0	0	0	0	0	0	0	0	1	0	0	0	0	0	0	0	0	0	0
0x10C	OTG_FS_DIEPTXF3	INEPTXFD														INEPTXSA																		
	Reset value	0	0	0	0	0	0	1	0	0	0	0	0	0	0	0	0	0	0	0	0	0	0	1	0	0	0	0	0	0	0	0	0	0
0x400	OTG_FS_HCFG	Reserved																												FSLSS	FSLSPCS			
	Reset value	0	0	0	0	0	0	0	0	0	0	0	0	0	0	0	0	0	0	0	0	0	0	0	0	0	0	0	0	0	0	0	0	0
0x404	OTG_FS_HFIR	Reserved														FRIVL																		
	Reset value	1	1	1	0	1	0	1	0	1	0	0	1	1	0	0	0	0	0	0	1	1	0	0	1	1	0	0	0	0	0	0	0	
0x408	OTG_FS_HFNUM	FTREM														FRNUM																		
	Reset value	0	0	0	0	0	0	0	0	0	0	0	0	0	0	0	0	0	0	0	1	1	1	1	1	1	1	1	1	1	1	1	1	1
0x410	OTG_FS_HPTXSTS	PTXQTOP							PTXQSAV							PTXFSAVL																		
	Reset value	0	0	0	0	0	0	0	0	Y	Y	Y	Y	Y	Y	Y	Y	Y	Y	Y	Y	Y	Y	Y	Y	Y	Y	Y	Y	Y	Y	Y	Y	Y
0x414	OTG_FS_HAINT	Reserved														HAINT																		
	Reset value	0	0	0	0	0	0	0	0	0	0	0	0	0	0	0	0	0	0	0	0	0	0	0	0	0	0	0	0	0	0	0	0	0
0x418	OTG_FS_HAINTMSK	Reserved														HAINTM																		
	Reset value	0	0	0	0	0	0	0	0	0	0	0	0	0	0	0	0	0	0	0	0	0	0	0	0	0	0	0	0	0	0	0	0	0
0x440	OTG_FS_HPRT	Reserved														PSPD	PTCTL		PPWR	PLSTS	Reserved	PRST	PSUSP	PRES	POCCHNG	POCA	PENCHNG	PENA	PCDET	PCSTS				
	Reset value	0	0	0	0	0	0	0	0	0	0	0	0	0	0	0	0	0	0	0	0	0	0	0	0	0	0	0	0	0	0	0	0	0
0x500	OTG_FS_HCC HAR0	CHENA	CHDIS	ODDFRM	DAD							MCNT	EPTYP	LSDEV	Reserved	EPDIR	EPNUM		MPSIZ															
	Reset value	0	0	0	0	0	0	0	0	0	0	0	0	0	0	0	0	0	0	0	0	0	0	0	0	0	0	0	0	0	0	0	0	0
0x520	OTG_FS_HCC HAR1	CHENA	CHDIS	ODDFRM	DAD							MCNT	EPTYP	LSDEV	Reserved	EPDIR	EPNUM		MPSIZ															
	Reset value	0	0	0	0	0	0	0	0	0	0	0	0	0	0	0	0	0	0	0	0	0	0	0	0	0	0	0	0	0	0	0	0	0
0x540	OTG_FS_HCC HAR2	CHENA	CHDIS	ODDFRM	DAD							MCNT	EPTYP	LSDEV	Reserved	EPDIR	EPNUM		MPSIZ															
	Reset value	0	0	0	0	0	0	0	0	0	0	0	0	0	0	0	0	0	0	0	0	0	0	0	0	0	0	0	0	0	0	0	0	0



Table 202. OTG\_FS register map and reset values (continued)

Offset	Register	31	30	29	28	27	26	25	24	23	22	21	20	19	18	17	16	15	14	13	12	11	10	9	8	7	6	5	4	3	2	1	0
0x560	OTG_FS_HCC HAR3	CHENA	CHDIS	ODDFRM	DAD						MCNT		EPTYP	LSDEV	Reserved	EPDIR	EPNUM			MPSIZ													
	Reset value	0	0	0	0	0	0	0	0	0	0	0	0	0	0	0	0	0	0	0	0	0	0	0	0	0	0	0	0	0	0	0	0
0x580	OTG_FS_HCC HAR4	CHENA	CHDIS	ODDFRM	DAD						MCNT		EPTYP	LSDEV	Reserved	EPDIR	EPNUM			MPSIZ													
	Reset value	0	0	0	0	0	0	0	0	0	0	0	0	0	0	0	0	0	0	0	0	0	0	0	0	0	0	0	0	0	0	0	0
0x5A0	OTG_FS_HCC HAR5	CHENA	CHDIS	ODDFRM	DAD						MCNT		EPTYP	LSDEV	Reserved	EPDIR	EPNUM			MPSIZ													
	Reset value	0	0	0	0	0	0	0	0	0	0	0	0	0	0	0	0	0	0	0	0	0	0	0	0	0	0	0	0	0	0	0	0
0x5C0	OTG_FS_HCC HAR6	CHENA	CHDIS	ODDFRM	DAD						MCNT		EPTYP	LSDEV	Reserved	EPDIR	EPNUM			MPSIZ													
	Reset value	0	0	0	0	0	0	0	0	0	0	0	0	0	0	0	0	0	0	0	0	0	0	0	0	0	0	0	0	0	0	0	0
0x5E0	OTG_FS_HCC HAR7	CHENA	CHDIS	ODDFRM	DAD						MCNT		EPTYP	LSDEV	Reserved	EPDIR	EPNUM			MPSIZ													
	Reset value	0	0	0	0	0	0	0	0	0	0	0	0	0	0	0	0	0	0	0	0	0	0	0	0	0	0	0	0	0	0	0	0
0x508	OTG_FS_HCIN T0	Reserved																				DTERR	FRMOR	BBERR	TXERR	Reserved	ACK	NAK	STALL	Reserved	CHH	XFRC	
	Reset value																					0	0	0	0	0	0	0	0	0	0	0	0
0x528	OTG_FS_HCIN T1	Reserved																				DTERR	FRMOR	BBERR	TXERR	Reserved	ACK	NAK	STALL	Reserved	CHH	XFRC	
	Reset value																					0	0	0	0	0	0	0	0	0	0	0	
0x548	OTG_FS_HCIN T2	Reserved																				DTERR	FRMOR	BBERR	TXERR	Reserved	ACK	NAK	STALL	Reserved	CHH	XFRC	
	Reset value																					0	0	0	0	0	0	0	0	0	0	0	
0x568	OTG_FS_HCIN T3	Reserved																				DTERR	FRMOR	BBERR	TXERR	Reserved	ACK	NAK	STALL	Reserved	CHH	XFRC	
	Reset value																					0	0	0	0	0	0	0	0	0	0	0	
0x588	OTG_FS_HCIN T4	Reserved																				DTERR	FRMOR	BBERR	TXERR	Reserved	ACK	NAK	STALL	Reserved	CHH	XFRC	
	Reset value																					0	0	0	0	0	0	0	0	0	0	0	
0x5A8	OTG_FS_HCIN T5	Reserved																				DTERR	FRMOR	BBERR	TXERR	Reserved	ACK	NAK	STALL	Reserved	CHH	XFRC	
	Reset value																					0	0	0	0	0	0	0	0	0	0	0	
0x5C8	OTG_FS_HCIN T6	Reserved																				DTERR	FRMOR	BBERR	TXERR	Reserved	ACK	NAK	STALL	Reserved	CHH	XFRC	
	Reset value																					0	0	0	0	0	0	0	0	0	0	0	
0x5E8	OTG_FS_HCIN T7	Reserved																				DTERR	FRMOR	BBERR	TXERR	Reserved	ACK	NAK	STALL	Reserved	CHH	XFRC	
	Reset value																					0	0	0	0	0	0	0	0	0	0	0	
0x50C	OTG_FS_HCIN TMSK0	Reserved																				DTERR	FRMORM	BBERRM	TXERRM	NYET	ACKM	NAKM	STALLM	Reserved	CHHM	XFRCM	
	Reset value																					0	0	0	0	0	0	0	0	0	0	0	
0x52C	OTG_FS_HCIN TMSK1	Reserved																				DTERRM	FRMORM	BBERRM	TXERRM	NYET	ACKM	NAKM	STALLM	Reserved	CHHM	XFRCM	
	Reset value																					0	0	0	0	0	0	0	0	0	0	0	

Table 202. OTG\_FS register map and reset values (continued)

Offset	Register	31	30	29	28	27	26	25	24	23	22	21	20	19	18	17	16	15	14	13	12	11	10	9	8	7	6	5	4	3	2	1	0																	
0x54C	OTG_FS_HGIN_TMSK2	Reserved																				DTERRM	FRMORM	BBERRM	TXERRM	NYET	ACKM	NAKM	STALLM	Reserved	CHHM	XFRM																		
	Reset value																					0	0	0	0	0	0	0	0	0	0	0	0	0	0	0	0	0	0	0	0	0	0	0	0	0	0	0	0	0
0x56C	OTG_FS_HGIN_TMSK3	Reserved																				DTERRM	FRMORM	BBERRM	TXERRM	NYET	ACKM	NAKM	STALLM	Reserved	CHHM	XFRM																		
	Reset value																					0	0	0	0	0	0	0	0	0	0	0	0	0	0	0	0	0	0	0	0	0	0	0	0	0	0	0	0	0
0x58C	OTG_FS_HGIN_TMSK4	Reserved																				DTERRM	FRMORM	BBERRM	TXERRM	NYET	ACKM	NAKM	STALLM	Reserved	CHHM	XFRM																		
	Reset value																					0	0	0	0	0	0	0	0	0	0	0	0	0	0	0	0	0	0	0	0	0	0	0	0	0	0	0	0	0
0x5AC	OTG_FS_HGIN_TMSK5	Reserved																				DTERRM	FRMORM	BBERRM	TXERRM	NYET	ACKM	NAKM	STALLM	Reserved	CHHM	XFRM																		
	Reset value																					0	0	0	0	0	0	0	0	0	0	0	0	0	0	0	0	0	0	0	0	0	0	0	0	0	0	0	0	0
0x5CC	OTG_FS_HGIN_TMSK6	Reserved																				DTERRM	FRMORM	BBERRM	TXERRM	NYET	ACKM	NAKM	STALLM	Reserved	CHHM	XFRM																		
	Reset value																					0	0	0	0	0	0	0	0	0	0	0	0	0	0	0	0	0	0	0	0	0	0	0	0	0	0	0	0	0
0x5EC	OTG_FS_HGIN_TMSK7	Reserved																				DTERRM	FRMORM	BBERRM	TXERRM	NYET	ACKM	NAKM	STALLM	Reserved	CHHM	XFRM																		
	Reset value																					0	0	0	0	0	0	0	0	0	0	0	0	0	0	0	0	0	0	0	0	0	0	0	0	0	0	0	0	0
0x510	OTG_FS_HCTS_IZ0	Reserved	DPID	PKTCNT												XFRSIZ																																		
	Reset value	Reserved	0	0	0	0	0	0	0	0	0	0	0	0	0	0	0	0	0	0	0	0	0	0	0	0	0	0	0	0	0	0	0	0																
0x530	OTG_FS_HCTS_IZ1	Reserved	DPID	PKTCNT												XFRSIZ																																		
	Reset value	Reserved	0	0	0	0	0	0	0	0	0	0	0	0	0	0	0	0	0	0	0	0	0	0	0	0	0	0	0	0	0	0	0	0																
0x550	OTG_FS_HCTS_IZ2	Reserved	DPID	PKTCNT												XFRSIZ																																		
	Reset value	Reserved	0	0	0	0	0	0	0	0	0	0	0	0	0	0	0	0	0	0	0	0	0	0	0	0	0	0	0	0	0	0	0	0																
0x570	OTG_FS_HCTS_IZ3	Reserved	DPID	PKTCNT												XFRSIZ																																		
	Reset value	Reserved	0	0	0	0	0	0	0	0	0	0	0	0	0	0	0	0	0	0	0	0	0	0	0	0	0	0	0	0	0	0	0	0																
0x590	OTG_FS_HCTS_IZ4	Reserved	DPID	PKTCNT												XFRSIZ																																		
	Reset value	Reserved	0	0	0	0	0	0	0	0	0	0	0	0	0	0	0	0	0	0	0	0	0	0	0	0	0	0	0	0	0	0	0	0																
0x5B0	OTG_FS_HCTS_IZ5	Reserved	DPID	PKTCNT												XFRSIZ																																		
	Reset value	Reserved	0	0	0	0	0	0	0	0	0	0	0	0	0	0	0	0	0	0	0	0	0	0	0	0	0	0	0	0	0	0	0	0																
0x5D0	OTG_FS_HCTS_IZ6	Reserved	DPID	PKTCNT												XFRSIZ																																		
	Reset value	Reserved	0	0	0	0	0	0	0	0	0	0	0	0	0	0	0	0	0	0	0	0	0	0	0	0	0	0	0	0	0	0	0	0																
0x5F0	OTG_FS_HCTS_IZ7	Reserved	DPID	PKTCNT												XFRSIZ																																		
	Reset value	Reserved	0	0	0	0	0	0	0	0	0	0	0	0	0	0	0	0	0	0	0	0	0	0	0	0	0	0	0	0	0	0	0	0																
0x800	OTG_FS_DCFG	Reserved																				PFIVL		DAD						Reserved	INZLSOHSK	DSPD																		
	Reset value																					0	0	0	0	0	0	0	0	0	0	0	0	0	0	0	0	0	0	0	0	0	0	0	0	0	0	0	0	0





Table 202. OTG\_FS register map and reset values (continued)

Offset	Register	31	30	29	28	27	26	25	24	23	22	21	20	19	18	17	16	15	14	13	12	11	10	9	8	7	6	5	4	3	2	1	0															
0x804	OTG_FS_DCTL	Reserved																				POP	PRGDNE	CGONAK	SGONAK	CGINAK	SGINAK	TCTL				GONSTS	GINSTS	SDIS	FWUSIG													
	Reset value	0																				0	0	0	0	0	0	0	0	0	0	0	0	0	0	0	0	0	0	0	0	0	0	0	0	0	0	0
0x808	OTG_FS_DSTS	Reserved										FNSOF						Reserved				EERR	ENUMSPD	SUSPSTS																								
	Reset value	0										0						0				0	0	0	0																							
0x810	OTG_FS_DIEPMSK	Reserved																				INENEM	INENMM	ITTXFEMSK	TOM	Reserved	EPDM	XFRM																				
	Reset value	0																				0	0	0	0	0	0	0																				
0x814	OTG_FS_DOEPMASK	Reserved																				OTEPDM	STUPM	Reserved	EPDM	XFRM																						
	Reset value	0																				0	0	0	0	0																						
0x818	OTG_FS_DAINT	OEPINT										IEPINT																																				
	Reset value	0	0	0	0	0	0	0	0	0	0	0	0	0	0	0	0	0	0	0	0	0	0	0	0	0	0	0	0	0	0	0																
0x81C	OTG_FS_DAINTMSK	OEPM										IEPM																																				
	Reset value	0	0	0	0	0	0	0	0	0	0	0	0	0	0	0	0	0	0	0	0	0	0	0	0	0	0	0	0	0	0	0																
0x828	OTG_FS_DVBUSDIS	Reserved										VBUSDT																																				
	Reset value	0										0 0 0 1 0 1 1 1 1 1 1 0 1 0 1 1 1																																				
0x82C	OTG_FS_DVBUSPULSE	Reserved										DVBUSP																																				
	Reset value	0										0 1 0 1 1 0 1 1 1 1 0 0 0																																				
0x834	OTG_FS_DIEPEMPMSK	Reserved										INEPTXFEM																																				
	Reset value	0										0 0																																				
0x900	OTG_FS_DIEPCTL0	EPENA	EPDIS	Reserved	SNAK	CNAK	TXFNUM	Stall	Reserved	EPTYP	NAKSTS	Reserved	USBAEP	Reserved										MPSIZ																								
	Reset value	0	0	0	0	0	0 0 0 0 0 0	0	0	0	0	0	0	1	0										0 0																							
0x918	TG_FS_DTXFSTS0	Reserved										INEPTFSAV																																				
	Reset value	0										0 0 0 0 0 0 0 1 0																																				
0x920	OTG_FS_DIEPCTL1	EPENA	EPDIS	SODDFRM/SD1PID	SD0PID/SEVNFNFRM	SNAK	CNAK	TXFNUM	Stall	Reserved	EPTYP	NAKSTS	EONUM/DPID	USBAEP	Reserved										MPSIZ																							
	Reset value	0	0	0	0	0	0 0 0 0 0 0	0	0	0	0	0	0	0	0										0 0																							
0x938	TG_FS_DTXFSTS1	Reserved										INEPTFSAV																																				
	Reset value	0										0 0 0 0 0 0 0 1 0																																				
0x940	OTG_FS_DIEPCTL2	EPENA	EPDIS	SODDFRM	SD0PID/SEVNFNFRM	SNAK	CNAK	TXFNUM	Stall	Reserved	EPTYP	NAKSTS	EONUM/DPID	USBAEP	Reserved										MPSIZ																							
	Reset value	0	0	0	0	0	0 0 0 0 0 0	0	0	0	0	0	0	0	0										0 0																							
0x958	TG_FS_DTXFSTS2	Reserved										INEPTFSAV																																				
	Reset value	0										0 0 0 0 0 0 0 1 0																																				

Table 202. OTG\_FS register map and reset values (continued)

Offset	Register	31	30	29	28	27	26	25	24	23	22	21	20	19	18	17	16	15	14	13	12	11	10	9	8	7	6	5	4	3	2	1	0
0x960	OTG_FS_DIEP CTL3	EPENA	EPDIS	SODDFRM	SD0PID/SEVNFRM	SNAK	CNAK	TXFNUM				Stall	Reserved	EPTYP	NAKSTS	EONUM/DPID	USBAEP	Reserved				MPSIZ											
	Reset value	0	0	0	0	0	0	0	0	0	0	0	0	0	0	0	0	0	0	0	0	0	0	0	0	0	0	0	0	0	0	0	0
0x978	TG_FS_DTXFS TS3	Reserved														INEPTFSAV																	
	Reset value	0														0 0 0 0 0 0 0 1 0 0 0 0 0 0 0 0 0 0 0 0																	
0xB00	OTG_FS_DOEP CTL0	EPENA	EPDIS	Reserved	Reserved	SNAK	CNAK	Reserved				Stall	SNPM	EPTYP	NAKSTS	Reserved	USBAEP	Reserved								MPSIZ							
	Reset value	0	0	0	0	0	0	0	0	0	0	0	0	0	0	0	1	0								0							
0xB20	OTG_FS_DOEP CTL1	EPENA	EPDIS	SODDFRM	SD0PID/SEVNFRM	SNAK	CNAK	Reserved				Stall	SNPM	EPTYP	NAKSTS	EONUM/DPID	USBAEP	Reserved				MPSIZ											
	Reset value	0	0	0	0	0	0	0	0	0	0	0	0	0	0	0	0	0	0	0	0	0	0	0	0	0	0	0	0	0	0	0	0
0xB40	OTG_FS_DOEP CTL2	EPENA	EPDIS	SODDFRM	SD0PID/SEVNFRM	SNAK	CNAK	Reserved				Stall	SNPM	EPTYP	NAKSTS	EONUM/DPID	USBAEP	Reserved				MPSIZ											
	Reset value	0	0	0	0	0	0	0	0	0	0	0	0	0	0	0	0	0	0	0	0	0	0	0	0	0	0	0	0	0	0	0	0
0xB60	OTG_FS_DOEP CTL3	EPENA	EPDIS	SODDFRM	SD0PID/SEVNFRM	SNAK	CNAK	Reserved				Stall	SNPM	EPTYP	NAKSTS	EONUM/DPID	USBAEP	Reserved				MPSIZ											
	Reset value	0	0	0	0	0	0	0	0	0	0	0	0	0	0	0	0	0	0	0	0	0	0	0	0	0	0	0	0	0	0	0	0
0x908	OTG_FS_DIEPI NT0	Reserved																				TXFE	INEPNE	Reserved									
	Reset value	0																				1	0	0									
0x928	OTG_FS_DIEPI NT1	Reserved																				TXFE	INEPNE	Reserved									
	Reset value	0																				1	0	0									
0x948	OTG_FS_DIEPI NT2	Reserved																				TXFE	INEPNE	Reserved									
	Reset value	0																				1	0	0									
0x968	OTG_FS_DIEPI NT3	Reserved																				TXFE	INEPNE	Reserved									
	Reset value	0																				1	0	0									
0xB08	OTG_FS_DOEP INT0	Reserved																				Reserved	B2BSTUP	Reserved									
	Reset value	0																				0	0	0									
0xB28	OTG_FS_DOEP INT1	Reserved																				Reserved	OTEPDIS	Reserved									
	Reset value	0																				0	0	0									



Table 202. OTG\_FS register map and reset values (continued)

Offset	Register	31	30	29	28	27	26	25	24	23	22	21	20	19	18	17	16	15	14	13	12	11	10	9	8	7	6	5	4	3	2	1	0							
0xB48	OTG_FS_DOEP_INT2	Reserved																								Reserved	B2BSTUP	Reserved	OTEPDIS	STUP	Reserved	EPDISD	XFFRC							
	Reset value																										0		0	0		0	0							
0xB68	OTG_FS_DOEP_INT3	Reserved																								Reserved	B2BSTUP	Reserved	OTEPDIS	STUP	Reserved	EPDISD	XFFRC							
	Reset value																										0		0	0		0	0							
0x910	OTG_FS_DIEP_TSI20	Reserved											PKTCNT	Reserved											XFRSIZ															
	Reset value												0	0												0	0	0	0	0	0									
0x930	OTG_FS_DIEP_TSI21	Reserved	MCNT	PKTCNT											XFRSIZ																									
	Reset value		0	0	0	0	0	0	0	0	0	0	0	0	0	0	0	0	0	0	0	0	0	0	0	0	0	0	0	0	0	0	0							
0x950	OTG_FS_DIEP_TSI22	Reserved	MCNT	PKTCNT											XFRSIZ																									
	Reset value		0	0	0	0	0	0	0	0	0	0	0	0	0	0	0	0	0	0	0	0	0	0	0	0	0	0	0	0	0	0	0							
0x970	OTG_FS_DIEP_TSI23	Reserved	MCNT	PKTCNT											XFRSIZ																									
	Reset value		0	0	0	0	0	0	0	0	0	0	0	0	0	0	0	0	0	0	0	0	0	0	0	0	0	0	0	0	0	0	0							
0xB10	OTG_FS_DOEP_TSI20	Reserved	STUPCNT	Reserved											PKTCNT	Reserved											XFRSIZ													
	Reset value		0	0												0												0	0	0	0	0								
0xB30	OTG_FS_DOEP_TSI21	Reserved	RXDPID/STUPCNT	PKTCNT											XFRSIZ																									
	Reset value		0	0	0	0	0	0	0	0	0	0	0	0	0	0	0	0	0	0	0	0	0	0	0	0	0	0	0	0	0	0	0							
0xB50	OTG_FS_DOEP_TSI22	Reserved	RXDPID/STUPCNT	PKTCNT											XFRSIZ																									
	Reset value		0	0	0	0	0	0	0	0	0	0	0	0	0	0	0	0	0	0	0	0	0	0	0	0	0	0	0	0	0	0	0							
0xB70	OTG_FS_DOEP_TSI23	Reserved	RXDPID/STUPCNT	PKTCNT											XFRSIZ																									
	Reset value		0	0	0	0	0	0	0	0	0	0	0	0	0	0	0	0	0	0	0	0	0	0	0	0	0	0	0	0	0	0	0							
0xE00	OTG_FS_PCG_CCTL	Reserved																								PHYSUSP	Reserved	GATECLK	STPCLK											
	Reset value																																							

Refer to [Table 1 on page 44](#) for the register boundary addresses.

## 27.16 OTG\_FS programming model

### 27.16.1 Core initialization

The application must perform the core initialization sequence. If the cable is connected during power-up, the current mode of operation bit in the OTG\_FS\_GINTSTS (CMOD bit in OTG\_FS\_GINTSTS) reflects the mode. The OTG\_FS controller enters Host mode when an “A” plug is connected or Device mode when a “B” plug is connected.

This section explains the initialization of the OTG\_FS controller after power-on. The application must follow the initialization sequence irrespective of Host or Device mode operation. All core global registers are initialized according to the core's configuration:

1. Program the following fields in the OTG\_FS\_GAHBCFG register:
  - Global interrupt mask bit GINTMSK = 1
  - RxFIFO non-empty (RXFLVL bit in OTG\_FS\_GINTSTS)
  - Periodic TxFIFO empty level
2. Program the following fields in the OTG\_FS\_GUSBCFG register:
  - HNP capable bit
  - SRP capable bit
  - FS timeout calibration field
  - USB turnaround time field
3. The software must unmask the following bits in the OTG\_FS\_GINTMSK register:
  - OTG interrupt mask
  - Mode mismatch interrupt mask
4. The software can read the CMOD bit in OTG\_FS\_GINTSTS to determine whether the OTG\_FS controller is operating in Host or Device mode.

### 27.16.2 Host initialization

To initialize the core as host, the application must perform the following steps:

1. Program the HPRTINT in the OTG\_FS\_GINTMSK register to unmask
2. Program the OTG\_FS\_HCFG register to select full-speed host
3. Program the PPWR bit in OTG\_FS\_HPRT to 1. This drives  $V_{BUS}$  on the USB.
4. Wait for the PCDET interrupt in OTG\_FS\_HPRT0. This indicates that a device is connecting to the port.
5. Program the PRST bit in OTG\_FS\_HPRT to 1. This starts the reset process.
6. Wait at least 10 ms for the reset process to complete.
7. Program the PRST bit in OTG\_FS\_HPRT to 0.
8. Wait for the PENCHNG interrupt in OTG\_FS\_HPRT.
9. Read the PSPD bit in OTG\_FS\_HPRT to get the enumerated speed.
10. Program the HFIR register with a value corresponding to the selected PHY clock 1
11. Program the FSLSPCS field in the OTG\_FS\_HCFG register following the speed of the device detected in step 9. If FSLSPCS has been changed a port reset must be performed.
12. Program the OTG\_FS\_GRXFSIZ register to select the size of the receive FIFO.
13. Program the OTG\_FS\_HNPTXFSIZ register to select the size and the start address of the Non-periodic transmit FIFO for non-periodic transactions.
14. Program the OTG\_FS\_HPTXFSIZ register to select the size and start address of the periodic transmit FIFO for periodic transactions.

To communicate with devices, the system software must initialize and enable at least one channel.

### 27.16.3 Device initialization

The application must perform the following steps to initialize the core as a device on power-up or after a mode change from Host to Device.

1. Program the following fields in the OTG\_FS\_DCFG register:
  - Device speed
  - Non-zero-length status OUT handshake
2. Program the OTG\_FS\_GINTMSK register to unmask the following interrupts:
  - USB reset
  - Enumeration done
  - Early suspend
  - USB suspend
  - SOF
3. Program the VBUSSEN bit in the OTG\_FS\_GCCFG register to enable  $V_{BUS}$  sensing in “B” device mode and supply the 5 volts across the pull-up resistor on the DP line.
4. Wait for the USBRST interrupt in OTG\_FS\_GINTSTS. It indicates that a reset has been detected on the USB that lasts for about 10 ms on receiving this interrupt.

Wait for the ENUMDNE interrupt in OTG\_FS\_GINTSTS. This interrupt indicates the end of reset on the USB. On receiving this interrupt, the application must read the OTG\_FS\_DSTS

register to determine the enumeration speed and perform the steps listed in [Endpoint initialization on enumeration completion on page 886](#).

At this point, the device is ready to accept SOF packets and perform control transfers on control endpoint 0.

## 27.16.4 Host programming model

### Channel initialization

The application must initialize one or more channels before it can communicate with connected devices. To initialize and enable a channel, the application must perform the following steps:

1. Program the OTG\_FS\_GINTMSK register to unmask the following:
2. Channel interrupt
  - Non-periodic transmit FIFO empty for OUT transactions (applicable when operating in pipelined transaction-level with the packet count field programmed with more than one).
  - Non-periodic transmit FIFO half-empty for OUT transactions (applicable when operating in pipelined transaction-level with the packet count field programmed with more than one).
3. Program the OTG\_FS\_HAINTMSK register to unmask the selected channels' interrupts.
4. Program the OTG\_FS\_HCINTMSK register to unmask the transaction-related interrupts of interest given in the host channel interrupt register.
5. Program the selected channel's OTG\_FS\_HCTSIZx register with the total transfer size, in bytes, and the expected number of packets, including short packets. The application must program the PID field with the initial data PID (to be used on the first OUT transaction or to be expected from the first IN transaction).
6. Program the OTG\_FS\_HCCHARx register of the selected channel with the device's endpoint characteristics, such as type, speed, direction, and so forth. (The channel can be enabled by setting the channel enable bit to 1 only when the application is ready to transmit or receive any packet).

### Halting a channel

The application can disable any channel by programming the OTG\_FS\_HCCHARx register with the CHDIS and CHENA bits set to 1. This enables the OTG\_FS host to flush the posted requests (if any) and generates a channel halted interrupt. The application must wait for the CHH interrupt in OTG\_FS\_HCINTx before reallocating the channel for other transactions. The OTG\_FS host does not interrupt the transaction that has already been started on the USB.

Before disabling a channel, the application must ensure that there is at least one free space available in the non-periodic request queue (when disabling a non-periodic channel) or the periodic request queue (when disabling a periodic channel). The application can simply flush the posted requests when the Request queue is full (before disabling the channel), by programming the OTG\_FS\_HCCHARx register with the CHDIS bit set to 1, and the CHENA bit cleared to 0.

The application is expected to disable a channel on any of the following conditions:

1. When an STALL, TXERR, BBERR or DTERR interrupt in OTG\_FS\_HCINTx is received for an IN or OUT channel. The application must be able to receive other interrupts (DTERR, Nak, Data, TXERR) for the same channel before receiving the halt.
2. When a DISCINT (Disconnect Device) interrupt in OTG\_FS\_GINTSTS is received. (The application is expected to disable all enabled channels).
3. When the application aborts a transfer before normal completion.

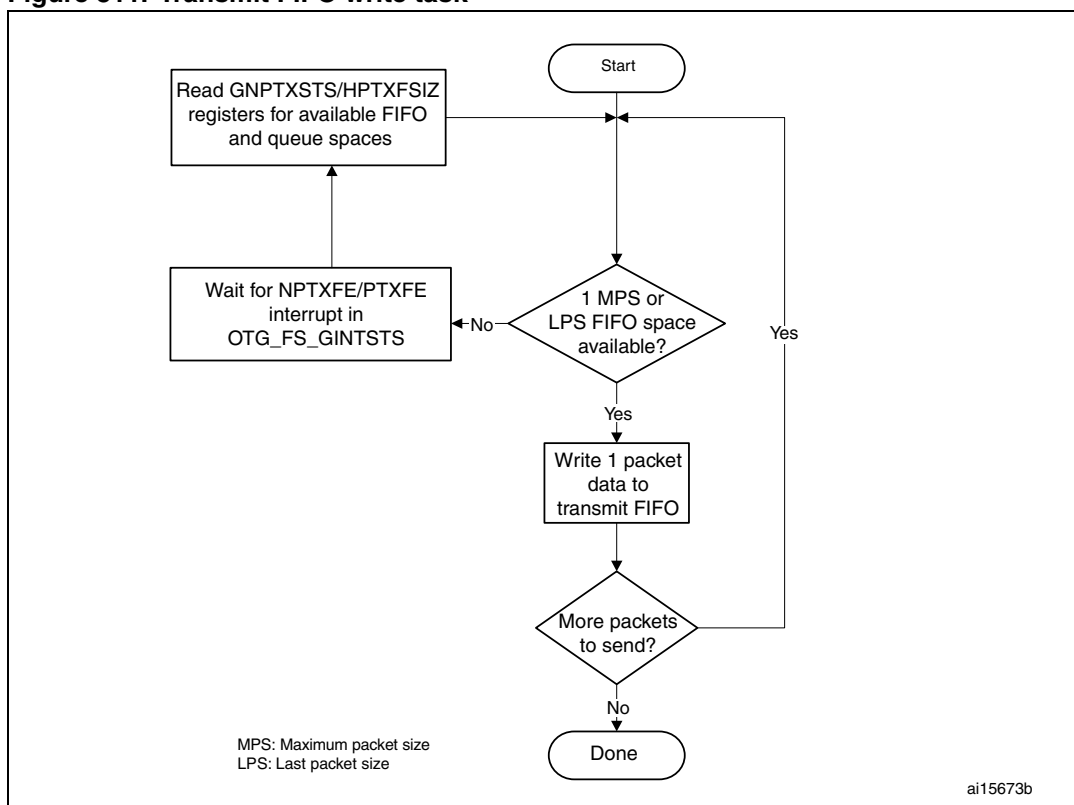
**Operational model**

The application must initialize a channel before communicating to the connected device. This section explains the sequence of operation to be performed for different types of USB transactions.

● **Writing the transmit FIFO**

The OTG\_FS host automatically writes an entry (OUT request) to the periodic/non-periodic request queue, along with the last Word write of a packet. The application must ensure that at least one free space is available in the periodic/non-periodic request queue before starting to write to the transmit FIFO. The application must always write to the transmit FIFO in Words. If the packet size is non-Word aligned, the application must use padding. The OTG\_FS host determines the actual packet size based on the programmed maximum packet size and transfer size.

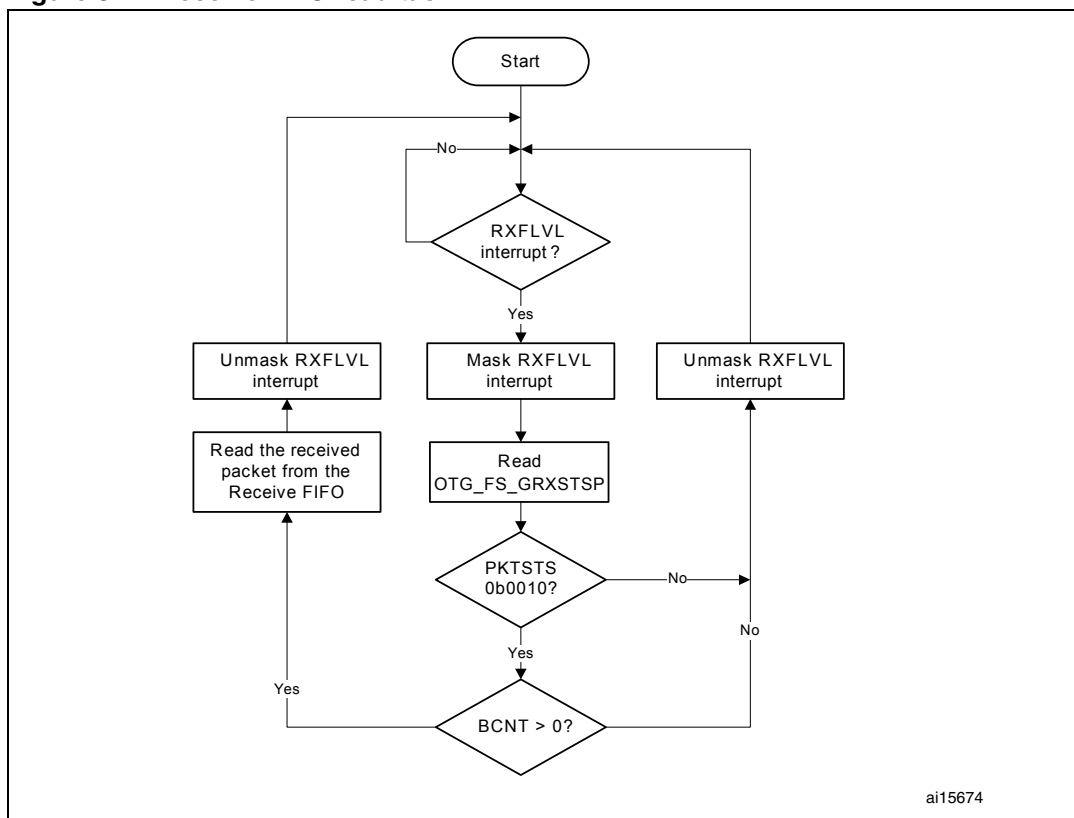
**Figure 311. Transmit FIFO write task**



● **Reading the receive FIFO**

The application must ignore all packet statuses other than IN data packet (bx0010).

Figure 312. Receive FIFO read task



● **Bulk and control OUT/SETUP transactions**

A typical bulk or control OUT/SETUP pipelined transaction-level operation is shown in [Figure 313](#). See channel 1 (ch\_1). Two bulk OUT packets are transmitted. A control SETUP transaction operates in the same way but has only one packet. The assumptions are:

- The application is attempting to send two maximum-packet-size packets (transfer size = 1,024 bytes).
- The non-periodic transmit FIFO can hold two packets (128 bytes for FS).
- The non-periodic request queue depth = 4.

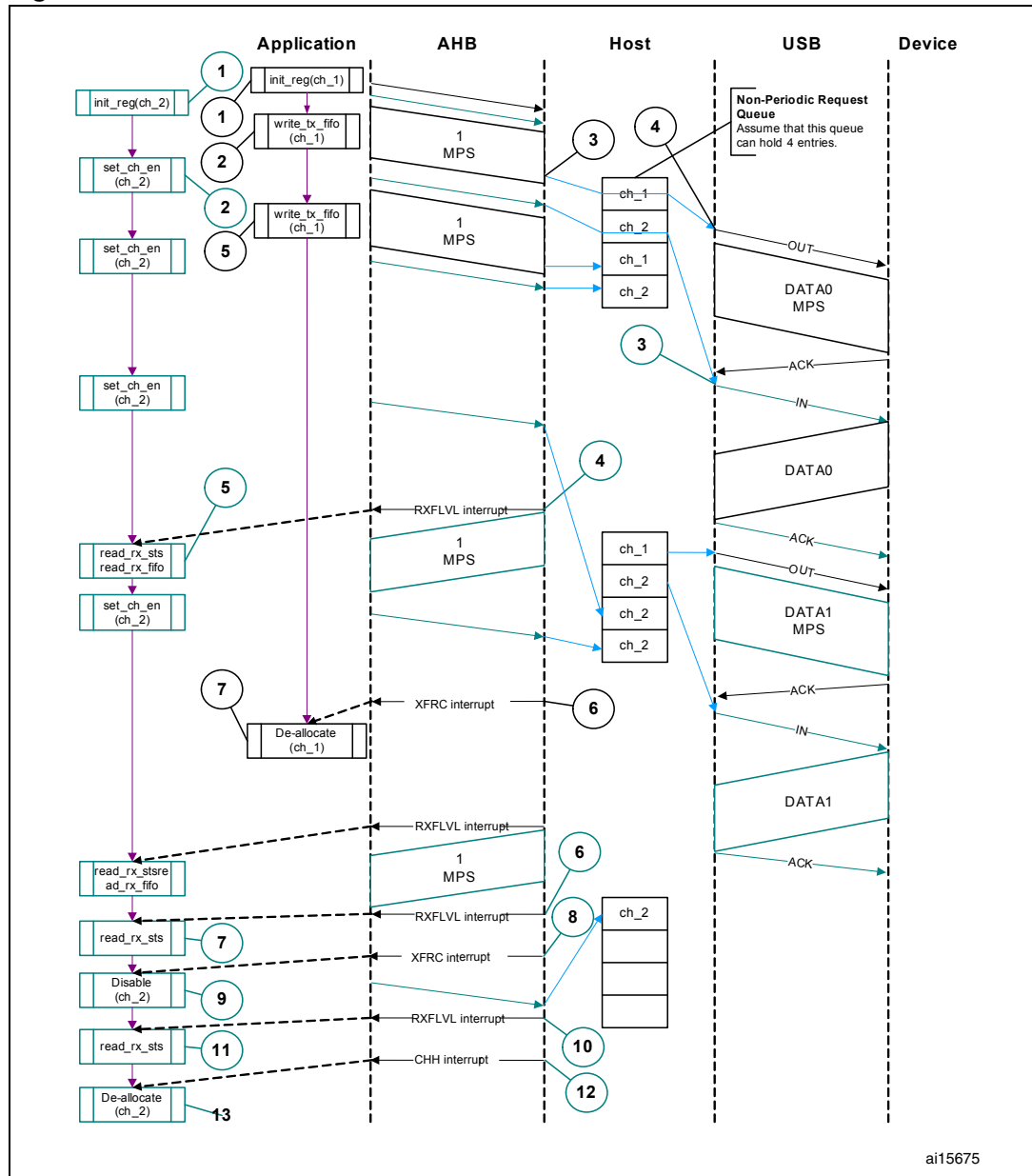
● **Normal bulk and control OUT/SETUP operations**

The sequence of operations in (channel 1) is as follows:

- a) Initialize channel 1
- b) Write the first packet for channel 1
- c) Along with the last Word write, the core writes an entry to the non-periodic request queue
- d) As soon as the non-periodic queue becomes non-empty, the core attempts to send an OUT token in the current frame
- e) Write the second (last) packet for channel 1
- f) The core generates the XFRC interrupt as soon as the last transaction is completed successfully
- g) In response to the XFRC interrupt, de-allocate the channel for other transfers
- h) Handling non-ACK responses



Figure 313. Normal bulk/control OUT/SETUP and bulk/control IN transactions



ai15675

The channel-specific interrupt service routine for bulk and control OUT/SETUP transactions is shown in the following code samples.

- **Interrupt service routine for bulk/control OUT/SETUP and bulk/control IN transactions**

- a) Bulk/Control OUT/SETUP

```

Unmask (NAK/TXERR/STALL/XFRC)
if (XFRC)
{
  Reset Error Count
  Mask ACK
  De-allocate Channel

```

```

    }
else if (STALL)
{
    Transfer Done = 1
    Unmask CHH
    Disable Channel
}
else if (NAK or TXERR )
{
    Rewind Buffer Pointers
    Unmask CHH
    Disable Channel
    if (TXERR)
    {
        Increment Error Count
        Unmask ACK
    }
    else
    {
        Reset Error Count
    }
}
else if (CHH)
{
    Mask CHH
    if (Transfer Done or (Error_count == 3))
    {
        De-allocate Channel
    }
    else
    {
        Re-initialize Channel
    }
}
else if (ACK)
{
    Reset Error Count
    Mask ACK
}

```

The application is expected to write the data packets into the transmit FIFO as and when the space is available in the transmit FIFO and the Request queue. The application can make use of the NPTXFE interrupt in OTG\_FS\_GINTSTS to find the transmit FIFO space.

b) Bulk/Control IN

```

Unmask (TXERR/XFRC/BBERR/STALL/DTERR)
if (XFRC)
{
    Reset Error Count
    Unmask CHH
    Disable Channel
    Reset Error Count
}

```

```

    Mask ACK
  }
else if (TXERR or BBERR or STALL)
{
  Unmask CHH
  Disable Channel
  if (TXERR)
  {
    Increment Error Count
    Unmask ACK
  }
}
else if (CHH)
{
  Mask CHH
  if (Transfer Done or (Error_count == 3))
  {
    De-allocate Channel
  }
  else
  {
    Re-initialize Channel
  }
}
else if (ACK)
{
  Reset Error Count
  Mask ACK
}
else if (DTERR)
{
  Reset Error Count
}

```

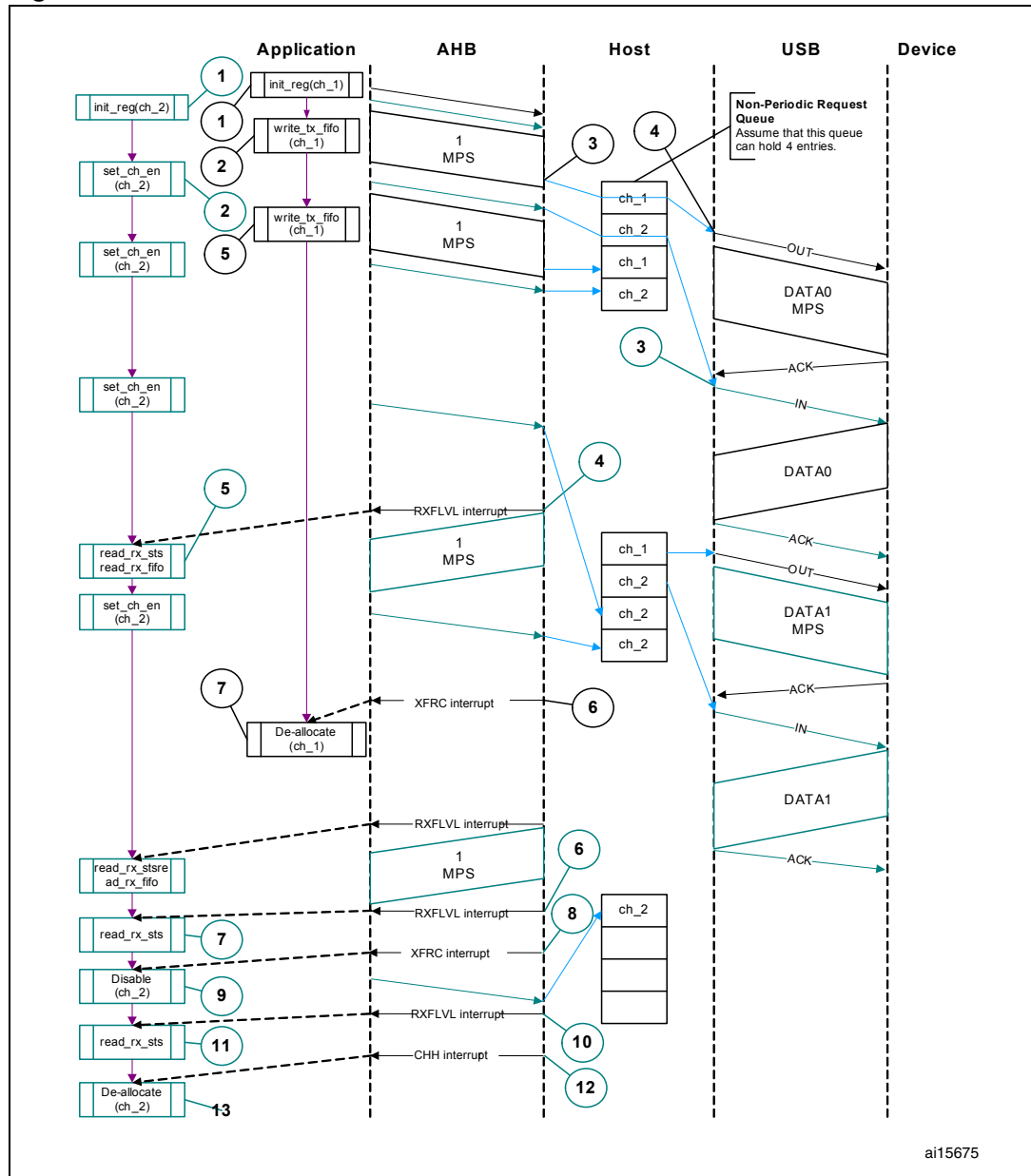
The application is expected to write the requests as and when the Request queue space is available and until the XFRC interrupt is received.

- **Bulk and control IN transactions**

A typical bulk or control IN pipelined transaction-level operation is shown in [Figure 314](#). See channel 2 (ch\_2). The assumptions are:

- The application is attempting to receive two maximum-packet-size packets (transfer size = 1 024 bytes).
- The receive FIFO can contain at least one maximum-packet-size packet and two status Words per packet (72 bytes for FS).
- The non-periodic request queue depth = 4.

Figure 314. Bulk/control IN transactions



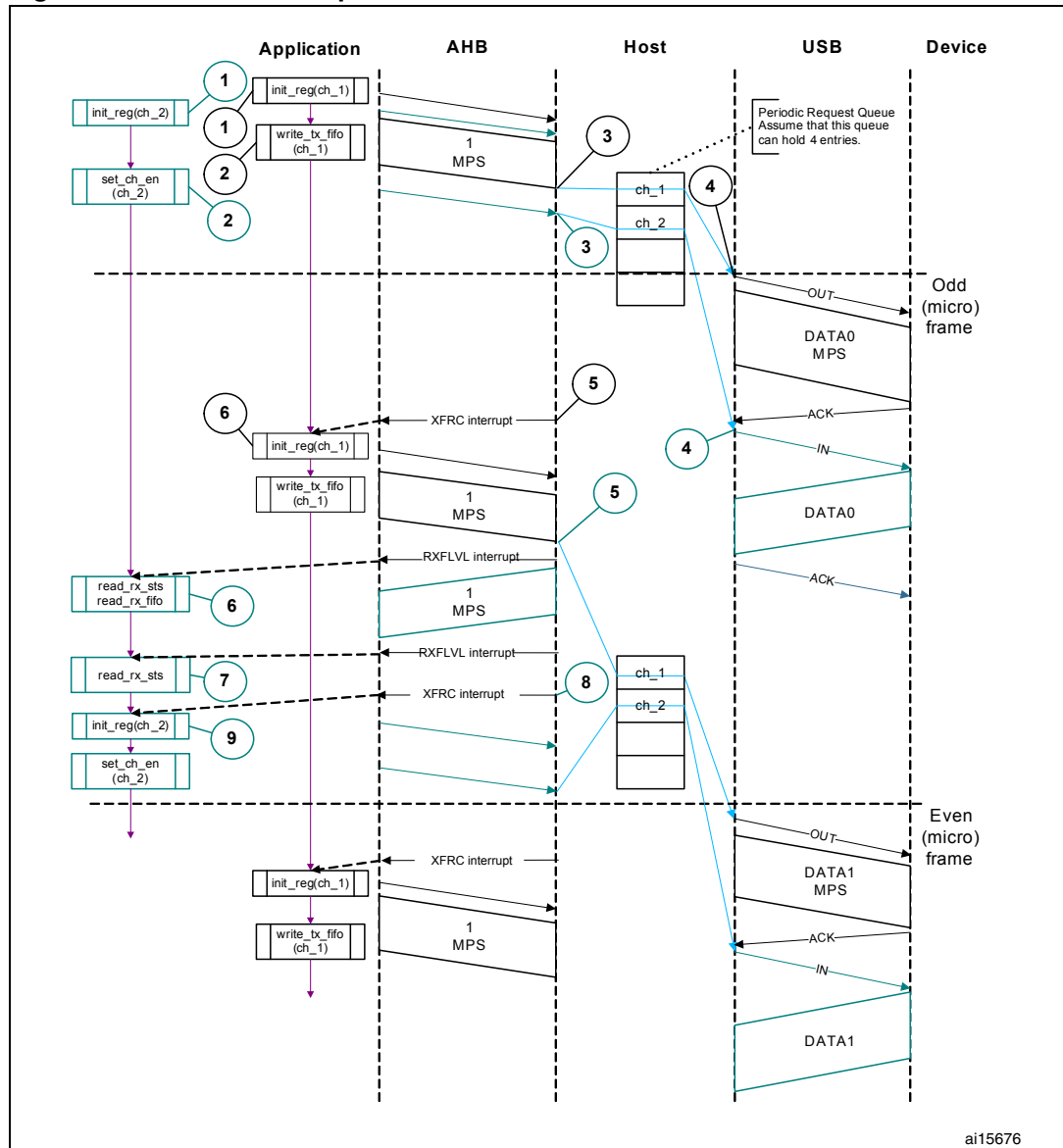
ai15675

The sequence of operations is as follows:

- a) Initialize channel 2.
- b) Set the CHENA bit in HCCHAR2 to write an IN request to the non-periodic request queue.
- c) The core attempts to send an IN token after completing the current OUT transaction.
- d) The core generates an RXFLVL interrupt as soon as the received packet is written to the receive FIFO.
- e) In response to the RXFLVL interrupt, mask the RXFLVL interrupt and read the received packet status to determine the number of bytes received, then read the receive FIFO accordingly. Following this, unmask the RXFLVL interrupt.

- f) The core generates the RXFLVL interrupt for the transfer completion status entry in the receive FIFO.
  - g) The application must read and ignore the receive packet status when the receive packet status is not an IN data packet (PKTSTS in GRXSTSR  $\neq$  0b0010).
  - h) The core generates the XFRC interrupt as soon as the receive packet status is read.
  - i) In response to the XFRC interrupt, disable the channel and stop writing the OTG\_FS\_HCCHAR2 register for further requests. The core writes a channel disable request to the non-periodic request queue as soon as the OTG\_FS\_HCCHAR2 register is written.
  - j) The core generates the RXFLVL interrupt as soon as the halt status is written to the receive FIFO.
  - k) Read and ignore the receive packet status.
  - l) The core generates a CHH interrupt as soon as the halt status is popped from the receive FIFO.
  - m) In response to the CHH interrupt, de-allocate the channel for other transfers.
  - n) Handling non-ACK responses
- **Control transactions**  
Setup, Data, and Status stages of a control transfer must be performed as three separate transfers. Setup-, Data- or Status-stage OUT transactions are performed similarly to the bulk OUT transactions explained previously. Data- or Status-stage IN transactions are performed similarly to the bulk IN transactions explained previously. For all three stages, the application is expected to set the EPTYP field in OTG\_FS\_HCCHAR1 to Control. During the Setup stage, the application is expected to set the PID field in OTG\_FS\_HCTSIZ1 to SETUP.
  - **Interrupt OUT transactions**  
A typical interrupt OUT operation is shown in [Figure 315](#). The assumptions are:
    - The application is attempting to send one packet in every frame (up to 1 maximum packet size), starting with the odd frame (transfer size = 1 024 bytes)
    - The periodic transmit FIFO can hold one packet (1 KB)
    - Periodic request queue depth = 4
 The sequence of operations is as follows:
    - a) Initialize and enable channel 1. The application must set the ODDFRM bit in OTG\_FS\_HCCHAR1.
    - b) Write the first packet for channel 1.
    - c) Along with the last Word write of each packet, the OTG\_FS host writes an entry to the periodic request queue.
    - d) The OTG\_FS host attempts to send an OUT token in the next (odd) frame.
    - e) The OTG\_FS host generates an XFRC interrupt as soon as the last packet is transmitted successfully.
    - f) In response to the XFRC interrupt, reinitialize the channel for the next transfer.

Figure 315. Normal interrupt OUT/IN transactions



● Interrupt service routine for interrupt OUT/IN transactions

a) Interrupt OUT

```

Unmask (NAK/TXERR/STALL/XFRC/FRMOR)
if (XFRC)
{
    Reset Error Count
    Mask ACK
    De-allocate Channel
}
else
    if (STALL or FRMOR)
    {
        Mask ACK
        Unmask CHH
    }
    
```

```

Disable Channel
if (STALL)
{
    Transfer Done = 1
}
}
else
if (NAK or TXERR)
{
    Rewind Buffer Pointers
    Reset Error Count
    Mask ACK
    Unmask CHH
    Disable Channel
}
else
if (CHH)
{
    Mask CHH
    if (Transfer Done or (Error_count == 3))
    {
        De-allocate Channel
    }
    else
    {
        Re-initialize Channel (in next b_interval - 1 Frame)
    }
}
else
if (ACK)
{
    Reset Error Count
    Mask ACK
}

```

The application uses the NPTXFE interrupt in OTG\_FS\_GINTSTS to find the transmit FIFO space.

#### b) Interrupt IN

```

Unmask (NAK/TXERR/XFRC/BBERR/STALL/FRMOR/DTERR)
if (XFRC)
{
    Reset Error Count
    Mask ACK
    if (OTG_FS_HCTSIZx.PKTCNT == 0)
    {
        De-allocate Channel
    }
}
else
{
    Transfer Done = 1
    Unmask CHH
    Disable Channel
}

```

```
    }
else
    if (STALL or FRMOR or NAK or DTERR or BBERR)
    {
        Mask ACK
        Unmask CHH
        Disable Channel
        if (STALL or BBERR)
        {
            Reset Error Count
            Transfer Done = 1
        }
        else
            if (!FRMOR)
            {
                Reset Error Count
            }
    }
else
    if (TXERR)
    {
        Increment Error Count
        Unmask ACK
        Unmask CHH
        Disable Channel
    }
else
    if (CHH)
    {
        Mask CHH
        if (Transfer Done or (Error_count == 3))
        {
            De-allocate Channel
        }
        else
            Re-initialize Channel (in next b_interval - 1 /Frame)
    }
    }
else
    if (ACK)
    {
        Reset Error Count
        Mask ACK
    }
}
```



- **Interrupt IN transactions**

The assumptions are:

- The application is attempting to receive one packet (up to 1 maximum packet size) in every frame, starting with odd (transfer size = 1 024 bytes).
- The receive FIFO can hold at least one maximum-packet-size packet and two status Words per packet (1 031 bytes).
- Periodic request queue depth = 4.

- **Normal interrupt IN operation**

The sequence of operations is as follows:

- a) Initialize channel 2. The application must set the ODDFRM bit in OTG\_FS\_HCCHAR2.
- b) Set the CHENA bit in OTG\_FS\_HCCHAR2 to write an IN request to the periodic request queue.
- c) The OTG\_FS host writes an IN request to the periodic request queue for each OTG\_FS\_HCCHAR2 register write with the CHENA bit set.
- d) The OTG\_FS host attempts to send an IN token in the next (odd) frame.
- e) As soon as the IN packet is received and written to the receive FIFO, the OTG\_FS host generates an RXFLVL interrupt.
- f) In response to the RXFLVL interrupt, read the received packet status to determine the number of bytes received, then read the receive FIFO accordingly. The application must mask the RXFLVL interrupt before reading the receive FIFO, and unmask after reading the entire packet.
- g) The core generates the RXFLVL interrupt for the transfer completion status entry in the receive FIFO. The application must read and ignore the receive packet status when the receive packet status is not an IN data packet (PKTSTS in GRXSTSR ≠ 0b0010).
- h) The core generates an XFRC interrupt as soon as the receive packet status is read.
- i) In response to the XFRC interrupt, read the PKTCNT field in OTG\_FS\_HCTSIZ2. If the PKTCNT bit in OTG\_FS\_HCTSIZ2 is not equal to 0, disable the channel before re-initializing the channel for the next transfer, if any). If PKTCNT bit in OTG\_FS\_HCTSIZ2 = 0, reinitialize the channel for the next transfer. This time, the application must reset the ODDFRM bit in OTG\_FS\_HCCHAR2.

- **Isochronous OUT transactions**

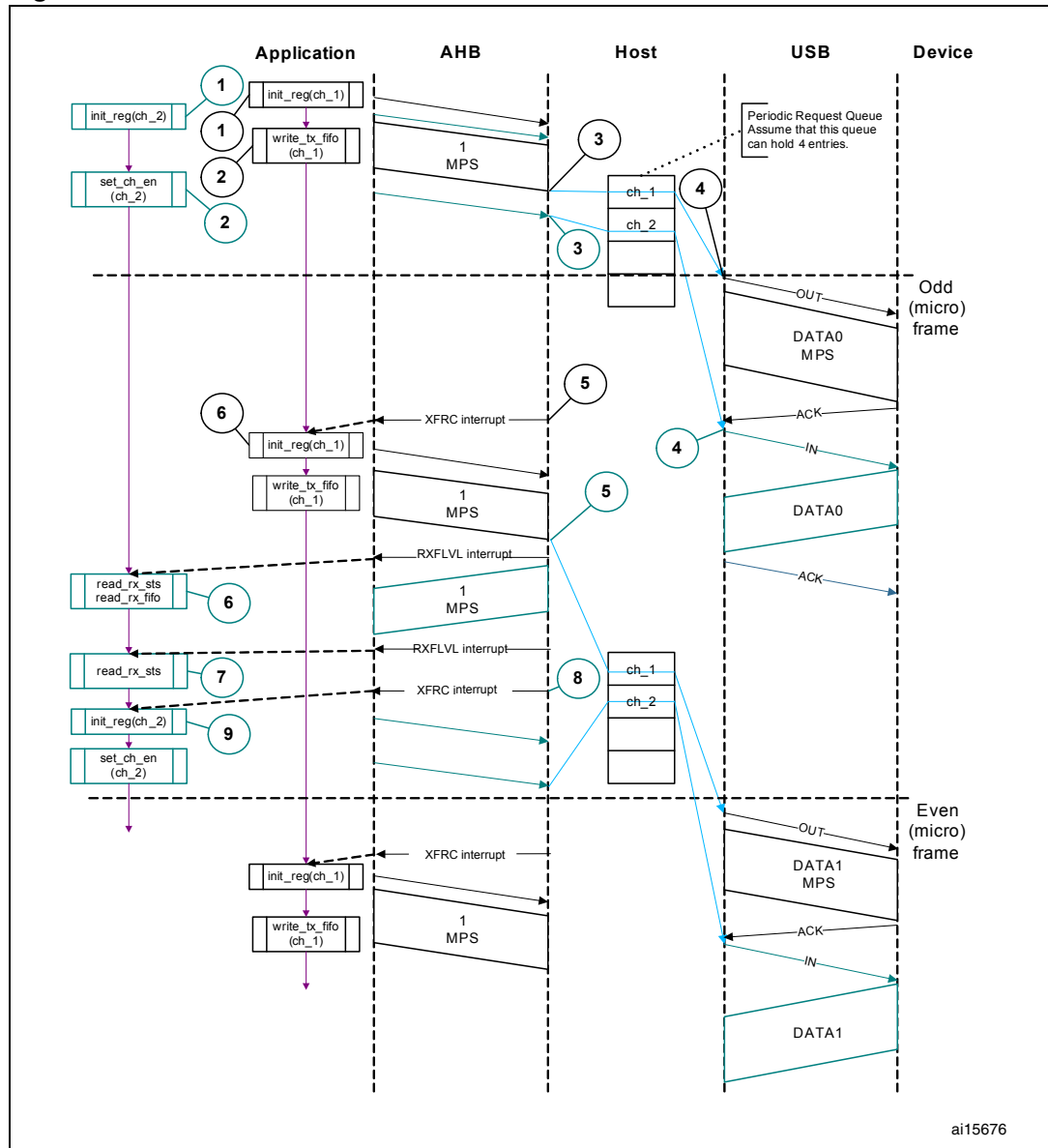
A typical isochronous OUT operation is shown in [Figure 316](#). The assumptions are:

- The application is attempting to send one packet every frame (up to 1 maximum packet size), starting with an odd frame. (transfer size = 1 024 bytes).
- The periodic transmit FIFO can hold one packet (1 KB).
- Periodic request queue depth = 4.

The sequence of operations is as follows:

- a) Initialize and enable channel 1. The application must set the ODDFRM bit in OTG\_FS\_HCCHAR1.
- b) Write the first packet for channel 1.
- c) Along with the last Word write of each packet, the OTG\_FS host writes an entry to the periodic request queue.
- d) The OTG\_FS host attempts to send the OUT token in the next frame (odd).
- e) The OTG\_FS host generates the XFRC interrupt as soon as the last packet is transmitted successfully.
- f) In response to the XFRC interrupt, reinitialize the channel for the next transfer.
- g) Handling non-ACK responses

Figure 316. Normal isochronous OUT/IN transactions



● **Interrupt service routine for isochronous OUT/IN transactions**

Code sample: Isochronous OUT

```

Unmask (FRMOR/XFRC)
if (XFRC)
{
    De-allocate Channel
}
else
    if (FRMOR)
    {
        Unmask CHH
        Disable Channel
    }
else
    
```

```
if (CHH)
{
Mask CHH
De-allocate Channel
}

Code sample: Isochronous IN
Unmask (TXERR/XFRC/FRMOR/BBERR)
if (XFRC or FRMOR)
{
if (XFRC and (OTG_FS_HCTSIZx.PKTCNT == 0))
{
Reset Error Count
De-allocate Channel
}
else
{
Unmask CHH
Disable Channel
}
}
else
if (TXERR or BBERR)
{
Increment Error Count
Unmask CHH
Disable Channel
}
else
if (CHH)
{
Mask CHH
if (Transfer Done or (Error_count == 3))
{
De-allocate Channel
}
else
{
Re-initialize Channel
}
}
}
```

- **Isochronous IN transactions**

The assumptions are:

- The application is attempting to receive one packet (up to 1 maximum packet size) in every frame starting with the next odd frame (transfer size = 1 024 bytes).
- The receive FIFO can hold at least one maximum-packet-size packet and two status Word per packet (1 031 bytes).
- Periodic request queue depth = 4.

The sequence of operations is as follows:

- a) Initialize channel 2. The application must set the ODDFRM bit in OTG\_FS\_HCCHAR2.
- b) Set the CHENA bit in OTG\_FS\_HCCHAR2 to write an IN request to the periodic request queue.
- c) The OTG\_FS host writes an IN request to the periodic request queue for each OTG\_FS\_HCCHAR2 register write with the CHENA bit set.
- d) The OTG\_FS host attempts to send an IN token in the next odd frame.
- e) As soon as the IN packet is received and written to the receive FIFO, the OTG\_FS host generates an RXFLVL interrupt.
- f) In response to the RXFLVL interrupt, read the received packet status to determine the number of bytes received, then read the receive FIFO accordingly. The application must mask the RXFLVL interrupt before reading the receive FIFO, and unmask it after reading the entire packet.
- g) The core generates an RXFLVL interrupt for the transfer completion status entry in the receive FIFO. This time, the application must read and ignore the receive packet status when the receive packet status is not an IN data packet (PKTSTS bit in OTG\_FS\_GRXSTSR  $\neq$  0b0010).
- h) The core generates an XFRC interrupt as soon as the receive packet status is read.
- i) In response to the XFRC interrupt, read the PKTCNT field in OTG\_FS\_HCTSIZ2. If  $PKTCNT \neq 0$  in OTG\_FS\_HCTSIZ2, disable the channel before re-initializing the channel for the next transfer, if any. If  $PKTCNT = 0$  in OTG\_FS\_HCTSIZ2, reinitialize the channel for the next transfer. This time, the application must reset the ODDFRM bit in OTG\_FS\_HCCHAR2.

- **Selecting the queue depth**

Choose the periodic and non-periodic request queue depths carefully to match the number of periodic/non-periodic endpoints accessed.

The non-periodic request queue depth affects the performance of non-periodic transfers. The deeper the queue (along with sufficient FIFO size), the more often the core is able to pipeline non-periodic transfers. If the queue size is small, the core is able to put in new requests only when the queue space is freed up.

The core's periodic request queue depth is critical to perform periodic transfers as scheduled. Select the periodic queue depth, based on the number of periodic transfers scheduled in a microframe. If the periodic request queue depth is smaller than the periodic transfers scheduled in a microframe, a frame overrun condition occurs.

- **Handling babble conditions**

OTG\_FS controller handles two cases of babble: packet babble and port babble. Packet babble occurs if the device sends more data than the maximum packet size for

the channel. Port babble occurs if the core continues to receive data from the device at EOF2 (the end of frame 2, which is very close to SOF).

When OTG\_FS controller detects a packet babble, it stops writing data into the Rx buffer and waits for the end of packet (EOP). When it detects an EOP, it flushes already written data in the Rx buffer and generates a Babble interrupt to the application.

When OTG\_FS controller detects a port babble, it flushes the RxFIFO and disables the port. The core then generates a Port disabled interrupt (HPRTINT in OTG\_FS\_GINTSTS, PENCHNG in OTG\_FS\_HPRT). On receiving this interrupt, the application must determine that this is not due to an overcurrent condition (another cause of the Port Disabled interrupt) by checking POCA in OTG\_FS\_HPRT, then perform a soft reset. The core does not send any more tokens after it has detected a port babble condition.

## 27.16.5 Device programming model

### Endpoint initialization on USB reset

1. Set the NAK bit for all OUT endpoints
  - SNAK = 1 in OTG\_FS\_DOEPCTLx (for all OUT endpoints)
2. Unmask the following interrupt bits
  - INEP0 = 1 in OTG\_FS\_DAINMSK (control 0 IN endpoint)
  - OUTEP0 = 1 in OTG\_FS\_DAINMSK (control 0 OUT endpoint)
  - STUP = 1 in DOEPMSK
  - XFRC = 1 in DOEPMSK
  - XFRC = 1 in DIEPMSK
  - TOC = 1 in DIEPMSK
3. Set up the Data FIFO RAM for each of the FIFOs
  - Program the OTG\_FS\_GRXFSIZ register, to be able to receive control OUT data and setup data. If thresholding is not enabled, at a minimum, this must be equal to 1 max packet size of control endpoint 0 + 2 Words (for the status of the control OUT data packet) + 10 Words (for setup packets).
  - Program the OTG\_FS\_TX0FSIZ register (depending on the FIFO number chosen) to be able to transmit control IN data. At a minimum, this must be equal to 1 max packet size of control endpoint 0.
4. Program the following fields in the endpoint-specific registers for control OUT endpoint 0 to receive a SETUP packet
  - STUPCNT = 3 in OTG\_FS\_DOEPTSIZ0 (to receive up to 3 back-to-back SETUP packets)

At this point, all initialization required to receive SETUP packets is done.

### Endpoint initialization on enumeration completion

1. On the Enumeration Done interrupt (ENUMDNE in OTG\_FS\_GINTSTS), read the OTG\_FS\_DSTS register to determine the enumeration speed.
2. Program the MPSIZ field in OTG\_FS\_DIEPCTL0 to set the maximum packet size. This step configures control endpoint 0. The maximum packet size for a control endpoint depends on the enumeration speed.

At this point, the device is ready to receive SOF packets and is configured to perform control transfers on control endpoint 0.

### Endpoint initialization on SetAddress command

This section describes what the application must do when it receives a SetAddress command in a SETUP packet.

1. Program the OTG\_FS\_DCFG register with the device address received in the SetAddress command
1. Program the core to send out a status IN packet

### Endpoint initialization on SetConfiguration/SetInterface command

This section describes what the application must do when it receives a SetConfiguration or SetInterface command in a SETUP packet.

1. When a SetConfiguration command is received, the application must program the endpoint registers to configure them with the characteristics of the valid endpoints in the new configuration.
2. When a SetInterface command is received, the application must program the endpoint registers of the endpoints affected by this command.
3. Some endpoints that were active in the prior configuration or alternate setting are not valid in the new configuration or alternate setting. These invalid endpoints must be deactivated.
4. Unmask the interrupt for each active endpoint and mask the interrupts for all inactive endpoints in the OTG\_FS\_DAINMSK register.
5. Set up the Data FIFO RAM for each FIFO.
6. After all required endpoints are configured; the application must program the core to send a status IN packet.

At this point, the device core is configured to receive and transmit any type of data packet.

### Endpoint activation

This section describes the steps required to activate a device endpoint or to configure an existing device endpoint to a new type.

1. Program the characteristics of the required endpoint into the following fields of the OTG\_FS\_DIEPCTLx register (for IN or bidirectional endpoints) or the OTG\_FS\_DOEPCTLx register (for OUT or bidirectional endpoints).
  - Maximum packet size
  - USB active endpoint = 1
  - Endpoint start data toggle (for interrupt and bulk endpoints)
  - Endpoint type
  - TxFIFO number
2. Once the endpoint is activated, the core starts decoding the tokens addressed to that endpoint and sends out a valid handshake for each valid token received for the endpoint.

### Endpoint deactivation

This section describes the steps required to deactivate an existing endpoint.

1. In the endpoint to be deactivated, clear the USB active endpoint bit in the OTG\_FS\_DIEPCTLx register (for IN or bidirectional endpoints) or the OTG\_FS\_DOEPCTLx register (for OUT or bidirectional endpoints).
2. Once the endpoint is deactivated, the core ignores tokens addressed to that endpoint, which results in a timeout on the USB.

*Note:* 1 The application must meet the following conditions to set up the device core to handle traffic: NPTXFEM and RXFLVLM in the OTG\_FS\_GINTMSK register must be cleared.

## 27.16.6 Operational model

### SETUP and OUT data transfers

This section describes the internal data flow and application-level operations during data OUT transfers and SETUP transactions.

#### ● Packet read

This section describes how to read packets (OUT data and SETUP packets) from the receive FIFO.

1. On catching an RXFLVL interrupt (OTG\_FS\_GINTSTS register), the application must read the Receive status pop register (OTG\_FS\_GRXSTSP).
2. The application can mask the RXFLVL interrupt (in OTG\_FS\_GINTSTS) by writing to RXFLVL = 0 (in OTG\_FS\_GINTMSK), until it has read the packet from the receive FIFO.
3. If the received packet's byte count is not 0, the byte count amount of data is popped from the receive Data FIFO and stored in memory. If the received packet byte count is 0, no data is popped from the receive data FIFO.
4. The receive FIFO's packet status readout indicates one of the following:
  - a) Global OUT NAK pattern:  
PKTSTS = Global OUT NAK, BCNT = 0x000, EPNUM = Don't Care (0x0), DPID = Don't Care (0b00).  
These data indicate that the global OUT NAK bit has taken effect.
  - b) SETUP packet pattern:  
PKTSTS = SETUP, BCNT = 0x008, EPNUM = Control EP Num, DPID = D0.  
These data indicate that a SETUP packet for the specified endpoint is now available for reading from the receive FIFO.
  - c) Setup stage done pattern:  
PKTSTS = Setup Stage Done, BCNT = 0x0, EPNUM = Control EP Num, DPID = Don't Care (0b00).  
These data indicate that the Setup stage for the specified endpoint has completed and the Data stage has started. After this entry is popped from the receive FIFO, the core asserts a Setup interrupt on the specified control OUT endpoint.
  - d) Data OUT packet pattern:  
PKTSTS = DataOUT, BCNT = size of the received data OUT packet ( $0 \leq BCNT \leq 1024$ ), EPNUM = EPNUM on which the packet was received, DPID = Actual Data PID.
  - e) Data transfer completed pattern:  
PKTSTS = Data OUT Transfer Done, BCNT = 0x0, EPNUM = OUT EP Num on which the data transfer is complete, DPID = Don't Care (0b00).  
These data indicate that an OUT data transfer for the specified OUT endpoint has

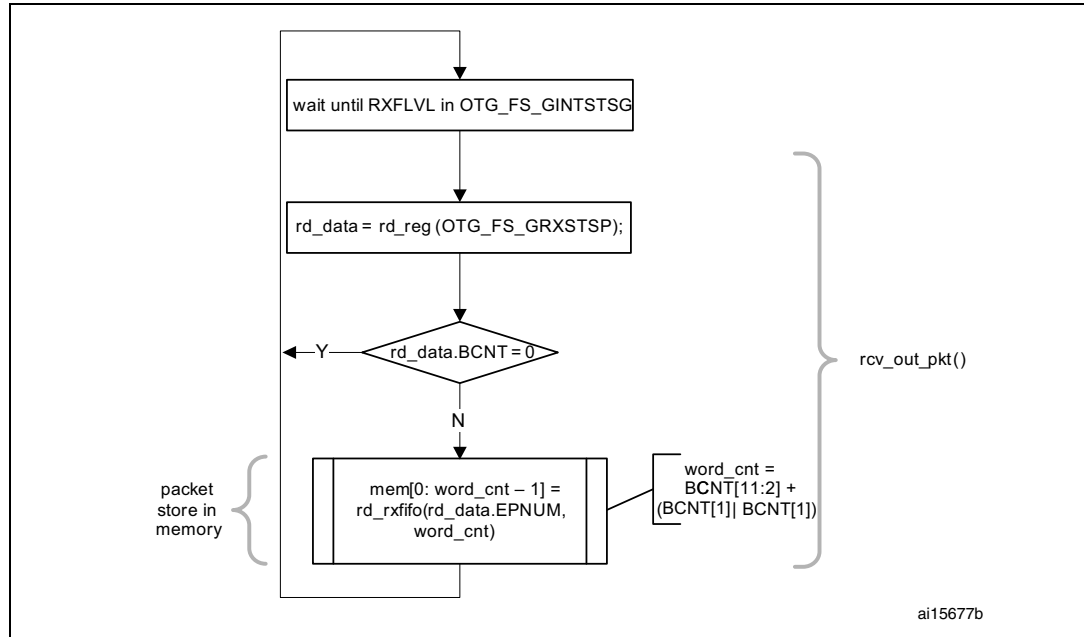


completed. After this entry is popped from the receive FIFO, the core asserts a Transfer Completed interrupt on the specified OUT endpoint.

5. After the data payload is popped from the receive FIFO, the RXFLVL interrupt (OTG\_FS\_GINTSTS) must be unmasked.
6. Steps 1–5 are repeated every time the application detects assertion of the interrupt line due to RXFLVL in OTG\_FS\_GINTSTS. Reading an empty receive FIFO can result in undefined core behavior.

Figure 317 provides a flowchart of the above procedure.

**Figure 317. Receive FIFO packet read**



● **SETUP transactions**

This section describes how the core handles SETUP packets and the application’s sequence for handling SETUP transactions.

● **Application requirements**

1. To receive a SETUP packet, the STUPCNT field (OTG\_FS\_DOEPTSIZx) in a control OUT endpoint must be programmed to a non-zero value. When the application programs the STUPCNT field to a non-zero value, the core receives SETUP packets and writes them to the receive FIFO, irrespective of the NAK status and EPENA bit setting in OTG\_FS\_DOEPCTLx. The STUPCNT field is decremented every time the control endpoint receives a SETUP packet. If the STUPCNT field is not programmed to a proper value before receiving a SETUP packet, the core still receives the SETUP packet and decrements the STUPCNT field, but the application may not be able to

determine the correct number of SETUP packets received in the Setup stage of a control transfer.

- STUPCNT = 3 in OTG\_FS\_DOEPTSIZE
2. The application must always allocate some extra space in the Receive data FIFO, to be able to receive up to three SETUP packets on a control endpoint.
    - The space to be reserved is 10 Words. Three Words are required for the first SETUP packet, 1 Word is required for the Setup stage done Word and 6 Words are required to store two extra SETUP packets among all control endpoints.
    - 3 Words per SETUP packet are required to store 8 bytes of SETUP data and 4 bytes of SETUP status (Setup packet pattern). The core reserves this space in the receive data.
    - FIFO to write SETUP data only, and never uses this space for data packets.
  3. The application must read the 2 Words of the SETUP packet from the receive FIFO.
  4. The application must read and discard the Setup stage done Word from the receive FIFO.

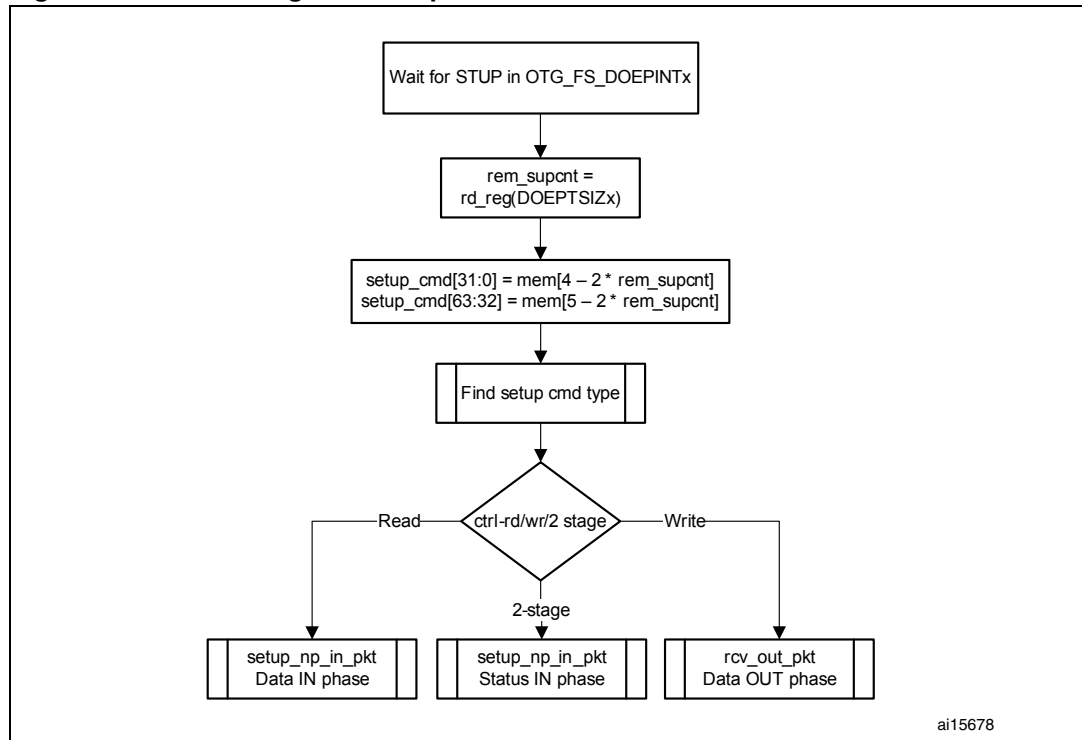
● **Internal data flow**

5. When a SETUP packet is received, the core writes the received data to the receive FIFO, without checking for available space in the receive FIFO and irrespective of the endpoint's NAK and STALL bit settings.
  - The core internally sets the IN NAK and OUT NAK bits for the control IN/OUT endpoints on which the SETUP packet was received.
6. For every SETUP packet received on the USB, 3 Words of data are written to the receive FIFO, and the STUPCNT field is decremented by 1.
  - The first Word contains control information used internally by the core
  - The second Word contains the first 4 bytes of the SETUP command
  - The third Word contains the last 4 bytes of the SETUP command
7. When the Setup stage changes to a Data IN/OUT stage, the core writes an entry (Setup stage done Word) to the receive FIFO, indicating the completion of the Setup stage.
8. On the AHB side, SETUP packets are emptied by the application.
9. When the application pops the Setup stage done Word from the receive FIFO, the core interrupts the application with an STUP interrupt (OTG\_FS\_DOEPINTx), indicating it can process the received SETUP packet.
  - The core clears the endpoint enable bit for control OUT endpoints.

● **Application programming sequence**

1. Program the OTG\_FS\_DOEPTSIZE register.
  - STUPCNT = 3
2. Wait for the RXFLVL interrupt (OTG\_FS\_GINTSTS) and empty the data packets from the receive FIFO.
3. Assertion of the STUP interrupt (OTG\_FS\_DOEPINTx) marks a successful completion of the SETUP Data Transfer.
  - On this interrupt, the application must read the OTG\_FS\_DOEPTSIZE register to determine the number of SETUP packets received and process the last received SETUP packet.

Figure 318. Processing a SETUP packet



- **Handling more than three back-to-back SETUP packets**

Per the USB 2.0 specification, normally, during a SETUP packet error, a host does not send more than three back-to-back SETUP packets to the same endpoint. However, the USB 2.0 specification does not limit the number of back-to-back SETUP packets a host can send to the same endpoint. When this condition occurs, the OTG\_FS controller generates an interrupt (B2BSTUP in OTG\_FS\_DOEPINTx).

- **Setting the global OUT NAK**

Internal data flow:

1. When the application sets the Global OUT NAK (SGONAK bit in OTG\_FS\_DCTL), the core stops writing data, except SETUP packets, to the receive FIFO. Irrespective of the space availability in the receive FIFO, non-isochronous OUT tokens receive a NAK handshake response, and the core ignores isochronous OUT data packets
2. The core writes the Global OUT NAK pattern to the receive FIFO. The application must reserve enough receive FIFO space to write this data pattern.
3. When the application pops the Global OUT NAK pattern Word from the receive FIFO, the core sets the GONAKEFF interrupt (OTG\_FS\_GINTSTS).
4. Once the application detects this interrupt, it can assume that the core is in Global OUT NAK mode. The application can clear this interrupt by clearing the SGONAK bit in OTG\_FS\_DCTL.

Application programming sequence

1. To stop receiving any kind of data in the receive FIFO, the application must set the Global OUT NAK bit by programming the following field:
  - SGONAK = 1 in OTG\_FS\_DCTL
2. Wait for the assertion of the GONAKEFF interrupt in OTG\_FS\_GINTSTS. When asserted, this interrupt indicates that the core has stopped receiving any type of data except SETUP packets.
3. The application can receive valid OUT packets after it has set SGONAK in OTG\_FS\_DCTL and before the core asserts the GONAKEFF interrupt (OTG\_FS\_GINTSTS).
4. The application can temporarily mask this interrupt by writing to the GINAKEFFM bit in the OTG\_FS\_GINTMSK register.
  - GINAKEFFM = 0 in the OTG\_FS\_GINTMSK register
5. Whenever the application is ready to exit the Global OUT NAK mode, it must clear the SGONAK bit in OTG\_FS\_DCTL. This also clears the GONAKEFF interrupt (OTG\_FS\_GINTSTS).
  - OTG\_FS\_DCTL = 1 in CGONAK
6. If the application has masked this interrupt earlier, it must be unmasked as follows:
  - GINAKEFFM = 1 in GINTMSK

#### ● Disabling an OUT endpoint

The application must use this sequence to disable an OUT endpoint that it has enabled.

Application programming sequence:

1. Before disabling any OUT endpoint, the application must enable Global OUT NAK mode in the core.
  - SGONAK = 1 in OTG\_FS\_DCTL
2. Wait for the GONAKEFF interrupt (OTG\_FS\_GINTSTS)
3. Disable the required OUT endpoint by programming the following fields:
  - EPDIS = 1 in OTG\_FS\_DOEPCTLx
  - SNAK = 1 in OTG\_FS\_DOEPCTLx
4. Wait for the EPDISD interrupt (OTG\_FS\_DOEPINTx), which indicates that the OUT endpoint is completely disabled. When the EPDISD interrupt is asserted, the core also clears the following bits:
  - EPDIS = 0 in OTG\_FS\_DOEPCTLx
  - EPENA = 0 in OTG\_FS\_DOEPCTLx
5. The application must clear the Global OUT NAK bit to start receiving data from other non-disabled OUT endpoints.
  - SGONAK = 0 in OTG\_FS\_DCTL

#### ● Generic non-isochronous OUT data transfers

This section describes a regular non-isochronous OUT data transfer (control, bulk, or interrupt).

Application requirements:

1. Before setting up an OUT transfer, the application must allocate a buffer in the memory to accommodate all data to be received as part of the OUT transfer.
2. For OUT transfers, the transfer size field in the endpoint's transfer size register must be a multiple of the maximum packet size of the endpoint, adjusted to the Word boundary.
  - $\text{transfer size}[\text{EPNUM}] = n \times (\text{MPSIZ}[\text{EPNUM}] + 4 - (\text{MPSIZ}[\text{EPNUM}] \bmod 4))$
  - $\text{packet count}[\text{EPNUM}] = n$
  - $n > 0$
3. On any OUT endpoint interrupt, the application must read the endpoint's transfer size register to calculate the size of the payload in the memory. The received payload size can be less than the programmed transfer size.
  - $\text{Payload size in memory} = \text{application programmed initial transfer size} - \text{core updated final transfer size}$
  - $\text{Number of USB packets in which this payload was received} = \text{application programmed initial packet count} - \text{core updated final packet count}$

Internal data flow:

1. The application must set the transfer size and packet count fields in the endpoint-specific registers, clear the NAK bit, and enable the endpoint to receive the data.
2. Once the NAK bit is cleared, the core starts receiving data and writes it to the receive FIFO, as long as there is space in the receive FIFO. For every data packet received on the USB, the data packet and its status are written to the receive FIFO. Every packet (maximum packet size or short packet) written to the receive FIFO decrements the packet count field for that endpoint by 1.
  - OUT data packets received with bad data CRC are flushed from the receive FIFO automatically.
  - After sending an ACK for the packet on the USB, the core discards non-isochronous OUT data packets that the host, which cannot detect the ACK, re-sends. The application does not detect multiple back-to-back data OUT packets on the same endpoint with the same data PID. In this case the packet count is not decremented.
  - If there is no space in the receive FIFO, isochronous or non-isochronous data packets are ignored and not written to the receive FIFO. Additionally, non-isochronous OUT tokens receive a NAK handshake reply.
  - In all the above three cases, the packet count is not decremented because no data are written to the receive FIFO.
3. When the packet count becomes 0 or when a short packet is received on the endpoint, the NAK bit for that endpoint is set. Once the NAK bit is set, the isochronous or non-isochronous data packets are ignored and not written to the receive FIFO, and non-isochronous OUT tokens receive a NAK handshake reply.
4. After the data are written to the receive FIFO, the application reads the data from the receive FIFO and writes it to external memory, one packet at a time per endpoint.
5. At the end of every packet write on the AHB to external memory, the transfer size for the endpoint is decremented by the size of the written packet.

6. The OUT data transfer completed pattern for an OUT endpoint is written to the receive FIFO on one of the following conditions:
  - The transfer size is 0 and the packet count is 0
  - The last OUT data packet written to the receive FIFO is a short packet ( $0 \leq \text{packet size} < \text{maximum packet size}$ )
7. When either the application pops this entry (OUT data transfer completed), a transfer completed interrupt is generated for the endpoint and the endpoint enable is cleared.

Application programming sequence:

1. Program the OTG\_FS\_DOEPTSIZE register for the transfer size and the corresponding packet count.
2. Program the OTG\_FS\_DOEPCTL register with the endpoint characteristics, and set the EPENA and CNAK bits.
  - EPENA = 1 in OTG\_FS\_DOEPCTL
  - CNAK = 1 in OTG\_FS\_DOEPCTL
3. Wait for the RXFLVL interrupt (in OTG\_FS\_GINTSTS) and empty the data packets from the receive FIFO.
  - This step can be repeated many times, depending on the transfer size.
4. Asserting the XFRC interrupt (OTG\_FS\_DOEPINT) marks a successful completion of the non-isochronous OUT data transfer.
5. Read the OTG\_FS\_DOEPTSIZE register to determine the size of the received data payload.

#### ● Generic isochronous OUT data transfer

This section describes a regular isochronous OUT data transfer.

Application requirements:

1. All the application requirements for non-isochronous OUT data transfers also apply to isochronous OUT data transfers.
2. For isochronous OUT data transfers, the transfer size and packet count fields must always be set to the number of maximum-packet-size packets that can be received in a single frame and no more. Isochronous OUT data transfers cannot span more than 1 frame.
3. The application must read all isochronous OUT data packets from the receive FIFO (data and status) before the end of the periodic frame (EOPF interrupt in OTG\_FS\_GINTSTS).
4. To receive data in the following frame, an isochronous OUT endpoint must be enabled after the EOPF (OTG\_FS\_GINTSTS) and before the SOF (OTG\_FS\_GINTSTS).

Internal data flow:

1. The internal data flow for isochronous OUT endpoints is the same as that for non-isochronous OUT endpoints, but for a few differences.
2. When an isochronous OUT endpoint is enabled by setting the Endpoint Enable and clearing the NAK bits, the Even/Odd frame bit must also be set appropriately. The core receives data on an isochronous OUT endpoint in a particular frame only if the following condition is met:
  - EONUM (in OTG\_FS\_DOEPCTL) = SOFFN[0] (in OTG\_FS\_DSTS)
3. When the application completely reads an isochronous OUT data packet (data and status) from the receive FIFO, the core updates the RXDPID field in

OTG\_FS\_DOEPTSIZE with the data PID of the last isochronous OUT data packet read from the receive FIFO.

Application programming sequence:

1. Program the OTG\_FS\_DOEPTSIZE register for the transfer size and the corresponding packet count
2. Program the OTG\_FS\_DOEPCTL register with the endpoint characteristics and set the Endpoint Enable, ClearNAK, and Even/Odd frame bits.
  - EPENA = 1
  - CNAK = 1
  - EONUM = (0: Even/1: Odd)
3. Wait for the RXFLVL interrupt (in OTG\_FS\_GINTSTS) and empty the data packets from the receive FIFO
  - This step can be repeated many times, depending on the transfer size.
4. The assertion of the XFRC interrupt (in OTG\_FS\_DOEPINT) marks the completion of the isochronous OUT data transfer. This interrupt does not necessarily mean that the data in memory are good.
5. This interrupt cannot always be detected for isochronous OUT transfers. Instead, the application can detect the IISOXFRM interrupt in OTG\_FS\_GINTSTS.
6. Read the OTG\_FS\_DOEPTSIZE register to determine the size of the received transfer and to determine the validity of the data received in the frame. The application must treat the data received in memory as valid only if one of the following conditions is met:
  - RXDPID = D0 (in OTG\_FS\_DOEPTSIZE) and the number of USB packets in which this payload was received = 1
  - RXDPID = D1 (in OTG\_FS\_DOEPTSIZE) and the number of USB packets in which this payload was received = 2
  - RXDPID = D2 (in OTG\_FS\_DOEPTSIZE) and the number of USB packets in which this payload was received = 3

The number of USB packets in which this payload was received =  
Application programmed initial packet count – Core updated final packet count

The application can discard invalid data packets.

#### ● Incomplete isochronous OUT data transfers

This section describes the application programming sequence when isochronous OUT data packets are dropped inside the core.

Internal data flow:

1. For isochronous OUT endpoints, the XFRC interrupt (in OTG\_FS\_DOEPINT) may not always be asserted. If the core drops isochronous OUT data packets, the application could fail to detect the XFRC interrupt (OTG\_FS\_DOEPINT) under the following circumstances:
  - When the receive FIFO cannot accommodate the complete ISO OUT data packet, the core drops the received ISO OUT data
  - When the isochronous OUT data packet is received with CRC errors
  - When the isochronous OUT token received by the core is corrupted
  - When the application is very slow in reading the data from the receive FIFO
2. When the core detects an end of periodic frame before transfer completion to all isochronous OUT endpoints, it asserts the incomplete Isochronous OUT data interrupt

(IISOOXFRM in OTG\_FS\_GINTSTS), indicating that an XFRC interrupt (in OTG\_FS\_DOEPINTx) is not asserted on at least one of the isochronous OUT endpoints. At this point, the endpoint with the incomplete transfer remains enabled, but no active transfers remain in progress on this endpoint on the USB.

Application programming sequence:

1. Asserting the IISOOXFRM interrupt (OTG\_FS\_GINTSTS) indicates that in the current frame, at least one isochronous OUT endpoint has an incomplete transfer.
2. If this occurs because isochronous OUT data is not completely emptied from the endpoint, the application must ensure that the application empties all isochronous OUT data (data and status) from the receive FIFO before proceeding.
  - When all data are emptied from the receive FIFO, the application can detect the XFRC interrupt (OTG\_FS\_DOEPINTx). In this case, the application must re-enable the endpoint to receive isochronous OUT data in the next frame.
3. When it receives an IISOOXFRM interrupt (in OTG\_FS\_GINTSTS), the application must read the control registers of all isochronous OUT endpoints (OTG\_FS\_DOEPCTLx) to determine which endpoints had an incomplete transfer in the current microframe. An endpoint transfer is incomplete if both the following conditions are met:
  - EONUM bit (in OTG\_FS\_DOEPCTLx) = SOFFN[0] (in OTG\_FS\_DSTS)
  - EPENA = 1 (in OTG\_FS\_DOEPCTLx)
4. The previous step must be performed before the SOF interrupt (in OTG\_FS\_GINTSTS) is detected, to ensure that the current frame number is not changed.
5. For isochronous OUT endpoints with incomplete transfers, the application must discard the data in the memory and disable the endpoint by setting the EPDIS bit in OTG\_FS\_DOEPCTLx.
6. Wait for the EPDIS interrupt (in OTG\_FS\_DOEPINTx) and enable the endpoint to receive new data in the next frame.
  - Because the core can take some time to disable the endpoint, the application may not be able to receive the data in the next frame after receiving bad isochronous data.

#### ● **Stalling a non-isochronous OUT endpoint**

This section describes how the application can stall a non-isochronous endpoint.

1. Put the core in the Global OUT NAK mode.
2. Disable the required endpoint
  - When disabling the endpoint, instead of setting the SNAK bit in OTG\_FS\_DOEPCTL, set STALL = 1 (in OTG\_FS\_DOEPCTL).  
The STALL bit always takes precedence over the NAK bit.
3. When the application is ready to end the STALL handshake for the endpoint, the STALL bit (in OTG\_FS\_DOEPCTLx) must be cleared.
4. If the application is setting or clearing a STALL for an endpoint due to a SetFeature.Endpoint Halt or ClearFeature.Endpoint Halt command, the STALL bit must be set or cleared before the application sets up the Status stage transfer on the control endpoint.



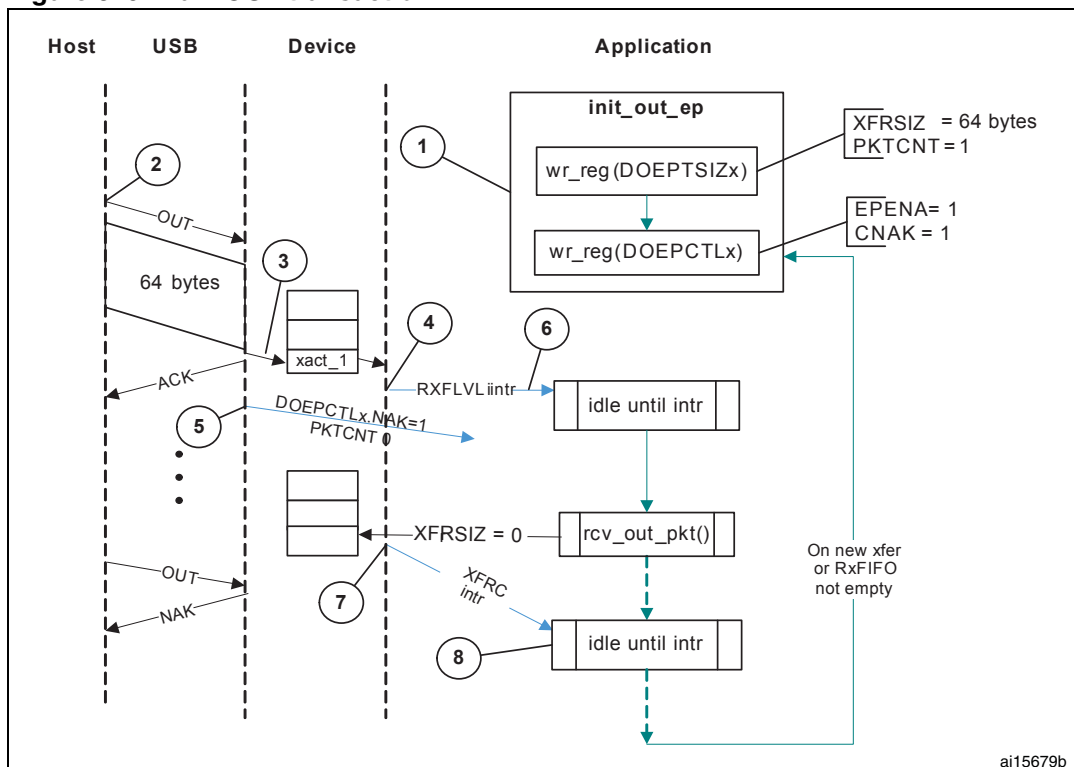
### Examples

This section describes and depicts some fundamental transfer types and scenarios.

- Bulk OUT transaction

Figure 319 depicts the reception of a single Bulk OUT Data packet from the USB to the AHB and describes the events involved in the process.

Figure 319. Bulk OUT transaction



After a SetConfiguration/SetInterface command, the application initializes all OUT endpoints by setting CNAK = 1 and EPENA = 1 (in OTG\_FS\_DOEPCTLx), and setting a suitable XFRSIZ and PKTCNT in the OTG\_FS\_DOEPSIZx register.

1. Host attempts to send data (OUT token) to an endpoint.
2. When the core receives the OUT token on the USB, it stores the packet in the RxFIFO because space is available there.
3. After writing the complete packet in the RxFIFO, the core then asserts the RXFLVL interrupt (in OTG\_FS\_GINTSTS).
4. On receiving the PKTCNT number of USB packets, the core internally sets the NAK bit for this endpoint to prevent it from receiving any more packets.
5. The application processes the interrupt and reads the data from the RxFIFO.
6. When the application has read all the data (equivalent to XFRSIZ), the core generates an XFRC interrupt (in OTG\_FS\_DOEPINTx).
7. The application processes the interrupt and uses the setting of the XFRC interrupt bit (in OTG\_FS\_DOEPINTx) to determine that the intended transfer is complete.

## IN data transfers

### ● Packet write

This section describes how the application writes data packets to the endpoint FIFO when dedicated transmit FIFOs are enabled.

1. The application can either choose the polling or the interrupt mode.
  - In polling mode, the application monitors the status of the endpoint transmit data FIFO by reading the OTG\_FS\_DTXFSTSx register, to determine if there is enough space in the data FIFO.
  - In interrupt mode, the application waits for the TXFE interrupt (in OTG\_FS\_DIEPINTx) and then reads the OTG\_FS\_DTXFSTSx register, to determine if there is enough space in the data FIFO.
  - To write a single non-zero length data packet, there must be space to write the entire packet in the data FIFO.
  - To write zero length packet, the application must not look at the FIFO space.
2. Using one of the above mentioned methods, when the application determines that there is enough space to write a transmit packet, the application must first write into the endpoint control register, before writing the data into the data FIFO. Typically, the application, must do a read modify write on the OTG\_FS\_DIEPCTLx register to avoid modifying the contents of the register, except for setting the Endpoint Enable bit.

The application can write multiple packets for the same endpoint into the transmit FIFO, if space is available. For periodic IN endpoints, the application must write packets only for one microframe. It can write packets for the next periodic transaction only after getting transfer complete for the previous transaction.

### ● Setting IN endpoint NAK

Internal data flow:

1. When the application sets the IN NAK for a particular endpoint, the core stops transmitting data on the endpoint, irrespective of data availability in the endpoint's transmit FIFO.
2. Non-isochronous IN tokens receive a NAK handshake reply
  - Isochronous IN tokens receive a zero-data-length packet reply
3. The core asserts the INEPNE (IN endpoint NAK effective) interrupt in OTG\_FS\_DIEPINTx in response to the SNAK bit in OTG\_FS\_DIEPCTLx.
4. Once this interrupt is seen by the application, the application can assume that the endpoint is in IN NAK mode. This interrupt can be cleared by the application by setting the CNAK bit in OTG\_FS\_DIEPCTLx.

Application programming sequence:

1. To stop transmitting any data on a particular IN endpoint, the application must set the IN NAK bit. To set this bit, the following field must be programmed.
  - SNAK = 1 in OTG\_FS\_DIEPCTLx
2. Wait for assertion of the INEPNE interrupt in OTG\_FS\_DIEPINTx. This interrupt indicates that the core has stopped transmitting data on the endpoint.
3. The core can transmit valid IN data on the endpoint after the application has set the NAK bit, but before the assertion of the NAK Effective interrupt.
4. The application can mask this interrupt temporarily by writing to the INEPNEM bit in DIEPMSK.
  - INEPNEM = 0 in DIEPMSK
5. To exit Endpoint NAK mode, the application must clear the NAK status bit (NAKSTS) in OTG\_FS\_DIEPCTLx. This also clears the INEPNE interrupt (in OTG\_FS\_DIEPINTx).
  - CNAK = 1 in OTG\_FS\_DIEPCTLx
6. If the application masked this interrupt earlier, it must be unmasked as follows:
  - INEPNEM = 1 in DIEPMSK

● **IN endpoint disable**

Use the following sequence to disable a specific IN endpoint that has been previously enabled.

Application programming sequence:

1. The application must stop writing data on the AHB for the IN endpoint to be disabled.
2. The application must set the endpoint in NAK mode.
  - SNAK = 1 in OTG\_FS\_DIEPCTLx
3. Wait for the INEPNE interrupt in OTG\_FS\_DIEPINTx.
4. Set the following bits in the OTG\_FS\_DIEPCTLx register for the endpoint that must be disabled.
  - EPDIS = 1 in OTG\_FS\_DIEPCTLx
  - SNAK = 1 in OTG\_FS\_DIEPCTLx
5. Assertion of the EPDISD interrupt in OTG\_FS\_DIEPINTx indicates that the core has completely disabled the specified endpoint. Along with the assertion of the interrupt, the core also clears the following bits:
  - EPENA = 0 in OTG\_FS\_DIEPCTLx
  - EPDIS = 0 in OTG\_FS\_DIEPCTLx
6. The application must read the OTG\_FS\_DIEPTSIZx register for the periodic IN EP, to calculate how much data on the endpoint were transmitted on the USB.
7. The application must flush the data in the Endpoint transmit FIFO, by setting the following fields in the OTG\_FS\_GRSTCTL register:
  - TXFNUM (in OTG\_FS\_GRSTCTL) = Endpoint transmit FIFO number
  - TXFFLSH in (OTG\_FS\_GRSTCTL) = 1

The application must poll the OTG\_FS\_GRSTCTL register, until the TXFFLSH bit is cleared by the core, which indicates the end of flush operation. To transmit new data on this endpoint, the application can re-enable the endpoint at a later point.

- **Generic non-periodic IN data transfers**

Application requirements:

1. Before setting up an IN transfer, the application must ensure that all data to be transmitted as part of the IN transfer are part of a single buffer.
2. For IN transfers, the Transfer Size field in the Endpoint Transfer Size register denotes a payload that constitutes multiple maximum-packet-size packets and a single short packet. This short packet is transmitted at the end of the transfer.
  - To transmit a few maximum-packet-size packets and a short packet at the end of the transfer:
 
$$\text{Transfer size[EPNUM]} = x \times \text{MPSIZ[EPNUM]} + \text{sp}$$
 If (sp > 0), then packet count[EPNUM] = x + 1.  
 Otherwise, packet count[EPNUM] = x
  - To transmit a single zero-length data packet:
 
$$\text{Transfer size[EPNUM]} = 0$$

$$\text{Packet count[EPNUM]} = 1$$
  - To transmit a few maximum-packet-size packets and a zero-length data packet at the end of the transfer, the application must split the transfer into two parts. The first sends maximum-packet-size data packets and the second sends the zero-length data packet alone.
 
$$\text{First transfer: transfer size[EPNUM]} = x \times \text{MPSIZ[epnum]}; \text{ packet count} = n;$$

$$\text{Second transfer: transfer size[EPNUM]} = 0; \text{ packet count} = 1;$$
3. Once an endpoint is enabled for data transfers, the core updates the Transfer size register. At the end of the IN transfer, the application must read the Transfer size register to determine how much data posted in the transmit FIFO have already been sent on the USB.
4. Data fetched into transmit FIFO = Application-programmed initial transfer size – core-updated final transfer size
  - Data transmitted on USB = (application-programmed initial packet count – Core updated final packet count) × MPSIZ[EPNUM]
  - Data yet to be transmitted on USB = (Application-programmed initial transfer size – data transmitted on USB)

Internal data flow:

1. The application must set the transfer size and packet count fields in the endpoint-specific registers and enable the endpoint to transmit the data.
2. The application must also write the required data to the transmit FIFO for the endpoint.
3. Every time a packet is written into the transmit FIFO by the application, the transfer size for that endpoint is decremented by the packet size. The data is fetched from the memory by the application, until the transfer size for the endpoint becomes 0. After writing the data into the FIFO, the “number of packets in FIFO” count is incremented (this is a 3-bit count, internally maintained by the core for each IN endpoint transmit FIFO. The maximum number of packets maintained by the core at any time in an IN endpoint FIFO is eight). For zero-length packets, a separate flag is set for each FIFO, without any data in the FIFO.
4. Once the data are written to the transmit FIFO, the core reads them out upon receiving an IN token. For every non-isochronous IN data packet transmitted with an ACK

handshake, the packet count for the endpoint is decremented by one, until the packet count is zero. The packet count is not decremented on a timeout.

5. For zero length packets (indicated by an internal zero length flag), the core sends out a zero-length packet for the IN token and decrements the packet count field.
6. If there are no data in the FIFO for a received IN token and the packet count field for that endpoint is zero, the core generates an “IN token received when TxFIFO is empty” (ITTXFE) Interrupt for the endpoint, provided that the endpoint NAK bit is not set. The core responds with a NAK handshake for non-isochronous endpoints on the USB.
7. The core internally rewinds the FIFO pointers and no timeout interrupt is generated.
8. When the transfer size is 0 and the packet count is 0, the transfer complete (XFRC) interrupt for the endpoint is generated and the endpoint enable is cleared.

Application programming sequence:

1. Program the OTG\_FS\_DIEPTSIZx register with the transfer size and corresponding packet count.
2. Program the OTG\_FS\_DIEPCTLx register with the endpoint characteristics and set the CNAK and EPENA (Endpoint Enable) bits.
3. When transmitting non-zero length data packet, the application must poll the OTG\_FS\_DTXFSTSx register (where x is the FIFO number associated with that endpoint) to determine whether there is enough space in the data FIFO. The application can optionally use TXFE (in OTG\_FS\_DIEPINTx) before writing the data.

#### ● Generic periodic IN data transfers

This section describes a typical periodic IN data transfer.

Application requirements:

1. Application requirements 1, 2, 3, and 4 of [Generic non-periodic IN data transfers on page 900](#) also apply to periodic IN data transfers, except for a slight modification of requirement 2.
  - The application can only transmit multiples of maximum-packet-size data packets or multiples of maximum-packet-size packets, plus a short packet at the end. To transmit a few maximum-packet-size packets and a short packet at the end of the transfer, the following conditions must be met:
 
$$\text{transfer size[EPNUM]} = x \times \text{MPSIZ[EPNUM]} + \text{sp}$$
 (where  $x$  is an integer  $\geq 0$ , and  $0 \leq \text{sp} < \text{MPSIZ[EPNUM]}$ )
 
$$\text{If } (\text{sp} > 0), \text{ packet count[EPNUM]} = x + 1$$
 Otherwise,  $\text{packet count[EPNUM]} = x$ ;
 
$$\text{MCNT[EPNUM]} = \text{packet count[EPNUM]}$$
  - The application cannot transmit a zero-length data packet at the end of a transfer. It can transmit a single zero-length data packet by itself. To transmit a single zero-length data packet:
 
$$\text{transfer size[EPNUM]} = 0$$

$$\text{packet count[EPNUM]} = 1$$

$$\text{MCNT[EPNUM]} = \text{packet count[EPNUM]}$$

2. The application can only schedule data transfers one frame at a time.
  - $(MCNT - 1) \times MPSIZ \leq XFERSIZ \leq MCNT \times MPSIZ$
  - $PKTCNT = MCNT$  (in OTG\_FS\_DIEPTSIZx)
  - If  $XFERSIZ < MCNT \times MPSIZ$ , the last data packet of the transfer is a short packet.
  - Note that: MCNT is in OTG\_FS\_DIEPTSIZx, MPSIZ is in OTG\_FS\_DIEPCTLx, PKTCNT is in OTG\_FS\_DIEPTSIZx and XFERSIZ is in OTG\_FS\_DIEPTSIZx
3. The complete data to be transmitted in the frame must be written into the transmit FIFO by the application, before the IN token is received. Even when 1 Word of the data to be transmitted per frame is missing in the transmit FIFO when the IN token is received, the core behaves as when the FIFO is empty. When the transmit FIFO is empty:
  - A zero data length packet would be transmitted on the USB for isochronous IN endpoints
  - A NAK handshake would be transmitted on the USB for interrupt IN endpoints

Internal data flow:

1. The application must set the transfer size and packet count fields in the endpoint-specific registers and enable the endpoint to transmit the data.
2. The application must also write the required data to the associated transmit FIFO for the endpoint.
3. Every time the application writes a packet to the transmit FIFO, the transfer size for that endpoint is decremented by the packet size. The data are fetched from application memory until the transfer size for the endpoint becomes 0.
4. When an IN token is received for a periodic endpoint, the core transmits the data in the FIFO, if available. If the complete data payload (complete packet, in dedicated FIFO mode) for the frame is not present in the FIFO, then the core generates an IN token received when TxFIFO empty interrupt for the endpoint.
  - A zero-length data packet is transmitted on the USB for isochronous IN endpoints
  - A NAK handshake is transmitted on the USB for interrupt IN endpoints
5. The packet count for the endpoint is decremented by 1 under the following conditions:
  - For isochronous endpoints, when a zero- or non-zero-length data packet is transmitted
  - For interrupt endpoints, when an ACK handshake is transmitted
  - When the transfer size and packet count are both 0, the transfer completed interrupt for the endpoint is generated and the endpoint enable is cleared.
6. At the “Periodic frame Interval” (controlled by PFIVL in OTG\_FS\_DCFG), when the core finds non-empty any of the isochronous IN endpoint FIFOs scheduled for the current frame non-empty, the core generates an IISOIXFR interrupt in OTG\_FS\_GINTSTS.

Application programming sequence:

1. Program the OTG\_FS\_DIEPCTLx register with the endpoint characteristics and set the CNAK and EPENA bits.
2. Write the data to be transmitted in the next frame to the transmit FIFO.
3. Asserting the ITTXFE interrupt (in OTG\_FS\_DIEPINTx) indicates that the application has not yet written all data to be transmitted to the transmit FIFO.
4. If the interrupt endpoint is already enabled when this interrupt is detected, ignore the interrupt. If it is not enabled, enable the endpoint so that the data can be transmitted on the next IN token attempt.
5. Asserting the XFRC interrupt (in OTG\_FS\_DIEPINTx) with no ITTXFE interrupt in OTG\_FS\_DIEPINTx indicates the successful completion of an isochronous IN transfer. A read to the OTG\_FS\_DIEPTSIZx register must give transfer size = 0 and packet count = 0, indicating all data were transmitted on the USB.
6. Asserting the XFRC interrupt (in OTG\_FS\_DIEPINTx), with or without the ITTXFE interrupt (in OTG\_FS\_DIEPINTx), indicates the successful completion of an interrupt IN transfer. A read to the OTG\_FS\_DIEPTSIZx register must give transfer size = 0 and packet count = 0, indicating all data were transmitted on the USB.
7. Asserting the incomplete isochronous IN transfer (IISOIXFR) interrupt in OTG\_FS\_GINTSTS with none of the aforementioned interrupts indicates the core did not receive at least 1 periodic IN token in the current frame.

- **Incomplete isochronous IN data transfers**

This section describes what the application must do on an incomplete isochronous IN data transfer.

Internal data flow:

1. An isochronous IN transfer is treated as incomplete in one of the following conditions:
  - a) The core receives a corrupted isochronous IN token on at least one isochronous IN endpoint. In this case, the application detects an incomplete isochronous IN transfer interrupt (IISOIXFR in OTG\_FS\_GINTSTS).
  - b) The application is slow to write the complete data payload to the transmit FIFO and an IN token is received before the complete data payload is written to the FIFO. In this case, the application detects an IN token received when TxFIFO empty interrupt in OTG\_FS\_DIEPINTx. The application can ignore this interrupt, as it eventually results in an incomplete isochronous IN transfer interrupt (IISOIXFR in OTG\_FS\_GINTSTS) at the end of periodic frame.  
The core transmits a zero-length data packet on the USB in response to the received IN token.
2. The application must stop writing the data payload to the transmit FIFO as soon as possible.
3. The application must set the NAK bit and the disable bit for the endpoint.
4. The core disables the endpoint, clears the disable bit, and asserts the Endpoint Disable interrupt for the endpoint.

Application programming sequence:

1. The application can ignore the IN token received when TxFIFO empty interrupt in OTG\_FS\_DIEPINTx on any isochronous IN endpoint, as it eventually results in an incomplete isochronous IN transfer interrupt (in OTG\_FS\_GINTSTS).
2. Assertion of the incomplete isochronous IN transfer interrupt (in OTG\_FS\_GINTSTS) indicates an incomplete isochronous IN transfer on at least one of the isochronous IN endpoints.
3. The application must read the Endpoint Control register for all isochronous IN endpoints to detect endpoints with incomplete IN data transfers.
4. The application must stop writing data to the Periodic Transmit FIFOs associated with these endpoints on the AHB.
5. Program the following fields in the OTG\_FS\_DIEPCTLx register to disable the endpoint:
  - SNAK = 1 in OTG\_FS\_DIEPCTLx
  - EPDIS = 1 in OTG\_FS\_DIEPCTLx
6. The assertion of the Endpoint Disabled interrupt in OTG\_FS\_DIEPINTx indicates that the core has disabled the endpoint.
  - At this point, the application must flush the data in the associated transmit FIFO or overwrite the existing data in the FIFO by enabling the endpoint for a new transfer in the next microframe. To flush the data, the application must use the OTG\_FS\_GRSTCTL register.

#### ● Stalling non-isochronous IN endpoints

This section describes how the application can stall a non-isochronous endpoint.

Application programming sequence:

1. Disable the IN endpoint to be stalled. Set the STALL bit as well.
2. EPDIS = 1 in OTG\_FS\_DIEPCTLx, when the endpoint is already enabled
  - STALL = 1 in OTG\_FS\_DIEPCTLx
  - The STALL bit always takes precedence over the NAK bit
3. Assertion of the Endpoint Disabled interrupt (in OTG\_FS\_DIEPINTx) indicates to the application that the core has disabled the specified endpoint.
4. The application must flush the non-periodic or periodic transmit FIFO, depending on the endpoint type. In case of a non-periodic endpoint, the application must re-enable the other non-periodic endpoints that do not need to be stalled, to transmit data.
5. Whenever the application is ready to end the STALL handshake for the endpoint, the STALL bit must be cleared in OTG\_FS\_DIEPCTLx.
6. If the application sets or clears a STALL bit for an endpoint due to a SetFeature.Endpoint Halt command or ClearFeature.Endpoint Halt command, the STALL bit must be set or cleared before the application sets up the Status stage transfer on the control endpoint.

Special case: stalling the control OUT endpoint

The core must stall IN/OUT tokens if, during the data stage of a control transfer, the host sends more IN/OUT tokens than are specified in the SETUP packet. In this case, the application must enable the ITTXFE interrupt in OTG\_FS\_DIEPINTx and the OTEPDIS interrupt in OTG\_FS\_DOEPINTx during the data stage of the control transfer, after the core has transferred the amount of data specified in the SETUP packet. Then, when the



application receives this interrupt, it must set the STALL bit in the corresponding endpoint control register, and clear this interrupt.

### 27.16.7 Worst case response time

When the OTG\_FS controller acts as a device, there is a worst case response time for any tokens that follow an isochronous OUT. This worst case response time depends on the AHB clock frequency.

The core registers are in the AHB domain, and the core does not accept another token before updating these register values. The worst case is for any token following an isochronous OUT, because for an isochronous transaction, there is no handshake and the next token could come sooner. This worst case value is 7 PHY clocks when the AHB clock is the same as the PHY clock. When the AHB clock is faster, this value is smaller.

If this worst case condition occurs, the core responds to bulk/interrupt tokens with a NAK and drops isochronous and SETUP tokens. The host interprets this as a timeout condition for SETUP and retries the SETUP packet. For isochronous transfers, the Incomplete isochronous IN transfer interrupt (IISOIXFR) and Incomplete isochronous OUT transfer interrupt (IISOOXFR) inform the application that isochronous IN/OUT packets were dropped.

#### Choosing the value of TRDT in OTG\_FS\_GUSBCFG

The value in TRDT (OTG\_FS\_GUSBCFG) is the time it takes for the MAC, in terms of PHY clocks after it has received an IN token, to get the FIFO status, and thus the first data from the PFC block. This time involves the synchronization delay between the PHY and AHB clocks. The worst case delay for this is when the AHB clock is the same as the PHY clock. In this case, the delay is 5 clocks.

Once the MAC receives an IN token, this information (token received) is synchronized to the AHB clock by the PFC (the PFC runs on the AHB clock). The PFC then reads the data from the SPRAM and writes them into the dual clock source buffer. The MAC then reads the data out of the source buffer (4 deep).

If the AHB is running at a higher frequency than the PHY, the application can use a smaller value for TRDT (in OTG\_FS\_GUSBCFG).

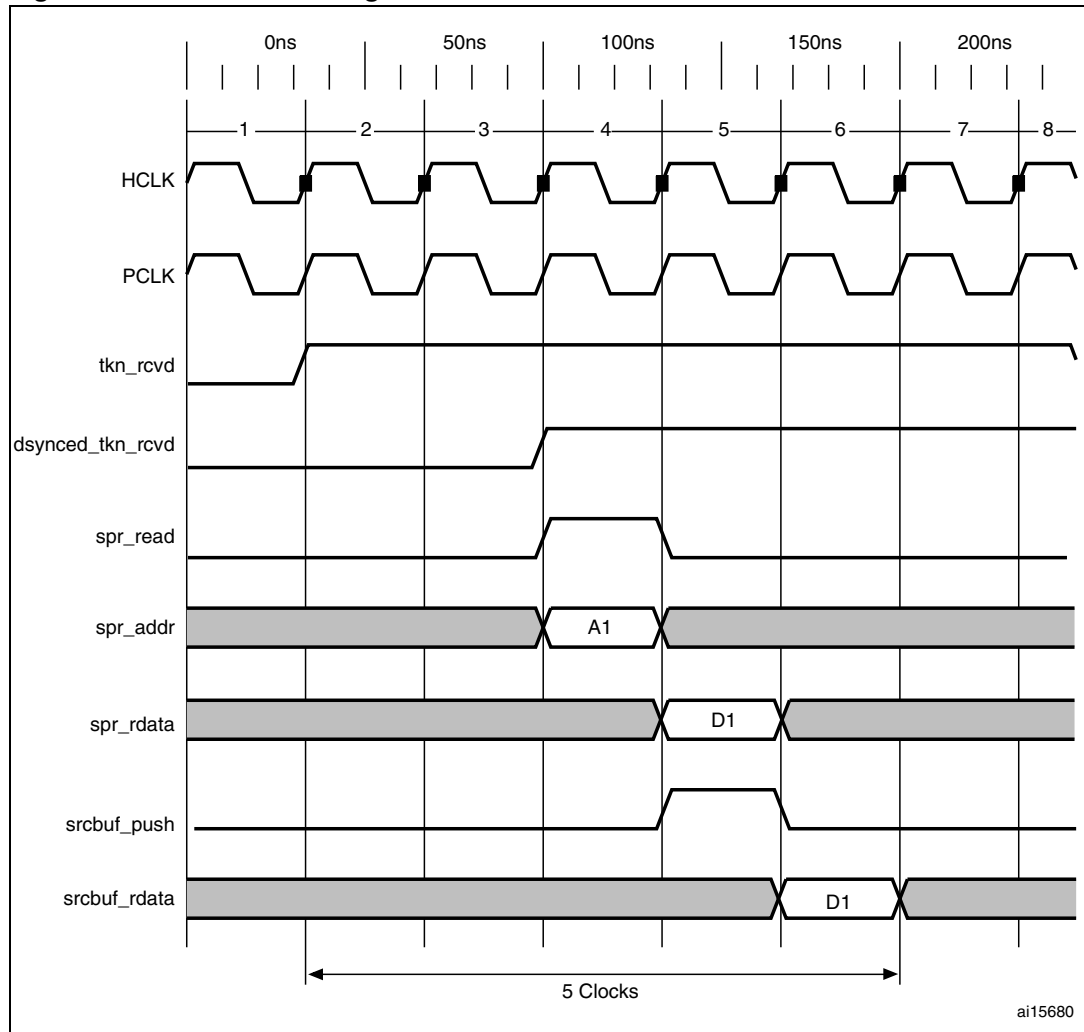
*Figure 320* has the following signals:

- tkn\_rcvd: Token received information from MAC to PFC
- dynced\_tkn\_rcvd: Doubled sync tkn\_rcvd, from PCLK to HCLK domain
- spr\_read: Read to SPRAM
- spr\_addr: Address to SPRAM
- spr\_rdata: Read data from SPRAM
- srcbuf\_push: Push to the source buffer
- srcbuf\_rdata: Read data from the source buffer. Data seen by MAC

The application can use the following formula to calculate the value of TRDT:

$$4 \times \text{AHB clock} + 1 \text{ PHY clock} = (2 \text{ clock sync} + 1 \text{ clock memory address} + 1 \text{ clock memory data from sync RAM}) + (1 \text{ PHY clock (next PHY clock MAC can sample the 2 clock FIFO outputs)})$$

Figure 320. TRDT max timing case



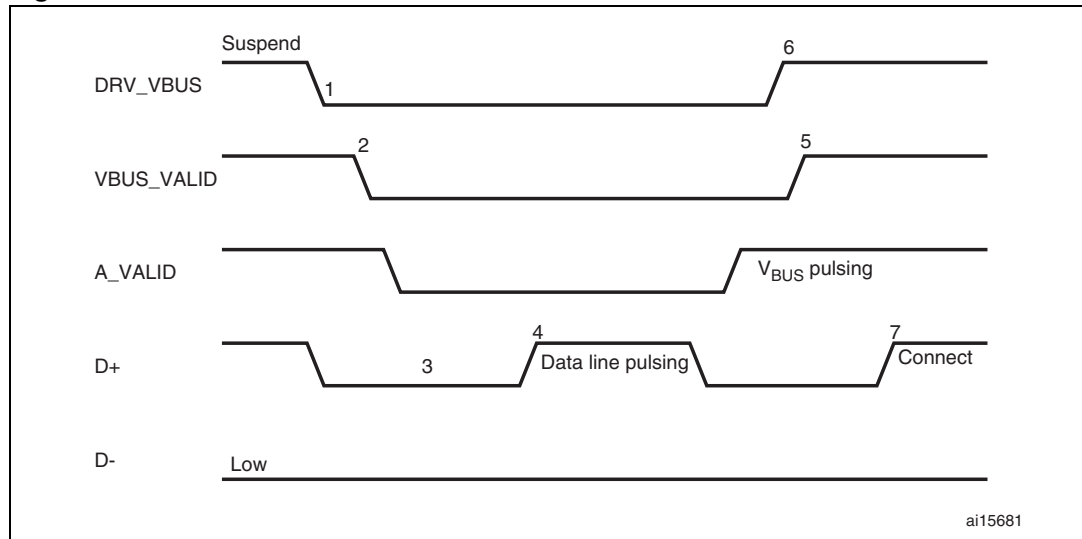
### 27.16.8 OTG programming model

The OTG\_FS controller is an OTG device supporting HNP and SRP. When the core is connected to an “A” plug, it is referred to as an A-device. When the core is connected to a “B” plug it is referred to as a B-device. In Host mode, the OTG\_FS controller turns off  $V_{BUS}$  to conserve power. SRP is a method by which the B-device signals the A-device to turn on  $V_{BUS}$  power. A device must perform both data-line pulsing and  $V_{BUS}$  pulsing, but a host can detect either data-line pulsing or  $V_{BUS}$  pulsing for SRP. HNP is a method by which the B-device negotiates and switches to host role. In Negotiated mode after HNP, the B-device suspends the bus and reverts to the device role.

#### A-device session request protocol

The application must set the SRP-capable bit in the Core USB configuration register. This enables the OTG\_FS controller to detect SRP as an A-device.

Figure 321. A-Device SRP



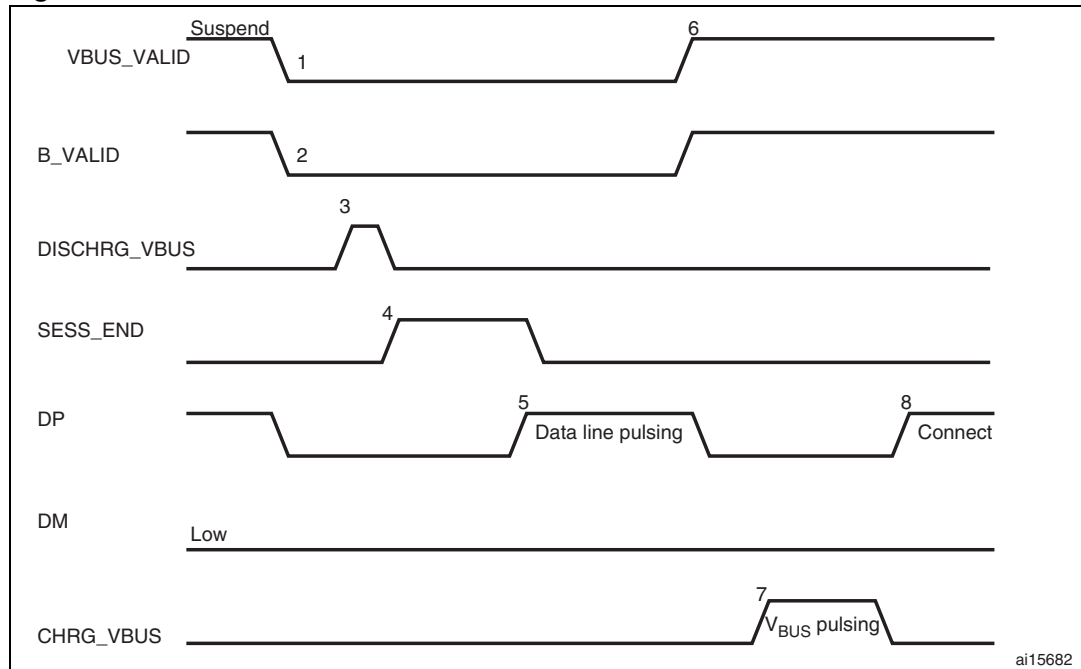
1. DRV\_VBUS =  $V_{BUS}$  drive signal to the PHY
- VBUS\_VALID =  $V_{BUS}$  valid signal from PHY
- A\_VALID = A-peripheral  $V_{BUS}$  level signal to PHY
- D+ = Data plus line
- D- = Data minus line

1. To save power, the application suspends and turns off port power when the bus is idle by writing the port suspend and port power bits in the Host port control and status register.
2. PHY indicates port power off by deasserting the VBUS\_VALID signal.
3. The device must detect SE0 for at least 2 ms to start SRP when  $V_{BUS}$  power is off.
4. To initiate SRP, the device turns on its data line pull-up resistor for 5 to 10 ms. The OTG\_FS controller detects data-line pulsing.
5. The device drives  $V_{BUS}$  above the A-device session valid (2.0 V minimum) for  $V_{BUS}$  pulsing.  
The OTG\_FS controller interrupts the application on detecting SRP. The Session request detected bit is set in Global interrupt status register (SRQINT set in OTG\_FS\_GINTSTS).
6. The application must service the Session request detected interrupt and turn on the port power bit by writing the port power bit in the Host port control and status register. The PHY indicates port power-on by asserting the VBUS\_VALID signal.
7. When the USB is powered, the device connects, completing the SRP process.

### B-device session request protocol

The application must set the SRP-capable bit in the Core USB configuration register. This enables the OTG\_FS controller to initiate SRP as a B-device. SRP is a means by which the OTG\_FS controller can request a new session from the host.

Figure 322. B-device SRP

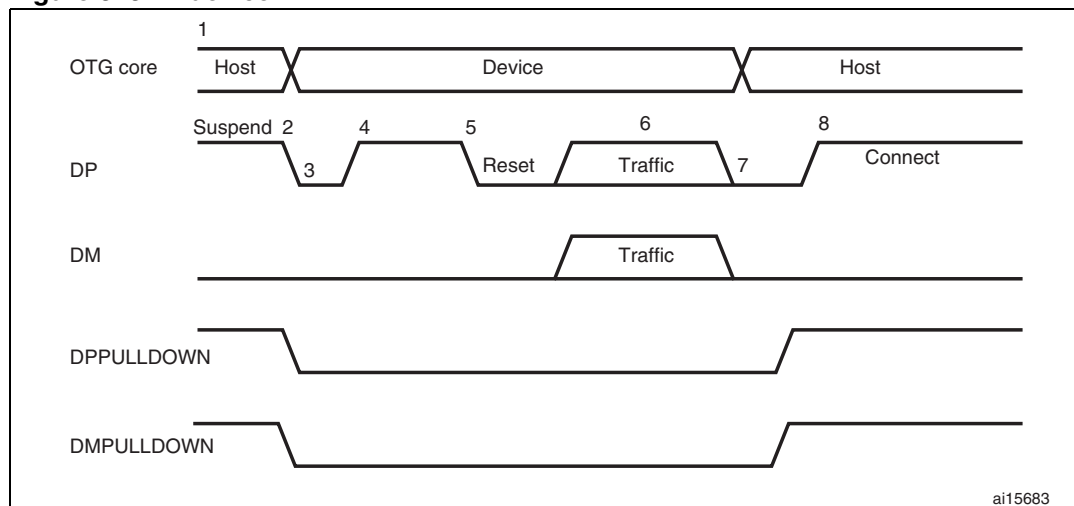


- 1. VBUS\_VALID =  $V_{BUS}$  valid signal from PHY  
 B\_VALID = B-peripheral valid session to PHY  
 DISCHRG\_VBUS = discharge signal to PHY  
 SESS\_END = session end signal to PHY  
 CHRGR\_VBUS = charge  $V_{BUS}$  signal to PHY  
 DP = Data plus line  
 DM = Data minus line
- 1. To save power, the host suspends and turns off port power when the bus is idle.  
 The OTG\_FS controller sets the early suspend bit in the Core interrupt register after 3 ms of bus idleness. Following this, the OTG\_FS controller sets the USB suspend bit in the Core interrupt register.  
 The OTG\_FS controller informs the PHY to discharge  $V_{BUS}$ .
- 2. The PHY indicates the session's end to the device. This is the initial condition for SRP. The OTG\_FS controller requires 2 ms of SE0 before initiating SRP.  
 For a USB 1.1 full-speed serial transceiver, the application must wait until  $V_{BUS}$  discharges to 0.2 V after BSVLD (in OTG\_FS\_GOTGCTL) is deasserted. This discharge time can be obtained from the transceiver vendor and varies from one transceiver to another.
- 3. The application initiates SRP by writing the session request bit in the OTG Control and status register. The OTG\_FS controller perform data-line pulsing followed by  $V_{BUS}$  pulsing.
- 4. The host detects SRP from either the data-line or  $V_{BUS}$  pulsing, and turns on  $V_{BUS}$ . The PHY indicates  $V_{BUS}$  power-on to the device.
- 5. The OTG\_FS controller performs  $V_{BUS}$  pulsing.  
 The host starts a new session by turning on  $V_{BUS}$ , indicating SRP success. The OTG\_FS controller interrupts the application by setting the session request success status change bit in the OTG interrupt status register. The application reads the session request success bit in the OTG control and status register.
- 6. When the USB is powered, the OTG\_FS controller connects, completing the SRP process.

## A-device host negotiation protocol

HNP switches the USB host role from the A-device to the B-device. The application must set the HNP-capable bit in the Core USB configuration register to enable the OTG\_FS controller to perform HNP as an A-device.

**Figure 323. A-device HNP**



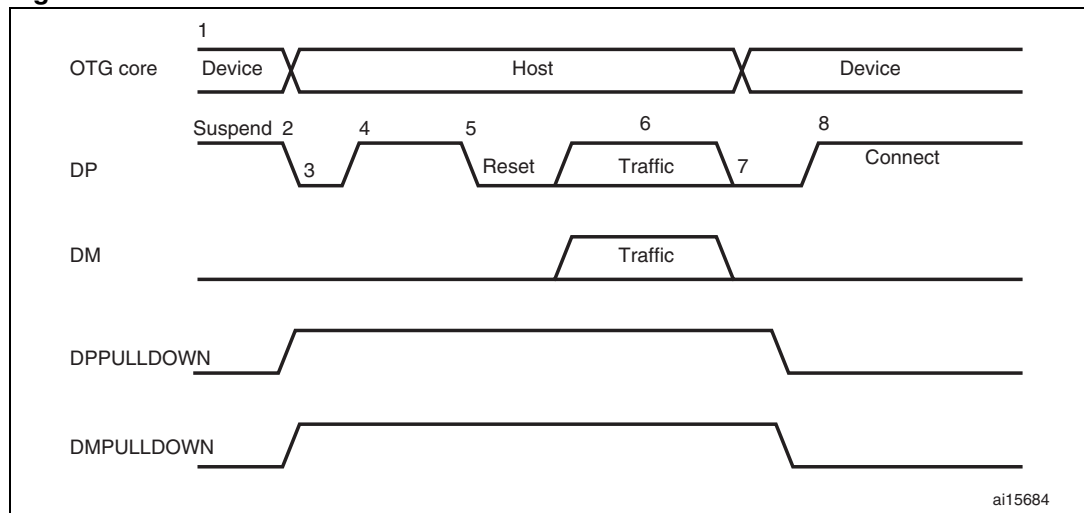
1. DPPULLDOWN = signal from core to PHY to enable/disable the pull-down on the DP line inside the PHY. DMPULLDOWN = signal from core to PHY to enable/disable the pull-down on the DM line inside the PHY.
1. The OTG\_FS controller sends the B-device a SetFeature b\_hnp\_enable descriptor to enable HNP support. The B-device's ACK response indicates that the B-device supports HNP. The application must set Host Set HNP Enable bit in the OTG Control and status register to indicate to the OTG\_FS controller that the B-device supports HNP.
2. When it has finished using the bus, the application suspends by writing the Port suspend bit in the Host port control and status register.
3. When the B-device observes a USB suspend, it disconnects, indicating the initial condition for HNP. The B-device initiates HNP only when it must switch to the host role; otherwise, the bus continues to be suspended.  
The OTG\_FS controller sets the Host negotiation detected interrupt in the OTG interrupt status register, indicating the start of HNP.  
The OTG\_FS controller deasserts the DM pull down and DM pull down in the PHY to indicate a device role. The PHY enables the OTG\_FS\_DP pull-up resistor to indicate a connect for B-device.  
The application must read the current mode bit in the OTG Control and status register to determine Device mode operation.
4. The B-device detects the connection, issues a USB reset, and enumerates the OTG\_FS controller for data traffic.
5. The B-device continues the host role, initiating traffic, and suspends the bus when done.  
The OTG\_FS controller sets the early suspend bit in the Core interrupt register after 3 ms of bus idleness. Following this, the OTG\_FS controller sets the USB Suspend bit in the Core interrupt register.

6. In Negotiated mode, the OTG\_FS controller detects the suspend, disconnects, and switches back to the host role. The OTG\_FS controller asserts the DM pull down and DP pull down in the PHY to indicate its assumption of the host role.
7. The OTG\_FS controller sets the Connector ID status change interrupt in the OTG Interrupt Status register. The application must read the connector ID status in the OTG Control and Status register to determine the OTG\_FS controller operation as an A-device. This indicates the completion of HNP to the application. The application must read the Current mode bit in the OTG control and status register to determine Host mode operation.
8. The B-device connects, completing the HNP process.

**B-device host negotiation protocol**

HNP switches the USB host role from B-device to A-device. The application must set the HNP-capable bit in the Core USB configuration register to enable the OTG\_FS controller to perform HNP as a B-device.

**Figure 324. B-device HNP**



1. DPPULLDOWN = signal from core to PHY to enable/disable the pull-down on the DP line inside the PHY. DMPULLDOWN = signal from core to PHY to enable/disable the pull-down on the DM line inside the PHY.
1. The A-device sends the SetFeature b\_hnp\_enable descriptor to enable HNP support. The OTG\_FS controller's ACK response indicates that it supports HNP. The application must set the Device HNP enable bit in the OTG Control and status register to indicate HNP support.
 

The application sets the HNP request bit in the OTG Control and status register to indicate to the OTG\_FS controller to initiate HNP.
2. When it has finished using the bus, the A-device suspends by writing the Port suspend bit in the Host port control and status register.
 

The OTG\_FS controller sets the Early suspend bit in the Core interrupt register after 3 ms of bus idleness. Following this, the OTG\_FS controller sets the USB suspend bit in the Core interrupt register.

The OTG\_FS controller disconnects and the A-device detects SE0 on the bus, indicating HNP. The OTG\_FS controller asserts the DP pull down and DM pull down in the PHY to indicate its assumption of the host role.

The A-device responds by activating its OTG\_FS\_DP pull-up resistor within 3 ms of detecting SE0. The OTG\_FS controller detects this as a connect.

The OTG\_FS controller sets the Host negotiation success status change interrupt in the OTG Interrupt status register, indicating the HNP status. The application must read the Host negotiation success bit in the OTG Control and status register to determine host negotiation success. The application must read the current Mode bit in the Core interrupt register (OTG\_FS\_GINTSTS) to determine Host mode operation.

3. The application sets the reset bit (PRST in OTG\_FS\_HPRT) and the OTG\_FS controller issues a USB reset and enumerates the A-device for data traffic.
4. The OTG\_FS controller continues the host role of initiating traffic, and when done, suspends the bus by writing the Port suspend bit in the Host port control and status register.
5. In Negotiated mode, when the A-device detects a suspend, it disconnects and switches back to the host role. The OTG\_FS controller deasserts the DP pull down and DM pull down in the PHY to indicate the assumption of the device role.
6. The application must read the current mode bit in the Core interrupt (OTG\_FS\_GINTSTS) register to determine the Host mode operation.
7. The OTG\_FS controller connects, completing the HNP process.

## 28 Ethernet (ETH): media access control (MAC) with DMA controller

**Low-density devices** are STM32F101xx, STM32F102xx and STM32F103xx microcontrollers where the Flash memory density ranges between 16 and 32 Kbytes.

**Medium-density devices** are STM32F101xx, STM32F102xx and STM32F103xx microcontrollers where the Flash memory density ranges between 64 and 128 Kbytes.

**High-density devices** are STM32F101xx and STM32F103xx microcontrollers where the Flash memory density ranges between 256 and 512 Kbytes.

**XL-density devices** are STM32F101xx and STM32F103xx microcontrollers where the Flash memory density ranges between 768 Kbytes and 1 Mbyte.

**Connectivity line devices** are STM32F105xx and STM32F107xx microcontrollers.

This section applies only to STM32F107xx connectivity line devices.

### 28.1 Ethernet introduction

Portions Copyright (c) 2004, 2005 Synopsys, Inc. All rights reserved. Used with permission.

The Ethernet peripheral enables the STM32F107xx to transmit and receive data over Ethernet in compliance with the IEEE 802.3-2002 standard.

The Ethernet provides a configurable, flexible peripheral to meet the needs of various applications and customers. It supports two industry standard interfaces to the external physical layer (PHY): the default media independent interface (MII) defined in the IEEE 802.3 specifications and the reduced media independent interface (RMII). It can be used in number of applications such as switches, network interface cards, etc.

The Ethernet is compliant with the following standards:

- IEEE 802.3-2002 for Ethernet MAC
- IEEE 1588-2002 standard for precision networked clock synchronization
- AMBA 2.0 for AHB Master/Slave ports
- RMII specification from RMII consortium

### 28.2 Ethernet main features

The Ethernet (ETH) peripheral includes the following features, listed by category:



## 28.2.1 MAC core features

- Supports 10/100 Mbit/s data transfer rates with external PHY interfaces
- IEEE 802.3-compliant MII interface to communicate with an external Fast Ethernet PHY
- Supports both full-duplex and half-duplex operations
  - Supports CSMA/CD Protocol for half-duplex operation
  - Supports IEEE 802.3x flow control for full-duplex operation
  - Optional forwarding of received pause control frames to the user application in full-duplex operation
  - Back-pressure support for half-duplex operation
  - Automatic transmission of zero-quanta pause frame on deassertion of flow control input in full-duplex operation
- Preamble and start-of-frame data (SFD) insertion in Transmit, and deletion in Receive paths
- Automatic CRC and pad generation controllable on a per-frame basis
- Options for automatic pad/CRC stripping on receive frames
- Programmable frame length to support Standard frames with sizes up to 16 KB
- Programmable interframe gap (40-96 bit times in steps of 8)
- Supports a variety of flexible address filtering modes:
  - Up to four 48-bit perfect (DA) address filters with masks for each byte
  - Up to three 48-bit SA address comparison check with masks for each byte
  - 64-bit Hash filter (optional) for multicast and unicast (DA) addresses
  - Option to pass all multicast addressed frames
  - Promiscuous mode support to pass all frames without any filtering for network monitoring
  - Passes all incoming packets (as per filter) with a status report
- Separate 32-bit status returned for transmission and reception packets
- Supports IEEE 802.1Q VLAN tag detection for reception frames
- Separate transmission, reception, and control interfaces to the Application
- Supports mandatory network statistics with RMON/MIB counters (RFC2819/RFC2665)
- MDIO interface for PHY device configuration and management
- Detection of LAN wakeup frames and AMD Magic Packet™ frames
- Receive feature for checksum off-load for received IPv4 and TCP packets encapsulated by the Ethernet frame
- Enhanced receive feature for checking IPv4 header checksum and TCP, UDP, or ICMP checksum encapsulated in IPv4 or IPv6 datagrams
- Support Ethernet frame time stamping as described in IEEE 1588-2002. Sixty-four-bit time stamps are given in each frame's transmit or receive status
- Two sets of FIFOs: a 2-KB Transmit FIFO with programmable threshold capability, and a 2-KB Receive FIFO with a configurable threshold (default of 64 bytes)
- Receive Status vectors inserted into the Receive FIFO after the EOF transfer enables multiple-frame storage in the Receive FIFO without requiring another FIFO to store those frames' Receive Status

- Option to filter all error frames on reception and not forward them to the application in Store-and-Forward mode
- Option to forward under-sized good frames
- Supports statistics by generating pulses for frames dropped or corrupted (due to overflow) in the Receive FIFO
- Supports Store and Forward mechanism for transmission to the MAC core
- Automatic generation of PAUSE frame control or back pressure signal to the MAC core based on Receive FIFO-fill (threshold configurable) level
- Handles automatic retransmission of Collision frames for transmission
- Discards frames on late collision, excessive collisions, excessive deferral and underrun conditions
- Software control to flush Tx FIFO
- Calculates and inserts IPv4 header checksum and TCP, UDP, or ICMP checksum in frames transmitted in Store-and-Forward mode
- Supports internal loopback on the MII for debugging

### 28.2.2 DMA features

- Supports all AHB burst types in the AHB Slave Interface
- Software can select the type of AHB burst (fixed or indefinite burst) in the AHB Master interface.
- Option to select address-aligned bursts from AHB master port
- Optimization for packet-oriented DMA transfers with frame delimiters
- Byte-aligned addressing for data buffer support
- Dual-buffer (ring) or linked-list (chained) descriptor chaining
- Descriptor architecture, allowing large blocks of data transfer with minimum CPU intervention;
- each descriptor can transfer up to 8 KB of data
- Comprehensive status reporting for normal operation and transfers with errors
- Individual programmable burst size for Transmit and Receive DMA Engines for optimal host bus utilization
- Programmable interrupt options for different operational conditions
- Per-frame Transmit/Receive complete interrupt control
- Round-robin or fixed-priority arbitration between Receive and Transmit engines
- Start/Stop modes
- Current Tx/Rx Buffer pointer as status registers
- Current Tx/Rx Descriptor pointer as status registers

### 28.2.3 PTP features

- Received and transmitted frames time stamping
- Coarse and fine correction methods
- Trigger interrupt when system time becomes greater than target time
- Pulse per second output (product alternate function output)

## 28.3 Ethernet pins

*Table 203* shows the MAC signals and the corresponding MII/RMII default or remapped signals. It also indicates the pins onto which the signals are input or output, and the pin configuration.

**Table 203. Ethernet pin configuration**

MAC signals	MII default	MII remap	RMII default	RMII remap	Pin	Pin configuration
ETH_MDC	MDC	-	MDC	-	PC1	AF output push-pull high-speed (50 MHz)
ETH_MII_TXD2	TXD2	-	-	-	PC2	AF output push-pull high-speed (50 MHz)
ETH_MII_TX_CLK	TX_CLK	-	-	-	PC3	Floating input (reset state)
ETH_MII_CRS	CRS	-	-	-	PA0	Floating input (reset state)
ETH_MII_RX_CLK ETH_RMII_REF_CLK	RX_CLK	-	REF_CLK	-	PA1	Floating input (reset state)
ETH_MDIO	MDIO	-	MDIO	-	PA2	AF output push-pull high-speed (50 MHz)
ETH_MII_COL	COL	-	-	-	PA3	Floating input (reset state)
ETH_MII_RX_DV ETH_RMII_CRS_DV	RX_DV	-	CRS_DV	-	PA7	Floating input (reset state)
ETH_MII_RXD0 ETH_RMII_RXD0	RXD0	-	RXD0	-	PC4	Floating input (reset state)
ETH_MII_RXD1 ETH_RMII_RXD1	RXD1	-	RXD1	-	PC5	Floating input (reset state)
ETH_MII_RXD2	RXD2	-	-	-	PB0	Floating input (reset state)
ETH_MII_RXD3	RXD3	-	-	-	PB1	Floating input (reset state)
ETH_MII_RX_ER	RX_ER	-	-	-	PB10	Floating input (reset state)
ETH_MII_TX_EN ETH_RMII_TX_EN	TX_EN	-	TX_EN	-	PB11	AF output push-pull high-speed (50 MHz)
ETH_MII_TXD0 ETH_RMII_TXD0	TXD0	-	TXD0	-	PB12	AF output push-pull high-speed (50 MHz)
ETH_MII_TXD1 ETH_RMII_TXD1	TXD1	-	TXD1	-	PB13	AF output push-pull high-speed (50 MHz)
ETH_PPS_OUT	PPS_OUT	-	PPS_OUT	-	PB5	AF output push-pull high-speed (50 MHz)
ETH_MII_TXD3	TXD3	-	-	-	PB8	AF output push-pull high-speed (50 MHz)
ETH_RMII_CRS_DV	-	RX_DV	-	CRS_DV	PD8	Floating input (reset state)
ETH_MII_RXD0 ETH_RMII_RXD0	-	RXD0	-	RXD0	PD9	Floating input (reset state)
ETH_MII_RXD1 ETH_RMII_RXD1	-	RXD1	-	RXD1	PD10	Floating input (reset state)

Table 203. Ethernet pin configuration (continued)

MAC signals	MII default	MII remap	RMII default	RMII remap	Pin	Pin configuration
ETH_MII_RXD2	-	RXD2	-	-	PD11	Floating input (reset state)
ETH_MII_RXD3	-	RXD3	-	-	PD12	Floating input (reset state)

## 28.4 Ethernet functional description: SMI, MII and RMII

The Ethernet peripheral consists of a MAC 802.3 (media access control) with a dedicated DMA controller. It supports both default media-independent interface (MII) and reduced media-independent interface (RMII) through one selection bit (refer to AFIO\_MAPR register).

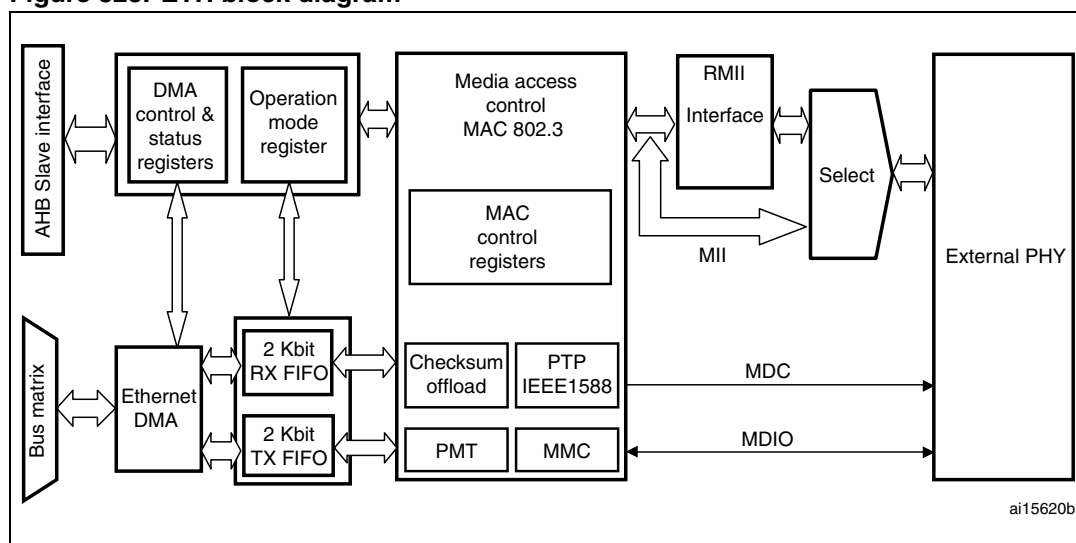
The DMA controller interfaces with the Core and memories through the AHB Master and Slave interfaces. The AHB Master Interface controls data transfers while the AHB Slave interface accesses Control and Status Registers (CSR) space.

The Transmit FIFO (Tx FIFO) buffers data read from system memory by the DMA before transmission by the MAC Core. Similarly, the Receive FIFO (Rx FIFO) stores the Ethernet frames received from the line until they are transferred to system memory by the DMA.

The Ethernet peripheral also includes an SMI to communicate with external PHY. A set of configuration registers permit the user to select the wanted mode and features for the MAC and the DMA controller.

*Note:* The AHB clock frequency must be at least 25 MHz when the Ethernet is used.

Figure 325. ETH block diagram



1. For AHB connections please refer to [Figure 2: System architecture in connectivity line devices](#).

### 28.4.1 Station management interface: SMI

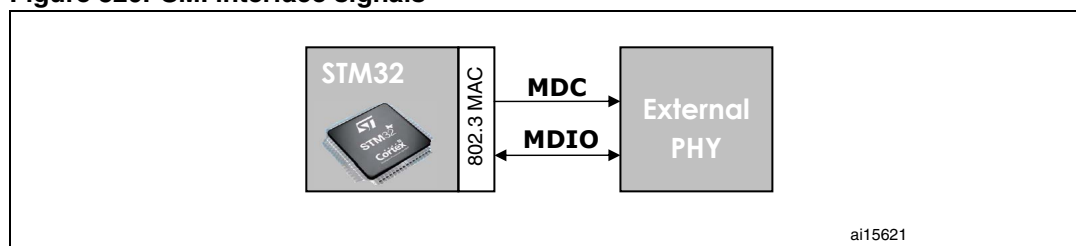
The station management interface (SMI) allows the application to access any PHY registers through a 2-wire clock and data lines. The interface supports accessing up to 32 PHYs.

The application can select one of the 32 PHYs and one of the 32 registers within any PHY and send control data or receive status information. Only one register in one PHY can be addressed at any given time.

Both the MDC clock line and the MDIO data line are implemented as alternate function I/O in the microcontroller:

- MDC: a periodic clock that provides the timing reference for the data transfer at the maximum frequency of 2.5 MHz. The minimum high and low times for MDC must be 160 ns each, and the minimum period for MDC must be 400 ns. In idle state the SMI management interface drives the MDC clock signal low.
- MDIO: data input/output bitstream to transfer status information to/from the PHY device synchronously with the MDC clock signal

Figure 326. SMI interface signals



SMI frame format

The frame structure related to a read or write operation is shown in Table 13, the order of bit transmission must be from left to right.

Table 204. Management frame format

	Management frame fields							
	Preamble (32 bits)	Start	Operation	PADDR	RADDR	TA	Data (16 bits)	Idle
Read	1... 1	01	10	ppppp	rrrrr	Z0	ddddddddddddddd	Z
Write	1... 1	01	01	ppppp	rrrrr	10	ddddddddddddddd	Z

The management frame consists of eight fields:

- **Preamble:** each transaction (read or write) can be initiated with the preamble field that corresponds to 32 contiguous logic one bits on the MDIO line with 32 corresponding cycles on MDC. This field is used to establish synchronization with the PHY device.
- **Start:** the start of frame is defined by a <01> pattern to verify transitions on the line from the default logic one state to zero and back to one.
- **Operation:** defines the type of transaction (read or write) in progress.
- **PADDR:** the PHY address is 5 bits, allowing 32 unique PHY addresses. The MSB bit of the address is the first transmitted and received.
- **RADDR:** the register address is 5 bits, allowing 32 individual registers to be addressed within the selected PHY device. The MSB bit of the address is the first transmitted and received.
- **TA:** the turn-around field defines a 2-bit pattern between the RADDR and DATA fields to avoid contention during a read transaction. For a read transaction the MAC controller

drives high-impedance on the MDIO line for the 2 bits of TA. The PHY device must drive a high-impedance state on the first bit of TA, a zero bit on the second one. For a write transaction, the MAC controller drives a <10> pattern during the TA field. The PHY device must drive a high-impedance state for the 2 bits of TA.

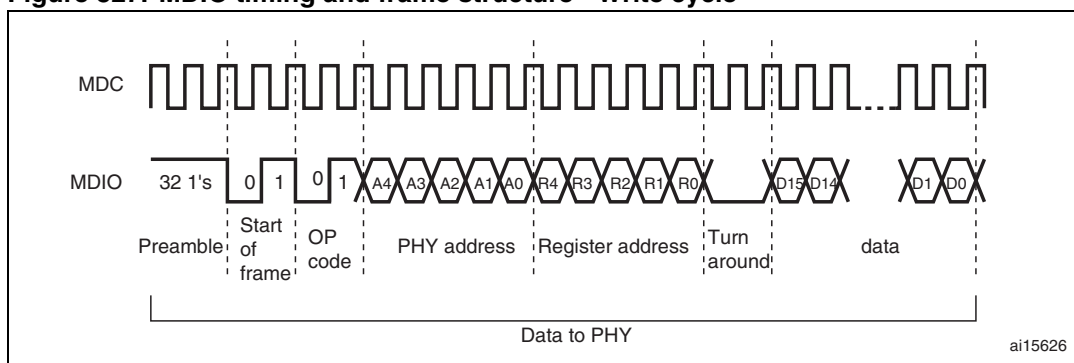
- **Data:** the data field is 16-bit. The first bit transmitted and received must be bit 15 of the ETH\_MIID register.
- **Idle:** the MDIO line is driven in high-impedance state. All three-state drivers must be disabled and the PHY’s pull-up resistor keeps the line at logic one.

**SMI write operation**

When the application sets the MII Write and Busy bits (in *Ethernet MAC MII address register (ETH\_MACMIIAR)*), the SMI initiates a write operation into the PHY registers by transferring the PHY address, the register address in PHY, and the write data (in *Ethernet MAC MII data register (ETH\_MACMIIDR)*). The application should not change the MII Address register contents or the MII Data register while the transaction is ongoing. Write operations to the MII Address register or the MII Data Register during this period are ignored (the Busy bit is high), and the transaction is completed without any error. After the Write operation has completed, the SMI indicates this by resetting the Busy bit.

Figure 327 shows the frame format for the write operation.

**Figure 327. MDIO timing and frame structure - Write cycle**

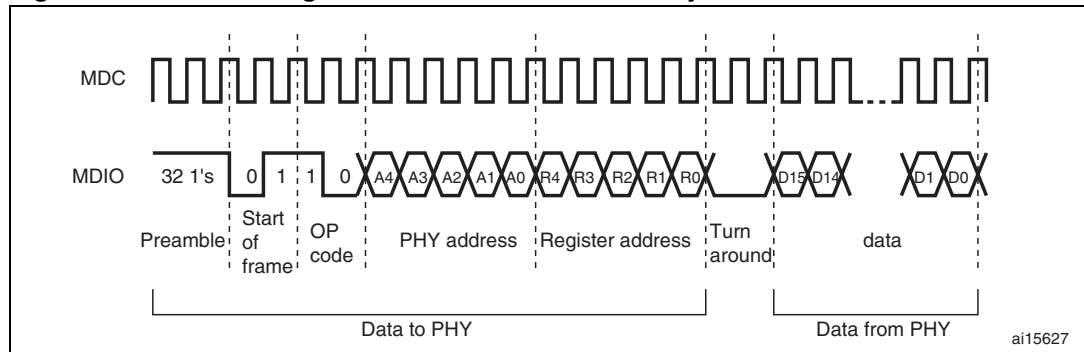


**SMI read operation**

When the user sets the MII Busy bit in the Ethernet MAC MII address register (ETH\_MACMIIAR) with the MII Write bit at 0, the SMI initiates a read operation in the PHY registers by transferring the PHY address and the register address in PHY. The application should not change the MII Address register contents or the MII Data register while the transaction is ongoing. Write operations to the MII Address register or MII Data Register during this period are ignored (the Busy bit is high) and the transaction is completed without any error. After the read operation has completed, the SMI resets the Busy bit and then updates the MII Data register with the data read from the PHY.

Figure 328 shows the frame format for the read operation.

Figure 328. MDIO timing and frame structure - Read cycle



**SMI clock selection**

The MAC initiates the Management Write/Read operation. The SMI clock is a divided clock whose source is the application clock (AHB clock). The divide factor depends on the clock range setting in the MII Address register.

Table 205 shows how to set the clock ranges.

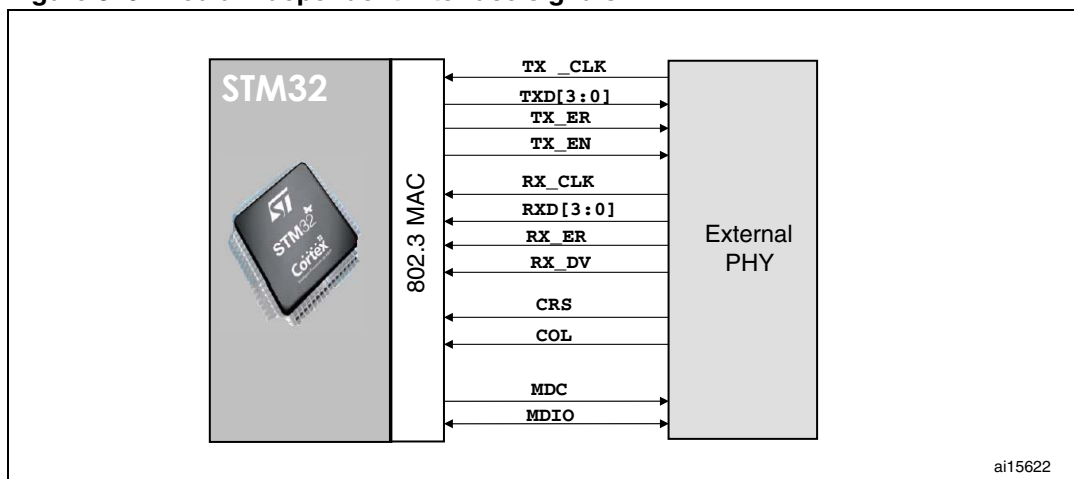
Table 205. Clock range

Selection	HCLK clock	MDC clock
0000	60-72 MHz	AHB clock / 42
0001	Reserved	-
0010	20-35 MHz	AHB clock / 16
0011	35-60 MHz	AHB clock / 26
0100, 0101, 0110, 0111	Reserved	-

**28.4.2 Media-independent interface: MII**

The media-independent interface (MII) defines the interconnection between the MAC sublayer and the PHY for data transfer at 10 Mbit/s and 100 Mbit/s.

Figure 329. Media independent interface signals



- **MII\_TX\_CLK**: continuous clock that provides the timing reference for the TX data transfer. The nominal frequency is: 2.5 MHz at 10 Mbit/s speed; 25 MHz at 100 Mbit/s speed.
- **MII\_RX\_CLK**: continuous clock that provides the timing reference for the RX data transfer. The nominal frequency is: 2.5 MHz at 10 Mbit/s speed; 25 MHz at 100 Mbit/s speed.
- **MII\_TX\_EN**: transmission enable indicates that the MAC is presenting nibbles on the MII for transmission. It must be asserted synchronously (MII\_TX\_CLK) with the first nibble of the preamble and must remain asserted while all nibbles to be transmitted are presented to the MII.
- **MII\_TXD[3:0]**: transmit data is a bundle of 4 data signals driven synchronously by the MAC sublayer and qualified (valid data) on the assertion of the MII\_TX\_EN signal. MII\_TXD[0] is the least significant bit, MII\_TXD[3] is the most significant bit. While MII\_TX\_EN is deasserted the transmit data must have no effect upon the PHY.
- **MII\_CR**: carrier sense is asserted by the PHY when either the transmit or receive medium is non idle. It shall be deasserted by the PHY when both the transmit and receive media are idle. The PHY must ensure that the MII\_CS signal remains asserted throughout the duration of a collision condition. This signal is not required to transition synchronously with respect to the TX and RX clocks. In full duplex mode the state of this signal is don't care for the MAC sublayer.
- **MII\_COL**: collision detection must be asserted by the PHY upon detection of a collision on the medium and must remain asserted while the collision condition persists. This signal is not required to transition synchronously with respect to the TX and RX clocks. In full duplex mode the state of this signal is don't care for the MAC sublayer.
- **MII\_RXD[3:0]**: reception data is a bundle of 4 data signals driven synchronously by the PHY and qualified (valid data) on the assertion of the MII\_RX\_DV signal. MII\_RXD[0] is the least significant bit, MII\_RXD[3] is the most significant bit. While MII\_RX\_EN is deasserted and MII\_RX\_ER is asserted, a specific MII\_RXD[3:0] value is used to transfer specific information from the PHY (see [Table 207](#)).
- **MII\_RX\_DV**: receive data valid indicates that the PHY is presenting recovered and decoded nibbles on the MII for reception. It must be asserted synchronously (MII\_RX\_CLK) with the first recovered nibble of the frame and must remain asserted through the final recovered nibble. It must be deasserted prior to the first clock cycle



that follows the final nibble. In order to receive the frame correctly, the MII\_RX\_DV signal must encompass the frame, starting no later than the SFD field.

- MII\_RX\_ER: receive error must be asserted for one or more clock periods (MII\_RX\_CLK) to indicate to the MAC sublayer that an error was detected somewhere in the frame. This error condition must be qualified by MII\_RX\_DV assertion as described in [Table 207](#).

**Table 206. TX interface signal encoding**

MII_TX_EN	MII_TXD[3:0]	Description
0	0000 through 1111	Normal inter-frame
1	0000 through 1111	Normal data transmission

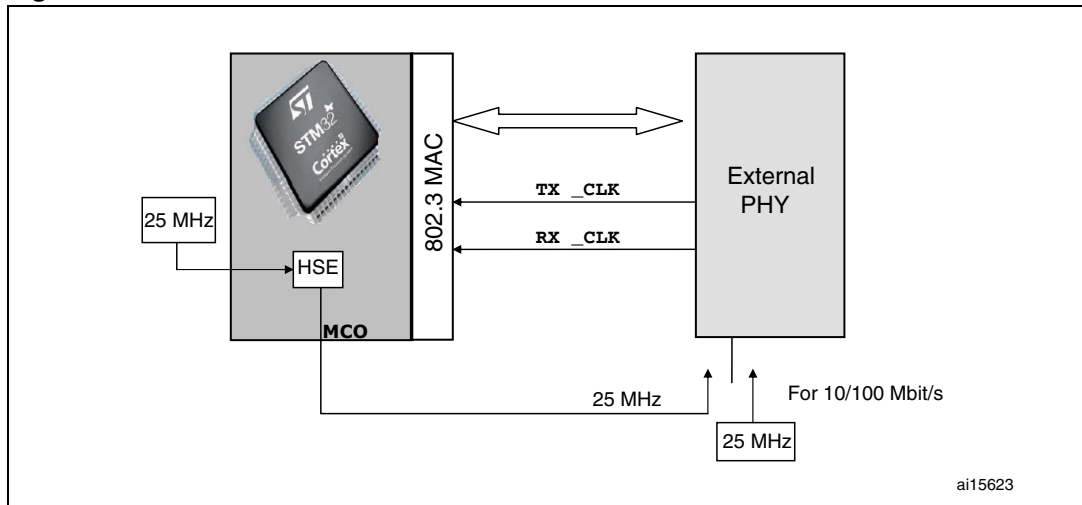
**Table 207. RX interface signal encoding**

MII_RX_DV	MII_RX_ERR	MII_RXD[3:0]	Description
0	0	0000 through 1111	Normal inter-frame
0	1	0000	Normal inter-frame
0	1	0001 through 1101	Reserved
0	1	1110	False carrier indication
0	1	1111	Reserved
1	0	0000 through 1111	Normal data reception
1	1	0000 through 1111	Data reception with errors

### MII clock sources

To generate both TX\_CLK and RX\_CLK clock signals, the external PHY must be clocked with an external 25 MHz as shown in [Figure 330](#). Instead of using an external 25 MHz quartz to provide this clock, the STM32F107xx microcontroller can output this signal on its MCO pin. In this case, the PLL multiplier has to be configured so as to get the desired frequency on the MCO pin, from the 25 MHz external quartz.

Figure 330. MII clock sources



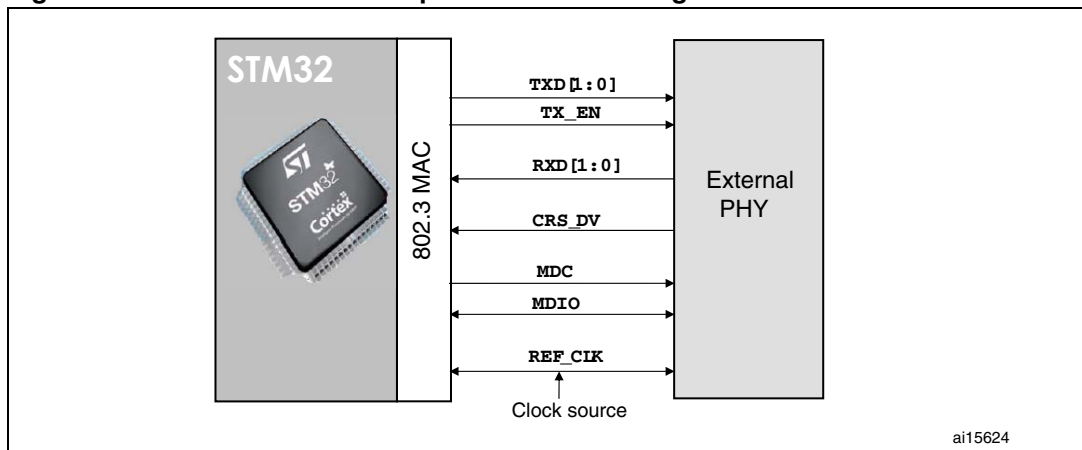
### 28.4.3 Reduced media-independent interface: RMII

The reduced media-independent interface (RMII) specification reduces the pin count between the STM32F100xx Ethernet peripheral and the external Ethernet in 10/100 Mbit/s. According to the IEEE 802.3u standard, an MII contains 16 pins for data and control. The RMII specification is dedicated to reduce the pin count to 7 pins (a 62.5% decrease in pin count).

The RMII is instantiated between the MAC and the PHY. This helps translation of the MAC’s MII into the RMII. The RMII block has the following characteristics:

- It supports 10-Mbit/s and 100-Mbit/s operating rates
- The clock reference must be doubled to 50 MHz
- The same clock reference must be sourced externally to both MAC and external Ethernet PHY
- It provides independent 2-bit wide (dibit) transmit and receive data paths

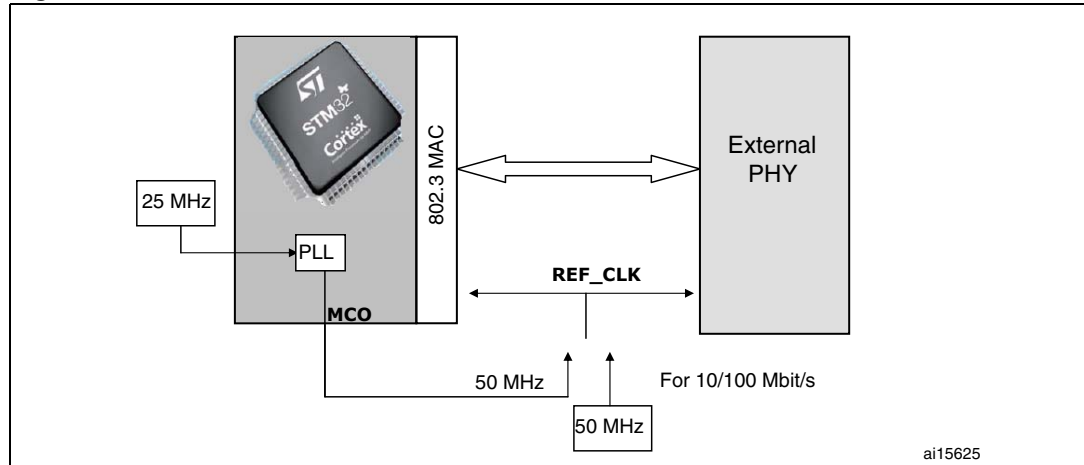
Figure 331. Reduced media-independent interface signals



**RMII clock sources**

As described in the *RMII clock sources* section, the STM32F107xx could provide this 50 MHz clock signal on its MCO output pin and you then have to configure this output value through PLL configuration.

**Figure 332. RMII clock sources**



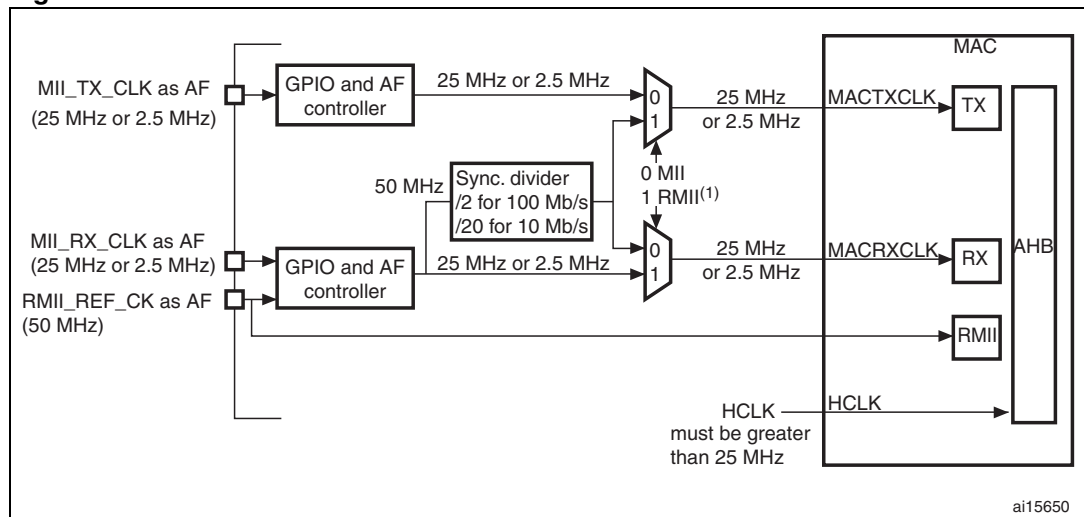
**28.4.4 MII/RMII selection**

The mode, MII or RMII, is selected using the configuration bit 23, MII\_RMII\_SEL, in the AFIO\_MAPR register. The application has to set the MII/RMII mode while the Ethernet controller is under reset or before enabling the clocks.

**MII/RMII internal clock scheme**

The clock scheme required to support both the MII and RMII, as well as 10 and 100 Mbit/s operations is described in *Figure 333*.

**Figure 333. Clock scheme**



1. The MII/RMII selection is controlled through bit 23, MII\_RMII\_SEL, in the AFIO\_MAPR register.

To save a pin, the two input clock signals, RMII\_REF\_CLK and MII\_RX\_CLK, are multiplexed on the same GPIO pin.

## 28.5 Ethernet functional description: MAC 802.3

The IEEE 802.3 International Standard for local area networks (LANs) employs the CSMA/CD (carrier sense multiple access with collision detection) as the access method.

The Ethernet peripheral consists of a MAC 802.3 (media access control) controller with media independent interface (MII) and a dedicated DMA controller.

The MAC block implements the LAN CSMA/CD sublayer for the following families of systems: 10 Mbit/s and 100 Mbit/s of data rates for baseband and broadband systems. Half- and full-duplex operation modes are supported. The collision detection access method is applied only to the half-duplex operation mode. The MAC control frame sublayer is supported.

The MAC sublayer performs the following functions associated with a data link control procedure:

- Data encapsulation (transmit and receive)
  - Framing (frame boundary delimitation, frame synchronization)
  - Addressing (handling of source and destination addresses)
  - Error detection
- Media access management
  - Medium allocation (collision avoidance)
  - Contention resolution (collision handling)

Basically there are two operating modes of the MAC sublayer:

- Half-duplex mode: the stations contend for the use of the physical medium, using the CSMA/CD algorithms.
- Full duplex mode: simultaneous transmission and reception without contention resolution (CSMA/CD algorithm are unnecessary) when all the following conditions are met:
  - physical medium capability to support simultaneous transmission and reception
  - exactly 2 stations connected to the LAN
  - both stations configured for full-duplex operation

### 28.5.1 MAC 802.3 frame format

The MAC block implements the MAC sublayer and the optional MAC control sublayer (10/100 Mbit/s) as specified by the IEEE 802.3-2002 standard.

Two frame formats are specified for data communication systems using the CSMA/CD MAC:

- Basic MAC frame format
- Tagged MAC frame format (extension of the basic MAC frame format)

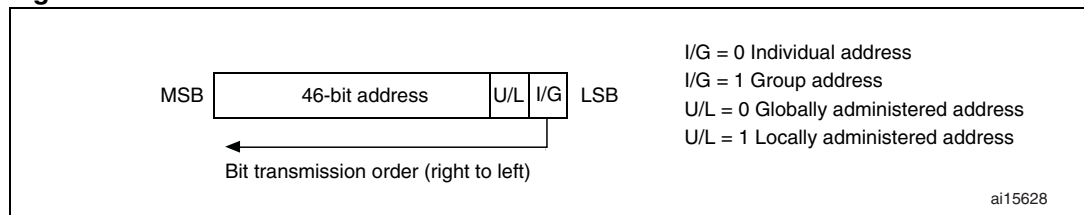
Figure 335 and Figure 336 describe the frame structure (untagged and tagged) that includes the following fields:

- Preamble: 7-byte field used for synchronization purposes (PLS circuitry)  
Hexadecimal value: 55-55-55-55-55-55-55  
Bit pattern: 01010101 01010101 01010101 01010101 01010101 01010101 01010101 (right-to-left bit transmission)
- Start frame delimiter (SFD): 1-byte field used to indicate the start of a frame.  
Hexadecimal value: D5  
Bit pattern: 11010101 (right-to-left bit transmission)
- Destination and Source Address fields: 6-byte fields to indicate the destination and source station addresses as follows (see Figure 334):
  - Each address is 48 bits in length
  - The first LSB bit (I/G) in the destination address field is used to indicate an individual (I/G = 0) or a group address (I/G = 1). A group address could identify none, one or more, or all the stations connected to the LAN. In the source address the first bit is reserved and reset to 0.
  - The second bit (U/L) distinguishes between locally (U/L = 1) or globally (U/L = 0) administered addresses. For broadcast addresses this bit is also 1.
  - Each byte of each address field must be transmitted least significant bit first.

The address designation is based on the following types:

- Individual address: this is the physical address associated with a particular station on the network.
- Group address. A multdestination address associated with one or more stations on a given network. There are two kinds of multicast address:
  - Multicast-group address: an address associated with a group of logically related stations.
  - Broadcast address: a distinguished, predefined multicast address (all 1's in the destination address field) that always denotes all the stations on a given LAN.

**Figure 334. Address field format**



- QTag Prefix: 4-byte field inserted between the Source address field and the MAC Client Length/Type field. This field is an extension of the basic frame (untagged) to obtain the tagged MAC frame. The untagged MAC frames do not include this field. The extensions for tagging are as follows:
  - 2-byte constant Length/Type field value consistent with the Type interpretation (greater than 0x0600) equal to the value of the 802.1Q Tag Protocol Type (0x8100)

hexadecimal). This constant field is used to distinguish tagged and untagged MAC frames.

- 2-byte field containing the Tag control information field subdivided as follows: a 3-bit user priority, a canonical format indicator (CFI) bit and a 12-bit VLAN Identifier. The length of the tagged MAC frame is extended by 4 bytes by the QTag Prefix.
- MAC client length/type: 2-byte field with different meaning (mutually exclusive), depending on its value:
  - If the value is less than or equal to `maxValidFrame` (0d1500) then this field indicates the number of MAC client data bytes contained in the subsequent data field of the 802.3 frame (length interpretation).
  - If the value is greater than or equal to `MinTypeValue` (0d1536 decimal, 0x0600) then this field indicates the nature of the MAC client protocol (Type interpretation) related to the Ethernet frame.

Regardless of the interpretation of the length/type field, if the length of the data field is less than the minimum required for proper operation of the protocol, a PAD field is added after the data field but prior to the FCS (frame check sequence) field. The length/type field is transmitted and received with the higher-order byte first.

For length/type field values in the range between `maxValidLength` and `minTypeValue` (boundaries excluded), the behavior of the MAC sublayer is not specified: they may or may not be passed by the MAC sublayer.

- Data and PAD fields: n-byte data field. Full data transparency is provided, it means that any arbitrary sequence of byte values may appear in the data field. The size of the PAD, if any, is determined by the size of the data field. Max and min length of the data and PAD field are:
  - Maximum length = 1500 bytes
  - Minimum length for untagged MAC frames = 46 bytes
  - Minimum length for tagged MAC frames = 42 bytes

When the data field length is less than the minimum required, the PAD field is added to match the minimum length (42 bytes for tagged frames, 46 bytes for untagged frames).

- Frame check sequence: 4-byte field that contains the cyclic redundancy check (CRC) value. The CRC computation is based on the following fields: source address, destination address, QTag prefix, length/type, LLC data and PAD (that is, all fields except the preamble, SFD). The generating polynomial is the following:

$$G(x) = x^{32} + x^{26} + x^{23} + x^{22} + x^{16} + x^{12} + x^{11} + x^{10} + x^8 + x^7 + x^5 + x^4 + x^2 + x + 1$$

The CRC value of a frame is computed as follows:

- The first 2 bits of the frame are complemented
- The n-bits of the frame are the coefficients of a polynomial  $M(x)$  of degree  $(n - 1)$ . The first bit of the destination address corresponds to the  $x^{n-1}$  term and the last bit of the data field corresponds to the  $x^0$  term
- $M(x)$  is multiplied by  $x^{32}$  and divided by  $G(x)$ , producing a remainder  $R(x)$  of degree  $\leq 31$
- The coefficients of  $R(x)$  are considered as a 32-bit sequence
- The bit sequence is complemented and the result is the CRC
- The 32-bits of the CRC value are placed in the frame check sequence. The  $x^{32}$  term is the first transmitted, the  $x^0$  term is the last one

Figure 335. MAC frame format

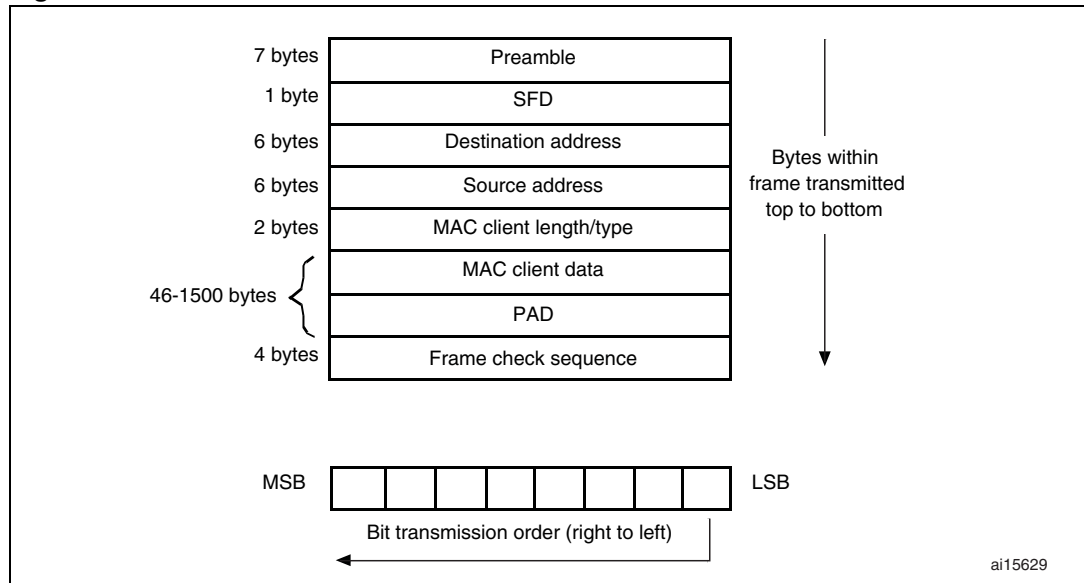
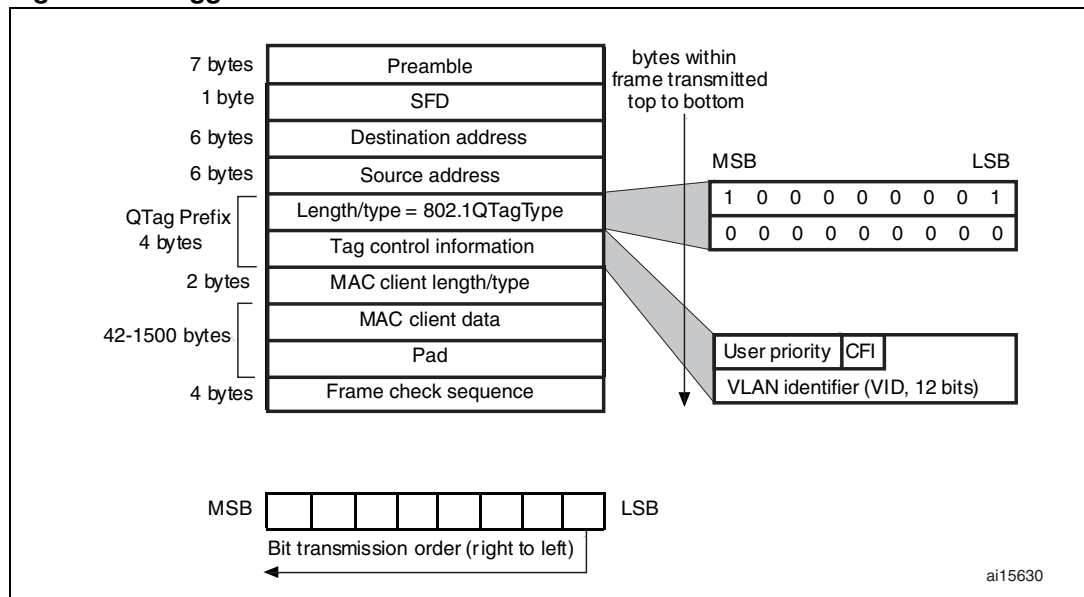


Figure 336. Tagged MAC frame format



Each byte of the MAC frame, except the FCS field, is transmitted low-order bit first.

An invalid MAC frame is defined by one of the following conditions:

- The frame length is inconsistent with the expected value as specified by the length/type field. If the length/type field contains a type value, then the frame length is assumed to be consistent with this field (no invalid frame)
- The frame length is not an integer number of bytes (extra bits)
- The CRC value computed on the incoming frame does not match the included FCS

## 28.5.2 MAC frame transmission

The DMA controls all transactions for the transmit path. Ethernet frames read from the system memory are pushed into the FIFO by the DMA. The frames are then popped out and transferred to the MAC core. When the end-of-frame is transferred, the status of the transmission is taken from the MAC core and transferred back to the DMA. The Transmit FIFO has a depth of 2 Kbyte. FIFO-fill level is indicated to the DMA so that it can initiate a data fetch in required bursts from the system memory, using the AHB interface. The data from the AHB Master interface is pushed into the FIFO.

When the SOF is detected, the MAC accepts the data and begins transmitting to the MII. The time required to transmit the frame data to the MII after the application initiates transmission is variable, depending on delay factors like IFG delay, time to transmit preamble/SFD, and any back-off delays for Half-duplex mode. After the EOF is transferred to the MAC core, the core completes normal transmission and then gives the status of transmission back to the DMA. If a normal collision (in Half-duplex mode) occurs during transmission, the MAC core makes the transmit status valid, then accepts and drops all further data until the next SOF is received. The same frame should be retransmitted from SOF on observing a Retry request (in the Status) from the MAC. The MAC issues an underflow status if the data are not provided continuously during the transmission. During the normal transfer of a frame, if the MAC receives an SOF without getting an EOF for the previous frame, then the SOF is ignored and the new frame is considered as the continuation of the previous frame.

There are two modes of operation for popping data towards the MAC core:

- In Threshold mode, as soon as the number of bytes in the FIFO crosses the configured threshold level (or when the end-of-frame is written before the threshold is crossed), the data is ready to be popped out and forwarded to the MAC core. The threshold level is configured using the TTC bits of ETH\_DMABMR.
- In Store-and-forward mode, only after a complete frame is stored in the FIFO, the frame is popped towards the MAC core. If the Tx FIFO size is smaller than the Ethernet frame to be transmitted, then the frame is popped towards the MAC core when the Tx FIFO becomes almost full.

The application can flush the Transmit FIFO of all contents by setting the FTF (ETH\_DMAOMR register [20]) bit. This bit is self-clearing and initializes the FIFO pointers to the default state. If the FTF bit is set during a frame transfer to the MAC core, then transfer is stopped as the FIFO is considered to be empty. Hence an underflow event occurs at the MAC transmitter and the corresponding Status word is forwarded to the DMA.

### Automatic CRC and pad generation

When the number of bytes received from the application falls below 60 (DA+SA+LT+Data), zeros are appended to the transmitting frame to make the data length exactly 46 bytes to meet the minimum data field requirement of IEEE 802.3. The MAC can be programmed not to append any padding. The cyclic redundancy check (CRC) for the frame check sequence (FCS) field is calculated and appended to the data being transmitted. When the MAC is programmed to not append the CRC value to the end of Ethernet frames, the computed CRC is not transmitted. An exception to this rule is that when the MAC is programmed to append pads for frames (DA+SA+LT+Data) less than 60 bytes, CRC will be appended at the end of the padded frames.



The CRC generator calculates the 32-bit CRC for the FCS field of the Ethernet frame. The encoding is defined by the following polynomial.

$$G(x) = x^{32} + x^{26} + x^{23} + x^{22} + x^{16} + x^{12} + x^{11} + x^{10} + x^8 + x^7 + x^5 + x^4 + x^2 + x + 1$$

### Transmit protocol

The MAC controls the operation of Ethernet frame transmission. It performs the following functions to meet the IEEE 802.3/802.3z specifications. It:

- generates the preamble and SFD
- generates the jam pattern in Half-duplex mode
- controls the Jabber timeout
- controls the flow for Half-duplex mode (back pressure)
- generates the transmit frame status
- contains time stamp snapshot logic in accordance with IEEE 1588

When a new frame transmission is requested, the MAC sends out the preamble and SFD, followed by the data. The preamble is defined as 7 bytes of 0b10101010 pattern, and the SFD is defined as 1 byte of 0b10101011 pattern. The collision window is defined as 1 slot time (512 bit times for 10/100 Mbit/s Ethernet). The jam pattern generation is applicable only to Half-duplex mode, not to Full-duplex mode.

In MII mode, if a collision occurs at any time from the beginning of the frame to the end of the CRC field, the MAC sends a 32-bit jam pattern of 0x5555 5555 on the MII to inform all other stations that a collision has occurred. If the collision is seen during the preamble transmission phase, the MAC completes the transmission of the preamble and SFD and then sends the jam pattern.

A jabber timer is maintained to cut off the transmission of Ethernet frames if more than 2048 (default) bytes have to be transferred. The MAC uses the deferral mechanism for flow control (back pressure) in Half-duplex mode. When the application requests to stop receiving frames, the MAC sends a JAM pattern of 32 bytes whenever it senses the reception of a frame, provided that transmit flow control is enabled. This results in a collision and the remote station backs off. The application requests flow control by setting the BPA bit (bit 0) in the ETH\_MACFCR register. If the application requests a frame to be transmitted, then it is scheduled and transmitted even when back pressure is activated. Note that if back pressure is kept activated for a long time (and more than 16 consecutive collision events occur) then the remote stations abort their transmissions due to excessive collisions. If IEEE 1588 time stamping is enabled for the transmit frame, this block takes a snapshot of the system time when the SFD is put onto the transmit MII bus.

### Transmit scheduler

The MAC is responsible for scheduling the frame transmission on the MII. It maintains the interframe gap between two transmitted frames and follows the truncated binary exponential backoff algorithm for Half-duplex mode. The MAC enables transmission after satisfying the IFG and backoff delays. It maintains an idle period of the configured interframe gap (IFG bits in the ETH\_MACCCR register) between any two transmitted frames. If frames to be transmitted arrive sooner than the configured IFG time, the MII waits for the enable signal from the MAC before starting the transmission on it. The MAC starts its IFG counter as soon as the carrier signal of the MII goes inactive. At the end of the programmed IFG value, the MAC enables transmission in Full-duplex mode. In Half-duplex mode and when IFG is

configured for 96 bit times, the MAC follows the rule of deference specified in Section 4.2.3.2.1 of the IEEE 802.3 specification. The MAC resets its IFG counter if a carrier is detected during the first two-thirds (64-bit times for all IFG values) of the IFG interval. If the carrier is detected during the final one third of the IFG interval, the MAC continues the IFG count and enables the transmitter after the IFG interval. The MAC implements the truncated binary exponential backoff algorithm when it operates in Half-duplex mode.

### Transmit flow control

When the Transmit Flow Control Enable bit (TFE bit in ETH\_MACFCR) is set, the MAC generates Pause frames and transmits them as necessary, in Full-duplex mode. The Pause frame is appended with the calculated CRC, and is sent. Pause frame generation can be initiated in two ways.

A pause frame is sent either when the application sets the FCB bit in the ETH\_MACFCR register or when the receive FIFO is full (packet buffer).

- If the application has requested flow control by setting the FCB bit in ETH\_MACFCR, the MAC generates and transmits a single Pause frame. The value of the pause time in the generated frame contains the programmed pause time value in ETH\_MACFCR. To extend the pause or end the pause prior to the time specified in the previously transmitted Pause frame, the application must request another Pause frame transmission after programming the Pause Time value (PT in ETH\_MACFCR register) with the appropriate value.
- If the application has requested flow control when the receive FIFO is full, the MAC generates and transmits a Pause frame. The value of the pause time in the generated frame is the programmed pause time value in ETH\_MACFCR. If the receive FIFO remains full at a configurable number of slot-times (PLT bits in ETH\_MACFCR) before this Pause time runs out, a second Pause frame is transmitted. The process is repeated as long as the receive FIFO remains full. If this condition is no more satisfied prior to the sampling time, the MAC transmits a Pause frame with zero pause time to indicate to the remote end that the receive buffer is ready to receive new data frames.

### Single-packet transmit operation

The general sequence of events for a transmit operation is as follows:

1. If the system has data to be transferred, the DMA controller fetches them from the memory through the AHB Master interface and starts forwarding them to the FIFO. It continues to receive the data until the end of frame is transferred.
2. When the threshold level is crossed or a full packet of data is received into the FIFO, the frame data are popped and driven to the MAC core. The DMA continues to transfer data from the FIFO until a complete packet has been transferred to the MAC. Upon completion of the frame, the DMA controller is notified by the status coming from the MAC.

### Transmit operation—Two packets in the buffer

1. Because the DMA must update the descriptor status before releasing it to the Host, there can be at the most two frames inside a transmit FIFO. The second frame is fetched by the DMA and put into the FIFO only if the OSF (operate on second frame) bit is set. If this bit is not set, the next frame is fetched from the memory only after the MAC has completely processed the frame and the DMA has released the descriptors.
2. If the OSF bit is set, the DMA starts fetching the second frame immediately after completing the transfer of the first frame to the FIFO. It does not wait for the status to be updated. In the meantime, the second frame is received into the FIFO while the first

frame is being transmitted. As soon as the first frame has been transferred and the status is received from the MAC, it is pushed to the DMA. If the DMA has already completed sending the second packet to the FIFO, the second transmission must wait for the status of the first packet before proceeding to the next frame.

### Retransmission during collision

While a frame is being transferred to the MAC, a collision event may occur on the MAC line interface in Half-duplex mode. The MAC would then indicate a retry attempt by giving the status even before the end of frame is received. Then the retransmission is enabled and the frame is popped out again from the FIFO. After more than 96 bytes have been popped towards the MAC core, the FIFO controller frees up that space and makes it available to the DMA to push in more data. This means that the retransmission is not possible after this threshold is crossed or when the MAC core indicates a late collision event.

### Transmit FIFO flush operation

The MAC provides a control to the software to flush the Transmit FIFO through the use of Bit 20 in the Operation mode register. The Flush operation is immediate and the Tx FIFO and the corresponding pointers are cleared to the initial state even if the Tx FIFO is in the middle of transferring a frame to the MAC Core. This results in an underflow event in the MAC transmitter, and the frame transmission is aborted. The status of such a frame is marked with both underflow and frame flush events (TDES0 bits 13 and 1). No data are coming to the FIFO from the application (DMA) during the Flush operation. Transfer transmit status words are transferred to the application for the number of frames that is flushed (including partial frames). Frames that are completely flushed have the Frame flush status bit (TDES0 13) set. The Flush operation is completed when the application (DMA) has accepted all of the Status words for the frames that were flushed. The Transmit FIFO Flush control register bit is then cleared. At this point, new frames from the application (DMA) are accepted. All data presented for transmission after a Flush operation are discarded unless they start with an SOF marker.

### Transmit status word

At the end of the Ethernet frame transfer to the MAC core and after the core has completed the transmission of the frame, the transmit status is given to the application. The detailed description of the Transmit Status is the same as for bits [23:0] in TDES0. If IEEE 1588 time stamping is enabled, a specific frames' 64-bit time stamp is returned, along with the transmit status.

### Transmit checksum offload

Communication protocols such as TCP and UDP implement checksum fields, which helps determine the integrity of data transmitted over a network. Because the most widespread use of Ethernet is to encapsulate TCP and UDP over IP datagrams, the Ethernet controller has a transmit checksum offload feature that supports checksum calculation and insertion in the transmit path, and error detection in the receive path. This section explains the operation of the checksum offload feature for transmitted frames.

*Note: 1 The checksum for TCP, UDP or ICMP is calculated over a complete frame, then inserted into its corresponding header field. Due to this requirement, this function is enabled only when the Transmit FIFO is configured for Store-and-forward mode (that is, when the TSF bit is set in the ETH\_ETH\_DMAOMR register). If the core is configured for Threshold (cut-through) mode, the Transmit checksum offload is bypassed.*

- 2 You must make sure the Transmit FIFO is deep enough to store a complete frame before that frame is transferred to the MAC Core transmitter. If the FIFO depth is less than the input Ethernet frame size, the payload (TCP/UDP/ICMP) checksum insertion function is bypassed and only the frame's IPv4 Header checksum is modified, even in Store-and-forward mode.

The transmit checksum offload supports two types of checksum calculation and insertion. This checksum can be controlled for each frame by setting the CIC bits (Bits 28:27 in TDES1, described in [TDES1: Transmit descriptor Word1 on page 964](#)).

See IETF specifications RFC 791, RFC 793, RFC 768, RFC 792, RFC 2460 and RFC 4443 for IPv4, TCP, UDP, ICMP, IPv6 and ICMPv6 packet header specifications, respectively.

- IP header checksum

In IPv4 datagrams, the integrity of the header fields is indicated by the 16-bit header checksum field (the eleventh and twelfth bytes of the IPv4 datagram). The checksum offload detects an IPv4 datagram when the Ethernet frame's Type field has the value 0x0800 and the IP datagram's Version field has the value 0x4. The input frame's checksum field is ignored during calculation and replaced by the calculated value. IPv6 headers do not have a checksum field; thus, the checksum offload does not modify IPv6 header fields. The result of this IP header checksum calculation is indicated by the IP Header Error status bit in the Transmit status (Bit 16). This status bit is set whenever the values of the Ethernet Type field and the IP header's Version field are not consistent, or when the Ethernet frame does not have enough data, as indicated by the IP header Length field. In other words, this bit is set when an IP header error is asserted under the following circumstances:

- a) For IPv4 datagrams:

- The received Ethernet type is 0x0800, but the IP header's Version field does not equal 0x4
- The IPv4 Header Length field indicates a value less than 0x5 (20 bytes)
- The total frame length is less than the value given in the IPv4 Header Length field

- b) For IPv6 datagrams:

- The Ethernet type is 0x86DD but the IP header Version field does not equal 0x6
- The frame ends before the IPv6 header (40 bytes) or extension header (as given in the corresponding Header Length field in an extension header) has been completely received. Even when the checksum offload detects such an IP header error, it inserts an IPv4 header checksum if the Ethernet Type field indicates an IPv4 payload.

- TCP/UDP/ICMP checksum

The TCP/UDP/ICMP checksum processes the IPv4 or IPv6 header (including extension headers) and determines whether the encapsulated payload is TCP, UDP or ICMP.

Note that:

- a) For non-TCP, -UDP, or -ICMP/ICMPv6 payloads, this checksum is bypassed and nothing further is modified in the frame.
- b) Fragmented IP frames (IPv4 or IPv6), IP frames with security features (such as an authentication header or encapsulated security payload), and IPv6 frames with routing headers are bypassed and not processed by the checksum.

The checksum is calculated for the TCP, UDP, or ICMP payload and inserted into its corresponding field in the header. It can work in the following two modes:

- In the first mode, the TCP, UDP, or ICMPv6 pseudo-header is not included in the checksum calculation and is assumed to be present in the input frame's checksum field. The checksum field is included in the checksum calculation, and then replaced by the final calculated checksum.
- In the second mode, the checksum field is ignored, the TCP, UDP, or ICMPv6 pseudo-header data are included into the checksum calculation, and the checksum field is overwritten with the final calculated value.

Note that: for ICMP-over-IPv4 packets, the checksum field in the ICMP packet must always be 0x0000 in both modes, because pseudo-headers are not defined for such packets. If it does not equal 0x0000, an incorrect checksum may be inserted into the packet.

The result of this operation is indicated by the payload checksum error status bit in the Transmit Status vector (bit 12). The payload checksum error status bit is set when either of the following is detected:

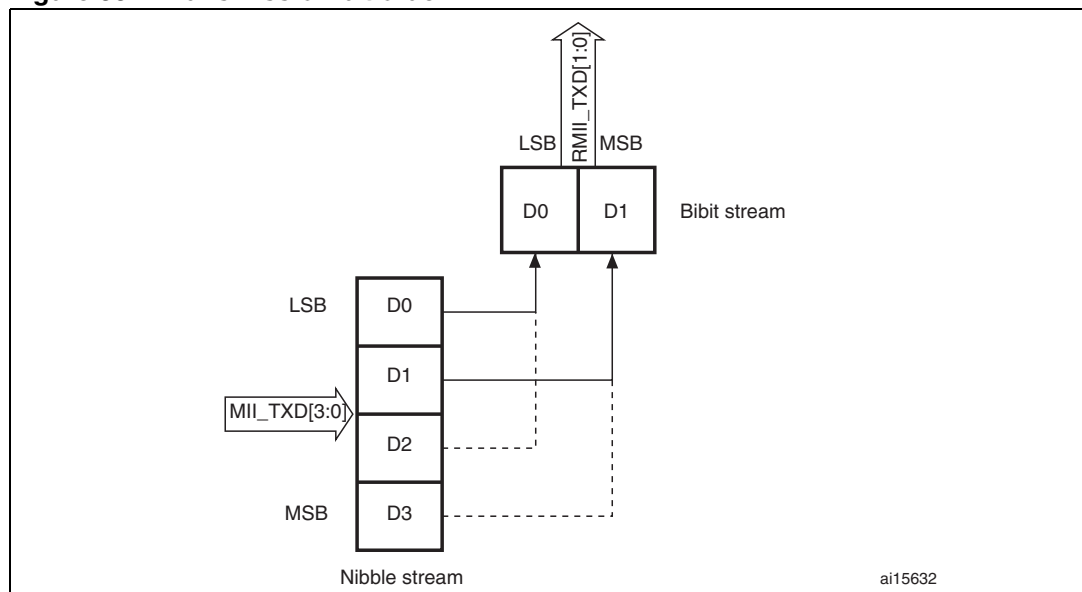
- the frame has been forwarded to the MAC transmitter in Store-and-forward mode without the end of frame being written to the FIFO
- the packet ends before the number of bytes indicated by the payload length field in the IP header is received.

When the packet is longer than the indicated payload length, the bytes are ignored as stuff bytes, and no error is reported. When the first type of error is detected, the TCP, UDP or ICMP header is not modified. For the second error type, still, the calculated checksum is inserted into the corresponding header field.

**MII/RMII transmit bit order**

Each nibble from the MII is transmitted on the RMII a dibit at a time with the order of dibit transmission shown in *Figure 337*. Lower order bits (D1 and D0) are transmitted first followed by higher order bits (D2 and D3).

**Figure 337. Transmission bit order**



MII/RMII transmit timing diagrams

Figure 338. Transmission with no collision

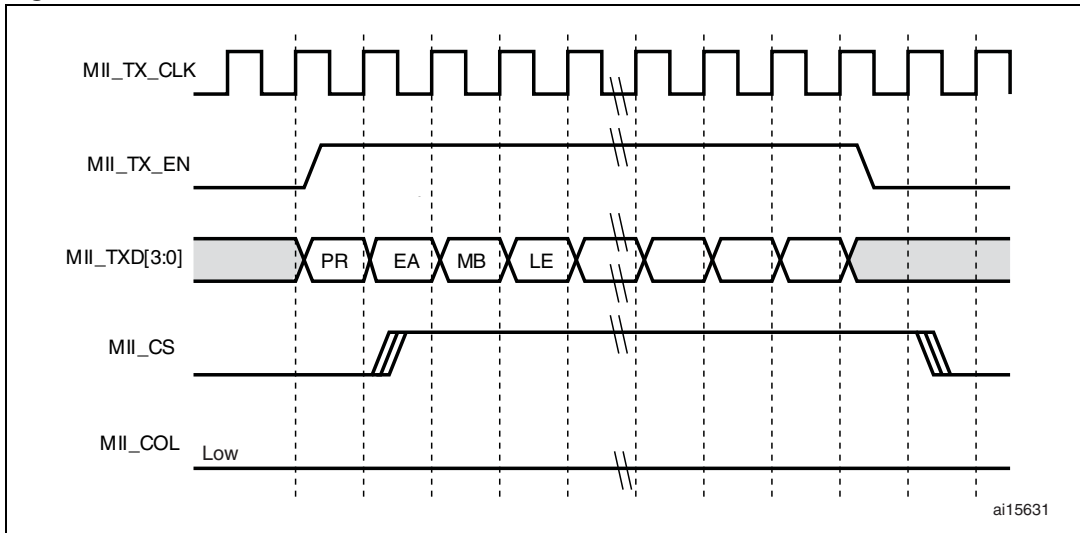


Figure 339. Transmission with collision

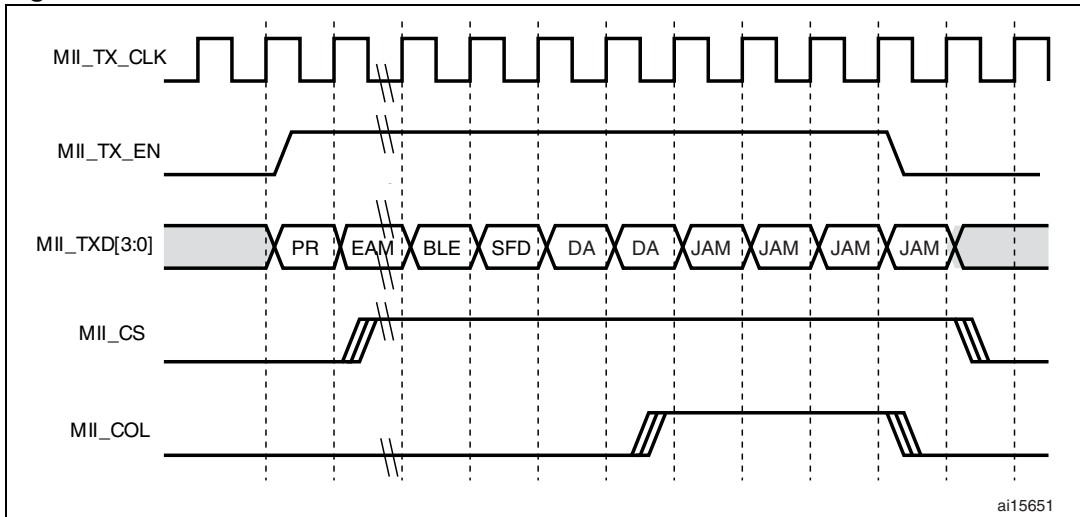
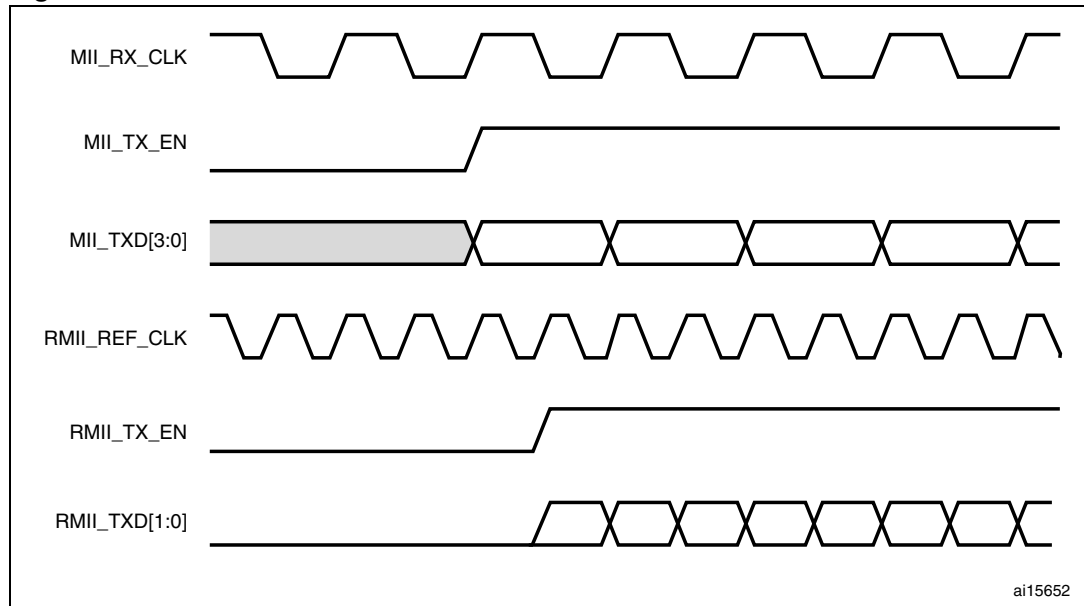


Figure 340 shows a frame transmission in MII and RMII.

**Figure 340. Frame transmission in MMI and RMII modes**



### 28.5.3 MAC frame reception

The MAC received frames are pushed into the Rx FIFO. The status (fill level) of this FIFO is indicated to the DMA once it crosses the configured receive threshold (RTC in the ETH\_DMAOMR register) so that the DMA can initiate pre-configured burst transfers towards the AHB interface.

In the default Cut-through mode, when 64 bytes (configured with the RTC bits in the ETH\_DMAOMR register) or a full packet of data are received into the FIFO, the data are popped out and the DMA is notified of its availability. Once the DMA has initiated the transfer to the AHB interface, the data transfer continues from the FIFO until a complete packet has been transferred. Upon completion of the EOF frame transfer, the status word is popped out and sent to the DMA controller.

In Rx FIFO Store-and-forward mode (configured by the RSF bit in the ETH\_DMAOMR register), a frame is read out only after being written completely into the Receive FIFO. In this mode, all error frames are dropped (if the core is configured to do so) such that only valid frames are read out and forwarded to the application. In Cut-through mode, some error frames are not dropped, because the error status is received at the end of the frame, by which time the start of that frame has already been read out of the FIFO.

A receive operation is initiated when the MAC detects an SFD on the MII. The core strips the preamble and SFD before proceeding to process the frame. The header fields are checked for the filtering and the FCS field used to verify the CRC for the frame. The frame is dropped in the core if it fails the address filter.

#### Receive protocol

The received frame preamble and SFD are stripped. Once the SFD has been detected, the MAC starts sending the Ethernet frame data to the receive FIFO, beginning with the first byte following the SFD (destination address). If IEEE 1588 time stamping is enabled, a snapshot of the system time is taken when any frame's SFD is detected on the MII. Unless the MAC filters out and drops the frame, this time stamp is passed on to the application.

If the received frame length/type field is less than 0x600 and if the MAC is programmed for the auto CRC/pad stripping option, the MAC sends the data of the frame to Rx FIFO up to the count specified in the length/type field, then starts dropping bytes (including the FCS field). If the Length/Type field is greater than or equal to 0x600, the MAC sends all received Ethernet frame data to Rx FIFO, regardless of the value on the programmed auto-CRC strip option. The MAC watchdog timer is enabled by default, that is, frames above 2048 bytes (DA + SA + LT + Data + pad + FCS) are cut off. This feature can be disabled by programming the watchdog disable (WD) bit in the MAC configuration register. However, even if the watchdog timer is disabled, frames greater than 16 KB in size are cut off and a watchdog timeout status is given.

### Receive CRC: automatic CRC and pad stripping

The MAC checks for any CRC error in the receiving frame. It calculates the 32-bit CRC for the received frame that includes the Destination address field through the FCS field. The encoding is defined by the following polynomial.

$$G(x) = x^{32} + x^{26} + x^{23} + x^{22} + x^{16} + x^{12} + x^{11} + x^{10} + x^8 + x^7 + x^5 + x^4 + x^2 + x + 1$$

Regardless of the auto-pad/CRC strip, the MAC receives the entire frame to compute the CRC check for the received frame.

### Receive checksum offload

Both IPv4 and IPv6 frames in the received Ethernet frames are detected and processed for data integrity. You can enable the receive checksum offload by setting the IPCO bit in the ETH\_MACCR register. The MAC receiver identifies IPv4 or IPv6 frames by checking for value 0x0800 or 0x86DD, respectively, in the received Ethernet frame Type field. This identification applies to VLAN-tagged frames as well. The receive checksum offload calculates IPv4 header checksums and checks that they match the received IPv4 header checksums. The IP Header Error bit is set for any mismatch between the indicated payload type (Ethernet Type field) and the IP header version, or when the received frame does not have enough bytes, as indicated by the IPv4 header's Length field (or when fewer than 20 bytes are available in an IPv4 or IPv6 header). The receive checksum offload also identifies a TCP, UDP or ICMP payload in the received IP datagrams (IPv4 or IPv6) and calculates the checksum of such payloads properly, as defined in the TCP, UDP or ICMP specifications. It includes the TCP/UDP/ICMPv6 pseudo-header bytes for checksum calculation and checks whether the received checksum field matches the calculated value. The result of this operation is given as a Payload Checksum Error bit in the receive status word. This status bit is also set if the length of the TCP, UDP or ICMP payload does not match the expected payload length given in the IP header. As mentioned in [TCP/UDP/ICMP checksum on page 932](#), the receive checksum offload bypasses the payload of fragmented IP datagrams, IP datagrams with security features, IPv6 routing headers, and payloads other than TCP, UDP or ICMP. This information (whether the checksum is bypassed or not) is given in the receive status, as described in the [RDES0: Receive descriptor Word0](#) section. In this configuration, the core does not append any payload checksum bytes to the received Ethernet frames.

As mentioned in [RDES0: Receive descriptor Word0 on page 973](#), the meaning of certain register bits changes as shown in [Table 208](#).



Table 208. Frame statuses

Bit 18: Ethernet frame	Bit 27: Header checksum error	Bit 28: Payload checksum error	Frame status
0	0	0	The frame is an IEEE 802.3 frame (Length field value is less than 0x0600).
1	0	0	IPv4/IPv6 Type frame in which no checksum error is detected.
1	0	1	IPv4/IPv6 Type frame in which a payload checksum error (as described for PCE) is detected
1	1	0	IPv4/IPv6 Type frame in which IP header checksum error (as described for IPCO HCE) is detected.
1	1	1	IPv4/IPv6 Type frame in which both PCE and IPCO HCE are detected.
0	0	1	IPv4/IPv6 Type frame in which there is no IP HCE and the payload check is bypassed due to unsupported payload.
0	1	1	Type frame which is neither IPv4 or IPv6 (checksum offload bypasses the checksum check completely)
0	1	0	Reserved

### Receive frame controller

If the RA bit is reset in the MAC CSR frame filter register, the MAC performs frame filtering based on the destination/source address (the application still needs to perform another level of filtering if it decides not to receive any bad frames like runt, CRC error frames, etc.). On detecting a filter-fail, the frame is dropped and not transferred to the application. When the filtering parameters are changed dynamically, and in case of (DA-SA) filter-fail, the rest of the frame is dropped and the Rx Status Word is immediately updated (with zero frame length, CRC error and Runt Error bits set), indicating the filter fail. In Ethernet power down mode, all received frames are dropped, and are not forwarded to the application.

### Receive flow control

The MAC detects the receiving Pause frame and pauses the frame transmission for the delay specified within the received Pause frame (only in Full-duplex mode). The Pause frame detection function can be enabled or disabled with the RFCE bit in ETH\_MACFCR. Once receive flow control has been enabled, the received frame destination address begins to be monitored for any match with the multicast address of the control frame (0x0180 C200 0001). If a match is detected (the destination address of the received frame matches the reserved control frame destination address), the MAC then decides whether or not to transfer the received control frame to the application, based on the level of the PCF bit in ETH\_MACFFR.

The MAC also decodes the type, opcode, and Pause Timer fields of the receiving control frame. If the byte count of the status indicates 64 bytes, and if there is no CRC error, the MAC transmitter pauses the transmission of any data frame for the duration of the decoded Pause time value, multiplied by the slot time (64 byte times for both 10/100 Mbit/s modes).

Meanwhile, if another Pause frame is detected with a zero Pause time value, the MAC resets the Pause time and manages this new pause request.

If the received control frame matches neither the type field (0x8808), the opcode (0x00001), nor the byte length (64 bytes), or if there is a CRC error, the MAC does not generate a Pause.

In the case of a pause frame with a multicast destination address, the MAC filters the frame based on the address match.

For a pause frame with a unicast destination address, the MAC filtering depends on whether the DA matched the contents of the MAC address 0 register and whether the UPDF bit in ETH\_MACFCR is set (detecting a pause frame even with a unicast destination address). The PCF register bits (bits [7:6] in ETH\_MACFFR) control filtering for control frames in addition to address filtering.

### Receive operation multiframe handling

Since the status is available immediately following the data, the FIFO is capable of storing any number of frames into it, as long as it is not full.

### Error handling

If the Rx FIFO is full before it receives the EOF data from the MAC, an overflow is declared and the whole frame is dropped, and the overflow counter in the (ETH\_DMAMFBOCR register) is incremented. The status indicates a partial frame due to overflow. The Rx FIFO can filter error and undersized frames, if enabled (using the FEF and FUGF bits in ETH\_DMAOMR).

If the Receive FIFO is configured to operate in Store-and-forward mode, all error frames can be filtered and dropped.

In Cut-through mode, if a frame's status and length are available when that frame's SOF is read from the Rx FIFO, then the complete erroneous frame can be dropped. The DMA can flush the error frame being read from the FIFO, by enabling the receive frame flash bit. The data transfer to the application (DMA) is then stopped and the rest of the frame is internally read and dropped. The next frame transfer can then be started, if available.

### Receive status word

At the end of the Ethernet frame reception, the MAC outputs the receive status to the application (DMA). The detailed description of the receive status is the same as for bits[31:0] in RDES0, given in [RDES0: Receive descriptor Word0 on page 973](#).

### Frame length interface

In case of switch applications, data transmission and reception between the application and MAC happen as complete frame transfers. The application layer should be aware of the length of the frames received from the ingress port in order to transfer the frame to the egress port. The MAC core provides the frame length of each received frame inside the status at the end of each frame reception.

*Note:* A frame length value of 0 is given for partial frames written into the Rx FIFO due to overflow.

### MII/RMII receive bit order

Each nibble is transmitted to the MII from the dibit received from the RMII in the nibble transmission order shown in [Figure 341](#). The lower-order bits (D0 and D1) are received first, followed by the higher-order bits (D2 and D3).

Figure 341. Receive bit order

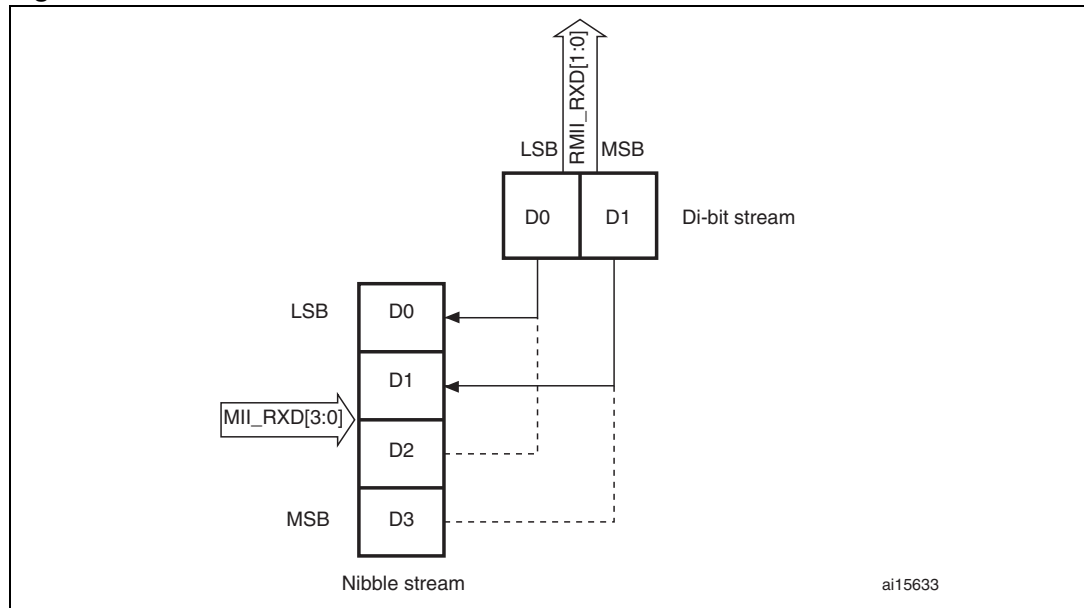


Figure 342. Reception with no error

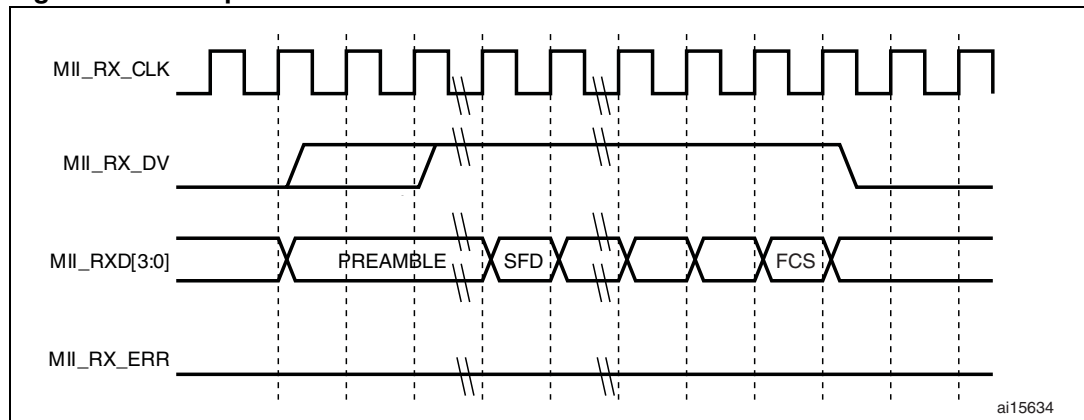


Figure 343. Reception with errors

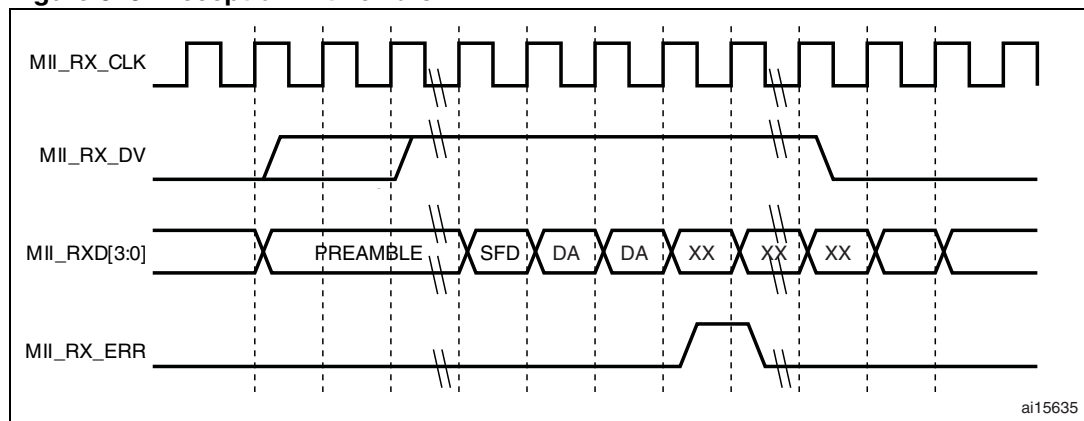
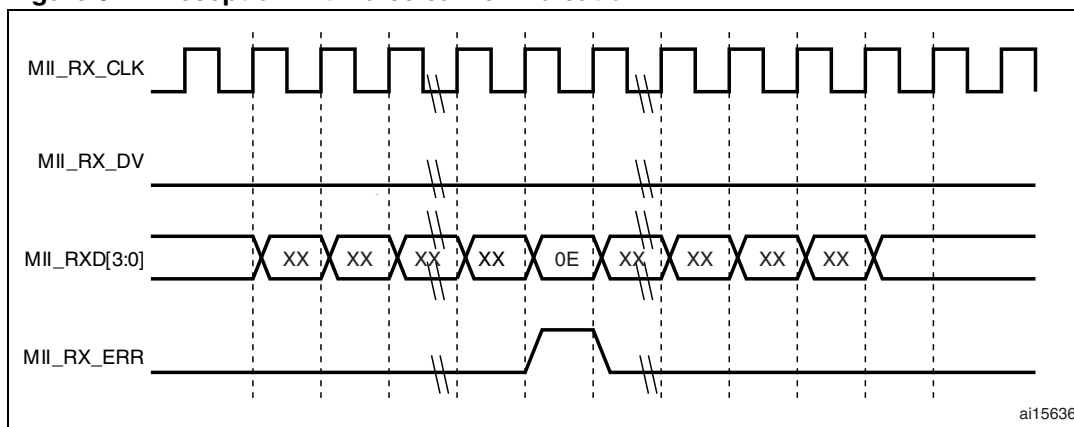


Figure 344. Reception with false carrier indication



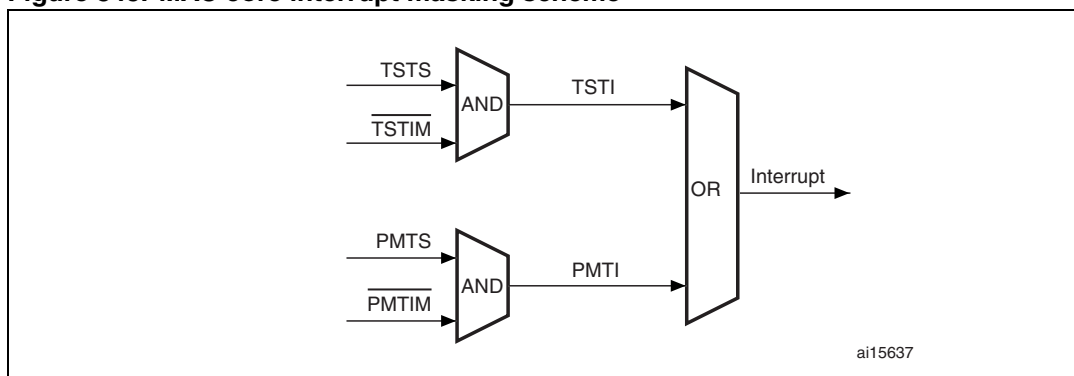
### 28.5.4 MAC interrupts

Interrupts can be generated from the MAC core as a result of various events.

The ETH\_MACSR register describes the events that can cause an interrupt from the MAC core. You can prevent each event from asserting the interrupt by setting the corresponding mask bits in the Interrupt Mask register.

The interrupt register bits only indicate the block from which the event is reported. You have to read the corresponding status registers and other registers to clear the interrupt. For example, bit 3 of the Interrupt register, set high, indicates that the Magic packet or Wake-on-LAN frame is received in Power-down mode. You must read the ETH\_MACPMTCSR Register to clear this interrupt event.

Figure 345. MAC core interrupt masking scheme



### 28.5.5 MAC filtering

#### Address filtering

Address filtering checks the destination and source addresses on all received frames and the address filtering status is reported accordingly. Address checking is based on different parameters (Frame filter register) chosen by the application. The filtered frame can also be identified: multicast or broadcast frame.

Address filtering uses the station's physical (MAC) address and the Multicast Hash table for address checking purposes.

### Unicast destination address filter

The MAC supports up to 4 MAC addresses for unicast perfect filtering. If perfect filtering is selected (HU bit in the Frame filter register is reset), the MAC compares all 48 bits of the received unicast address with the programmed MAC address for any match. Default MacAddr0 is always enabled, other addresses MacAddr1–MacAddr3 are selected with an individual enable bit. Each byte of these other addresses (MacAddr1–MacAddr3) can be masked during comparison with the corresponding received DA byte by setting the corresponding Mask Byte Control bit in the register. This helps group address filtering for the DA. In Hash filtering mode (when HU bit is set), the MAC performs imperfect filtering for unicast addresses using a 64-bit Hash table. For hash filtering, the MAC uses the 6 upper CRC (see note 1 below) bits of the received destination address to index the content of the Hash table. A value of 000000 selects bit 0 in the selected register, and a value of 111111 selects bit 63 in the Hash Table register. If the corresponding bit (indicated by the 6-bit CRC) is set to 1, the unicast frame is said to have passed the Hash filter; otherwise, the frame has failed the Hash filter.

**Note:** 1 *This CRC is a 32-bit value coded by the following polynomial (for more details refer to [Section 28.5.3: MAC frame reception](#)):*

$$G(x) = x^{32} + x^{26} + x^{23} + x^{22} + x^{16} + x^{12} + x^{11} + x^{10} + x^8 + x^7 + x^5 + x^4 + x^2 + x + 1$$

### Multicast destination address filter

The MAC can be programmed to pass all multicast frames by setting the PAM bit in the Frame filter register. If the PAM bit is reset, the MAC performs the filtering for multicast addresses based on the HM bit in the Frame filter register. In Perfect filtering mode, the multicast address is compared with the programmed MAC destination address registers (1–3). Group address filtering is also supported. In Hash filtering mode, the MAC performs imperfect filtering using a 64-bit Hash table. For hash filtering, the MAC uses the 6 upper CRC (see note 1 below) bits of the received multicast address to index the content of the Hash table. A value of 000000 selects bit 0 in the selected register and a value of 111111 selects bit 63 in the Hash Table register. If the corresponding bit is set to 1, then the multicast frame is said to have passed the Hash filter; otherwise, the frame has failed the Hash filter.

**Note:** 1 *This CRC is a 32-bit value coded by the following polynomial (for more details refer to [Section 28.5.3: MAC frame reception](#)):*

$$G(x) = x^{32} + x^{26} + x^{23} + x^{22} + x^{16} + x^{12} + x^{11} + x^{10} + x^8 + x^7 + x^5 + x^4 + x^2 + x + 1$$

### Hash or perfect address filter

The DA filter can be configured to pass a frame when its DA matches either the Hash filter or the Perfect filter by setting the HPF bit in the Frame filter register and setting the corresponding HU or HM bits. This configuration applies to both unicast and multicast frames. If the HPF bit is reset, only one of the filters (Hash or Perfect) is applied to the received frame.

### Broadcast address filter

The MAC does not filter any broadcast frames in the default mode. However, if the MAC is programmed to reject all broadcast frames by setting the BFD bit in the Frame filter register, any broadcast frames are dropped.

### Unicast source address filter

The MAC can also perform perfect filtering based on the source address field of the received frames. By default, the MAC compares the SA field with the values programmed in the SA registers. The MAC address registers [1:3] can be configured to contain SA instead of DA for comparison, by setting bit 30 in the corresponding register. Group filtering with SA is also supported. The frames that fail the SA filter are dropped by the MAC if the SAF bit in the Frame filter register is set. Otherwise, the result of the SA filter is given as a status bit in the Receive Status word (see [RDES0: Receive descriptor Word0](#)).

When the SAF bit is set, the result of the SA and DA filters is AND'ed to decide whether the frame needs to be forwarded. This means that either of the filter fail result will drop the frame. Both filters have to pass the frame for the frame to be forwarded to the application.

### Inverse filtering operation

For both destination and source address filtering, there is an option to invert the filter-match result at the final output. These are controlled by the DAIF and SAIF bits in the Frame filter register, respectively. The DAIF bit is applicable for both Unicast and Multicast DA frames. The result of the unicast/multicast destination address filter is inverted in this mode. Similarly, when the SAIF bit is set, the result of the unicast SA filter is inverted. [Table 209](#) and [Table 210](#) summarize destination and source address filtering based on the type of frame received.

**Table 209. Destination address filtering table**

Frame type	PM	HPF	HU	DAIF	HM	PAM	DB	DA filter operation
Broadcast	1	X	X	X	X	X	X	Pass
	0	X	X	X	X	X	0	Pass
	0	X	X	X	X	X	1	Fail
Unicast	1	X	X	X	X	X	X	Pass all frames
	0	X	0	0	X	X	X	Pass on perfect/group filter match
	0	X	0	1	X	X	X	Fail on perfect/Group filter match
	0	0	1	0	X	X	X	Pass on hash filter match
	0	0	1	1	X	X	X	Fail on hash filter match
	0	1	1	0	X	X	X	Pass on hash or perfect/Group filter match
	0	1	1	1	X	X	X	Fail on hash or perfect/Group filter match

**Table 209. Destination address filtering table (continued)**

Frame type	PM	HPF	HU	DAIF	HM	PAM	DB	DA filter operation
Multicast	1	X	X	X	X	X	X	Pass all frames
	X	X	X	X	X	1	X	Pass all frames
	0	X	X	0	0	0	X	Pass on Perfect/Group filter match and drop PAUSE control frames if PCF = 0x
	0	0	X	0	1	0	X	Pass on hash filter match and drop PAUSE control frames if PCF = 0x
	0	1	X	0	1	0	X	Pass on hash or perfect/Group filter match and drop PAUSE control frames if PCF = 0x
	0	X	X	1	0	0	X	Fail on perfect/Group filter match and drop PAUSE control frames if PCF = 0x
	0	0	X	1	1	0	X	Fail on hash filter match and drop PAUSE control frames if PCF = 0x
	0	1	X	1	1	0	X	Fail on hash or perfect/Group filter match and drop PAUSE control frames if PCF = 0x

**Table 210. Source address filtering table**

Frame type	RTP R	SAIF	SAF	SA filter operation
Unicast	1	X	X	Pass all frames
	0	0	0	Pass status on perfect/Group filter match but do not drop frames that fail
	0	1	0	Fail status on perfect/group filter match but do not drop frame
	0	0	1	Pass on perfect/group filter match and drop frames that fail
	0	1	1	Fail on perfect/group filter match and drop frames that fail

**28.5.6 MAC loopback mode**

The MAC supports loopback of transmitted frames onto its receiver. By default, the MAC loopback function is disabled, but this feature can be enabled by programming the Loopback bit in the MAC ETH\_MACCR register.

**28.5.7 MAC management counters: MMC**

The MAC management counters (MMC) maintain a set of registers for gathering statistics on the received and transmitted frames. These include a control register for controlling the behavior of the registers, two 32-bit registers containing generated interrupts (receive and transmit), and two 32-bit registers containing masks for the Interrupt register (receive and transmit). These registers are accessible from the application. Each register is 32 bits wide.

[Section 28.8: Ethernet register descriptions](#) describes the various counters and lists the addresses of each of the statistics counters. This address is used for read/write accesses to the desired transmit/receive counter.

The Receive MMC counters are updated for frames that pass address filtering. Dropped frames statistics are not updated unless the dropped frames are runt frames of less than 6 bytes (DA bytes are not received fully).

### Good transmitted and received frames

Transmitted frames are considered “good” if transmitted successfully. In other words, a transmitted frame is good if the frame transmission is not aborted due to any of the following errors:

- + Jabber Timeout
- + No Carrier/Loss of Carrier
- + Late Collision
- + Frame Underflow
- + Excessive Deferral
- + Excessive Collision

Received frames are considered “good” if none of the following errors exists:

- + CRC error
- + Runt Frame (shorter than 64 bytes)
- + Alignment error (in 10/ 100 Mbit/s only)
- + Length error (non-Type frames only)
- + Out of Range (non-Type frames only, longer than maximum size)
- + MII\_RXER Input error

The maximum frame size depends on the frame type, as follows:

- + Untagged frame maxsize = 1518
- + VLAN Frame maxsize = 1522

## 28.5.8 Power management: PMT

This section describes the power management (PMT) mechanisms supported by the MAC. PMT supports the reception of network (remote) wakeup frames and Magic Packet frames. PMT generates interrupts for wakeup frames and Magic Packets received by the MAC. The PMT block is enabled with remote wakeup frame enable and Magic Packet enable. These enable bits (WFE and MPE) are in the ETH\_MACPMTCSR register and are programmed by the application. When the power down mode is enabled in the PMT, then all received frames are dropped by the MAC and they are not forwarded to the application. The MAC comes out of the power down mode only when either a Magic Packet or a Remote wakeup frame is received and the corresponding detection is enabled.

### Remote wakeup frame filter register

There are eight wakeup frame filter registers. To write on each of them, load the wakeup frame filter register value by value. The wanted values of the wakeup frame filter are loaded by sequentially loading eight times the wakeup frame filter register. The read operation is identical to the write operation. To read the eight values, you have to read eight times the



wakeup frame filter register to reach the last register. Each read/write points the wakeup frame filter register to the next filter register.

**Figure 346. Wakeup frame filter register**

Wakeup frame filter reg0	Filter 0 Byte Mask							
Wakeup frame filter reg1	Filter 1 Byte Mask							
Wakeup frame filter reg2	Filter 2 Byte Mask							
Wakeup frame filter reg3	Filter 3 Byte Mask							
Wakeup frame filter reg4	RSVD	Filter 3 Command	RSVD	Filter 2 Command	RSVD	Filter 1 Command	RSVD	Filter 0 Command
Wakeup frame filter reg5	Filter 3 Offset		Filter 2 Offset		Filter 1 Offset		Filter 0 Offset	
Wakeup frame filter reg6	Filter 1 CRC - 16				Filter 0 CRC - 16			
Wakeup frame filter reg7	Filter 3 CRC - 16				Filter 2 CRC - 16			

ai15647

- **Filter i Byte Mask**  
 This register defines which bytes of the frame are examined by filter i (0, 1, 2, and 3) in order to determine whether or not the frame is a wakeup frame. The MSB (thirty-first bit) must be zero. Bit j [30:0] is the Byte Mask. If bit j (byte number) of the Byte Mask is set, then Filter i Offset + j of the incoming frame is processed by the CRC block; otherwise Filter i Offset + j is ignored.
- **Filter i Command**  
 This 4-bit command controls the filter i operation. Bit 3 specifies the address type, defining the pattern's destination address type. When the bit is set, the pattern applies to only multicast frames. When the bit is reset, the pattern applies only to unicast frames. Bit 2 and bit 1 are reserved. Bit 0 is the enable bit for filter i; if bit 0 is not set, filter i is disabled.
- **Filter i Offset**  
 This register defines the offset (within the frame) from which the frames are examined by filter i. This 8-bit pattern offset is the offset for the filter i first byte to be examined. The minimum allowed is 12, which refers to the 13th byte of the frame (offset value 0 refers to the first byte of the frame).
- **Filter i CRC-16**  
 This register contains the CRC\_16 value calculated from the pattern, as well as the byte mask programmed to the wakeup filter register block.

**Remote wakeup frame detection**

When the MAC is in sleep mode and the remote wakeup bit is enabled in the ETH\_MACPMTCSR register, normal operation is resumed after receiving a remote wakeup frame. The application writes all eight wakeup filter registers, by performing a sequential write to the wakeup frame filter register address. The application enables remote wakeup by writing a 1 to bit 2 in the ETH\_MACPMTCSR register. PMT supports four programmable filters that provide different receive frame patterns. If the incoming frame passes the address filtering of Filter Command, and if Filter CRC-16 matches the incoming examined pattern, then the wakeup frame is received. Filter\_offset (minimum value 12, which refers to the 13th byte of the frame) determines the offset from which the frame is to be examined. Filter Byte

Mask determines which bytes of the frame must be examined. The thirty-first bit of Byte Mask must be set to zero. The wakeup frame is checked only for length error, FCS error, dribble bit error, MII error, collision, and to ensure that it is not a runt frame. Even if the wakeup frame is more than 512 bytes long, if the frame has a valid CRC value, it is considered valid. Wakeup frame detection is updated in the ETH\_MACPMTCSR register for every remote wakeup frame received. If enabled, a PMT interrupt is generated to indicate the reception of a remote wakeup frame.

**Magic packet detection**

The Magic Packet frame is based on a method that uses Advanced Micro Device’s Magic Packet technology to power up the sleeping device on the network. The MAC receives a specific packet of information, called a Magic Packet, addressed to the node on the network. Only Magic Packets that are addressed to the device or a broadcast address are checked to determine whether they meet the wakeup requirements. Magic Packets that pass address filtering (unicast or broadcast) are checked to determine whether they meet the remote Wake-on-LAN data format of 6 bytes of all ones followed by a MAC address appearing 16 times. The application enables Magic Packet wakeup by writing a 1 to bit 1 in the ETH\_MACPMTCSR register. The PMT block constantly monitors each frame addressed to the node for a specific Magic Packet pattern. Each received frame is checked for a 0xFFFF FFFF FFFF pattern following the destination and source address field. The PMT block then checks the frame for 16 repetitions of the MAC address without any breaks or interruptions. In case of a break in the 16 repetitions of the address, the 0xFFFF FFFF FFFF pattern is scanned for again in the incoming frame. The 16 repetitions can be anywhere in the frame, but must be preceded by the synchronization stream (0xFFFF FFFF FFFF). The device also accepts a multicast frame, as long as the 16 duplications of the MAC address are detected. If the MAC address of a node is 0x0011 2233 4455, then the MAC scans for the data sequence:

```

Destination address source address ..... FFFF FFFF FFFF
0011 2233 4455 0011 2233 4455 0011 2233 4455 0011 2233 4455
0011 2233 4455 0011 2233 4455 0011 2233 4455 0011 2233 4455
0011 2233 4455 0011 2233 4455 0011 2233 4455 0011 2233 4455
0011 2233 4455 0011 2233 4455 0011 2233 4455 0011 2233 4455
...CRC
    
```

Magic Packet detection is updated in the ETH\_MACPMTCSR register for received Magic Packet. If enabled, a PMT interrupt is generated to indicate the reception of a Magic Packet.

**System consideration during power-down**

The Ethernet PMT block is able to detect frames while the system is in the Stop mode, provided that the EXTI line 19 is enabled.

The MAC receiver state machine should remain enabled during the power-down mode. This means that the RE bit has to remain set in the ETH\_MACCCR register because it is involved in magic packet/ wake-on-LAN frame detection. The transmit state machine should however be turned off during the power-down mode by clearing the TE bit in the ETH\_MACCCR register. Moreover, the Ethernet DMA should be disabled during the power-down mode, because it is not necessary to copy the magic packet/wake-on-LAN frame into the SRAM. To disable the Ethernet DMA, clear the ST bit and the SR bit (for the transmit DMA and the receive DMA, respectively) in the ETH\_DMAOMR register.

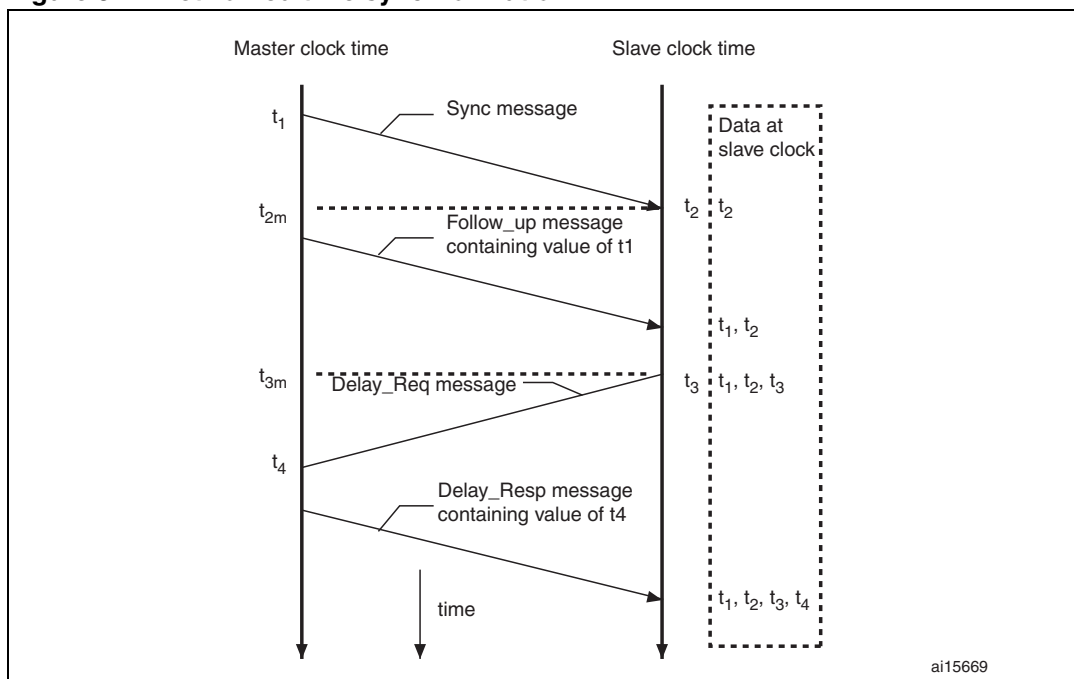
The recommended power-down and wakeup sequences are as follows:

1. Disable the transmit DMA and wait for any previous frame transmissions to complete. These transmissions can be detected when the transmit interrupt ETH\_DMASR register[0] is received.
2. Disable the MAC transmitter and MAC receiver by clearing the RE and TE bits in the ETH\_MACCR configuration register.
3. Wait for the receive DMA to have emptied all the frames in the Rx FIFO.
4. Disable the receive DMA.
5. Configure and enable the EXTI line 19 to generate either an event or an interrupt.
6. If you configure the EXTI line 19 to generate an interrupt, you also have to correctly configure the ETH\_WKUP\_IRQ Handler function, which should clear the pending bit of the EXTI line 19.
7. Enable Magic packet/Wake-on-LAN frame detection by setting the MFE/ WFE bit in the ETH\_MACPMTCSR register.
8. Enable the MAC power-down mode, by setting the PD bit in the ETH\_MACPMTCSR register.
9. Enable the MAC Receiver by setting the RE bit in the ETH\_MACCR register.
10. Enter the system's Stop mode (for more details refer to [Section 4.3.4: Stop mode](#)):
11. On receiving a valid wakeup frame, the Ethernet peripheral exits the power-down mode.
12. Read the ETH\_MACPMTCSR to clear the power management event flag, enable the MAC transmitter state machine, and the receive and transmit DMA.
13. Configure the system clock: enable the HSE and set the clocks.

### 28.5.9 Precision time protocol (IEEE1588 PTP)

The IEEE 1588 standard defines a protocol that allows precise clock synchronization in measurement and control systems implemented with technologies such as network communication, local computing and distributed objects. The protocol applies to systems that communicate by local area networks supporting multicast messaging, including (but not limited to) Ethernet. This protocol is used to synchronize heterogeneous systems that include clocks of varying inherent precision, resolution and stability. The protocol supports system-wide synchronization accuracy in the submicrosecond range with minimum network and local clock computing resources. The message-based protocol, known as the precision time protocol (PTP), is transported over UDP/IP. The system or network is classified into Master and Slave nodes for distributing the timing/clock information. The protocol's technique for synchronizing a slave node to a master node by exchanging PTP messages is described in [Figure 347](#).

Figure 347. Networked time synchronization



1. The master broadcasts PTP Sync messages to all its nodes. The Sync message contains the master's reference time information. The time at which this message leaves the master's system is  $t_1$ . For Ethernet ports, this time has to be captured at the MII.
2. A slave receives the Sync message and also captures the exact time,  $t_2$ , using its timing reference.
3. The master then sends the slave a Follow\_up message, which contains the  $t_1$  information for later use.
4. The slave sends the master a Delay\_Req message, noting the exact time,  $t_3$ , at which this frame leaves the MII.
5. The master receives this message and captures the exact time,  $t_4$ , at which it enters its system.
6. The master sends the  $t_4$  information to the slave in the Delay\_Resp message.
7. The slave uses the four values of  $t_1$ ,  $t_2$ ,  $t_3$ , and  $t_4$  to synchronize its local timing reference to the master's timing reference.

Most of the protocol implementation occurs in the software, above the UDP layer. As described above, however, hardware support is required to capture the exact time when specific PTP packets enter or leave the Ethernet port at the MII. This timing information has to be captured and returned to the software for a proper, high-accuracy implementation of PTP.

### Reference timing source

To get a snapshot of the time, the core requires a reference time in 64-bit format (split into two 32-bit channels, with the upper 32 bits providing time in seconds, and the lower 32 bits indicating time in nanoseconds) as defined in the IEEE 1588 specification.

The PTP reference clock input is used to internally generate the reference time (also called the System Time) and to capture time stamps. The frequency of this reference clock must

be greater than or equal to the resolution of time stamp counter. The synchronization accuracy target between the master node and the slaves is around 100 ns.

The generation, update and modification of the System Time are described in the [Section : System Time correction methods](#).

The accuracy depends on the PTP reference clock input period, the characteristics of the oscillator (drift) and the frequency of the synchronization procedure.

Due to the synchronization from the Tx and Rx clock input domain to the PTP reference clock domain, the uncertainty on the time stamp latched value is 1 reference clock period. If we add the uncertainty due to resolution, we will add half the period for time stamping.

### Transmission of frames with the PTP feature

When a frame's SFD is output on the MII, a time stamp is captured. Frames for which time stamp capture is required are controllable on a per-frame basis. In other words, each transmitted frame can be marked to indicate whether a time stamp must be captured or not for that frame. The transmitted frames are not processed to identify PTP frames. Frame control is exercised through the control bits in the transmit descriptor (as described in [Figure 355: Transmit descriptor field format with IEEE1588 time stamp enabled on page 966](#)). Captured time stamps are returned to the application in the same way as the status is provided for frames. The time stamp is sent back along with the Transmit status of the frame, inside the corresponding transmit descriptor, thus connecting the time stamp automatically to the specific PTP frame. The 64-bit time stamp information is written back to the TDES2 and TDES3 fields, with TDES2 holding the time stamp's 32 least significant bits as described in [Tx DMA descriptor format with IEEE1588 time stamp on page 965](#).

### Reception of frames with the PTP feature

When the IEEE 1588 time stamping feature is enabled, the Ethernet MAC captures the time stamp of all frames received on the MII. The received frames are not processed to identify PTP frames. The MAC provides the time stamp as soon as the frame reception is complete. Captured time stamps are returned to the application in the same way as the frame status is provided. The time stamp is sent back along with the Receive status of the frame, inside the corresponding receive descriptor. The 64-bit time stamp information is written back to the RDES2 and RDES3 fields, with RDES2 holding the time stamp's 32 least significant bits as described in [Rx DMA descriptor format with IEEE1588 time stamp on page 978](#).

### System Time correction methods

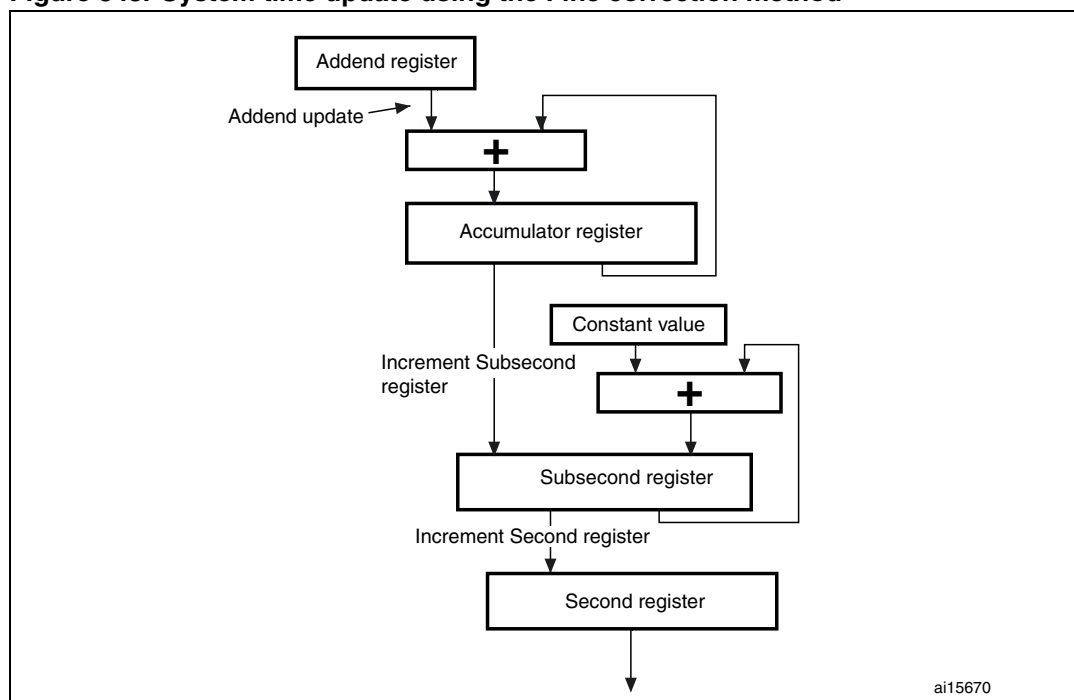
The 64-bit PTP time is updated using the PTP input reference clock, HCLK. This PTP time is used as a source to take snapshots (time stamps) of the Ethernet frames being transmitted or received at the MII. The System Time counter can be initialized or corrected using either the Coarse or the Fine correction method.

In the Coarse correction method, the initial value or the offset value is written to the Time stamp update register (refer to [Section 28.8.3: IEEE 1588 time stamp registers on page 1003](#)). For initialization, the System Time counter is written with the value in the Time stamp update registers, whereas for system time correction, the offset value (Time stamp update register) is added to or subtracted from the system time.

In the Fine correction method, the slave clock (reference clock) frequency drift with respect to the master clock (as defined in IEEE 1588) is corrected over a period of time, unlike in the Coarse correction method where it is corrected in a single clock cycle. The longer correction time helps maintain linear time and does not introduce drastic changes (or a large jitter) in

the reference time between PTP Sync message intervals. In this method, an accumulator sums up the contents of the Addend register as shown in [Figure 348](#). The arithmetic carry that the accumulator generates is used as a pulse to increment the system time counter. The accumulator and the addend are 32-bit registers. Here, the accumulator acts as a high-precision frequency multiplier or divider. [Figure 348](#) shows this algorithm.

**Figure 348. System time update using the Fine correction method**



The system time update logic requires a 50 MHz clock frequency to achieve 20 ns accuracy. The frequency division is the ratio of the reference clock frequency to the required clock frequency. Hence, if the reference clock (HCLK) is, let us say, 66 MHz, the ratio is calculated as  $66 \text{ MHz}/50 \text{ MHz} = 1.32$ . Hence, the default addend value to be set in the register is  $2^{32}/1.32$ , which is equal to `0xC1F0 7C1F`.

If the reference clock drifts lower, to 65 MHz for example, the ratio is  $65/50$  or  $1.3$  and the value to set in the addend register is  $2^{32}/1.30$  equal to `0xC4EC 4EC4`. If the clock drifts higher, to 67 MHz for example, the addend register must be set to `0xBF0 B7672`. When the clock drift is zero, the default addend value of `0xC1F0 7C1F` ( $2^{32}/1.32$ ) should be programmed.

In [Figure 348](#), the constant value used to increment the subsecond register is `0d43`. This makes an accuracy of 20 ns in the system time (in other words, it is incremented by 20 ns steps).

The software has to calculate the drift in frequency based on the Sync messages, and to update the Addend register accordingly. Initially, the slave clock is set with `FreqCompensationValue0` in the Addend register. This value is as follows:

$$\text{FreqCompensationValue0} = 2^{32} / \text{FreqDivisionRatio}$$

If `MasterToSlaveDelay` is initially assumed to be the same for consecutive Sync messages, the algorithm described below must be applied. After a few Sync cycles, frequency lock occurs. The slave clock can then determine a precise `MasterToSlaveDelay` value and re-synchronize with the master using the new value.

The algorithm is as follows:

- At time MasterSyncTime (n) the master sends the slave clock a Sync message. The slave receives this message when its local clock is SlaveClockTime (n) and computes MasterClockTime (n) as:  

$$\text{MasterClockTime (n)} = \text{MasterSyncTime (n)} + \text{MasterToSlaveDelay (n)}$$
- The master clock count for current Sync cycle, MasterClockCount (n) is given by:  

$$\text{MasterClockCount (n)} = \text{MasterClockTime (n)} - \text{MasterClockTime (n - 1)}$$
 (assuming that MasterToSlaveDelay is the same for Sync cycles n and n - 1)
- The slave clock count for current Sync cycle, SlaveClockCount (n) is given by:  

$$\text{SlaveClockCount (n)} = \text{SlaveClockTime (n)} - \text{SlaveClockTime (n - 1)}$$
- The difference between master and slave clock counts for current Sync cycle, ClockDiffCount (n) is given by:  

$$\text{ClockDiffCount (n)} = \text{MasterClockCount (n)} - \text{SlaveClockCount (n)}$$
- The frequency-scaling factor for slave clock, FreqScaleFactor (n) is given by:  

$$\text{FreqScaleFactor (n)} = (\text{MasterClockCount (n)} + \text{ClockDiffCount (n)}) / \text{SlaveClockCount (n)}$$
- The frequency compensation value for Addend register, FreqCompensationValue (n) is given by:  

$$\text{FreqCompensationValue (n)} = \text{FreqScaleFactor (n)} \times \text{FreqCompensationValue (n - 1)}$$

In theory, this algorithm achieves lock in one Sync cycle; however, it may take several cycles, due to changing network propagation delays and operating conditions.

This algorithm is self-correcting: if for any reason the slave clock is initially set to a value from the master that is incorrect, the algorithm corrects it at the cost of more Sync cycles.

### Programming steps for system time generation initialization

The time stamping feature can be enabled by setting bit 0 in the Time stamp control register (ETH\_PTPTSCR). However, it is essential to initialize the time stamp counter after this bit is set to start time stamp operation. The proper sequence is the following:

1. Mask the Time stamp trigger interrupt by setting bit 9 in the MACIMR register.
2. Program Time stamp register bit 0 to enable time stamping.
3. Program the Subsecond increment register based on the PTP clock frequency.
4. If you are using the Fine correction method, program the Time stamp addend register and set Time stamp control register bit 5 (addend register update).
5. Poll the Time stamp control register until bit 5 is cleared.
6. To select the Fine correction method (if required), program Time stamp control register bit 1.
7. Program the Time stamp high update and Time stamp low update registers with the appropriate time value.
8. Set Time stamp control register bit 2 (Time stamp init).
9. The Time stamp counter starts operation as soon as it is initialized with the value written in the Time stamp update register.
10. Enable the MAC receiver and transmitter for proper time stamping.

*Note: If time stamp operation is disabled by clearing bit 0 in the ETH\_PTPTSCR register, the above steps must be repeated to restart the time stamp operation.*

### Programming steps for system time update in the Coarse correction method

To synchronize or update the system time in one process (coarse correction method), perform the following steps:

1. Write the offset (positive or negative) in the Time stamp update high and low registers.
2. Set bit 3 (TSSTU) in the Time stamp control register.
3. The value in the Time stamp update registers is added to or subtracted from the system time when the TSSTU bit is cleared.

### Programming steps for system time update in the Fine correction method

To synchronize or update the system time to reduce system-time jitter (fine correction method), perform the following steps:

1. With the help of the algorithm explained in [Section : System Time correction methods](#), calculate the rate by which you want to speed up or slow down the system time increments.
2. Update the time stamp.
3. Wait the time you want the new value of the Addend register to be active. You can do this by activating the Time stamp trigger interrupt after the system time reaches the target value.
4. Program the required target time in the Target time high and low registers. Unmask the Time stamp interrupt by clearing bit 9 in the ETH\_MACIMR register.
5. Set Time stamp control register bit 4 (TSARU).
6. When this trigger causes an interrupt, read the ETH\_MACCSR register.
7. Reprogram the Time stamp addend register with the old value and set ETH\_TPTSCR bit 5 again.

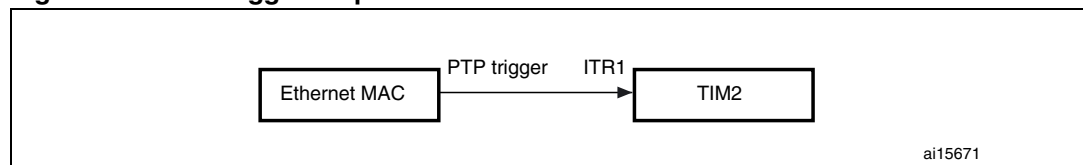
### PTP trigger internal connection with TIM2

The MAC provides a trigger interrupt when the system time becomes greater than the target time. Using an interrupt introduces a known latency plus an uncertainty in the command execution time.

In order to avoid this uncertainty, a PTP trigger output signal is set high when the system time is greater than the target time. It is internally connected to the TIM2 input trigger. With this signal, the input capture feature, the output compare feature and the waveforms of the timer can be used, triggered by the synchronized PTP system time. No uncertainty is introduced since the clock of the timer (PCLK1: TIM2 APB1 clock) and PTP reference clock (HCLK) are synchronous.

This PTP trigger signal is connected to the TIM2 ITR1 input selectable by software. The connection is enabled through bit 29 in the AFIO\_MAPR register. [Figure 349](#) shows the connection.

**Figure 349. PTP trigger output to TIM2 ITR1 connection**



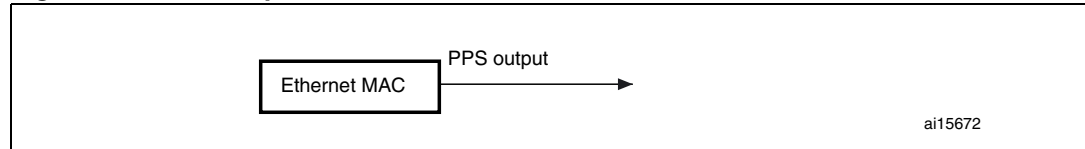


### PTP pulse-per-second output signal

This PTP pulse output is used to check the synchronization between all nodes in the network. To be able to test the difference between the local slave clock and the master reference clock, both clocks were given a pulse-per-second (PPS) output signal that may be connected to an oscilloscope if necessary. The deviation between the two signals can therefore be measured. The pulse width of the PPS output is 125 ms.

The PPS output is enabled through bit 30 in the AFIO\_MAPR register.

**Figure 350. PPS output**



## 28.6 Ethernet functional description: DMA controller operation

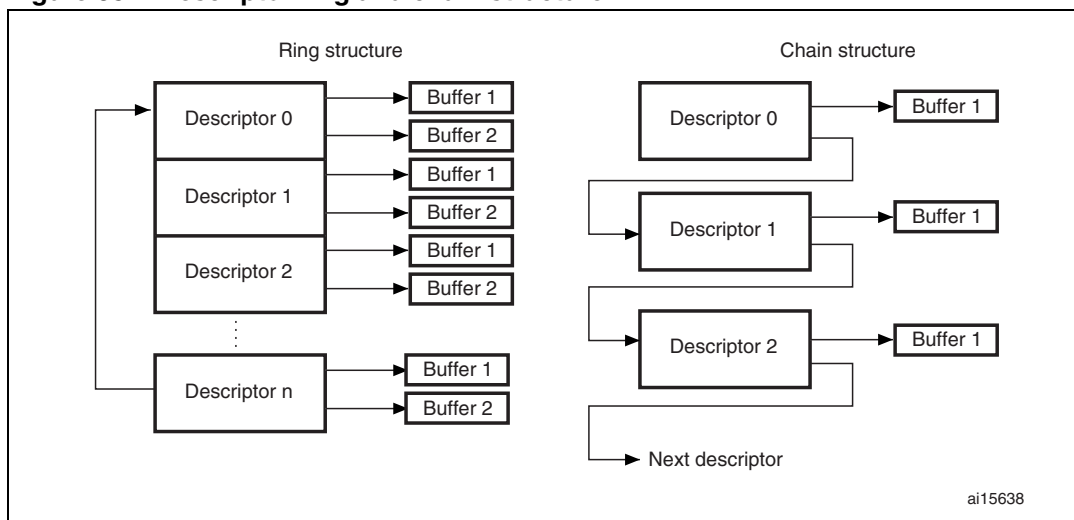
The DMA has independent transmit and receive engines, and a CSR space. The transmit engine transfers data from system memory into the Tx FIFO while the receive engine transfers data from the Rx FIFO into system memory. The controller utilizes descriptors to efficiently move data from source to destination with minimum CPU intervention. The DMA is designed for packet-oriented data transfers such as frames in Ethernet. The controller can be programmed to interrupt the CPU in cases such as frame transmit and receive transfer completion, and other normal/error conditions. The DMA and the STM32F107xx communicate through two data structures:

- Control and status registers (CSR)
- Descriptor lists and data buffers.

Control and status registers are described in detail in [Section 28.8 on page 981](#). Descriptors are described in detail in [Section on page 961](#).

The DMA transfers the received data frames to the receive buffer in the STM32F107xx memory, and transmits data frames from the transmit buffer in the STM32F107xx memory. Descriptors that reside in the STM32F107xx memory act as pointers to these buffers. There are two descriptor lists: one for reception, and one for transmission. The base address of each list is written into DMA Registers 3 and 4, respectively. A descriptor list is forward-linked (either implicitly or explicitly). The last descriptor may point back to the first entry to create a ring structure. Explicit chaining of descriptors is accomplished by configuring the second address chained in both the receive and transmit descriptors (RDES1[14] and TDES0[20]). The descriptor lists reside in the Host's physical memory space. Each descriptor can point to a maximum of two buffers. This enables the use of two physically addressed buffers, instead of two contiguous buffers in memory. A data buffer resides in the Host's physical memory space, and consists of an entire frame or part of a frame, but cannot exceed a single frame. Buffers contain only data. The buffer status is maintained in the descriptor. Data chaining refers to frames that span multiple data buffers. However, a single descriptor cannot span multiple frames. The DMA skips to the next frame buffer when the end of frame is detected. Data chaining can be enabled or disabled. The descriptor ring and chain structure is shown in [Figure 351](#).

Figure 351. Descriptor ring and chain structure



### 28.6.1 Initialization of a transfer using DMA

Initialization for the MAC is as follows:

1. Write to ETH\_DMABMR to set STM32F107xx bus access parameters.
2. Write to the ETH\_DMAIER register to mask unnecessary interrupt causes.
3. The software driver creates the transmit and receive descriptor lists. Then it writes to both the ETH\_DMARDLAR and ETH\_DMATDLAR registers, providing the DMA with the start address of each list.
4. Write to MAC Registers 1, 2, and 3 to choose the desired filtering options.
5. Write to the MAC ETH\_MACCCR register to configure and enable the transmit and receive operating modes. The PS and DM bits are set based on the auto-negotiation result (read from the PHY).
6. Write to the ETH\_DMAOMR register to set bits 13 and 1 and start transmission and reception.
7. The transmit and receive engines enter the running state and attempt to acquire descriptors from the respective descriptor lists. The receive and transmit engines then begin processing receive and transmit operations. The transmit and receive processes are independent of each other and can be started or stopped separately.

### 28.6.2 Host bus burst access

The DMA attempts to execute fixed-length burst transfers on the AHB master interface if configured to do so (FB bit in ETH\_DMABMR). The maximum burst length is indicated and limited by the PBL field (ETH\_DMABMR [13:8]). The receive and transmit descriptors are always accessed in the maximum possible burst size (limited by PBL) for the 16 bytes to be read.

The Transmit DMA initiates a data transfer only when there is sufficient space in the Transmit FIFO to accommodate the configured burst or the number of bytes until the end of frame (when it is less than the configured burst length). The DMA indicates the start address and the number of transfers required to the AHB Master Interface. When the AHB Interface is configured for fixed-length burst, then it transfers data using the best combination of

INCR4, INCR8, INCR16 and SINGLE transactions. Otherwise (no fixed-length burst), it transfers data using INCR (undefined length) and SINGLE transactions.

The Receive DMA initiates a data transfer only when sufficient data for the configured burst is available in Receive FIFO or when the end of frame (when it is less than the configured burst length) is detected in the Receive FIFO. The DMA indicates the start address and the number of transfers required to the AHB master interface. When the AHB interface is configured for fixed-length burst, then it transfers data using the best combination of INCR4, INCR8, INCR16 and SINGLE transactions. If the end of frame is reached before the fixed-burst ends on the AHB interface, then dummy transfers are performed in order to complete the fixed-length burst. Otherwise (FB bit in ETH\_DMABMR is reset), it transfers data using INCR (undefined length) and SINGLE transactions.

When the AHB interface is configured for address-aligned beats, both DMA engines ensure that the first burst transfer the AHB initiates is less than or equal to the size of the configured PBL. Thus, all subsequent beats start at an address that is aligned to the configured PBL. The DMA can only align the address for beats up to size 16 (for PBL > 16), because the AHB interface does not support more than INCR16.

### 28.6.3 Host data buffer alignment

The transmit and receive data buffers do not have any restrictions on start address alignment. In our system with 32-bit memory, the start address for the buffers can be aligned to any of the four bytes. However, the DMA always initiates transfers with address aligned to the bus width with dummy data for the byte lanes not required. This typically happens during the transfer of the beginning or end of an Ethernet frame.

- Example of buffer read:

If the Transmit buffer address is 0x0000 0FF2, and 15 bytes need to be transferred, then the DMA will read five full words from address 0x0000 0FF0, but when transferring data to the Transmit FIFO, the extra bytes (the first two bytes) will be dropped or ignored. Similarly, the last 3 bytes of the last transfer will also be ignored. The DMA always ensures it transfers a full 32-bit data items to the Transmit FIFO, unless it is the end of frame.

- Example of buffer write:

If the Receive buffer address is 0x0000 0FF2, and 16 bytes of a received frame need to be transferred, then the DMA will write five full 32-bit data items from address 0x0000 0FF0. But the first 2 bytes of the first transfer and the last 2 bytes of the third transfer will have dummy data.

### 28.6.4 Buffer size calculations

The DMA does not update the size fields in the transmit and receive descriptors. The DMA updates only the status fields (xDES0) of the descriptors. The driver has to calculate the sizes. The transmit DMA transfers the exact number of bytes (indicated by buffer size field in TDES1) towards the MAC core. If a descriptor is marked as first (FS bit in TDES0 is set), then the DMA marks the first transfer from the buffer as the start of frame. If a descriptor is marked as last (LS bit in TDES0), then the DMA marks the last transfer from that data buffer as the end of frame. The receive DMA transfers data to a buffer until the buffer is full or the end of frame is received. If a descriptor is not marked as last (LS bit in RDES0), then the buffer(s) that correspond to the descriptor are full and the amount of valid data in a buffer is accurately indicated by the buffer size field minus the data buffer pointer offset when the descriptor's FS bit is set. The offset is zero when the data buffer pointer is aligned to the

databus width. If a descriptor is marked as last, then the buffer may not be full (as indicated by the buffer size in RDES1). To compute the amount of valid data in this final buffer, the driver must read the frame length (FL bits in RDES0[29:16]) and subtract the sum of the buffer sizes of the preceding buffers in this frame. The receive DMA always transfers the start of next frame with a new descriptor.

*Note:* Even when the start address of a receive buffer is not aligned to the system databus width the system should allocate a receive buffer of a size aligned to the system bus width. For example, if the system allocates a 1024 byte (1 KB) receive buffer starting from address 0x1000, the software can program the buffer start address in the receive descriptor to have a 0x1002 offset. The receive DMA writes the frame to this buffer with dummy data in the first two locations (0x1000 and 0x1001). The actual frame is written from location 0x1002. Thus, the actual useful space in this buffer is 1022 bytes, even though the buffer size is programmed as 1024 bytes, due to the start address offset.

### 28.6.5 DMA arbiter

The arbiter inside the DMA takes care of the arbitration between transmit and receive channel accesses to the AHB master interface. Two types of arbitrations are possible: round-robin, and fixed-priority. When round-robin arbitration is selected (DA bit in ETH\_DMABMR is reset), the arbiter allocates the databus in the ratio set by the RTPR bits in ETH\_DMABMR, when both transmit and receive DMAs request access simultaneously. When the DA bit is set, the receive DMA always gets priority over the transmit DMA for data access.

### 28.6.6 Error response to DMA

For any data transfer initiated by a DMA channel, if the slave replies with an error response, that DMA stops all operations and updates the error bits and the fatal bus error bit in the Status register (ETH\_DMASR register). That DMA controller can resume operation only after soft- or hard-resetting the peripheral and re-initializing the DMA.

### 28.6.7 Tx DMA configuration

#### TxDMA operation: default (non-OSF) mode

The transmit DMA engine in default mode proceeds as follows:

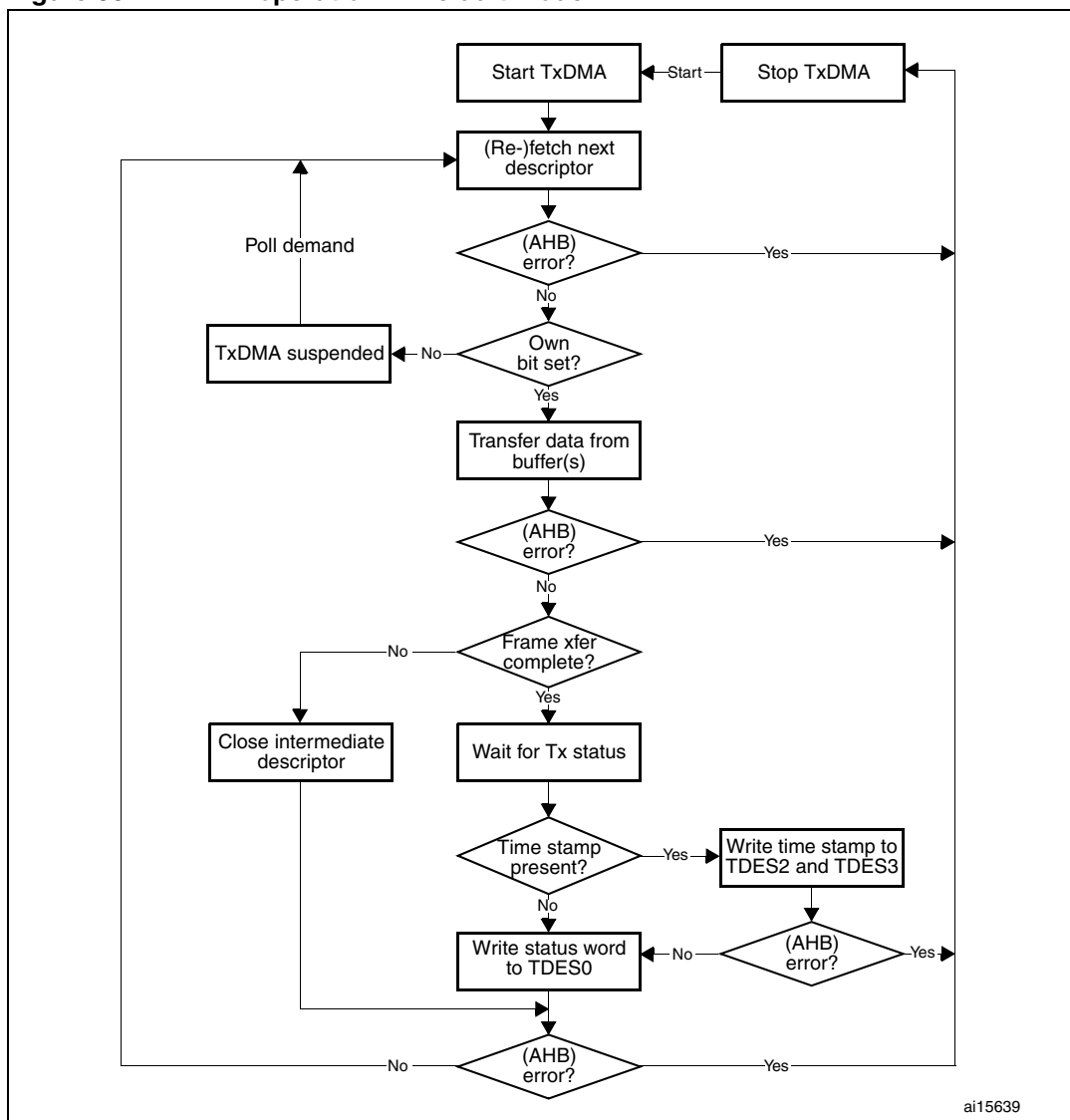
1. The user sets up the transmit descriptor (TDES0-TDES3) and sets the OWN bit (TDES0[31]) after setting up the corresponding data buffer(s) with Ethernet frame data.
2. Once the ST bit (ETH\_DMAOMR register[13]) is set, the DMA enters the Run state.
3. While in the Run state, the DMA polls the transmit descriptor list for frames requiring transmission. After polling starts, it continues in either sequential descriptor ring order or chained order. If the DMA detects a descriptor flagged as owned by the CPU, or if an error condition occurs, transmission is suspended and both the Transmit Buffer

Unavailable (ETH\_DMASR register[2]) and Normal Interrupt Summary (ETH\_DMASR register[16]) bits are set. The transmit engine proceeds to Step 9.

4. If the acquired descriptor is flagged as owned by DMA (TDES0[31] is set), the DMA decodes the transmit data buffer address from the acquired descriptor.
5. The DMA fetches the transmit data from the STM32F107xx memory and transfers the data.
6. If an Ethernet frame is stored over data buffers in multiple descriptors, the DMA closes the intermediate descriptor and fetches the next descriptor. Steps 3, 4, and 5 are repeated until the end of Ethernet frame data is transferred.
7. When frame transmission is complete, if IEEE 1588 time stamping was enabled for the frame (as indicated in the transmit status) the time stamp value is written to the transmit descriptor (TDES2 and TDES3) that contains the end-of-frame buffer. The status information is then written to this transmit descriptor (TDES0). Because the OWN bit is cleared during this step, the CPU now owns this descriptor. If time stamping was not enabled for this frame, the DMA does not alter the contents of TDES2 and TDES3.
8. Transmit Interrupt (ETH\_DMASR register [0]) is set after completing the transmission of a frame that has Interrupt on Completion (TDES1[31]) set in its last descriptor. The DMA engine then returns to Step 3.
9. In the Suspend state, the DMA tries to re-acquire the descriptor (and thereby returns to Step 3) when it receives a transmit poll demand, and the Underflow Interrupt Status bit is cleared.

*Figure 352* shows the TxDMA transmission flow in default mode.

Figure 352. TxDMA operation in Default mode



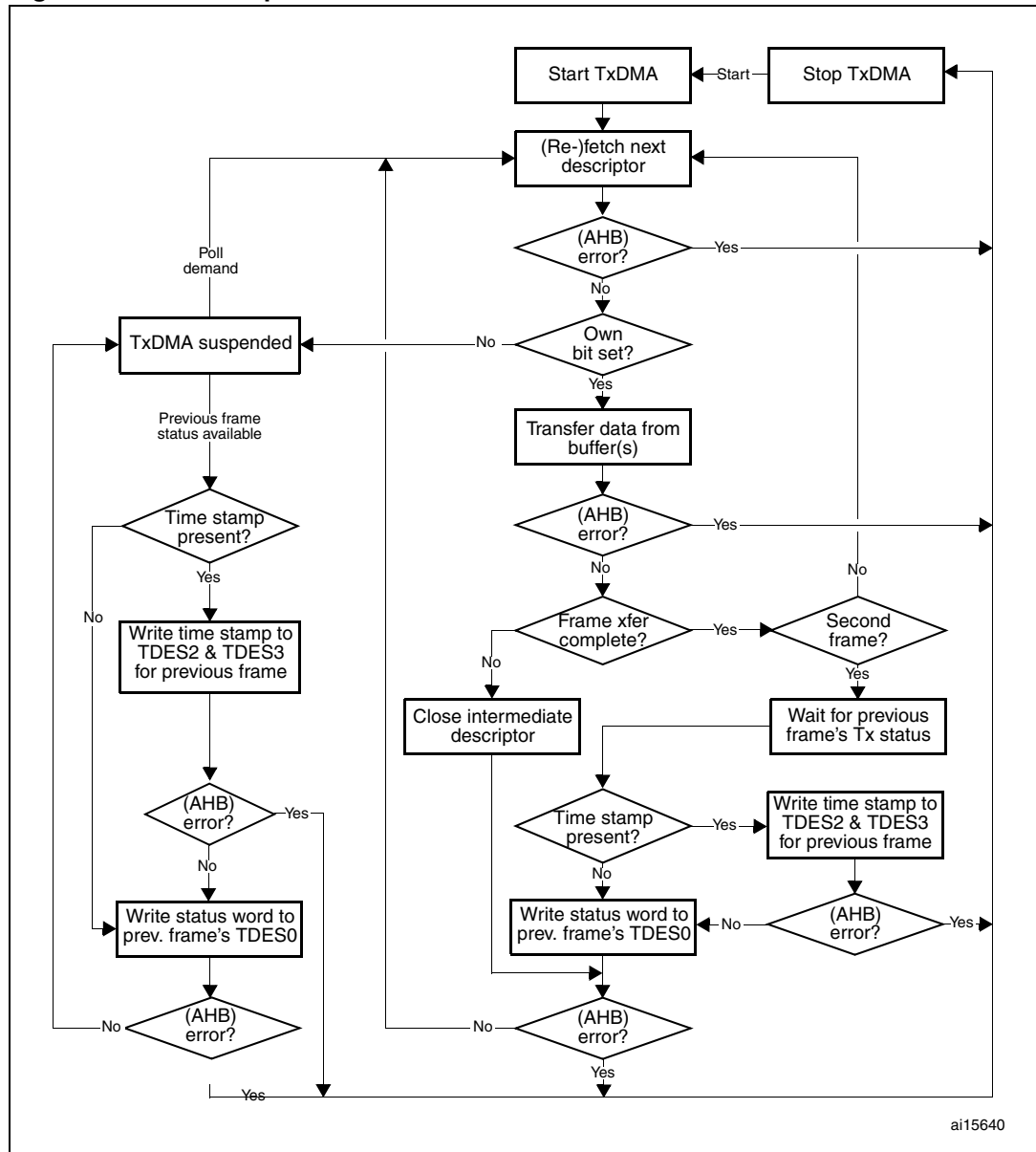
**TxDMA operation: OSF mode**

While in the Run state, the transmit process can simultaneously acquire two frames without closing the Status descriptor of the first (if the OSF bit is set in ETH\_DMAOMR register[2]). As the transmit process finishes transferring the first frame, it immediately polls the transmit descriptor list for the second frame. If the second frame is valid, the transmit process transfers this frame before writing the first frame’s status information. In OSF mode, the Run-state transmit DMA operates according to the following sequence:

1. The DMA operates as described in steps 1–6 of the TxDMA (default mode).
2. Without closing the previous frame's last descriptor, the DMA fetches the next descriptor.
3. If the DMA owns the acquired descriptor, the DMA decodes the transmit buffer address in this descriptor. If the DMA does not own the descriptor, the DMA goes into Suspend mode and skips to Step 7.
4. The DMA fetches the Transmit frame from the STM32F107xx memory and transfers the frame until the end of frame data are transferred, closing the intermediate descriptors if this frame is split across multiple descriptors.
5. The DMA waits for the transmission status and time stamp of the previous frame. When the status is available, the DMA writes the time stamp to TDES2 and TDES3, if such time stamp was captured (as indicated by a status bit). The DMA then writes the status, with a cleared OWN bit, to the corresponding TDES0, thus closing the descriptor. If time stamping was not enabled for the previous frame, the DMA does not alter the contents of TDES2 and TDES3.
6. If enabled, the Transmit interrupt is set, the DMA fetches the next descriptor, then proceeds to Step 3 (when Status is normal). If the previous transmission status shows an underflow error, the DMA goes into Suspend mode (Step 7).
7. In Suspend mode, if a pending status and time stamp are received by the DMA, it writes the time stamp (if enabled for the current frame) to TDES2 and TDES3, then writes the status to the corresponding TDES0. It then sets relevant interrupts and returns to Suspend mode.
8. The DMA can exit Suspend mode and enter the Run state (go to Step 1 or Step 2 depending on pending status) only after receiving a Transmit Poll demand (ETH\_DMATPDR register).

*Figure 353* shows the basic flowchart in OSF mode.

Figure 353. TxDMA operation in OSF mode



### Transmit frame processing

The transmit DMA expects that the data buffers contain complete Ethernet frames, excluding preamble, pad bytes, and FCS fields. The DA, SA, and Type/Len fields contain valid data. If the transmit descriptor indicates that the MAC core must disable CRC or pad insertion, the buffer must have complete Ethernet frames (excluding preamble), including the CRC bytes. Frames can be data-chained and span over several buffers. Frames have to be delimited by the first descriptor (TDES0[28]) and the last descriptor (TDES0[29]). As the transmission starts, TDES0[28] has to be set in the first descriptor. When this occurs, the frame data are transferred from the memory buffer to the Transmit FIFO. Concurrently, if the last descriptor (TDES0[29]) of the current frame is cleared, the transmit process attempts to acquire the next descriptor. The transmit process expects TDES0[28] to be cleared in this descriptor. If TDES0[29] is cleared, it indicates an intermediary buffer. If TDES0[29] is set, it



indicates the last buffer of the frame. After the last buffer of the frame has been transmitted, the DMA writes back the final status information to the transmit descriptor 0 (TDES0) word of the descriptor that has the last segment set in transmit descriptor 0 (TDES0[29]). At this time, if Interrupt on Completion (TDES0[30]) is set, Transmit Interrupt (in ETH\_DMASR register [0]) is set, the next descriptor is fetched, and the process repeats. Actual frame transmission begins after the Transmit FIFO has reached either a programmable transmit threshold (ETH\_DMAOMR register[16:14]), or a full frame is contained in the FIFO. There is also an option for the Store and forward mode (ETH\_DMAOMR register[21]). Descriptors are released (OWN bit TDES0[31] is cleared) when the DMA finishes transferring the frame.

**Transmit polling suspended**

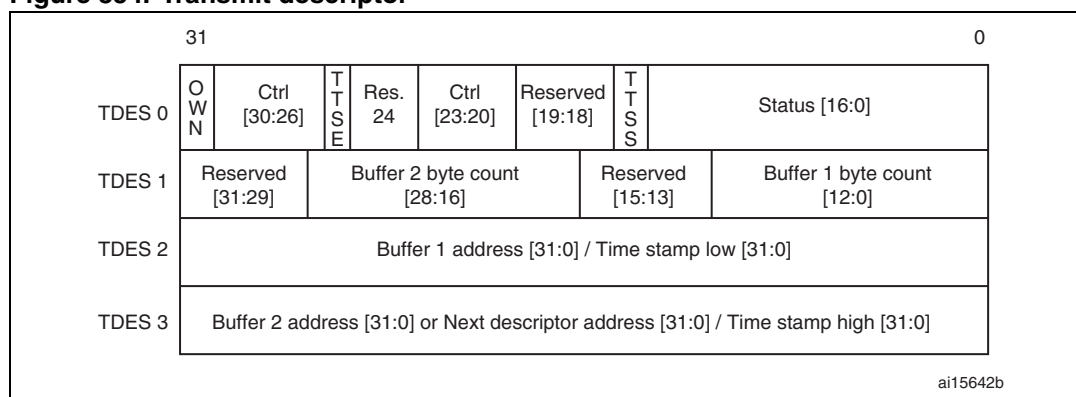
Transmit polling can be suspended by either of the following conditions:

- The DMA detects a descriptor owned by the CPU (TDES0[31]=0) and the Transmit buffer unavailable flag is set (ETH\_DMASR register[2]). To resume, the driver must give descriptor ownership to the DMA and then issue a Poll Demand command.
- A frame transmission is aborted when a transmit error due to underflow is detected. The appropriate Transmit Descriptor 0 (TDES0) bit is set. If the second condition occurs, both the Abnormal Interrupt Summary (in ETH\_DMASR register [15]) and Transmit Underflow bits (in ETH\_DMASR register[5]) are set, and the information is written to Transmit Descriptor 0, causing the suspension. If the DMA goes into Suspend state due to the first condition, then both the Normal Interrupt Summary (ETH\_DMASR register [16]) and Transmit Buffer Unavailable (ETH\_DMASR register[2]) bits are set. In both cases, the position in the transmit list is retained. The retained position is that of the descriptor following the last descriptor closed by the DMA. The driver must explicitly issue a Transmit Poll Demand command after rectifying the suspension cause.

**Tx DMA descriptors**

The descriptor structure consists of four 32-bit words as shown in [Figure 354](#). The bit descriptions of TDES0, TDES1, TDES2 and TDES3 are given below.

**Figure 354. Transmit descriptor**



● **TDES0: Transmit descriptor Word0**

The application software has to program the control bits [30:26]+[23:20] plus the OWN bit [31] during descriptor initialization. When the DMA updates the descriptor (or writes it back), it resets all the control bits plus the OWN bit, and reports only the status bits.

31	30	29	28	27	26	25	24	23	22	21	20	19	18	17	16	15	14	13	12	11	10	9	8	7	6	5	4	3	2	1	0	
OWN	IC	LS	FS	DC	DP	TTSE	Res.	CIC		TER	TC	Res.		TTSS	IHE	ES	JT	FF	IP	LC	NC	LC	EC	VF	CC				ED	UF	DB	
rw	rw	rw	rw	rw	rw	rw		rw	rw	rw	rw			rw	rw	rw	rw	rw	rw	rw	rw	rw	rw	rw	rw	rw	rw	rw	rw	rw	rw	rw

**Bit 31 OWN:** Own bit

When set, this bit indicates that the descriptor is owned by the DMA. When this bit is reset, it indicates that the descriptor is owned by the CPU. The DMA clears this bit either when it completes the frame transmission or when the buffers allocated in the descriptor are read completely. The ownership bit of the frame's first descriptor must be set after all subsequent descriptors belonging to the same frame have been set.

**Bit 30 IC:** Interrupt on completion

When set, this bit sets the Transmit Interrupt (Register 5[0]) after the present frame has been transmitted.

**Bit 29 LS:** Last segment

When set, this bit indicates that the buffer contains the last segment of the frame.

**Bit 28 FS:** First segment

When set, this bit indicates that the buffer contains the first segment of a frame.

**Bit 27 DC:** Disable CRC

When this bit is set, the MAC does not append a cyclic redundancy check (CRC) to the end of the transmitted frame. This is valid only when the first segment (TDES0[28]) is set.

**Bit 26 DP:** Disable pad

When set, the MAC does not automatically add padding to a frame shorter than 64 bytes. When this bit is reset, the DMA automatically adds padding and CRC to a frame shorter than 64 bytes, and the CRC field is added despite the state of the DC (TDES0[27]) bit. This is valid only when the first segment (TDES0[28]) is set.

**Bit 25 TTSE:** Transmit time stamp enable

When TTSE is set and when TSE is set (ETH\_PTPTSCR bit 0), IEEE1588 hardware time stamping is activated for the transmit frame described by the descriptor. This field is only valid when the First segment control bit (TDES0[28]) is set.

**Bit 24** Reserved

**Bits 23:22 CIC:** Checksum insertion control

These bits control the checksum calculation and insertion. Bit encoding is as shown below:

00: Checksum Insertion disabled

01: Only IP header checksum calculation and insertion are enabled

10: IP header checksum and payload checksum calculation and insertion are enabled, but pseudo-header checksum is not calculated in hardware

11: IP Header checksum and payload checksum calculation and insertion are enabled, and pseudo-header checksum is calculated in hardware.

**Bit 21 TER:** Transmit end of ring

When set, this bit indicates that the descriptor list reached its final descriptor. The DMA returns to the base address of the list, creating a descriptor ring.

**Bit 20 TCH:** Second address chained

When set, this bit indicates that the second address in the descriptor is the next descriptor address rather than the second buffer address. When TDES0[20] is set, TBS2 (TDES1[28:16]) is a “don’t care” value. TDES0[21] takes precedence over TDES0[20].

## Bits 19:18 Reserved

**Bit 17 TTSS:** Transmit time stamp status

This field is used as a status bit to indicate that a time stamp was captured for the described transmit frame. When this bit is set, TDES2 and TDES3 have a time stamp value captured for the transmit frame. This field is only valid when the descriptor’s Last segment control bit (TDES0[29]) is set.

**Bit 16 IHE:** IP header error

When set, this bit indicates that the MAC transmitter detected an error in the IP datagram header. The transmitter checks the header length in the IPv4 packet against the number of header bytes received from the application and indicates an error status if there is a mismatch. For IPv6 frames, a header error is reported if the main header length is not 40 bytes. Furthermore, the Ethernet length/type field value for an IPv4 or IPv6 frame must match the IP header version received with the packet. For IPv4 frames, an error status is also indicated if the Header Length field has a value less than 0x5.

**Bit 15 ES:** Error summary

Indicates the logical OR of the following bits:

- TDES0[14]: Jabber timeout
- TDES0[13]: Frame flush
- TDES0[11]: Loss of carrier
- TDES0[10]: No carrier
- TDES0[9]: Late collision
- TDES0[8]: Excessive collision
- TDES0[2]: Excessive deferral
- TDES0[1]: Underflow error
- TDES0[16]: IP header error
- TDES0[12]: IP payload error

**Bit 14 JT:** Jabber timeout

When set, this bit indicates the MAC transmitter has experienced a jabber timeout. This bit is only set when the MAC configuration register’s JD bit is not set.

**Bit 13 FF:** Frame flushed

When set, this bit indicates that the DMA/MTL flushed the frame due to a software Flush command given by the CPU.

**Bit 12 IPE:** IP payload error

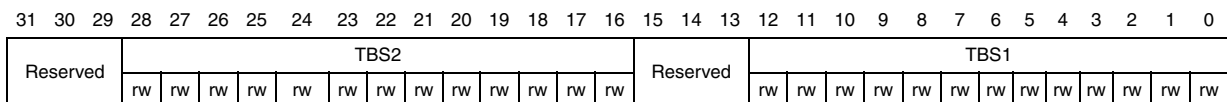
When set, this bit indicates that MAC transmitter detected an error in the TCP, UDP, or ICMP IP datagram payload. The transmitter checks the payload length received in the IPv4 or IPv6 header against the actual number of TCP, UDP or ICMP packet bytes received from the application and issues an error status in case of a mismatch.

**Bit 11 LCA:** Loss of carrier

When set, this bit indicates that a loss of carrier occurred during frame transmission (that is, the MII\_CRFS signal was inactive for one or more transmit clock periods during frame transmission). This is valid only for the frames transmitted without collision when the MAC operates in Half-duplex mode.

- Bit 10 **NC**: No carrier  
When set, this bit indicates that the Carrier Sense signal from the PHY was not asserted during transmission.
- Bit 9 **LCO**: Late collision  
When set, this bit indicates that frame transmission was aborted due to a collision occurring after the collision window (64 byte times, including preamble, in MII mode). This bit is not valid if the Underflow Error bit is set.
- Bit 8 **EC**: Excessive collision  
When set, this bit indicates that the transmission was aborted after 16 successive collisions while attempting to transmit the current frame. If the RD (Disable retry) bit in the MAC Configuration register is set, this bit is set after the first collision, and the transmission of the frame is aborted.
- Bit 7 **VF**: VLAN frame  
When set, this bit indicates that the transmitted frame was a VLAN-type frame.
- Bits 6:3 **CC**: Collision count  
This 4-bit counter value indicates the number of collisions occurring before the frame was transmitted. The count is not valid when the Excessive collisions bit (TDES0[8]) is set.
- Bit 2 **ED**: Excessive deferral  
When set, this bit indicates that the transmission has ended because of excessive deferral of over 24 288 bit times if the Deferral check (DC) bit in the MAC Control register is set high.
- Bit 1 **UF**: Underflow error  
When set, this bit indicates that the MAC aborted the frame because data arrived late from the RAM memory. Underflow error indicates that the DMA encountered an empty transmit buffer while transmitting the frame. The transmission process enters the Suspended state and sets both Transmit underflow (Register 5[5]) and Transmit interrupt (Register 5[0]).
- Bit 0 **DB**: Deferred bit  
When set, this bit indicates that the MAC defers before transmission because of the presence of the carrier. This bit is valid only in Half-duplex mode.

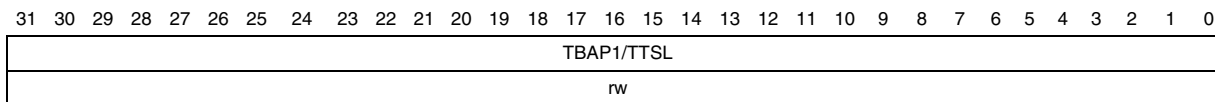
● **TDES1: Transmit descriptor Word1**



- 31:29 Reserved
- 28:16 **TBS2**: Transmit buffer 2 size  
These bits indicate the second data buffer size in bytes. This field is not valid if TDES0[20] is set.
- 15:13 Reserved
- 12:0 **TBS1**: Transmit buffer 1 size  
These bits indicate the first data buffer byte size, in bytes. If this field is 0, the DMA ignores this buffer and uses Buffer 2 or the next descriptor, depending on the value of TCH (TDES0[20]).

- **TDES2: Transmit descriptor Word2**

TDES2 contains the address pointer to the first buffer of the descriptor or it contains time stamp data.



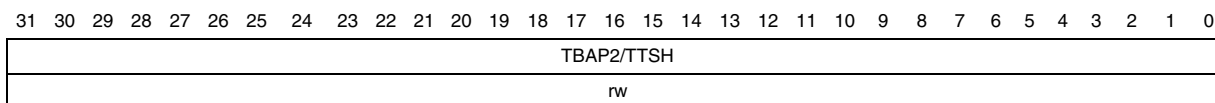
Bits 31:0 **TBAP1 / TTSL**: Transmit buffer 1 address pointer / Transmit frame time stamp low  
 These bits take on two different functions: the application uses them to indicate to the DMA the location of data in memory. And then after transferring all these data, the DMA may then use these bits to pass back time stamp data.

**TBAP**: When the software makes this descriptor available to the DMA (at the moment that the OWN bit is set to 1 in TDES0), these bits indicate the physical address of Buffer 1. There is no limitation on the buffer address alignment. See [Host data buffer alignment on page 955](#) for further details on buffer address alignment.

**TTSL**: Before it clears the OWN bit in TDES0, the DMA updates this field with the 32 least significant bits of the time stamp captured for the corresponding transmit frame (overwriting the value for TBAP1). This field has the time stamp only if time stamping is activated for this frame (see TTSE, TDES0 bit 25) and if the Last segment control bit (LS) in the descriptor is set.

- **TDES3: Transmit descriptor Word3**

TDES3 contains the address pointer either to the second buffer of the descriptor or the next descriptor, or it contains time stamp data.



Bits 31:0 **TBAP2 / TTSH**: Transmit buffer 2 address pointer (Next descriptor address) / Transmit frame time stamp high  
 These bits take on two different functions: the application uses them to indicate to the DMA the location of data in memory. And then after transferring all these data, the DMA may then use these bits to pass back time stamp data.

**TBAP2**: When the software makes this descriptor available to the DMA (at the moment when the OWN bit is set to 1 in TDES0), these bits indicate the physical address of Buffer 2 when a descriptor ring structure is used. If the Second address chained (TDES1 [24]) bit is set, this address contains the pointer to the physical memory where the next descriptor is present. The buffer address pointer must be aligned to the bus width only when TDES1 [24] is set. (LSBs are ignored internally.)

**TTSH**: Before it clears the OWN bit in TDES0, the DMA updates this field with the 32 most significant bits of the time stamp captured for the corresponding transmit frame (overwriting the value for TBAP2). This field has the time stamp only if time stamping is activated for this frame (see TDES0 bit 25, TTSE) and if the Last segment control bit (LS) in the descriptor is set.

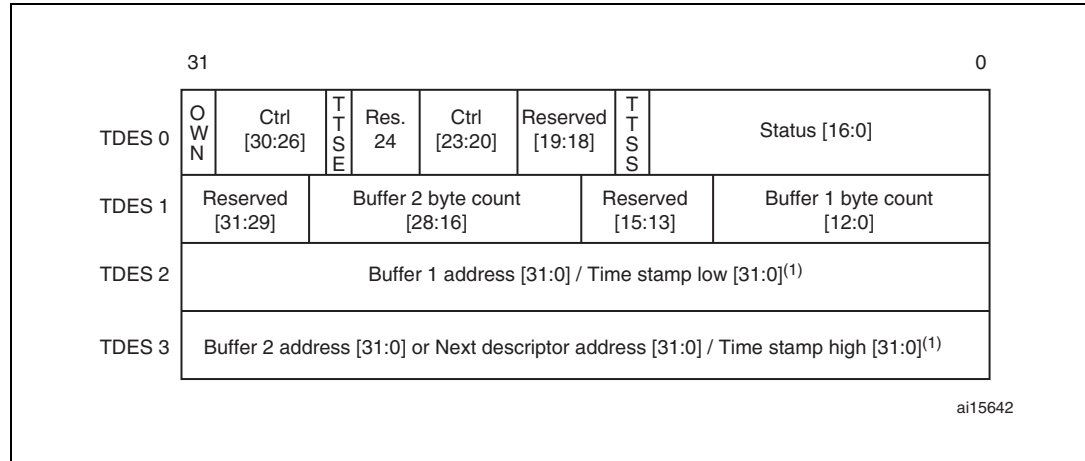
### Tx DMA descriptor format with IEEE1588 time stamp

The descriptor format (as described previously) and field descriptions remain unchanged when created by software (OWN bit is set in TDES0). However, if the software has enabled

the IEEE 1588 functionality, the TDES2 and TDES3 descriptor fields take on a different meaning when the DMA closes the descriptor (OWN bit in TDES0 is cleared).

The Transmit descriptor has additional control and status bits (TTSE and TTSS, respectively) for time stamping, as shown in [Figure 355](#). The software sets the TTSE bit (when the OWN bit is set), instructing the core to generate a time stamp for the corresponding Ethernet frame being transmitted. The DMA sets the TTSS bit if the time stamp has been updated in the TDES2 and TDES3 fields when the descriptor is closed (OWN bit is cleared).

**Figure 355. Transmit descriptor field format with IEEE1588 time stamp enabled**



1. The DMA updates TDES2 and TDES3 with the time stamp value before clearing the OWN bit in TDES0: TDES2 is updated with the lower 32 time stamp bits (the sub-second field, called TTSL in subsequent section [TDES2: Transmit descriptor Word2](#)) and TDES3 is updated with the upper 32 time stamp bits (the Seconds field, called TTSH in subsequent sections [TDES3: Transmit descriptor Word3](#))

● **TDES0: Transmit descriptor Word0: Transmit time stamp control and status**

The value of this field should be preserved by the DMA at the time of closing the descriptor.

31	30	29	28	27	26	25	24	23	22	21	20	19	18	17	16	15	14	13	12	11	10	9	8	7	6	5	4	3	2	1	0
OWN	IC	LS	FS	DC	DP	TTSE	Res.	CIC		TER	TOH	Res.	SS	HE	ES	JT	FF	IPE	LA	NC	LO	EC	VF	CC				ED	UF	DB	
rw	rw	rw	rw	rw	rw	rw		rw	rw	rw	rw		rw	rw	rw	rw	rw	rw	rw	rw	rw	rw	rw	rw	rw	rw	rw	rw	rw	rw	rw

Bit 31 **OWN**: Own bit

When set, this bit indicates that the descriptor is owned by the DMA. When this bit is reset, it indicates that the descriptor is owned by the CPU. The DMA clears this bit either when it completes the frame transmission or when the buffers allocated in the descriptor are read completely. The ownership bit of the frame's first descriptor must be set after all subsequent descriptors belonging to the same frame have been set.

Bit 30 **IC**: Interrupt on completion

When set, this bit sets the Transmit Interrupt (Register 5[0]) after the present frame has been transmitted.

Bit 29 **LS**: Last segment

When set, this bit indicates that the buffer contains the last segment of the frame.

Bit 28 **FS**: First segment

When set, this bit indicates that the buffer contains the first segment of a frame.

Bit 27 **DC**: Disable CRC

When this bit is set, the MAC does not append a cyclic redundancy check (CRC) to the end of the transmitted frame. This is valid only when the first segment (TDES0[28]) is set.

Bit 26 **DP**: Disable pad

When set, the MAC does not automatically add padding to a frame shorter than 64 bytes. When this bit is reset, the DMA automatically adds padding and CRC to a frame shorter than 64 bytes, and the CRC field is added despite the state of the DC (TDES0[27]) bit. This is valid only when the first segment (TDES0[28]) is set.

Bit 25 **TTSE**: Transmit time stamp enable

When set, this field enables IEEE1588 hardware time stamping for the transmit frame described by the descriptor. This field is only valid when the First segment control bit (TDES0[28]) is set.

Bit 24 Reserved

Bits 23:22 **CIC**: Checksum insertion control

These bits control the checksum calculation and insertion. Bit encoding is as shown below:

00: Checksum Insertion disabled

01: Only IP header checksum calculation and insertion are enabled

10: IP header checksum and payload checksum calculation and insertion are enabled, but pseudo-header checksum is not calculated in hardware

11: IP Header checksum and payload checksum calculation and insertion are enabled, and pseudo-header checksum is calculated in hardware.

Bit 21 **TER**: Transmit end of ring

When set, this bit indicates that the descriptor list reached its final descriptor. The DMA returns to the base address of the list, creating a descriptor ring.

**Bit 20 TCH:** Second address chained

When set, this bit indicates that the second address in the descriptor is the next descriptor address rather than the second buffer address. When TDES0[20] is set, TBS2 (TDES1[28:16]) is a “don’t care” value. TDES0[21] takes precedence over TDES0[20].

## Bits 19:18 Reserved

**Bits 17 TTSS:** Transmit time stamp status

This field is used as a status bit to indicate that a time stamp was captured for the described transmit frame. When this bit is set, TDES2 and TDES3 have a time stamp value captured for the transmit frame. This field is only valid when the descriptor’s Last segment control bit (TDES0[29]) is set.

**Bit 16 IHE:** IP header error

When set, this bit indicates that the MAC transmitter detected an error in the IP datagram header. The transmitter checks the header length in the IPv4 packet against the number of header bytes received from the application and indicates an error status if there is a mismatch. For IPv6 frames, a header error is reported if the main header length is not 40 bytes. Furthermore, the Ethernet length/type field value for an IPv4 or IPv6 frame must match the IP header version received with the packet. For IPv4 frames, an error status is also indicated if the Header Length field has a value less than 0x5.

**Bit 15 ES:** Error summary

Indicates the logical OR of the following bits:

- TDES0[14]: Jabber timeout
- TDES0[13]: Frame flush
- TDES0[11]: Loss of carrier
- TDES0[10]: No carrier
- TDES0[9]: Late collision
- TDES0[8]: Excessive collision
- TDES0[2]: Excessive deferral
- TDES0[1]: Underflow error
- TDES0[16]: IP header error
- TDES0[12]: IP payload error

**Bit 14 JT:** Jabber timeout

When set, this bit indicates the MAC transmitter has experienced a jabber timeout. This bit is only set when the MAC configuration register’s JD bit is not set.

**Bit 13 FF:** Frame flushed

When set, this bit indicates that the DMA/MTL flushed the frame due to a software Flush command given by the CPU.

**Bit 12 IPE:** IP payload error

When set, this bit indicates that MAC transmitter detected an error in the TCP, UDP, or ICMP IP datagram payload. The transmitter checks the payload length received in the IPv4 or IPv6 header against the actual number of TCP, UDP or ICMP packet bytes received from the application and issues an error status in case of a mismatch.

**Bit 11 LCA:** Loss of carrier

When set, this bit indicates that a loss of carrier occurred during frame transmission (that is, the MII\_CRS signal was inactive for one or more transmit clock periods during frame transmission). This is valid only for the frames transmitted without collision when the MAC operates in Half-duplex mode.

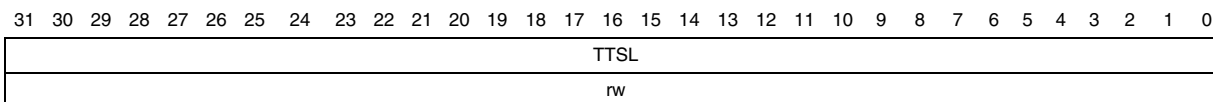


- Bit 10 **NC**: No carrier  
When set, this bit indicates that the Carrier Sense signal from the PHY was not asserted during transmission.
- Bit 9 **LCO**: Late collision  
When set, this bit indicates that frame transmission was aborted due to a collision occurring after the collision window (64 byte times, including preamble, in MII mode). This bit is not valid if the Underflow Error bit is set.
- Bit 8 **EC**: Excessive collision  
When set, this bit indicates that the transmission was aborted after 16 successive collisions while attempting to transmit the current frame. If the RD (Disable retry) bit in the MAC Configuration register is set, this bit is set after the first collision, and the transmission of the frame is aborted.
- Bit 7 **VF**: VLAN frame  
When set, this bit indicates that the transmitted frame was a VLAN-type frame.
- Bits 6:3 **CC**: Collision count  
This 4-bit counter value indicates the number of collisions occurring before the frame was transmitted. The count is not valid when the Excessive collisions bit (TDES0[8]) is set.
- Bit 2 **ED**: Excessive deferral  
When set, this bit indicates that the transmission has ended because of excessive deferral of over 24 288 bit times if the Deferral check (DC) bit in the MAC Control register is set high.
- Bit 1 **UF**: Underflow error  
When set, this bit indicates that the MAC aborted the frame because data arrived late from the RAM memory. Underflow error indicates that the DMA encountered an empty transmit buffer while transmitting the frame. The transmission process enters the Suspended state and sets both Transmit underflow (Register 5[5]) and Transmit interrupt (Register 5[0]).
- Bit 0 **DB**: Deferred bit  
When set, this bit indicates that the MAC defers before transmission because of the presence of the carrier. This bit is valid only in Half-duplex mode.

- **TDES1: Transmit descriptor Word1**

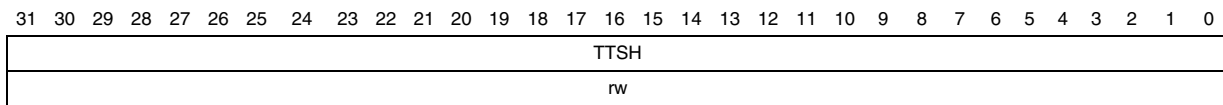
Refer to [TDES1: Transmit descriptor Word1](#) section.

- **TDES2: Transmit descriptor Word2**



- Bits 31:0 **TTSL**: Transmit frame time stamp low  
This field is updated by DMA with the 32 least significant bits of the time stamp captured for the corresponding transmit frame. This field has the time stamp only if the Last segment control bit (LS) in the descriptor is set.

- **TDES3: Transmit descriptor Word3**



Bits 31:0 TTSH: Transmit frame time stamp high

This field is updated by DMA with the 32 most significant bits of the time stamp captured for the corresponding transmit frame. This field has the time stamp only if the Last segment control bit (LS) in the descriptor is set.

## 28.6.8 Rx DMA configuration

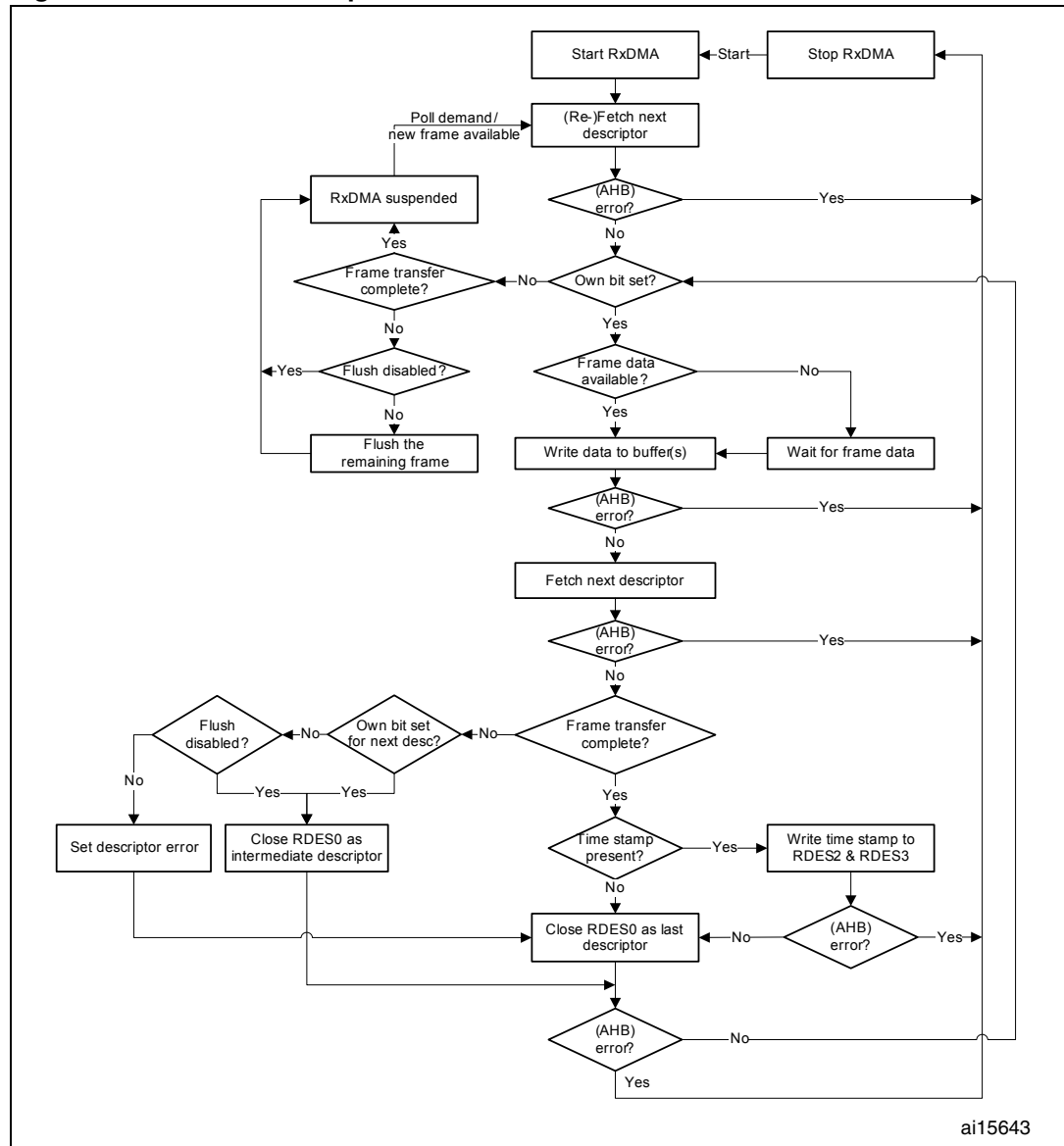
The Receive DMA engine's reception sequence is illustrated in [Figure 356](#) and described below:

1. The CPU sets up Receive descriptors (RDES0-RDES3) and sets the OWN bit (RDES0[31]).
2. Once the SR (ETH\_DMAOMR register[1]) bit is set, the DMA enters the Run state. While in the Run state, the DMA polls the receive descriptor list, attempting to acquire free descriptors. If the fetched descriptor is not free (is owned by the CPU), the DMA enters the Suspend state and jumps to Step 9.
3. The DMA decodes the receive data buffer address from the acquired descriptors.
4. Incoming frames are processed and placed in the acquired descriptor's data buffers.
5. When the buffer is full or the frame transfer is complete, the Receive engine fetches the next descriptor.
6. If the current frame transfer is complete, the DMA proceeds to step 7. If the DMA does not own the next fetched descriptor and the frame transfer is not complete (EOF is not yet transferred), the DMA sets the Descriptor error bit in RDES0 (unless flushing is disabled). The DMA closes the current descriptor (clears the OWN bit) and marks it as intermediate by clearing the Last segment (LS) bit in the RDES1 value (marks it as last descriptor if flushing is not disabled), then proceeds to step 8. If the DMA owns the next descriptor but the current frame transfer is not complete, the DMA closes the current descriptor as intermediate and returns to step 4.
7. If IEEE 1588 time stamping is enabled, the DMA writes the time stamp (if available) to the current descriptor's RDES2 and RDES3. It then takes the received frame's status and writes the status word to the current descriptor's RDES0, with the OWN bit cleared and the Last segment bit set.
8. The Receive engine checks the latest descriptor's OWN bit. If the CPU owns the descriptor (OWN bit is at 0) the Receive buffer unavailable bit (in ETH\_DMASR register[7]) is set and the DMA Receive engine enters the Suspended state (step 9). If the DMA owns the descriptor, the engine returns to step 4 and awaits the next frame.
9. Before the Receive engine enters the Suspend state, partial frames are flushed from the Receive FIFO (you can control flushing using bit 24 in the ETH\_DMAOMR register).
10. The Receive DMA exits the Suspend state when a Receive Poll demand is given or the start of next frame is available from the Receive FIFO. The engine proceeds to step 2 and re-fetches the next descriptor.

The DMA does not acknowledge accepting the status until it has completed the time stamp write-back and is ready to perform status write-back to the descriptor. If software has

enabled time stamping through CSR, when a valid time stamp value is not available for the frame (for example, because the receive FIFO was full before the time stamp could be written to it), the DMA writes all ones to RDES2 and RDES3. Otherwise (that is, if time stamping is not enabled), RDES2 and RDES3 remain unchanged.

Figure 356. Receive DMA operation



### Receive descriptor acquisition

The receive engine always attempts to acquire an extra descriptor in anticipation of an incoming frame. Descriptor acquisition is attempted if any of the following conditions is/are satisfied:

- The receive Start/Stop bit (ETH\_DMAOMR register[1]) has been set immediately after the DMA has been placed in the Run state.
- The data buffer of the current descriptor is full before the end of the frame currently being transferred
- The controller has completed frame reception, but the current receive descriptor has not yet been closed.
- The receive process has been suspended because of a CPU-owned buffer (RDES0[31] = 0) and a new frame is received.
- A Receive poll demand has been issued.

### Receive frame processing

The MAC transfers the received frames to the STM32F107xx memory only when the frame passes the address filter and the frame size is greater than or equal to the configurable threshold bytes set for the Receive FIFO, or when the complete frame is written to the FIFO in Store-and-forward mode. If the frame fails the address filtering, it is dropped in the MAC block itself (unless Receive All ETH\_MACFFR [31] bit is set). Frames that are shorter than 64 bytes, because of collision or premature termination, can be purged from the Receive FIFO. After 64 (configurable threshold) bytes have been received, the DMA block begins transferring the frame data to the receive buffer pointed to by the current descriptor. The DMA sets the first descriptor (RDES0[9]) after the DMA AHB Interface becomes ready to receive a data transfer (if DMA is not fetching transmit data from the memory), to delimit the frame. The descriptors are released when the OWN (RDES0[31]) bit is reset to 0, either as the data buffer fills up or as the last segment of the frame is transferred to the receive buffer. If the frame is contained in a single descriptor, both the last descriptor (RDES0[8]) and first descriptor (RDES0[9]) bits are set. The DMA fetches the next descriptor, sets the last descriptor (RDES0[8]) bit, and releases the RDES0 status bits in the previous frame descriptor. Then the DMA sets the receive interrupt bit (ETH\_DMASR register [6]). The same process repeats unless the DMA encounters a descriptor flagged as being owned by the CPU. If this occurs, the receive process sets the receive buffer unavailable bit (ETH\_DMASR register[7]) and then enters the Suspend state. The position in the receive list is retained.

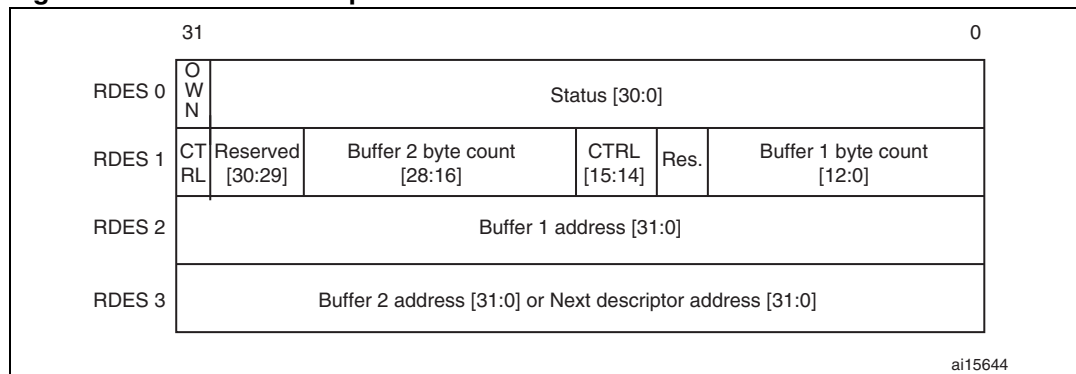
### Receive process suspended

If a new receive frame arrives while the receive process is in Suspend state, the DMA re-fetches the current descriptor in the STM32F107xx memory. If the descriptor is now owned by the DMA, the receive process re-enters the Run state and starts frame reception. If the descriptor is still owned by the host, by default, the DMA discards the current frame at the top of the Rx FIFO and increments the missed frame counter. If more than one frame is stored in the Rx FIFO, the process repeats. The discarding or flushing of the frame at the top of the Rx FIFO can be avoided by setting the DMA Operation mode register bit 24 (DFRF). In such conditions, the receive process sets the receive buffer unavailable status bit and returns to the Suspend state.

### Rx DMA descriptors

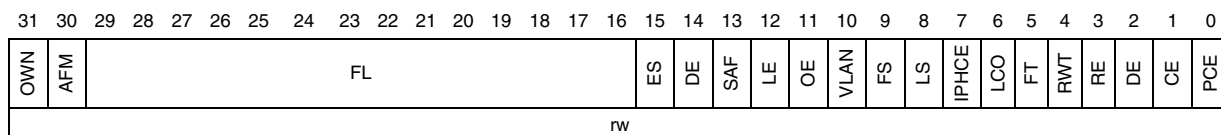
The descriptor structure consists of four 32-bit words (16 bytes). These are shown in [Figure 357](#). The bit descriptions of RDES0, RDES1, RDES2 and RDES3 are given below.

**Figure 357. Rx DMA descriptor structure**



- **RDES0: Receive descriptor Word0**

RDES0 contains the received frame status, the frame length and the descriptor ownership information.



**Bit 31 OWN:** Own bit

When set, this bit indicates that the descriptor is owned by the DMA of the MAC Subsystem. When this bit is reset, it indicates that the descriptor is owned by the Host. The DMA clears this bit either when it completes the frame reception or when the buffers that are associated with this descriptor are full.

**Bit 30 AFM:** Destination address filter fail

When set, this bit indicates a frame that failed the DA filter in the MAC Core.

**Bits 29:16 FL:** Frame length

These bits indicate the byte length of the received frame that was transferred to host memory (including CRC). This field is valid only when last descriptor (RDES0[8]) is set and descriptor error (RDES0[14]) is reset.

This field is valid when last descriptor (RDES0[8]) is set. When the last descriptor and error summary bits are not set, this field indicates the accumulated number of bytes that have been transferred for the current frame.

- Bit 15 **ES**: Error summary  
Indicates the logical OR of the following bits:
- RDES0[1]: CRC error
  - RDES0[3]: Receive error
  - RDES0[4]: Watchdog timeout
  - RDES0[6]: Late collision
  - RDES0[7]: Giant frame (This is not applicable when RDES0[7] indicates an IPV4 header checksum error.)
  - RDES0[11]: Overflow error
  - RDES0[14]: Descriptor error.
- This field is valid only when the last descriptor (RDES0[8]) is set.
- Bit 14 **DE**: Descriptor error  
When set, this bit indicates a frame truncation caused by a frame that does not fit within the current descriptor buffers, and that the DMA does not own the next descriptor. The frame is truncated. This field is valid only when the last descriptor (RDES0[8]) is set.
- Bit 13 **SAF**: Source address filter fail  
When set, this bit indicates that the SA field of frame failed the SA filter in the MAC Core.
- Bit 12 **LE**: Length error  
When set, this bit indicates that the actual length of the received frame does not match the value in the Length/ Type field. This bit is valid only when the Frame type (RDES0[5]) bit is reset.
- Bit 11 **OE**: Overflow error  
When set, this bit indicates that the received frame was damaged due to buffer overflow.
- Bit 10 **VLAN**: VLAN tag  
When set, this bit indicates that the frame pointed to by this descriptor is a VLAN frame tagged by the MAC core.
- Bit 9 **FS**: First descriptor  
When set, this bit indicates that this descriptor contains the first buffer of the frame. If the size of the first buffer is 0, the second buffer contains the beginning of the frame. If the size of the second buffer is also 0, the next descriptor contains the beginning of the frame.
- Bit 8 **LS**: Last descriptor  
When set, this bit indicates that the buffers pointed to by this descriptor are the last buffers of the frame.
- Bit 7 **IPHCE**: IPv header checksum error  
If IPHCE is set, it indicates an error in the IPv4 or IPv6 header. This error can be due to inconsistent Ethernet Type field and IP header Version field values, a header checksum mismatch in IPv4, or an Ethernet frame lacking the expected number of IP header bytes.
- Bit 6 **LCO**: Late collision  
When set, this bit indicates that a late collision has occurred while receiving the frame in Half-duplex mode.
- Bit 5 **FT**: Frame type  
When set, this bit indicates that the Receive frame is an Ethernet-type frame (the LT field is greater than or equal to 0x0600). When this bit is reset, it indicates that the received frame is an IEEE802.3 frame. This bit is not valid for Runt frames less than 14 bytes.
- Bit 4 **RWT**: Receive watchdog timeout  
When set, this bit indicates that the Receive watchdog timer has expired while receiving the current frame and the current frame is truncated after the watchdog timeout.

Bit 3 **RE**: Receive error

When set, this bit indicates that the RX\_ERR signal is asserted while RX\_DV is asserted during frame reception.

Bit 2 **DE**: Dribble bit error

When set, this bit indicates that the received frame has a non-integer multiple of bytes (odd nibbles). This bit is valid only in MII mode.

Bit 1 **CE**: CRC error

When set, this bit indicates that a cyclic redundancy check (CRC) error occurred on the received frame. This field is valid only when the last descriptor (RDES0[8]) is set.

Bit 0 **PCE**: Payload checksum error

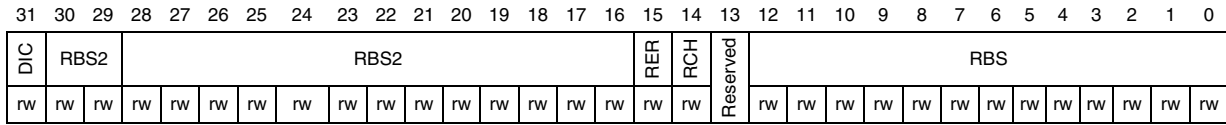
When set, it indicates that the TCP, UDP or ICMP checksum the core calculated does not match the received encapsulated TCP, UDP or ICMP segment's Checksum field. This bit is also set when the received number of payload bytes does not match the value indicated in the Length field of the encapsulated IPv4 or IPv6 datagram in the received Ethernet frame.

Bits 5, 7, and 0 reflect the conditions discussed in [Table 211](#).

**Table 211. Receive descriptor 0**

Bit 5: frame type	Bit 7: IPC checksum error	Bit 0: payload checksum error	Frame status
0	0	0	IEEE 802.3 Type frame (Length field value is less than 0x0600.)
1	0	0	IPv4/IPv6 Type frame, no checksum error detected
1	0	1	IPv4/IPv6 Type frame with a payload checksum error (as described for PCE) detected
1	1	0	IPv4/IPv6 Type frame with an IP header checksum error (as described for IPC CE) detected
1	1	1	IPv4/IPv6 Type frame with both IP header and payload checksum errors detected
0	0	1	IPv4/IPv6 Type frame with no IP header checksum error and the payload check bypassed, due to an unsupported payload
0	1	1	A Type frame that is neither IPv4 or IPv6 (the checksum offload engine bypasses checksum completely.)
0	1	0	Reserved

● **RDES1: Receive descriptor Word1**



**Bit 31 DIC:** Disable interrupt on completion  
 When set, this bit prevents setting the Status register's RS bit (CSR5[6]) for the received frame ending in the buffer indicated by this descriptor. This, in turn, disables the assertion of the interrupt to Host due to RS for that frame.

Bits 30:29 Reserved

**Bits 28:16 RBS2:** Receive buffer 2 size  
 These bits indicate the second data buffer size, in bytes. The buffer size must be a multiple of 4, 8, or 16, depending on the bus widths (32, 64 or 128, respectively), even if the value of RDES3 (buffer2 address pointer) is not aligned to bus width. If the buffer size is not an appropriate multiple of 4, 8 or 16, the resulting behavior is undefined. This field is not valid if RDES1 [14] is set.

**Bit 15 RER:** Receive end of ring  
 When set, this bit indicates that the descriptor list reached its final descriptor. The DMA returns to the base address of the list, creating a descriptor ring.

**Bit 14 RCH:** Second address chained  
 When set, this bit indicates that the second address in the descriptor is the next descriptor address rather than the second buffer address. When this bit is set, RBS2 (RDES1[28:16]) is a "don't care" value. RDES1[15] takes precedence over RDES1[14].

Bit 13 Reserved

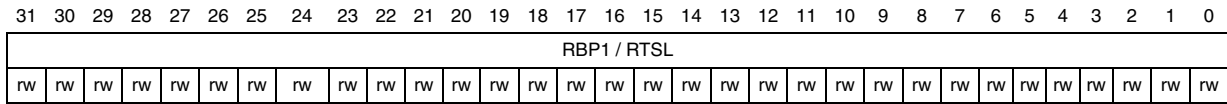
**Bits 12:0 RBS1:** Receive buffer 1 size  
 Indicates the first data buffer size in bytes. The buffer size must be a multiple of 4, 8 or 16, depending upon the bus widths (32, 64 or 128), even if the value of RDES2 (buffer1 address pointer) is not aligned. When the buffer size is not a multiple of 4, 8 or 16, the resulting behavior is undefined. If this field is 0, the DMA ignores this buffer and uses Buffer 2 or next descriptor depending on the value of RCH (bit 14).





- **RDES2: Receive descriptor Word2**

RDES2 contains the address pointer to the first data buffer in the descriptor, or it contains time stamp data.



Bits 31:0 **RBAP1 / RTSL**: Receive buffer 1 address pointer / Receive frame time stamp low

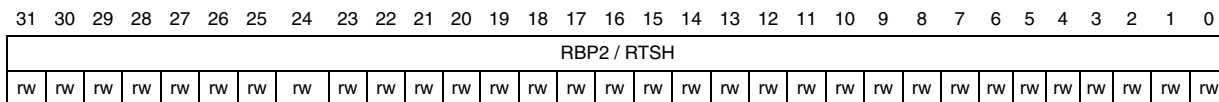
These bits take on two different functions: the application uses them to indicate to the DMA where to store the data in memory, and then after transferring all the data the DMA may use these bits to pass back time stamp data.

**RBAP1**: When the software makes this descriptor available to the DMA (at the moment that the OWN bit is set to 1 in RDES0), these bits indicate the physical address of Buffer 1. There are no limitations on the buffer address alignment except for the following condition: the DMA uses the configured value for its address generation when the RDES2 value is used to store the start of frame. Note that the DMA performs a write operation with the RDES2[3/2/1:0] bits as 0 during the transfer of the start of frame but the frame data is shifted as per the actual Buffer address pointer. The DMA ignores RDES2[3/2/1:0] (corresponding to bus width of 128/64/32) if the address pointer is to a buffer where the middle or last part of the frame is stored.

**RTSL**: Before it clears the OWN bit in RDES0, the DMA updates this field with the 32 least significant bits of the time stamp captured for the corresponding receive frame (overwriting the value for RBAP1). This field has the time stamp only if time stamping is activated for this frame and if the Last segment control bit (LS) in the descriptor is set.

● **RDES3: Receive descriptor Word3**

RDES3 contains the address pointer either to the second data buffer in the descriptor or to the next descriptor, or it contains time stamp data.



Bits 31:0 **RBAP2 / RTSH:** Receive buffer 2 address pointer (next descriptor address) / Receive frame time stamp high

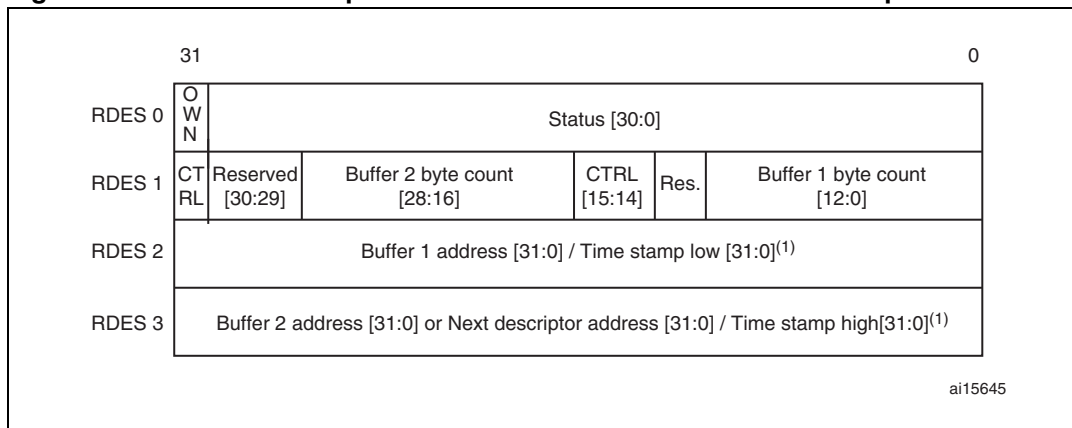
These bits take on two different functions: the application uses them to indicate to the DMA the location of where to store the data in memory, and then after transferring all the data the DMA may use these bits to pass back time stamp data.

**RBAP1:** When the software makes this descriptor available to the DMA (at the moment that the OWN bit is set to 1 in RDES0), these bits indicate the physical address of buffer 2 when a descriptor ring structure is used. If the second address chained (RDES1 [24]) bit is set, this address contains the pointer to the physical memory where the next descriptor is present. If RDES1 [24] is set, the buffer (next descriptor) address pointer must be bus width-aligned (RDES3[3, 2, or 1:0] = 0, corresponding to a bus width of 128, 64 or 32. LSBs are ignored internally.) However, when RDES1 [24] is reset, there are no limitations on the RDES3 value, except for the following condition: the DMA uses the configured value for its buffer address generation when the RDES3 value is used to store the start of frame. The DMA ignores RDES3[3, 2, or 1:0] (corresponding to a bus width of 128, 64 or 32) if the address pointer is to a buffer where the middle or last part of the frame is stored.

**RTSH:** Before it clears the OWN bit in RDES0, the DMA updates this field with the 32 most significant bits of the time stamp captured for the corresponding receive frame (overwriting the value for RBAP2). This field has the time stamp only if time stamping is activated and if the Last segment control bit (LS) in the descriptor is set.

**Rx DMA descriptor format with IEEE1588 time stamp**

**Figure 358. Receive descriptor fields format with IEEE1588 time stamp enabled**



1. The DMA updates RDES2 and RDES3 with the time stamp value before clearing the OWN bit in RDES0: RDES2 is updated with the lower 32 time stamp bits (the sub-second field, called RTSL in the *RDES2: Receive descriptor Word2* section) and RDES3 is updated with the upper 32 time stamp bits (the Seconds field, called RTSH in the *RDES3: Receive descriptor Word3* section).

- **RDES0: Receive descriptor Word0**  
Refer to [RDES0: Receive descriptor Word0](#) section
- **RDES1: Receive descriptor Word1**  
Refer to [RDES1: Receive descriptor Word1](#) section
- **RDES2: Receive descriptor Word2**  
The table below describes the fields that have different meaning for RDES2 when the receive descriptor is closed and time stamping is enabled.

31	30	29	28	27	26	25	24	23	22	21	20	19	18	17	16	15	14	13	12	11	10	9	8	7	6	5	4	3	2	1	0	
RTSL																																
rw	rw	rw	rw	rw	rw	rw	rw	rw	rw	rw	rw	rw	rw	rw	rw	rw	rw	rw	rw	rw	rw	rw	rw	rw	rw	rw	rw	rw	rw	rw	rw	rw

Bits 31:0 **RTSL**: Receive frame time stamp low  
 The DMA updates this field with the 32 least significant bits of the time stamp captured for the corresponding receive frame. The DMA updates this field only for the last descriptor of the receive frame indicated by last descriptor status bit (RDES0[8]). When this field and the RTSH field in RDES3 show all ones, the time stamp must be treated as corrupt.

- **RDES3: Receive descriptor Word3**  
The table below describes the fields that have different meaning for RDES3 when the receive descriptor is closed and time stamping is enabled.

31	30	29	28	27	26	25	24	23	22	21	20	19	18	17	16	15	14	13	12	11	10	9	8	7	6	5	4	3	2	1	0	
RTSH																																
rw	rw	rw	rw	rw	rw	rw	rw	rw	rw	rw	rw	rw	rw	rw	rw	rw	rw	rw	rw	rw	rw	rw	rw	rw	rw	rw	rw	rw	rw	rw	rw	rw

Bits 31:0 **RTSH**: Receive frame time stamp high  
 The DMA updates this field with the 32 most significant bits of the time stamp captured for the corresponding receive frame. The DMA updates this field only for the last descriptor of the receive frame indicated by last descriptor status bit (RDES0[8]).  
 When this field and RDES2's RTSL field show all ones, the time stamp must be treated as corrupt.

### 28.6.9 DMA interrupts

Interrupts can be generated as a result of various events. The ETH\_DMASR register contains all the bits that might cause an interrupt. The ETH\_DMAIER register contains an enable bit for each of the events that can cause an interrupt.

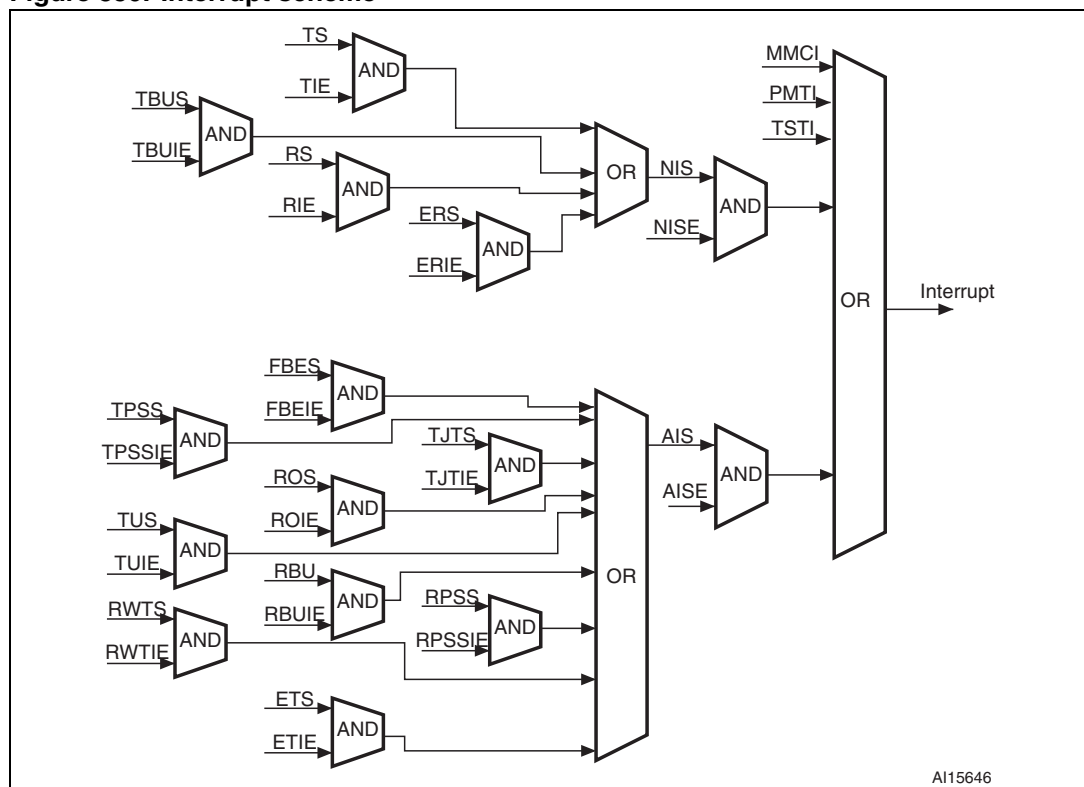
There are two groups of interrupts, Normal and Abnormal, as described in the ETH\_DMASR register. Interrupts are cleared by writing a 1 to the corresponding bit position. When all the enabled interrupts within a group are cleared, the corresponding summary bit is cleared. If the MAC core is the cause for assertion of the interrupt, then any of the TSTS or PMTS bits in the ETH\_DMASR register is set high.

Interrupts are not queued and if the interrupt event occurs before the driver has responded to it, no additional interrupts are generated. For example, the Receive Interrupt bit (ETH\_DMASR register [6]) indicates that one or more frames were transferred to the

STM32F107xx buffer. The driver must scan all descriptors, from the last recorded position to the first one owned by the DMA.

An interrupt is generated only once for simultaneous, multiple events. The driver must scan the ETH\_DMASR register for the cause of the interrupt. The interrupt is not generated again unless a new interrupting event occurs, after the driver has cleared the appropriate bit in the ETH\_DMASR register. For example, the controller generates a Receive interrupt (ETH\_DMASR register[6]) and the driver begins reading the ETH\_DMASR register. Next, receive buffer unavailable (ETH\_DMASR register[7]) occurs. The driver clears the Receive interrupt. Even then, a new interrupt is generated, due to the active or pending Receive buffer unavailable interrupt.

Figure 359. Interrupt scheme



## 28.7 Ethernet interrupts

The Ethernet controller has two interrupt vectors: one dedicated to normal Ethernet operations and the other, used only for the Ethernet wakeup event (with wakeup frame or Magic Packet detection) when it is mapped on EXTI line19.

The first Ethernet vector is reserved for interrupts generated by the MAC and the DMA as listed in the [MAC interrupts](#) and [DMA interrupts](#) sections.

The second vector is reserved for interrupts generated by the PMT on wakeup events. The mapping of a wakeup event on EXTI line19 causes the STM32F107xx to exit the low power mode, and generates an interrupt.

When an Ethernet wakeup event mapped on EXTI Line19 occurs and the MAC PMT interrupt is enabled and the EXTI Line19 interrupt, with detection on rising edge, is also enabled, both interrupts are generated.

A watchdog timer (see ETH\_DMARSWTR register) is given for flexible control of the RS bit (ETH\_DMASR register). When this watchdog timer is programmed with a non-zero value, it gets activated as soon as the RxDMA completes a transfer of a received frame to system memory without asserting the Receive Status because it is not enabled in the corresponding Receive descriptor (RDES1[31]). When this timer runs out as per the programmed value, the RS bit is set and the interrupt is asserted if the corresponding RIE is enabled in the ETH\_DMAIER register. This timer is disabled before it runs out, when a frame is transferred to memory and the RS is set because it is enabled for that descriptor.

*Note: Reading the PMT control and status register automatically clears the Wakeup Frame Received and Magic Packet Received PMT interrupt flags. However, since the registers for these flags are in the CLK\_RX domain, there may be a significant delay before this update is visible by the firmware. The delay is especially long when the RX clock is slow (in 10 Mbit mode) and when the AHB bus is high-frequency. Since interrupt requests from the PMT to the CPU are based on the same registers in the CLK\_RX domain, the CPU may spuriously call the interrupt routine a second time even after reading PMT\_CSR. Thus, it may be necessary that the firmware polls the Wakeup Frame Received and Magic Packet Received bits and exits the interrupt service routine only when they are found to be at '0'.*

## 28.8 Ethernet register descriptions

The peripheral registers can be accessed by bytes (8-bit), half-words (16-bit) or words (32-bits).

### 28.8.1 MAC register description

#### Ethernet MAC configuration register (ETH\_MACCR)

Address offset: 0x0000

Reset value: 0x0000 8000

The MAC configuration register is the operation mode register of the MAC. It establishes receive and transmit operating modes.

31	30	29	28	27	26	25	24	23	22	21	20	19	18	17	16	15	14	13	12	11	10	9	8	7	6	5	4	3	2	1	0
Reserved								WD	JD	Reserved			IFG	CSD	Reserved	FES	ROD	LM	DM	IPCO	RD	Reserved	APCS	BL	DC	TE	RE	Reserved			
								rw	rw				rw	rw		rw	rw	rw	rw	rw	rw		rw	rw	rw	rw	rw				

Bits 31:24 Reserved

Bit 23 **WD**: Watchdog disable

When this bit is set, the MAC disables the watchdog timer on the receiver, and can receive frames of up to 16 384 bytes.

When this bit is reset, the MAC allows no more than 2 048 bytes of the frame being received and cuts off any bytes received after that.

Bit 22 **JD**: Jabber disable

When this bit is set, the MAC disables the jabber timer on the transmitter, and can transfer frames of up to 16 384 bytes.

When this bit is reset, the MAC cuts off the transmitter if the application sends out more than 2 048 bytes of data during transmission.

Bits 21:20 Reserved

Bits 19:17 **IFG**: Interframe gap

These bits control the minimum interframe gap between frames during transmission.

000: 96 bit times

001: 88 bit times

010: 80 bit times

....

111: 40 bit times

*Note: In Half-duplex mode, the minimum IFG can be configured for 64 bit times (IFG = 100) only. Lower values are not considered.*

Bit 16 **CSD**: Carrier sense disable

When set high, this bit makes the MAC transmitter ignore the MII CRS signal during frame transmission in Half-duplex mode. No error is generated due to Loss of Carrier or No Carrier during such transmission.

When this bit is low, the MAC transmitter generates such errors due to Carrier Sense and even aborts the transmissions.

Bit 15 Reserved

Bit 14 **FES**: Fast Ethernet speed

Indicates the speed in Fast Ethernet (MII) mode:

0: 10 Mbit/s

1: 100 Mbit/s

Bit 13 **ROD**: Receive own disable

When this bit is set, the MAC disables the reception of frames in Half-duplex mode.

When this bit is reset, the MAC receives all packets that are given by the PHY while transmitting.

This bit is not applicable if the MAC is operating in Full-duplex mode.

Bit 12 **LM**: Loopback mode

When this bit is set, the MAC operates in loopback mode at the MII. The MII receive clock input (RX\_CLK) is required for the loopback to work properly, as the transmit clock is not looped-back internally.

Bit 11 **DM**: Duplex mode

When this bit is set, the MAC operates in a Full-duplex mode where it can transmit and receive simultaneously.

Bit 10 **IPCO**: IPv4 checksum offload

When set, this bit enables IPv4 checksum checking for received frame payloads' TCP/UDP/ICMP headers. When this bit is reset, the checksum offload function in the receiver is disabled and the corresponding PCE and IP HCE status bits (see [Table 208 on page 937](#)) are always cleared.

Bit 9 **RD**: Retry disable

When this bit is set, the MAC attempts only 1 transmission. When a collision occurs on the MII, the MAC ignores the current frame transmission and reports a Frame Abort with excessive collision error in the transmit frame status.

When this bit is reset, the MAC attempts retries based on the settings of BL.

*Note: This bit is applicable only in the Half-duplex mode.*

## Bit 8 Reserved

Bit 7 **APCS**: Automatic pad/CRC stripping

When this bit is set, the MAC strips the Pad/FCS field on incoming frames only if the length's field value is less than or equal to 1 500 bytes. All received frames with length field greater than or equal to 1 501 bytes are passed on to the application without stripping the Pad/FCS field.

When this bit is reset, the MAC passes all incoming frames unmodified.

Bits 6:5 **BL**: Back-off limit

The Back-off limit determines the random integer number ( $r$ ) of slot time delays (4 096 bit times for 1000 Mbit/s and 512 bit times for 10/100 Mbit/s) the MAC waits before rescheduling a transmission attempt during retries after a collision.

*Note: This bit is applicable only to Half-duplex mode.*

00:  $k = \min(n, 10)$

01:  $k = \min(n, 8)$

10:  $k = \min(n, 4)$

11:  $k = \min(n, 1)$ ,

where  $n$  = retransmission attempt. The random integer  $r$  takes the value in the range  $0 \leq r < 2^k$

Bit 4 **DC**: Deferral check

When this bit is set, the deferral check function is enabled in the MAC. The MAC issues a Frame Abort status, along with the excessive deferral error bit set in the transmit frame status when the transmit state machine is deferred for more than 24 288 bit times in 10/100-Mbit/s mode. Deferral begins when the transmitter is ready to transmit, but is prevented because of an active CRS (carrier sense) signal on the MII. Defer time is not cumulative. If the transmitter defers for 10 000 bit times, then transmits, collides, backs off, and then has to defer again after completion of back-off, the deferral timer resets to 0 and restarts.

When this bit is reset, the deferral check function is disabled and the MAC defers until the CRS signal goes inactive. This bit is applicable only in Half-duplex mode.

Bit 3 **TE**: Transmitter enable

When this bit is set, the transmit state machine of the MAC is enabled for transmission on the MII. When this bit is reset, the MAC transmit state machine is disabled after the completion of the transmission of the current frame, and does not transmit any further frames.

Bit 2 **RE**: Receiver enable

When this bit is set, the receiver state machine of the MAC is enabled for receiving frames from the MII. When this bit is reset, the MAC receive state machine is disabled after the completion of the reception of the current frame, and will not receive any further frames from the MII.

## Bits 1:0 Reserved

**Ethernet MAC frame filter register (ETH\_MACFFR)**

Address offset: 0x0004  
 Reset value: 0x0000 0000

The MAC frame filter register contains the filter controls for receiving frames. Some of the controls from this register go to the address check block of the MAC, which performs the first level of address filtering. The second level of filtering is performed on the incoming frame, based on other controls such as pass bad frames and pass control frames.

31	30	29	28	27	26	25	24	23	22	21	20	19	18	17	16	15	14	13	12	11	10	9	8	7	6	5	4	3	2	1	0
RA	Reserved																				HPF	SAF	SAIF	PCF	BFD	PAM	DAIF	HM	HU	PM	
rw																					rw	rw	rw	rw	rw	rw	rw	rw	rw	rw	

Bit 31 **RA**: Receive all  
 When this bit is set, the MAC receiver passes all received frames on to the application, irrespective of whether they have passed the address filter. The result of the SA/DA filtering is updated (pass or fail) in the corresponding bits in the receive status word. When this bit is reset, the MAC receiver passes on to the application only those frames that have passed the SA/DA address filter.

Bits 30:11 Reserved

Bit 10 **HPF**: Hash or perfect filter  
 When this bit is set and if the HM or HU bit is set, the address filter passes frames that match either the perfect filtering or the hash filtering.  
 When this bit is cleared and if the HU or HM bit is set, only frames that match the Hash filter are passed.

Bit 9 **SAF**: Source address filter  
 The MAC core compares the SA field of the received frames with the values programmed in the enabled SA registers. If the comparison matches, then the SAMatch bit in the RxStatus word is set high. When this bit is set high and the SA filter fails, the MAC drops the frame. When this bit is reset, the MAC core forwards the received frame to the application. It also forwards the updated SA Match bit in RxStatus depending on the SA address comparison.

Bit 8 **SAIF**: Source address inverse filtering  
 When this bit is set, the address check block operates in inverse filtering mode for the SA address comparison. The frames whose SA matches the SA registers are marked as failing the SA address filter.  
 When this bit is reset, frames whose SA does not match the SA registers are marked as failing the SA address filter.

Bits 7:6 **PCF**: Pass control frames  
 These bits control the forwarding of all control frames (including unicast and multicast PAUSE frames). Note that the processing of PAUSE control frames depends only on RFCE in Flow Control Register[2].  
 00 or 01: MAC prevents all control frames from reaching the application  
 10: MAC forwards all control frames to application even if they fail the address filter  
 11: MAC forwards control frames that pass the address filter.

Bit 5 **BFD**: Broadcast frames disable  
 When this bit is set, the address filters filter all incoming broadcast frames.  
 When this bit is reset, the address filters pass all received broadcast frames.



- Bit 4 **PAM**: Pass all multicast  
 When set, this bit indicates that all received frames with a multicast destination address (first bit in the destination address field is '1') are passed.  
 When reset, filtering of multicast frame depends on the HM bit.
- Bit 3 **DAIF**: Destination address inverse filtering  
 When this bit is set, the address check block operates in inverse filtering mode for the DA address comparison for both unicast and multicast frames.  
 When reset, normal filtering of frames is performed.
- Bit 2 **HM**: Hash multicast  
 When set, MAC performs destination address filtering of received multicast frames according to the hash table.  
 When reset, the MAC performs a perfect destination address filtering for multicast frames, that is, it compares the DA field with the values programmed in DA registers.
- Bit 1 **HU**: Hash unicast  
 When set, MAC performs destination address filtering of unicast frames according to the hash table.  
 When reset, the MAC performs a perfect destination address filtering for unicast frames, that is, it compares the DA field with the values programmed in DA registers.
- Bit 0 **PM**: Promiscuous mode  
 When this bit is set, the address filters pass all incoming frames regardless of their destination or source address. The SA/DA filter fails status bits in the receive status word are always cleared when PM is set.

### Ethernet MAC hash table high register (ETH\_MACHTHR)

Address offset: 0x0008

Reset value: 0x0000 0000

The 64-bit Hash table is used for group address filtering. For hash filtering, the contents of the destination address in the incoming frame are passed through the CRC logic, and the upper 6 bits in the CRC register are used to index the contents of the Hash table. This CRC is a 32-bit value coded by the following polynomial (for more details refer to [Section 28.5.3: MAC frame reception](#)):

$$G(x) = x^{32} + x^{26} + x^{23} + x^{22} + x^{16} + x^{12} + x^{11} + x^{10} + x^8 + x^7 + x^5 + x^4 + x^2 + x + 1$$

The most significant bit determines the register to be used (hash table high/hash table low), and the other 5 bits determine which bit within the register. A hash value of 0b0 0000 selects bit 0 in the selected register, and a value of 0b1 1111 selects bit 31 in the selected register.

For example, if the DA of the incoming frame is received as 0x1F52 419C B6AF (0x1F is the first byte received on the MII interface), then the internally calculated 6-bit Hash value is 0x2C and the HTH register bit[12] is checked for filtering. If the DA of the incoming frame is received as 0xA00A 9800 0045, then the calculated 6-bit Hash value is 0x07 and the HTL register bit[7] is checked for filtering.

If the corresponding bit value in the register is 1, the frame is accepted. Otherwise, it is rejected. If the PAM (pass all multicast) bit is set in the ETH\_MACFFR register, then all multicast frames are accepted regardless of the multicast hash values.

The Hash table high register contains the higher 32 bits of the multicast Hash table.

31	30	29	28	27	26	25	24	23	22	21	20	19	18	17	16	15	14	13	12	11	10	9	8	7	6	5	4	3	2	1	0	
HTH																																
rw	rw	rw	rw	rw	rw	rw	rw	rw	rw	rw	rw	rw	rw	rw	rw	rw	rw	rw	rw	rw	rw	rw	rw	rw	rw	rw	rw	rw	rw	rw	rw	rw

Bits 31:0 **HTH**: Hash table high  
 This field contains the upper 32 bits of Hash table.

**Ethernet MAC hash table low register (ETH\_MACHTLR)**

Address offset: 0x000C

Reset value: 0x0000 0000

The Hash table low register contains the lower 32 bits of the multi-cast Hash table.

31	30	29	28	27	26	25	24	23	22	21	20	19	18	17	16	15	14	13	12	11	10	9	8	7	6	5	4	3	2	1	0
HTL																															
rw	rw	rw	rw	rw	rw	rw	rw	rw	rw	rw	rw	rw	rw	rw	rw	rw	rw	rw	rw	rw	rw	rw	rw	rw	rw	rw	rw	rw	rw	rw	rw

Bits 31:0 **HTL**: Hash table low  
 This field contains the lower 32 bits of the Hash table.

**Ethernet MAC MII address register (ETH\_MACMIAR)**

Address offset: 0x0010

Reset value: 0x0000 0000

The MII address register controls the management cycles to the external PHY through the management interface.

31	30	29	28	27	26	25	24	23	22	21	20	19	18	17	16	15	14	13	12	11	10	9	8	7	6	5	4	3	2	1	0
Reserved																PA					MR					Reserved	CR			MW	MB
																rw	rw	rw	rw	rw	rw	rw	rw	rw	rw		rw	rw	rw	rw	rw

Bits 31:16 Reserved

Bits 15:11 **PA**: PHY address  
 This field tells which of the 32 possible PHY devices are being accessed.

Bits 10:6 **MR**: MII register  
 These bits select the desired MII register in the selected PHY device.

Bit 5 Reserved



Bits 4:2 **CR:** Clock range

The CR clock range selection determines the HCLK frequency and is used to decide the frequency of the MDC clock:

Selection	HCLK	MDC Clock
000	60-72 MHz	HCLK/42
001	Reserved	-
010	20-35 MHz	HCLK/16
011	35-60 MHz	HCLK/26
100, 101, 110, 111	Reserved	-

Bit 1 **MW:** MII write

When set, this bit tells the PHY that this will be a Write operation using the MII Data register. If this bit is not set, this will be a Read operation, placing the data in the MII Data register.

Bit 0 **MB:** MII busy

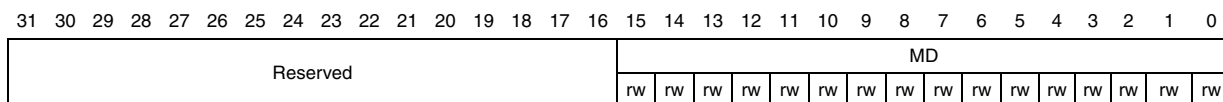
This bit should read a logic 0 before writing to ETH\_MACMIAR and ETH\_MACMIIDR. This bit must also be reset to 0 during a Write to ETH\_MACMIAR. During a PHY register access, this bit is set to 0b1 by the application to indicate that a read or write access is in progress. ETH\_MACMIIDR (MII Data) should be kept valid until this bit is cleared by the MAC during a PHY Write operation. The ETH\_MACMIIDR is invalid until this bit is cleared by the MAC during a PHY Read operation. The ETH\_MACMIAR (MII Address) should not be written to until this bit is cleared.

**Ethernet MAC MII data register (ETH\_MACMIIDR)**

Address offset: 0x0014

Reset value: 0x0000 0000

The MAC MII Data register stores write data to be written to the PHY register located at the address specified in ETH\_MACMIAR. ETH\_MACMIIDR also stores read data from the PHY register located at the address specified by ETH\_MACMIAR.



Bits 31:16 Reserved

Bits 15:0 **MD:** MII data

This contains the 16-bit data value read from the PHY after a Management Read operation, or the 16-bit data value to be written to the PHY before a Management Write operation.

**Ethernet MAC flow control register (ETH\_MACFCR)**

Address offset: 0x0018

Reset value: 0x0000 0000

The Flow control register controls the generation and reception of the control (Pause Command) frames by the MAC. A write to a register with the Busy bit set to '1' causes the MAC to generate a pause control frame. The fields of the control frame are selected as specified in the 802.3x specification, and the Pause Time value from this register is used in the Pause Time field of the control frame. The Busy bit remains set until the control frame is

transferred onto the cable. The Host must make sure that the Busy bit is cleared before writing to the register.

31	30	29	28	27	26	25	24	23	22	21	20	19	18	17	16	15	14	13	12	11	10	9	8	7	6	5	4	3	2	1	0			
PT																Reserved						ZQPD	Reserved	PLT		UPFD	RFCE	TFCE	FCB/BPA					
rw	rw	rw	rw	rw	rw	rw	rw	rw	rw	rw	rw	rw	rw	rw	rw										rw	Reserved	rw	rw	rw	rw	rw	rw	rw	rc_w1/rw

**Bits 31:16 PT: Pause time**

This field holds the value to be used in the Pause Time field in the transmit control frame. If the Pause Time bits is configured to be double-synchronized to the MII clock domain, then consecutive write operations to this register should be performed only after at least 4 clock cycles in the destination clock domain.

**Bits 15:8 Reserved**

**Bit 7 ZQPD: Zero-quanta pause disable**

When set, this bit disables the automatic generation of Zero-quanta pause control frames on the deassertion of the flow-control signal from the FIFO layer.

When this bit is reset, normal operation with automatic Zero-quanta pause control frame generation is enabled.

**Bit 6 Reserved**

**Bits 5:4 PLT: Pause low threshold**

This field configures the threshold of the Pause timer at which the Pause frame is automatically retransmitted. The threshold values should always be less than the Pause Time configured in bits[31:16]. For example, if PT = 100H (256 slot-times), and PLT = 01, then a second PAUSE frame is automatically transmitted if initiated at 228 (256 – 28) slot-times after the first PAUSE frame is transmitted.

Selection	Threshold
00	Pause time minus 4 slot times
01	Pause time minus 28 slot times
10	Pause time minus 144 slot times
11	Pause time minus 256 slot times

Slot time is defined as time taken to transmit 512 bits (64 bytes) on the MII interface.

**Bit 3 UPFD: Unicast pause frame detect**

When this bit is set, the MAC detects the Pause frames with the station’s unicast address specified in the ETH\_MACA0HR and ETH\_MACA0LR registers, in addition to detecting Pause frames with the unique multicast address.

When this bit is reset, the MAC detects only a Pause frame with the unique multicast address specified in the 802.3x standard.

**Bit 2 RFCE: Receive flow control enable**

When this bit is set, the MAC decodes the received Pause frame and disables its transmitter for a specified (Pause Time) time.

When this bit is reset, the decode function of the Pause frame is disabled.

**Bit 1 TFCE: Transmit flow control enable**

In Full-duplex mode, when this bit is set, the MAC enables the flow control operation to transmit Pause frames. When this bit is reset, the flow control operation in the MAC is disabled, and the MAC does not transmit any Pause frames.

In Half-duplex mode, when this bit is set, the MAC enables the back-pressure operation. When this bit is reset, the back pressure feature is disabled.

Bit 0 **FCB/BPA**: Flow control busy/back pressure activate

This bit initiates a Pause Control frame in Full-duplex mode and activates the back pressure function in Half-duplex mode if TFCE bit is set.

In Full-duplex mode, this bit should be read as 0 before writing to the Flow control register. To initiate a Pause control frame, the Application must set this bit to 1. During a transfer of the Control frame, this bit continues to be set to signify that a frame transmission is in progress. After completion of the Pause control frame transmission, the MAC resets this bit to 0. The Flow control register should not be written to until this bit is cleared.

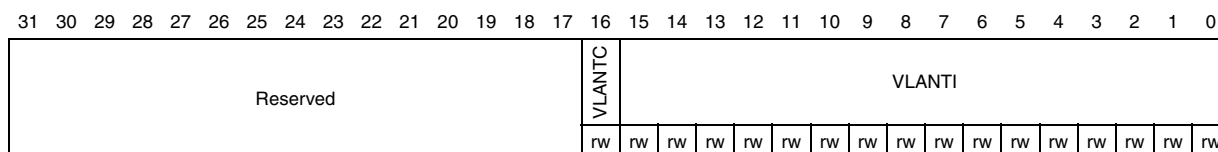
In Half-duplex mode, when this bit is set (and TFCE is set), back pressure is asserted by the MAC core. During back pressure, when the MAC receives a new frame, the transmitter starts sending a JAM pattern resulting in a collision. When the MAC is configured to Full-duplex mode, the BPA is automatically disabled.

**Ethernet MAC VLAN tag register (ETH\_MACVLANTR)**

Address offset: 0x001C

Reset value: 0x0000 0000

The VLAN tag register contains the IEEE 802.1Q VLAN Tag to identify the VLAN frames. The MAC compares the 13<sup>th</sup> and 14<sup>th</sup> bytes of the receiving frame (Length/Type) with 0x8100, and the following 2 bytes are compared with the VLAN tag; if a match occurs, the received VLAN bit in the receive frame status is set. The legal length of the frame is increased from 1518 bytes to 1522 bytes.



Bits 31:17 Reserved

Bit 16 **VLANTC**: 12-bit VLAN tag comparison

When this bit is set, a 12-bit VLAN identifier, rather than the complete 16-bit VLAN tag, is used for comparison and filtering. Bits[11:0] of the VLAN tag are compared with the corresponding field in the received VLAN-tagged frame.

When this bit is reset, all 16 bits of the received VLAN frame’s fifteenth and sixteenth bytes are used for comparison.

Bits 15:0 **VLANTI**: VLAN tag identifier (for receive frames)

This contains the 802.1Q VLAN tag to identify VLAN frames, and is compared to the fifteenth and sixteenth bytes of the frames being received for VLAN frames. Bits[15:13] are the user priority, Bit[12] is the canonical format indicator (CFI) and bits[11:0] are the VLAN tag’s VLAN identifier (VID) field. When the VLANTC bit is set, only the VID (bits[11:0]) is used for comparison.

If VLANTI (VLANTI[11:0] if VLANTC is set) is all zeros, the MAC does not check the fifteenth and sixteenth bytes for VLAN tag comparison, and declares all frames with a Type field value of 0x8100 as VLAN frames.

**Ethernet MAC remote wakeup frame filter register (ETH\_MACRWUFR)**

Address offset: 0x0028

Reset value: 0x0000 0000

This is the address through which the remote wakeup frame filter registers are written/read by the application. The Wakeup frame filter register is actually a pointer to eight (not transparent) such wakeup frame filter registers. Eight sequential write operations to this address with the offset (0x0028) will write all wakeup frame filter registers. Eight sequential read operations from this address with the offset (0x0028) will read all wakeup frame filter registers. This register contains the higher 16 bits of the 7<sup>th</sup> MAC address. Refer to [Remote wakeup frame filter register](#) section for additional information.

**Figure 360. Ethernet MAC remote wakeup frame filter register (ETH\_MACRWUFR)**

Wakeup frame filter reg0	Filter 0 Byte Mask							
Wakeup frame filter reg1	Filter 1 Byte Mask							
Wakeup frame filter reg2	Filter 2 Byte Mask							
Wakeup frame filter reg3	Filter 3 Byte Mask							
Wakeup frame filter reg4	RSVD	Filter 3 Command	RSVD	Filter 2 Command	RSVD	Filter 1 Command	RSVD	Filter 0 Command
Wakeup frame filter reg5	Filter 3 Offset		Filter 2 Offset		Filter 1 Offset		Filter 0 Offset	
Wakeup frame filter reg6	Filter 1 CRC - 16				Filter 0 CRC - 16			
Wakeup frame filter reg7	Filter 3 CRC - 16				Filter 2 CRC - 16			

ai15648

**Ethernet MAC PMT control and status register (ETH\_MACPMTCSR)**

Address offset: 0x002C

Reset value: 0x0000 0000

The ETH\_MACPMTCSR programs the request wakeup events and monitors the wakeup events.

	31	30	29	28	27	26	25	24	23	22	21	20	19	18	17	16	15	14	13	12	11	10	9	8	7	6	5	4	3	2	1	0						
WFFRPR	Reserved																						GU	Reserved		WFR	MPR	Reserved		WFE	MPE	PD						
rs	Res.																						rw			rc_r	rc_r			rw	rw	rs						

Bit 31 **WFFRPR**: Wakeup frame filter register pointer reset

When set, it resets the Remote wakeup frame filter register pointer to 0b000. It is automatically cleared after 1 clock cycle.

Bits 30:10 Reserved

Bit 9 **GU**: Global unicast

When set, it enables any unicast packet filtered by the MAC (DAF) address recognition to be a wakeup frame.

Bits 8:7 Reserved

Bit 6 **WFR**: Wakeup frame received

When set, this bit indicates the power management event was generated due to reception of a wakeup frame. This bit is cleared by a read into this register.

Bit 5 **MPR**: Magic packet received

When set, this bit indicates the power management event was generated by the reception of a Magic Packet. This bit is cleared by a read into this register.

Bits 4:3 Reserved

Bit 2 **WFE**: Wakeup frame enable

When set, this bit enables the generation of a power management event due to wakeup frame reception.

Bit 1 **MPE**: Magic Packet enable

When set, this bit enables the generation of a power management event due to Magic Packet reception.

Bit 0 **PD**: Power down

When this bit is set, all received frames will be dropped. This bit is cleared automatically when a magic packet or wakeup frame is received, and Power-down mode is disabled. Frames received after this bit is cleared are forwarded to the application. This bit must only be set when either the Magic Packet Enable or Wakeup Frame Enable bit is set high.

**Ethernet MAC interrupt status register (ETH\_MACSR)**

Address offset: 0x0038

Reset value: 0x0000 0000

The ETH\_MACSR register contents identify the events in the MAC that can generate an interrupt.

15	14	13	12	11	10	9	8	7	6	5	4	3	2	1	0
Reserved						TSTS	Reserved		MMCTS	MMCRS	MMCS	PMTS	Reserved		
						rc_r			r	r	r	r			

Bits 15:10 Reserved

Bit 9 **TSTS**: Time stamp trigger status

This bit is set high when the system time value equals or exceeds the value specified in the Target time high and low registers. This bit is cleared when this register is read.

Bits 8:7 Reserved

Bit 6 **MMCTS**: MMC transmit status

This bit is set high whenever an interrupt is generated in the ETH\_MMCTIR Register. This bit is cleared when all the bits in this interrupt register (ETH\_MMCTIR) are cleared.

Bit 5 **MMCRS**: MMC receive status

This bit is set high whenever an interrupt is generated in the ETH\_MMCRIR register. This bit is cleared when all the bits in this interrupt register (ETH\_MMCRIR) are cleared.

Bit 4 **MMCS**: MMC status

This bit is set high whenever any of bits 6:5 is set high. It is cleared only when both bits are low.

Bit 3 **PMTS**: PMT status

This bit is set whenever a Magic packet or Wake-on-LAN frame is received in Power-down mode (See bits 5 and 6 in the ETH\_MACPMTCSR register *Ethernet MAC PMT control and status register (ETH\_MACPMTCSR) on page 991*). This bit is cleared when both bits[6:5], of this last register, are cleared due to a read operation to the ETH\_MACPMTCSR register.

Bits 2:0 Reserved



**Ethernet MAC interrupt mask register (ETH\_MACIMR)**

Address offset: 0x003C

Reset value: 0x0000 0000

The ETH\_MACIMR register bits make it possible to mask the interrupt signal due to the corresponding event in the ETH\_MACCSR register.

15	14	13	12	11	10	9	8	7	6	5	4	3	2	1	0	
Reserved						TSTIM	Reserved						PMTIM	Reserved		
						rw							rw			

Bits 15:10 Reserved

Bit 9 **TSTIM**: Time stamp trigger interrupt mask  
When set, this bit disables the time stamp interrupt generation.

Bits 8:4 Reserved

Bit 3 **PMTIM**: PMT interrupt mask  
When set, this bit disables the assertion of the interrupt signal due to the setting of the PMT Status bit in ETH\_MACCSR.

Bits 2:0 Reserved

**Ethernet MAC address 0 high register (ETH\_MACA0HR)**

Address offset: 0x0040

Reset value: 0x0010 FFFF

The MAC address 0 high register holds the upper 16 bits of the 6-byte first MAC address of the station. Note that the first DA byte that is received on the MII interface corresponds to the LS Byte (bits [7:0]) of the MAC address low register. For example, if 0x1122 3344 5566 is received (0x11 is the first byte) on the MII as the destination address, then the MAC address 0 register [47:0] is compared with 0x6655 4433 2211.

31	30	29	28	27	26	25	24	23	22	21	20	19	18	17	16	15	14	13	12	11	10	9	8	7	6	5	4	3	2	1	0														
MO	Reserved															MACA0H																													
1																rw	rw	rw	rw	rw	rw	rw	rw	rw	rw	rw	rw	rw	rw	rw	rw	rw	rw	rw	rw	rw	rw	rw	rw	rw	rw	rw	rw	rw	rw

Bit 31 **MO**: Always 1.

Bits 30:16 Reserved

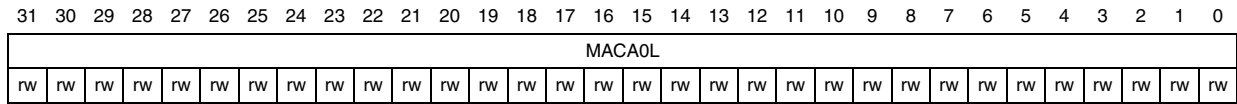
Bits 15:0 **MACA0H**: MAC address0 high [47:32]  
This field contains the upper 16 bits (47:32) of the 6-byte MAC address0. This is used by the MAC for filtering for received frames and for inserting the MAC address in the transmit flow control (Pause) frames.

**Ethernet MAC address 0 low register (ETH\_MACA0LR)**

Address offset: 0x0044

Reset value: 0xFFFF FFFF

The MAC address 0 low register holds the lower 32 bits of the 6-byte first MAC address of the station.



Bits 31:0 **MACA0L**: MAC address0 low [31:0]

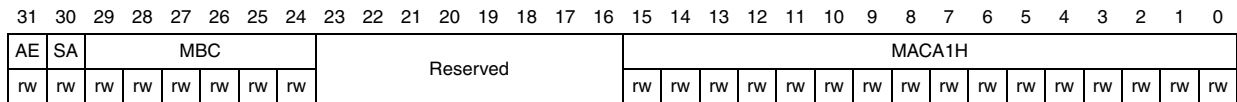
This field contains the lower 32 bits of the 6-byte MAC address0. This is used by the MAC for filtering for received frames and for inserting the MAC address in the transmit flow control (Pause) frames.

**Ethernet MAC address 1 high register (ETH\_MACA1HR)**

Address offset: 0x0048

Reset value: 0x0000 FFFF

The MAC address 1 high register holds the upper 16 bits of the 6-byte second MAC address of the station.



Bit 31 **AE**: Address enable

When this bit is set, the address filters use the MAC address1 for perfect filtering. When this bit is cleared, the address filters ignore the address for filtering.

Bit 30 **SA**: Source address

When this bit is set, the MAC address1[47:0] is used for comparison with the SA fields of the received frame.  
 When this bit is cleared, the MAC address1[47:0] is used for comparison with the DA fields of the received frame.

Bits 29:24 **MBC**: Mask byte control

These bits are mask control bits for comparison of each of the MAC address1 bytes. When they are set high, the MAC core does not compare the corresponding byte of received DA/SA with the contents of the MAC address1 registers. Each bit controls the masking of the bytes as follows:

- Bit 29: ETH\_MACA1HR [15:8]
- Bit 28: ETH\_MACA1HR [7:0]
- Bit 27: ETH\_MACA1LR [31:24]
- ...
- Bit 24: ETH\_MACA1LR [7:0]

Bits 23:16 Reserved



Bits 15:0 **MACA1H**: MAC address1 high [47:32]

This field contains the upper 16 bits (47:32) of the 6-byte second MAC address.

**Ethernet MAC address1 low register (ETH\_MACA1LR)**

Address offset: 0x004C

Reset value: 0xFFFF FFFF

The MAC address 1 low register holds the lower 32 bits of the 6-byte second MAC address of the station.

31	30	29	28	27	26	25	24	23	22	21	20	19	18	17	16	15	14	13	12	11	10	9	8	7	6	5	4	3	2	1	0	
MACA1L																																
rw	rw	rw	rw	rw	rw	rw	rw	rw	rw	rw	rw	rw	rw	rw	rw	rw	rw	rw	rw	rw	rw	rw	rw	rw	rw	rw	rw	rw	rw	rw	rw	rw

Bits 31:0 **MACA1L**: MAC address1 low [31:0]

This field contains the lower 32 bits of the 6-byte MAC address1. The content of this field is undefined until loaded by the application after the initialization process.

**Ethernet MAC address 2 high register (ETH\_MACA2HR)**

Address offset: 0x0050

Reset value: 0x0000 FFFF

The MAC address 2 high register holds the upper 16 bits of the 6-byte second MAC address of the station.

31	30	29	28	27	26	25	24	23	22	21	20	19	18	17	16	15	14	13	12	11	10	9	8	7	6	5	4	3	2	1	0		
AE	SA	MBC						Reserved									MACA2H																
rw	rw	rw	rw	rw	rw	rw	rw										rw	rw	rw	rw	rw	rw	rw	rw	rw	rw	rw	rw	rw	rw	rw	rw	rw

**AE**: Address enable

Bit 31 When this bit is set, the address filters use the MAC address2 for perfect filtering. When reset, the address filters ignore the address for filtering.

**SA**: Source address

When this bit is set, the MAC address 2 [47:0] is used for comparison with the SA fields of the Bit 30 received frame.

When this bit is reset, the MAC address 2 [47:0] is used for comparison with the DA fields of the received frame.

**MBC**: Mask byte control

These bits are mask control bits for comparison of each of the MAC address2 bytes. When set high, the MAC core does not compare the corresponding byte of received DA/SA with the contents of the MAC address 2 registers. Each bit controls the masking of the bytes as follows:

Bits 29:24 – Bit 29: ETH\_MACA2HR [15:8]

– Bit 28: ETH\_MACA2HR [7:0]

– Bit 27: ETH\_MACA2LR [31:24]

...

– Bit 24: ETH\_MACA2LR [7:0]

Bits 23:16Reserved

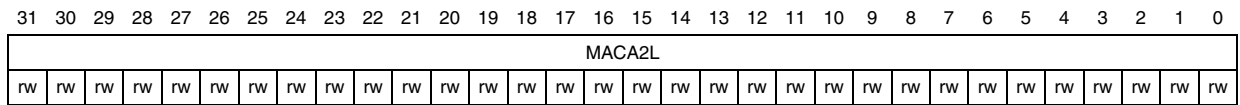
Bits 15:0 **MACA2H:** MAC address2 high [47:32]  
 This field contains the upper 16 bits (47:32) of the 6-byte MAC address2.

**Ethernet MAC address 2 low register (ETH\_MACA2LR)**

Address offset: 0x0054

Reset value: 0xFFFF FFFF

The MAC address 2 low register holds the lower 32 bits of the 6-byte second MAC address of the station.



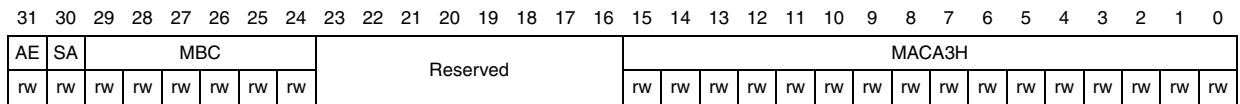
**MACA2L:** MAC address2 low [31:0]  
 Bits 31:0This field contains the lower 32 bits of the 6-byte second MAC address2. The content of this field is undefined until loaded by the application after the initialization process.

**Ethernet MAC address 3 high register (ETH\_MACA3HR)**

Address offset: 0x0058

Reset value: 0x0000 FFFF

The MAC address 3 high register holds the upper 16 bits of the 6-byte second MAC address of the station.



Bit 31 **AE:** Address enable  
 When this bit is set, the address filters use the MAC address3 for perfect filtering. When this bit is cleared, the address filters ignore the address for filtering.

Bit 30 **SA:** Source address  
 When this bit is set, the MAC address 3 [47:0] is used for comparison with the SA fields of the received frame.  
 When this bit is cleared, the MAC address 3[47:0] is used for comparison with the DA fields of the received frame.



Bits 29:24 **MBC**: Mask byte control

These bits are mask control bits for comparison of each of the MAC address3 bytes. When these bits are set high, the MAC core does not compare the corresponding byte of received DA/SA with the contents of the MAC address 3 registers. Each bit controls the masking of the bytes as follows:

- Bit 29: ETH\_MACA3HR [15:8]
- Bit 28: ETH\_MACA3HR [7:0]
- Bit 27: ETH\_MACA3LR [31:24]
- ...
- Bit 24: ETH\_MACA3LR [7:0]

Bits 23:16 Reserved

Bits 15:0 **MACA3H**: MAC address3 high [47:32]

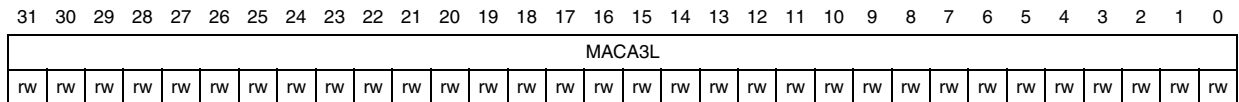
This field contains the upper 16 bits (47:32) of the 6-byte MAC address3.

### Ethernet MAC address 3 low register (ETH\_MACA3LR)

Address offset: 0x005C

Reset value: 0xFFFF FFFF

The MAC address 3 low register holds the lower 32 bits of the 6-byte second MAC address of the station.



Bits 31:0 **MACA3L**: MAC address3 low [31:0]

This field contains the lower 32 bits of the 6-byte second MAC address3. The content of this field is undefined until loaded by the application after the initialization process.

### 28.8.2 MMC register description

#### Ethernet MMC control register (ETH\_MMCCR)

Address offset: 0x0100

Reset value: 0x0000 0000

The Ethernet MMC Control register establishes the operating mode of the management counters.

31	30	29	28	27	26	25	24	23	22	21	20	19	18	17	16	15	14	13	12	11	10	9	8	7	6	5	4	3	2	1	0
Reserved																												MCF	ROR	CSR	CR
																												rw	rw	rw	rw

Bits 31:4 Reserved

Bit 3 **MCF**: MMC counter freeze

When set, this bit freezes all the MMC counters to their current value. (None of the MMC counters are updated due to any transmitted or received frame until this bit is cleared to 0. If any MMC counter is read with the Reset on Read bit set, then that counter is also cleared in this mode.)

Bit 2 **ROR**: Reset on read

When this bit is set, the MMC counters is reset to zero after read (self-clearing after reset). The counters are cleared when the least significant byte lane (bits [7:0]) is read.

Bit 1 **CSR**: Counter stop rollover

When this bit is set, the counter does not roll over to zero after it reaches the maximum value.

Bit 0 **CR**: Counter reset

When it is set, all counters are reset. This bit is cleared automatically after 1 clock cycle.

#### Ethernet MMC receive interrupt register (ETH\_MMCRIR)

Address offset: 0x0104

Reset value: 0x0000 0000

The Ethernet MMC receive interrupt register maintains the interrupts generated when receive statistic counters reach half their maximum values. (MSB of the counter is set.) It is a 32-bit wide register. An interrupt bit is cleared when the respective MMC counter that caused the interrupt is read. The least significant byte lane (bits [7:0]) of the respective counter must be read in order to clear the interrupt bit.

31	30	29	28	27	26	25	24	23	22	21	20	19	18	17	16	15	14	13	12	11	10	9	8	7	6	5	4	3	2	1	0
Reserved														RGUFS	Reserved										RFAES	RFCES	Reserved				
														rc_r											rc_r	rc_r					

Bits 31:18 Reserved

Bit 17 **RGUFS**: Received Good Unicast Frames Status

This bit is set when the received, good unicast frames, counter reaches half the maximum value.

Bits 16:7 Reserved

Bit 6 **RFAES**: Received frames alignment error status

This bit is set when the received frames, with alignment error, counter reaches half the maximum value.

Bit 5 **RFCEs**: Received frames CRC error status

This bit is set when the received frames, with CRC error, counter reaches half the maximum value.

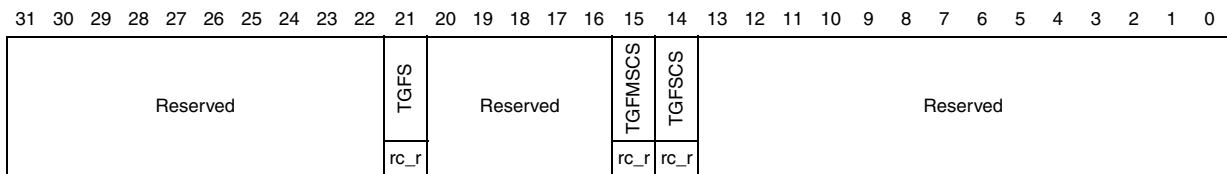
Bits 4:0 Reserved

**Ethernet MMC transmit interrupt register (ETH\_MMCTIR)**

Address offset: 0x0108

Reset value: 0x0000 0000

The Ethernet MMC transmit Interrupt register maintains the interrupts generated when transmit statistic counters reach half their maximum values. (MSB of the counter is set.) It is a 32-bit wide register. An interrupt bit is cleared when the respective MMC counter that caused the interrupt is read. The least significant byte lane (bits [7:0]) of the respective counter must be read in order to clear the interrupt bit.



Bits 31:22 Reserved

Bit 21 **TGFS**: Transmitted good frames status

This bit is set when the transmitted, good frames, counter reaches half the maximum value.

Bits 20:16 Reserved

Bit 15 **TGMSCS**: Transmitted good frames more single collision status

This bit is set when the transmitted, good frames after more than a single collision, counter reaches half the maximum value.

Bit 14 **TGFSCS**: Transmitted good frames single collision status

This bit is set when the transmitted, good frames after a single collision, counter reaches half the maximum value.

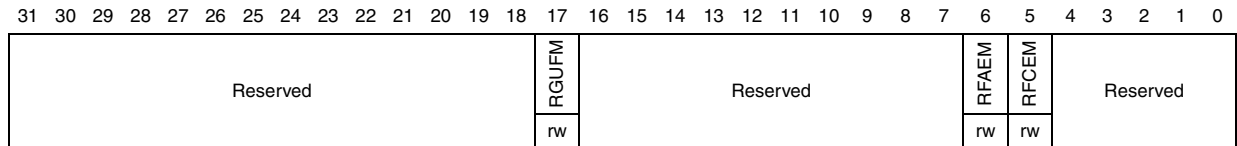
Bits 13:0 Reserved

**Ethernet MMC receive interrupt mask register (ETH\_MMCRIMR)**

Address offset: 0x010C

Reset value: 0x0000 0000

The Ethernet MMC receive interrupt mask register maintains the masks for interrupts generated when the receive statistic counters reach half their maximum value. (MSB of the counter is set.) It is a 32-bit wide register.



Bits 31:18 Reserved

Bit 17 **RGUFM**: Received good unicast frames mask

Setting this bit masks the interrupt when the received, good unicast frames, counter reaches half the maximum value.

Bits 16:7 Reserved

Bit 6 **RFAEM**: Received frames alignment error mask

Setting this bit masks the interrupt when the received frames, with alignment error, counter reaches half the maximum value.

Bit 5 **RFCEM**: Received frame CRC error mask

Setting this bit masks the interrupt when the received frames, with CRC error, counter reaches half the maximum value.

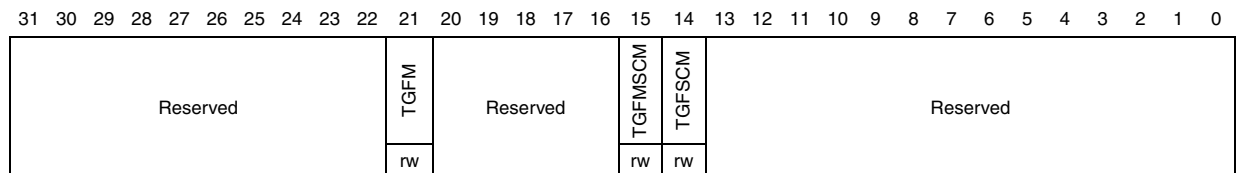
Bits 4:0 Reserved

**Ethernet MMC transmit interrupt mask register (ETH\_MMCTIMR)**

Address offset: 0x0110

Reset value: 0x0000 0000

The Ethernet MMC transmit interrupt mask register maintains the masks for interrupts generated when the transmit statistic counters reach half their maximum value. (MSB of the counter is set). It is a 32-bit wide register.



Bits 31:22 Reserved

Bit 21 **TGFM**: Transmitted good frames mask

Setting this bit masks the interrupt when the transmitted, good frames, counter reaches half the maximum value.

Bits 20:16 Reserved



Bit 15 **TGMSCM**: Transmitted good frames more single collision mask  
 Setting this bit masks the interrupt when the transmitted good frames after more than a single collision counter reaches half the maximum value.

Bit 14 **TGFSCM**: Transmitted good frames single collision mask  
 Setting this bit masks the interrupt when the transmitted good frames after a single collision counter reaches half the maximum value.

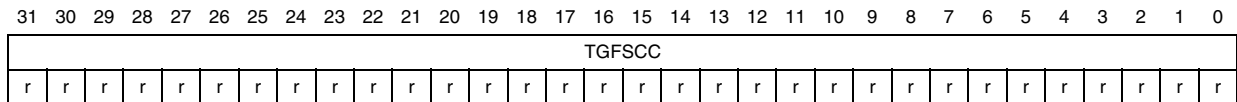
Bits 13:0 Reserved

**Ethernet MMC transmitted good frames after a single collision counter register (ETH\_MMCTGFSCCR)**

Address offset: 0x014C

Reset value: 0x0000 0000

This register contains the number of successfully transmitted frames after a single collision in Half-duplex mode.



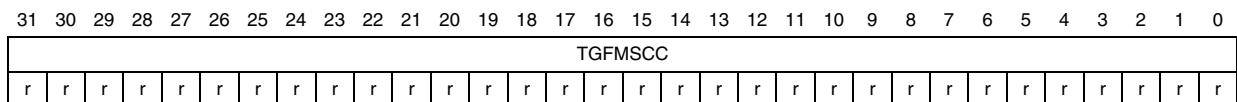
Bits 31:0 **TGFSCC**: Transmitted good frames single collision counter  
 Transmitted good frames after a single collision counter.

**Ethernet MMC transmitted good frames after more than a single collision counter register (ETH\_MMCTGFMSCCR)**

Address offset: 0x0150

Reset value: 0x0000 0000

This register contains the number of successfully transmitted frames after more than a single collision in Half-duplex mode.



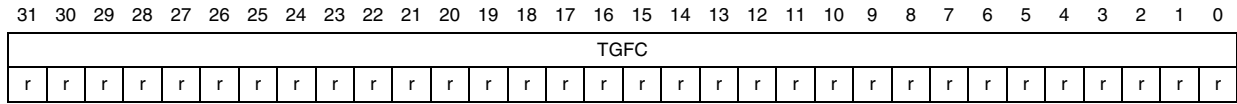
Bits 31:0 **TGFMSCC**: Transmitted good frames more single collision counter  
 Transmitted good frames after more than a single collision counter

**Ethernet MMC transmitted good frames counter register (ETH\_MMCTGFCR)**

Address offset: 0x0168

Reset value: 0x0000 0000

This register contains the number of good frames transmitted.



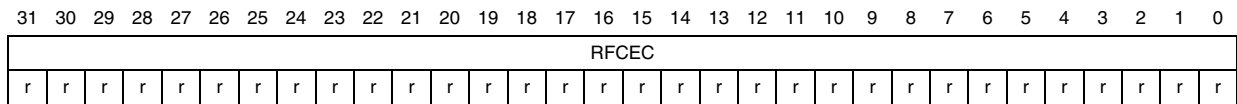
Bits 31:0 **TGFC**: Transmitted good frames counter

**Ethernet MMC received frames with CRC error counter register (ETH\_MMCRFCECR)**

Address offset: 0x0194

Reset value: 0x0000 0000

This register contains the number of frames received with CRC error.



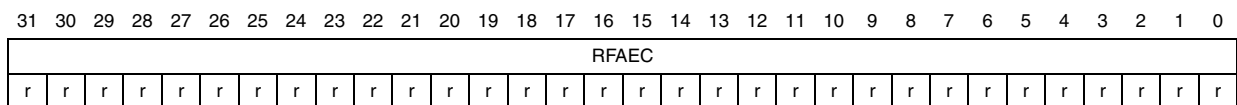
Bits 31:0 **RFCEC**: Received frames CRC error counter  
Received frames with CRC error counter

**Ethernet MMC received frames with alignment error counter register (ETH\_MMCRFAECR)**

Address offset: 0x0198

Reset value: 0x0000 0000

This register contains the number of frames received with alignment (dribble) error.



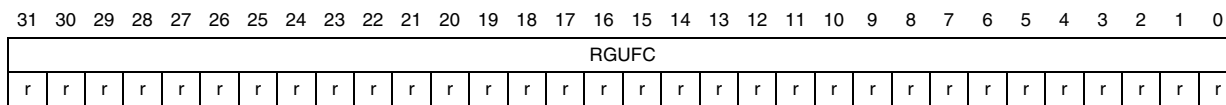
Bits 31:0 **RFAEC**: Received frames alignment error counter  
Received frames with alignment error counter

**MMC received good unicast frames counter register (ETH\_MMCRGUFCR)**

Address offset: 0x01C4

Reset value: 0x0000 0000

This register contains the number of good unicast frames received.



Bits 31:0 **RGUFC**: Received good unicast frames counter

**28.8.3 IEEE 1588 time stamp registers**

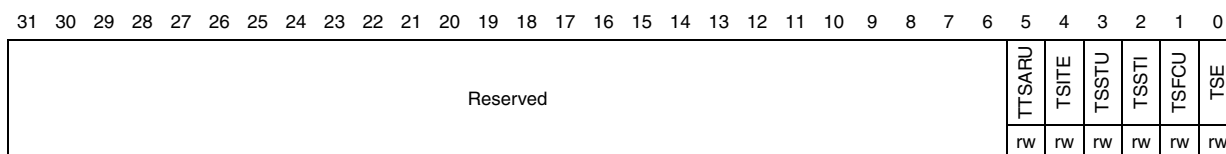
This section describes the registers required to support precision network clock synchronization functions under the IEEE 1588 standard.

**Ethernet PTP time stamp control register (ETH\_PTPTSCR)**

Address offset: 0x0700

Reset value: 0x0000 0000

This register controls the time stamp generation and update logic.



Bits 31:5 Reserved

Bit 5 **TSARU**: Time stamp addend register update

When this bit is set, the Time stamp addend register's contents are updated to the PTP block for fine correction. This bit is cleared when the update is completed. This register bit must be read as zero before you can set it.

Bit 4 **TSITE**: Time stamp interrupt trigger enable

When this bit is set, a time stamp interrupt is generated when the system time becomes greater than the value written in Target Time register. When the Time Stamp Trigger interrupt is generated, this bit is cleared.

Bit 3 **TSSTU**: Time stamp system time update

When this bit is set, the system time is updated (added to or subtracted from) with the value specified in the Time stamp high update and Time stamp low update registers. Both the TSSTU and TSSTI bits must be read as zero before you can set this bit. Once the update is completed in hardware, this bit is cleared.

Bit 2 **TSSTI**: Time stamp system time initialize

When this bit is set, the system time is initialized (overwritten) with the value specified in the Time stamp high update and Time stamp low update registers. This bit must be read as zero before you can set it. When initialization is complete, this bit is cleared.

Bit 1 **TSFCU**: Time stamp fine or coarse update

When set, this bit indicates that the system time stamp is to be updated using the Fine Update method. When cleared, it indicates the system time stamp is to be updated using the Coarse method.

Bit 0 **TSE**: Time stamp enable

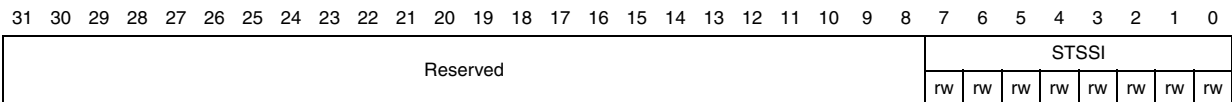
When this bit is set, time stamping is enabled for transmit and receive frames. When this bit is cleared, the time stamp function is suspended and time stamps are not added for transmit and receive frames. Because the maintained system time is suspended, you must always initialize the time stamp feature (system time) after setting this bit high.

**Ethernet PTP subsecond increment register (ETH\_PTPSSIR)**

Address offset: 0x0704

Reset value: 0x0000 0000

This register contains the 8-bit value by which the subsecond register is incremented. In Coarse update mode (TSFCU bit in ETH\_PTPTSCR), the value in this register is added to the system time every clock cycle of HCLK. In Fine update mode, the value in this register is added to the system time whenever the accumulator gets an overflow.



Bits 31:8 Reserved

Bits 7:0 **STSSI**: System time subsecond increment

The value programmed in this register is added to the contents of the subsecond value of the system time in every update.

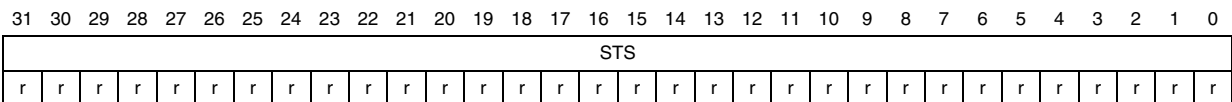
For example, to achieve 20 ns accuracy, the value is:  $20 / 0.467 = \sim 43$  (or 0x2A).

**Ethernet PTP time stamp high register (ETH\_PTPTSHR)**

Address offset: 0x0708

Reset value: 0x0000 0000

This register contains the most significant (higher) 32 time bits. This read-only register contains the seconds system time value. The Time stamp high register, along with Time stamp low register, indicates the current value of the system time maintained by the MAC. Though it is updated on a continuous basis.



Bits 31:0 **STS**: System time second

The value in this field indicates the current value in seconds of the System Time maintained by the core.

**Ethernet PTP time stamp low register (ETH\_PTPTSLR)**

Address offset: 0x070C

Reset value: 0x0000 0000

This register contains the least significant (lower) 32 time bits. This read-only register contains the subsecond system time value.

	31	30	29	28	27	26	25	24	23	22	21	20	19	18	17	16	15	14	13	12	11	10	9	8	7	6	5	4	3	2	1	0	
STPNS	STSS																																
	r	r	r	r	r	r	r	r	r	r	r	r	r	r	r	r	r	r	r	r	r	r	r	r	r	r	r	r	r	r	r	r	r

Bit 31 **STPNS**: System time positive or negative sign  
 This bit indicates a positive or negative time value. When set, the bit indicates that time representation is negative. When cleared, it indicates that time representation is positive. Because the system time should always be positive, this bit is normally zero.

Bits 30:0 **STSS**: System time subseconds  
 The value in this field has the subsecond time representation, with 0.46 ns accuracy.

**Ethernet PTP time stamp high update register (ETH\_PTPTSHUR)**

Address offset: 0x0710

Reset value: 0x0000 0000

This register contains the most significant (higher) 32 bits of the time to be written to, added to, or subtracted from the System Time value. The Time stamp high update register, along with the Time stamp update low register, initializes or updates the system time maintained by the MAC. You have to write both of these registers before setting the TSSTI or TSSTU bits in the Time stamp control register.

	31	30	29	28	27	26	25	24	23	22	21	20	19	18	17	16	15	14	13	12	11	10	9	8	7	6	5	4	3	2	1	0	
	TSUS																																
	r	w	r	w	r	w	r	w	r	w	r	w	r	w	r	w	r	w	r	w	r	w	r	w	r	w	r	w	r	w	r	w	r

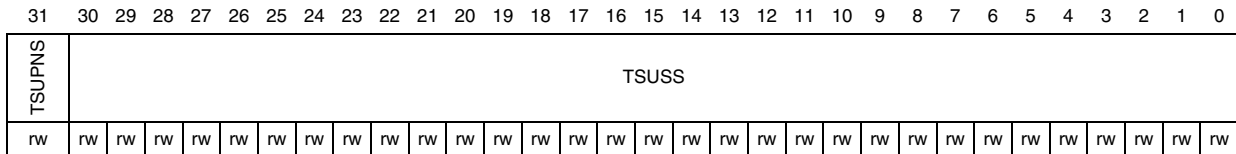
Bits 31:0 **TSUS**: Time stamp update second  
 The value in this field indicates the time, in seconds, to be initialized or added to the system time.

**Ethernet PTP time stamp low update register (ETH\_PTPTSLUR)**

Address offset: 0x0714

Reset value: 0x0000 0000

This register contains the least significant (lower) 32 bits of the time to be written to, added to, or subtracted from the System Time value.



**Bit 31 TSUPNS:** Time stamp update positive or negative sign  
 This bit indicates positive or negative time value. When set, the bit indicates that time representation is negative. When cleared, it indicates that time representation is positive. When TSSTI is set (system time initialization) this bit should be zero. If this bit is set when TSSTU is set, the value in the Time stamp update registers is subtracted from the system time. Otherwise it is added to the system time.

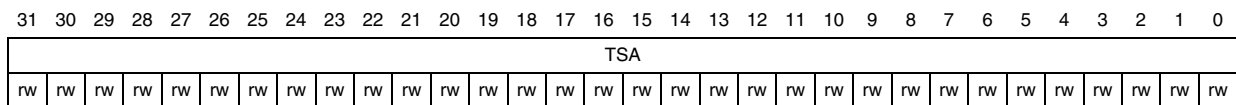
**Bits 30:0 TSUSS:** Time stamp update subseconds  
 The value in this field indicates the subsecond time to be initialized or added to the system time. This value has an accuracy of 0.46 ns (in other words, a value of 0x0000\_0001 is 0.46 ns).

**Ethernet PTP time stamp addend register (ETH\_PTPTSAR)**

Address offset: 0x0718

Reset value: 0x0000 0000

This register is used by the software to readjust the clock frequency linearly to match the master clock frequency. This register value is used only when the system time is configured for Fine update mode (TSFCU bit in ETH\_PTPTSCR). This register content is added to a 32-bit accumulator in every clock cycle and the system time is updated whenever the accumulator overflows.



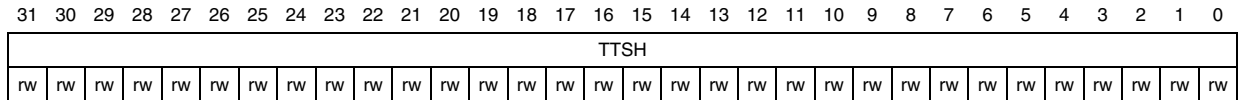
**Bits 31:0 TSA:** Time stamp addend  
 This register indicates the 32-bit time value to be added to the Accumulator register to achieve time synchronization.

**Ethernet PTP target time high register (ETH\_PTPTTHR)**

Address offset: 0x071C

Reset value: 0x0000 0000

This register contains the higher 32 bits of time to be compared with the system time for interrupt event generation. The Target time high register, along with Target time low register, is used to schedule an interrupt event (TSARU bit in ETH\_PTPTSCR) when the system time exceeds the value programmed in these registers.



Bits 31:0 **TTSH**: Target time stamp high

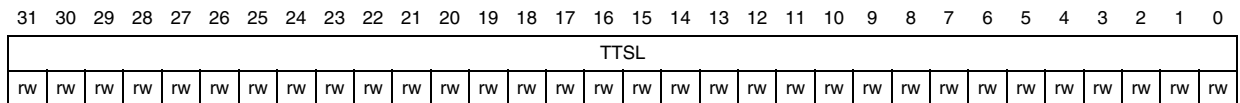
This register stores the time in seconds. When the time stamp value matches or exceeds both Target time stamp registers, the MAC, if enabled, generates an interrupt.

**Ethernet PTP target time low register (ETH\_PTPTTLR)**

Address offset: 0x0720

Reset value: 0x0000 0000

This register contains the lower 32 bits of time to be compared with the system time for interrupt event generation.



Bits 31:0 **TTSL**: Target time stamp low

This register stores the time in (signed) nanoseconds. When the value of the time stamp matches or exceeds both Target time stamp registers, the MAC, if enabled, generates an interrupt.

**28.8.4 DMA register description**

This section defines the bits for each DMA register. Non-32 bit accesses are allowed as long as the address is word-aligned.

**Ethernet DMA bus mode register (ETH\_DMABMR)**

Address offset: 0x1000

Reset value: 0x0000 2101

The bus mode register establishes the bus operating modes for the DMA.

31	30	29	28	27	26	25	24	23	22	21	20	19	18	17	16	15	14	13	12	11	10	9	8	7	6	5	4	3	2	1	0		
Reserved						AAB	FPM	USP	RDP						FB	RTPR	PBL						Reserved	DSL					DA	SL			
						rw	rw	rw	rw	rw	rw	rw	rw	rw	rw	rw	rw	rw	rw	rw	rw	rw	rw	rw	rw	rw	rw	rw	rw	rw	rw	rw	rs

Bits 31:26 Reserved

Bit 25 **AAB**: Address-aligned beats

When this bit is set high and the FB bit equals 1, the AHB interface generates all bursts aligned to the start address LS bits. If the FB bit equals 0, the first burst (accessing the data buffer's start address) is not aligned, but subsequent bursts are aligned to the address.

Bit 24 **FPM**: 4xPBL mode

When set high, this bit multiplies the PBL value programmed (bits [22:17] and bits [13:8]) four times. Thus the DMA transfers data in a maximum of 4, 8, 16, 32, 64 and 128 beats depending on the PBL value.

Bit 23 **USP**: Use separate PBL

When set high, it configures the RxDMA to use the value configured in bits [22:17] as PBL while the PBL value in bits [13:8] is applicable to TxDMA operations only. When this bit is cleared, the PBL value in bits [13:8] is applicable for both DMA engines.

Bits 22:17 **RDP**: Rx DMA PBL

These bits indicate the maximum number of beats to be transferred in one RxDMA transaction. This is the maximum value that is used in a single block read/write operation. The RxDMA always attempts to burst as specified in RDP each time it starts a burst transfer on the host bus. RDP can be programmed with permissible values of 1, 2, 4, 8, 16, and 32. Any other value results in undefined behavior.

These bits are valid and applicable only when USP is set high.

Bit 16 **FB**: Fixed burst

This bit controls whether the AHB Master interface performs fixed burst transfers or not. When set, the AHB uses only SINGLE, INCR4, INCR8 or INCR16 during start of normal burst transfers. When reset, the AHB uses SINGLE and INCR burst transfer operations.

Bits 15:14 **RTPR**: Rx Tx priority ratio

RxDMA requests are given priority over TxDMA requests in the following ratio:

- 00: 1:1
- 01: 2:1
- 10: 3:1
- 11: 4:1

This is valid only when the DA bit is cleared.



Bits 13:8 **PBL**: Programmable burst length

These bits indicate the maximum number of beats to be transferred in one DMA transaction. This is the maximum value that is used in a single block read/write operation. The DMA always attempts to burst as specified in PBL each time it starts a burst transfer on the host bus. PBL can be programmed with permissible values of 1, 2, 4, 8, 16, and 32. Any other value results in undefined behavior. When USP is set, this PBL value is applicable for TxDMA transactions only.

The PBL values have the following limitations:

- The maximum number of beats (PBL) possible is limited by the size of the Tx FIFO and Rx FIFO.
- The FIFO has a constraint that the maximum beat supported is half the depth of the FIFO.
- If the PBL is common for both transmit and receive DMA, the minimum Rx FIFO and Tx FIFO depths must be considered.
- Do not program out-of-range PBL values, because the system may not behave properly.

Bit 7 Reserved

Bits 6:2 **DSL**: Descriptor skip length

This bit specifies the number of words to skip between two unchained descriptors. The address skipping starts from the end of current descriptor to the start of next descriptor. When DSL value equals zero, the descriptor table is taken as contiguous by the DMA, in Ring mode.

Bit 1 **DA**: DMA Arbitration

- 0: Round-robin with Rx:Tx priority given in bits [15:14]
- 1: Rx has priority over Tx

Bit 0 **SR**: Software reset

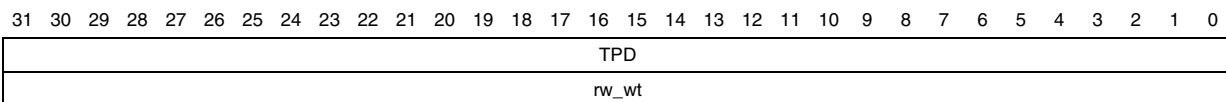
When this bit is set, the MAC DMA controller resets all MAC Subsystem internal registers and logic. It is cleared automatically after the reset operation has completed in all of the core clock domains. Read a 0 value in this bit before re-programming any register of the core.

**Ethernet DMA transmit poll demand register (ETH\_DMATPDR)**

Address offset: 0x1004

Reset value: 0x0000 0000

This register is used by the application to instruct the DMA to poll the transmit descriptor list. The transmit poll demand register enables the Transmit DMA to check whether or not the current descriptor is owned by DMA. The Transmit Poll Demand command is given to wake up the TxDMA if it is in Suspend mode. The TxDMA can go into Suspend mode due to an underflow error in a transmitted frame or due to the unavailability of descriptors owned by transmit DMA. You can issue this command anytime and the TxDMA resets it once it starts re-fetching the current descriptor from host memory.



Bits 31:0 TPD: Transmit poll demand

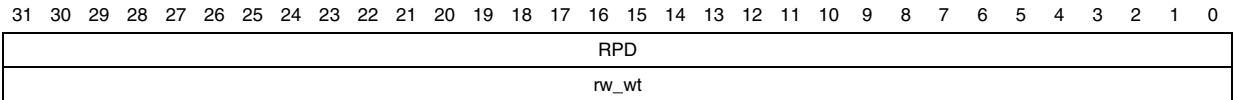
When these bits are written with any value, the DMA reads the current descriptor pointed to by the ETH\_DMACHTDR register. If that descriptor is not available (owned by Host), transmission returns to the Suspend state and ETH\_DMASR register bit 2 is asserted. If the descriptor is available, transmission resumes.

**ETHERNET DMA receive poll demand register (ETH\_DMARPDR)**

Address offset: 0x1008

Reset value: 0x0000 0000

This register is used by the application to instruct the DMA to poll the receive descriptor list. The Receive poll demand register enables the receive DMA to check for new descriptors. This command is given to wake up the RxDMA from Suspend state. The RxDMA can go into Suspend state only due to the unavailability of descriptors owned by it.



Bits 31:0 **RPD**: Receive poll demand

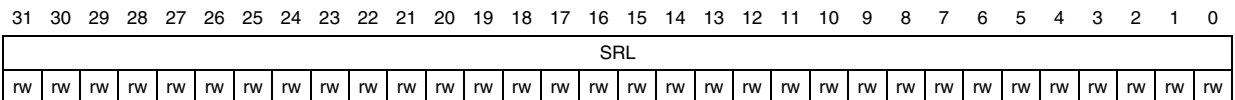
When these bits are written with any value, the DMA reads the current descriptor pointed to by the ETH\_DMACHRDR register. If that descriptor is not available (owned by Host), reception returns to the Suspended state and ETH\_DMASR register bit 7 is not asserted. If the descriptor is available, the Receive DMA returns to active state.

**Ethernet DMA receive descriptor list address register (ETH\_DMARDLAR)**

Address offset: 0x100C

Reset value: 0x0000 0000

The Receive descriptor list address register points to the start of the receive descriptor list. The descriptor lists reside in the STM32F107xx's physical memory space and must be word-aligned. The DMA internally converts it to bus-width aligned address by making the corresponding LS bits low. Writing to the ETH\_DMARDLAR register is permitted only when reception is stopped. When stopped, the ETH\_DMARDLAR register must be written to before the receive Start command is given.



Bits 31:0 **SRL**: Start of receive list

This field contains the base address of the first descriptor in the receive descriptor list. The LSB bits [1/2/3:0] for 32/64/128-bit bus width) are internally ignored and taken as all-zero by the DMA. Hence these LSB bits are read only.

**Ethernet DMA transmit descriptor list address register (ETH\_DMATDLAR)**

Address offset: 0x1010

Reset value: 0x0000 0000

The Transmit descriptor list address register points to the start of the transmit descriptor list. The descriptor lists reside in the STM32F107xx's physical memory space and must be word-aligned. The DMA internally converts it to bus-width-aligned address by taking the corresponding LSB to low. Writing to the ETH\_DMATDLAR register is permitted only when

transmission has stopped. Once transmission has stopped, the ETH\_DMATDLAR register can be written before the transmission Start command is given.

31	30	29	28	27	26	25	24	23	22	21	20	19	18	17	16	15	14	13	12	11	10	9	8	7	6	5	4	3	2	1	0	
STL																																
rw	rw	rw	rw	rw	rw	rw	rw	rw	rw	rw	rw	rw	rw	rw	rw	rw	rw	rw	rw	rw	rw	rw	rw	rw	rw	rw	rw	rw	rw	rw	rw	rw

Bits 31:0 **STL**: Start of transmit list

This field contains the base address of the first descriptor in the transmit descriptor list. The LSB bits [1/2/3:0] for 32/64/128-bit bus width) are internally ignored and taken as all-zero by the DMA. Hence these LSB bits are read-only.

### Ethernet DMA status register (ETH\_DMASR)

Address offset: 0x1014

Reset value: 0x0000 0000

The Status register contains all the status bits that the DMA reports to the application. The ETH\_DMASR register is usually read by the software driver during an interrupt service routine or polling. Most of the fields in this register cause the host to be interrupted. The ETH\_DMASR register bits are not cleared when read. Writing 1 to (unreserved) bits in ETH\_DMASR register[16:0] clears them and writing 0 has no effect. Each field (bits [16:0]) can be masked by masking the appropriate bit in the ETH\_DMAIER register.

31	30	29	28	27	26	25	24	23	22	21	20	19	18	17	16	15	14	13	12	11	10	9	8	7	6	5	4	3	2	1	0
Reserved	TSTS	PMTS	MMCS	Reserved	EBS			TPS			RPS		NIS	AIS	ERS	FBES	Reserved	ETS	RWTS	RPSS	RBUS	RS	TUS	ROS	TJTS	TBUS	TPSS	TS			
					r	r	r	r	r	r	r	r	r	rc-w1	rc-w1	rc-w1		rc-w1	rc-w1	rc-w1	rc-w1	rc-w1	rc-w1	rc-w1	rc-w1	rc-w1	rc-w1	rc-w1	rc-w1	rc-w1	rc-w1

Bits 31:30 Reserved

Bit 29 **TSTS**: Time stamp trigger status

This bit indicates an interrupt event in the MAC core's Time stamp generator block. The software must read the MAC core's status register, clearing its source (bit 9), to reset this bit to 0. When this bit is high an interrupt is generated if enabled.

Bit 28 **PMTS**: PMT status

This bit indicates an event in the MAC core's PMT. The software must read the corresponding registers in the MAC core to get the exact cause of interrupt and clear its source to reset this bit to 0. The interrupt is generated when this bit is high if enabled.

Bit 27 **MMCS**: MMC status

This bit reflects an event in the MMC of the MAC core. The software must read the corresponding registers in the MAC core to get the exact cause of interrupt and clear the source of interrupt to make this bit as 0. The interrupt is generated when this bit is high if enabled.

Bit 26 Reserved

Bits 25:23 **EBS**: Error bits status

These bits indicate the type of error that caused a bus error (error response on the AHB interface). Valid only with the fatal bus error bit (ETH\_DMASR register [13]) set. This field does not generate an interrupt.

Bit 23	1	Error during data transfer by TxDMA
	0	Error during data transfer by RxDMA
Bit 24	1	Error during read transfer
	0	Error during write transfer
Bit 25	1	Error during descriptor access
	0	Error during data buffer access

Bits 22:20 **TPS**: Transmit process state

These bits indicate the Transmit DMA FSM state. This field does not generate an interrupt.

000:	Stopped; Reset or Stop Transmit Command issued
001:	Running; Fetching transmit transfer descriptor
010:	Running; Waiting for status
011:	Running; Reading Data from host memory buffer and queuing it to transmit buffer (Tx FIFO)
100, 101:	Reserved for future use
110:	Suspended; Transmit descriptor unavailable or transmit buffer underflow
111:	Running; Closing transmit descriptor

Bits 19:17 **RPS**: Receive process state

These bits indicate the Receive DMA FSM state. This field does not generate an interrupt.

000:	Stopped: Reset or Stop Receive Command issued
001:	Running: Fetching receive transfer descriptor
010:	Reserved for future use
011:	Running: Waiting for receive packet
100:	Suspended: Receive descriptor unavailable
101:	Running: Closing receive descriptor
110:	Reserved for future use
111:	Running: Transferring the receive packet data from receive buffer to host memory

Bit 16 **NIS**: Normal interrupt summary

The normal interrupt summary bit value is the logical OR of the following when the corresponding interrupt bits are enabled in the ETH\_DMAIER register:

- ETH\_DMASR [0]: Transmit interrupt
- ETH\_DMASR [2]: Transmit buffer unavailable
- ETH\_DMASR [6]: Receive interrupt
- ETH\_DMASR [14]: Early receive interrupt

Only unmasked bits affect the normal interrupt summary bit.

This is a sticky bit and it must be cleared (by writing a 1 to this bit) each time a corresponding bit that causes NIS to be set is cleared.

**Bit 15 AIS:** Abnormal interrupt summary

The abnormal interrupt summary bit value is the logical OR of the following when the corresponding interrupt bits are enabled in the ETH\_DMAIER register:

- ETH\_DMASR [1]: Transmit process stopped
- ETH\_DMASR [3]: Transmit jabber timeout
- ETH\_DMASR [4]: Receive FIFO overflow
- ETH\_DMASR [5]: Transmit underflow
- ETH\_DMASR [7]: Receive buffer unavailable
- ETH\_DMASR [8]: Receive process stopped
- ETH\_DMASR [9]: Receive watchdog timeout
- ETH\_DMASR [10]: Early transmit interrupt
- ETH\_DMASR [13]: Fatal bus error

Only unmasked bits affect the abnormal interrupt summary bit.

This is a sticky bit and it must be cleared each time a corresponding bit that causes AIS to be set is cleared.

**Bit 14 ERS:** Early receive status

This bit indicates that the DMA had filled the first data buffer of the packet. Receive Interrupt ETH\_DMASR [6] automatically clears this bit.

**Bit 13 FBES:** Fatal bus error status

This bit indicates that a bus error occurred, as detailed in [25:23]. When this bit is set, the corresponding DMA engine disables all its bus accesses.

Bits 12:11 Reserved

**Bit 10 ETS:** Early transmit status

This bit indicates that the frame to be transmitted was fully transferred to the Transmit FIFO.

**Bit 9 RWTS:** Receive watchdog timeout status

This bit is asserted when a frame with a length greater than 2 048 bytes is received.

**Bit 8 RPSS:** Receive process stopped status

This bit is asserted when the receive process enters the Stopped state.

**Bit 7 RBUS:** Receive buffer unavailable status

This bit indicates that the next descriptor in the receive list is owned by the host and cannot be acquired by the DMA. Receive process is suspended. To resume processing receive descriptors, the host should change the ownership of the descriptor and issue a Receive Poll Demand command. If no Receive Poll Demand is issued, receive process resumes when the next recognized incoming frame is received. ETH\_DMASR [7] is set only when the previous receive descriptor was owned by the DMA.

**Bit 6 RS:** Receive status

This bit indicates the completion of the frame reception. Specific frame status information has been posted in the descriptor. Reception remains in the Running state.

**Bit 5 TUS:** Transmit underflow status

This bit indicates that the transmit buffer had an underflow during frame transmission. Transmission is suspended and an underflow error TDES0[1] is set.

**Bit 4 ROS:** Receive overflow status

This bit indicates that the receive buffer had an overflow during frame reception. If the partial frame is transferred to the application, the overflow status is set in RDES0[11].

- Bit 3 **TJTS**: Transmit jabber timeout status  
 This bit indicates that the transmit jabber timer expired, meaning that the transmitter had been excessively active. The transmission process is aborted and placed in the Stopped state. This causes the transmit jabber timeout TDES0[14] flag to be asserted.
- Bit 2 **TBUS**: Transmit buffer unavailable status  
 This bit indicates that the next descriptor in the transmit list is owned by the host and cannot be acquired by the DMA. Transmission is suspended. Bits [22:20] explain the transmit process state transitions. To resume processing transmit descriptors, the host should change the ownership of the bit of the descriptor and then issue a Transmit Poll Demand command.
- Bit 1 **TPSS**: Transmit process stopped status  
 This bit is set when the transmission is stopped.
- Bit 0 **TS**: Transmit status  
 This bit indicates that frame transmission is finished and TDES1[31] is set in the first descriptor.

**Ethernet DMA operation mode register (ETH\_DMAOMR)**

Address offset: 0x1018

Reset value: 0x0000 0000

The operation mode register establishes the Transmit and Receive operating modes and commands. The ETH\_DMAOMR register should be the last CSR to be written as part of DMA initialization.

31	30	29	28	27	26	25	24	23	22	21	20	19	18	17	16	15	14	13	12	11	10	9	8	7	6	5	4	3	2	1	0
Reserved				DTCEFD	RSF	DFRF	Reserved		TSF	FTF	Reserved			TTC		ST	Reserved				FEF	FUGF	Reserved	RTC		OSF	SR	Reserved			
				rw	rw	rw			rw	rs				rw	rw	rw	rw					rw	rw		rw	rw	rw	rw			

Bits 31:27 Reserved

- Bit 26 **DTCEFD**: Dropping of TCP/IP checksum error frames disable  
 When this bit is set, the core does not drop frames that only have errors detected by the receive checksum offload engine. Such frames do not have any errors (including FCS error) in the Ethernet frame received by the MAC but have errors in the encapsulated payload only. When this bit is cleared, all error frames are dropped if the FEF bit is reset.
- Bit 25 **RSF**: Receive store and forward  
 When this bit is set, a frame is read from the Rx FIFO after the complete frame has been written to it, ignoring RTC bits. When this bit is cleared, the Rx FIFO operates in Cut-through mode, subject to the threshold specified by the RTC bits.
- Bit 24 **DFRF**: Disable flushing of received frames  
 When this bit is set, the RxDMA does not flush any frames due to the unavailability of receive descriptors/buffers as it does normally when this bit is cleared. (See [Receive process suspended on page 972](#))

Bits 23:22 Reserved



**Bit 21 TSF:** Transmit store and forward

When this bit is set, transmission starts when a full frame resides in the Transmit FIFO. When this bit is set, the TTC values specified by the ETH\_DMAOMR register bits [16:14] are ignored. When this bit is cleared, the TTC values specified by the ETH\_DMAOMR register bits [16:14] are taken into account.

This bit should be changed only when transmission is stopped.

**Bit 20 FTF:** Flush transmit FIFO

When this bit is set, the transmit FIFO controller logic is reset to its default values and thus all data in the Tx FIFO are lost/flushed. This bit is cleared internally when the flushing operation is complete. The Operation mode register should not be written to until this bit is cleared.

Bits 19:17 Reserved

**Bits 16:14 TTC:** Transmit threshold control

These three bits control the threshold level of the Transmit FIFO. Transmission starts when the frame size within the Transmit FIFO is larger than the threshold. In addition, full frames with a length less than the threshold are also transmitted. These bits are used only when the TSF bit (Bit 21) is cleared.

000:	64
001:	128
010:	192
011:	256
100:	40
101:	32
110:	24
111:	16

**Bit 13 ST:** Start/stop transmission

When this bit is set, transmission is placed in the Running state, and the DMA checks the transmit list at the current position for a frame to be transmitted. Descriptor acquisition is attempted either from the current position in the list, which is the transmit list base address set by the ETH\_DMATDLAR register, or from the position retained when transmission was stopped previously. If the current descriptor is not owned by the DMA, transmission enters the Suspended state and the transmit buffer unavailable bit (ETH\_DMASR [2]) is set. The Start Transmission command is effective only when transmission is stopped. If the command is issued before setting the DMA ETH\_DMATDLAR register, the DMA behavior is unpredictable. When this bit is cleared, the transmission process is placed in the Stopped state after completing the transmission of the current frame. The next descriptor position in the transmit list is saved, and becomes the current position when transmission is restarted. The Stop Transmission command is effective only when the transmission of the current frame is complete or when the transmission is in the Suspended state.

Bits 12:8 Reserved

**Bit 7 FEF:** Forward error frames

When this bit is set, all frames except runt error frames are forwarded to the DMA.

When this bit is cleared, the Rx FIFO drops frames with error status (CRC error, collision error, giant frame, watchdog timeout, overflow). However, if the frame's start byte (write) pointer is already transferred to the read controller side (in Threshold mode), then the frames are not dropped. The Rx FIFO drops the error frames if that frame's start byte is not transferred (output) on the ARI bus.

**Bit 6 FUGF:** Forward undersized good frames

When this bit is set, the Rx FIFO forwards undersized frames (frames with no error and length less than 64 bytes) including pad-bytes and CRC).

When this bit is cleared, the Rx FIFO drops all frames of less than 64 bytes, unless such a frame has already been transferred due to lower value of receive threshold (e.g., RTC = 01).

**Bit 5** Reserved**Bits 4:3 RTC:** Receive threshold control

These two bits control the threshold level of the Receive FIFO. Transfer (request) to DMA starts when the frame size within the Receive FIFO is larger than the threshold. In addition, full frames with a length less than the threshold are transferred automatically.

*Note: Note that value of 11 is not applicable if the configured Receive FIFO size is 128 bytes.*

*Note: These bits are valid only when the RSF bit is zero, and are ignored when the RSF bit is set to 1.*

00: 64

01: 32

10: 96

11: 128

**Bit 2 OSF:** Operate on second frame

When this bit is set, this bit instructs the DMA to process a second frame of Transmit data even before status for first frame is obtained.

**Bit 1 SR:** Start/stop receive

When this bit is set, the receive process is placed in the Running state. The DMA attempts to acquire the descriptor from the receive list and processes incoming frames. Descriptor acquisition is attempted from the current position in the list, which is the address set by the DMA ETH\_DMARDLAR register or the position retained when the receive process was previously stopped. If no descriptor is owned by the DMA, reception is suspended and the receive buffer unavailable bit (ETH\_DMASR [7]) is set. The Start Receive command is effective only when reception has stopped. If the command was issued before setting the DMA ETH\_DMARDLAR register, the DMA behavior is unpredictable.

When this bit is cleared, RxDMA operation is stopped after the transfer of the current frame. The next descriptor position in the receive list is saved and becomes the current position when the receive process is restarted. The Stop Receive command is effective only when the Receive process is in either the Running (waiting for receive packet) or the Suspended state.

**Bit 0** Reserved



**Ethernet DMA interrupt enable register (ETH\_DMAIER)**

Address offset: 0x101C

Reset value: 0x0000 0000

The Interrupt enable register enables the interrupts reported by ETH\_DMASR. Setting a bit to 1 enables a corresponding interrupt. After a hardware or software reset, all interrupts are disabled.

31	30	29	28	27	26	25	24	23	22	21	20	19	18	17	16	15	14	13	12	11	10	9	8	7	6	5	4	3	2	1	0
Reserved															NISE	AISE	ERIE	FBEIE	Reserved	ETIE	RWTIE	RPSIE	RBUIE	RIE	TUIE	ROIE	TJTIE	TBUIE	TPSIE	TIE	
															rw	rw	rw	rw		rw	rw	rw	rw	rw	rw	rw	rw	rw	rw	rw	

Bits 31:17 Reserved

Bit 16 **NISE**: Normal interrupt summary enable

When this bit is set, a normal interrupt is enabled. When this bit is cleared, a normal interrupt is disabled. This bit enables the following bits:

- ETH\_DMASR [0]: Transmit Interrupt
- ETH\_DMASR [2]: Transmit buffer unavailable
- ETH\_DMASR [6]: Receive interrupt
- ETH\_DMASR [14]: Early receive interrupt

Bit 15 **AISE**: Abnormal interrupt summary enable

When this bit is set, an abnormal interrupt is enabled. When this bit is cleared, an abnormal interrupt is disabled. This bit enables the following bits:

- ETH\_DMASR [1]: Transmit process stopped
- ETH\_DMASR [3]: Transmit jabber timeout
- ETH\_DMASR [4]: Receive overflow
- ETH\_DMASR [5]: Transmit underflow
- ETH\_DMASR [7]: Receive buffer unavailable
- ETH\_DMASR [8]: Receive process stopped
- ETH\_DMASR [9]: Receive watchdog timeout
- ETH\_DMASR [10]: Early transmit interrupt
- ETH\_DMASR [13]: Fatal bus error

Bit 14 **ERIE**: Early receive interrupt enable

When this bit is set with the normal interrupt summary enable bit (ETH\_DMAIER register[16]), the early receive interrupt is enabled.

When this bit is cleared, the early receive interrupt is disabled.

Bit 13 **FBEIE**: Fatal bus error interrupt enable

When this bit is set with the abnormal interrupt summary enable bit (ETH\_DMAIER register[15]), the fatal bus error interrupt is enabled.

When this bit is cleared, the fatal bus error enable interrupt is disabled.

Bits 12:11 Reserved

Bit 10 **ETIE**: Early transmit interrupt enable

When this bit is set with the abnormal interrupt summary enable bit (ETH\_DMAIER register [15]), the early transmit interrupt is enabled.

When this bit is cleared, the early transmit interrupt is disabled.

- Bit 9 **RWTIE**: receive watchdog timeout interrupt enable  
When this bit is set with the abnormal interrupt summary enable bit (ETH\_DMAIER register[15]), the receive watchdog timeout interrupt is enabled.  
When this bit is cleared, the receive watchdog timeout interrupt is disabled.
- Bit 8 **RPSIE**: Receive process stopped interrupt enable  
When this bit is set with the abnormal interrupt summary enable bit (ETH\_DMAIER register[15]), the receive stopped interrupt is enabled. When this bit is cleared, the receive stopped interrupt is disabled.
- Bit 7 **RBUIE**: Receive buffer unavailable interrupt enable  
When this bit is set with the abnormal interrupt summary enable bit (ETH\_DMAIER register[15]), the receive buffer unavailable interrupt is enabled.  
When this bit is cleared, the receive buffer unavailable interrupt is disabled.
- Bit 6 **RIE**: Receive interrupt enable  
When this bit is set with the normal interrupt summary enable bit (ETH\_DMAIER register[16]), the receive interrupt is enabled.  
When this bit is cleared, the receive interrupt is disabled.
- Bit 5 **TUIE**: Underflow interrupt enable  
When this bit is set with the abnormal interrupt summary enable bit (ETH\_DMAIER register[15]), the transmit underflow interrupt is enabled.  
When this bit is cleared, the underflow interrupt is disabled.
- Bit 4 **ROIE**: Overflow interrupt enable  
When this bit is set with the abnormal interrupt summary enable bit (ETH\_DMAIER register[15]), the receive overflow interrupt is enabled.  
When this bit is cleared, the overflow interrupt is disabled.
- Bit 3 **TJTIE**: Transmit jabber timeout interrupt enable  
When this bit is set with the abnormal interrupt summary enable bit (ETH\_DMAIER register[15]), the transmit jabber timeout interrupt is enabled.  
When this bit is cleared, the transmit jabber timeout interrupt is disabled.
- Bit 2 **TBUIE**: Transmit buffer unavailable interrupt enable  
When this bit is set with the normal interrupt summary enable bit (ETH\_DMAIER register[16]), the transmit buffer unavailable interrupt is enabled.  
When this bit is cleared, the transmit buffer unavailable interrupt is disabled.
- Bit 1 **TPSIE**: Transmit process stopped interrupt enable  
When this bit is set with the abnormal interrupt summary enable bit (ETH\_DMAIER register[15]), the transmission stopped interrupt is enabled.  
When this bit is cleared, the transmission stopped interrupt is disabled.
- Bit 0 **TIE**: Transmit interrupt enable  
When this bit is set with the normal interrupt summary enable bit (ETH\_DMAIER register[16]), the transmit interrupt is enabled.  
When this bit is cleared, the transmit interrupt is disabled.

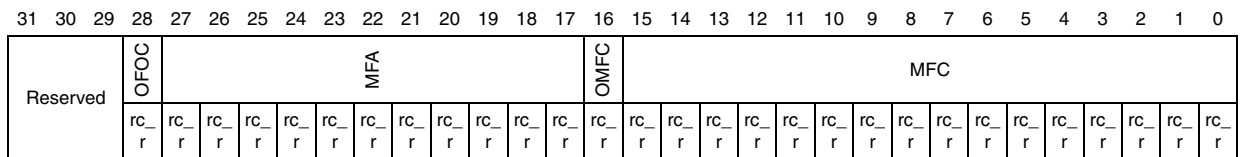
The Ethernet interrupt is generated only when the TSTS or PMTS bits of the DMA Status register is asserted with their corresponding interrupt are unmasked, or when the NIS/AIS Status bit is asserted and the corresponding Interrupt Enable bits (NISE/AISE) are enabled.

**Ethernet DMA missed frame and buffer overflow counter register (ETH\_DMAMFBOCR)**

Address offset: 0x1020

Reset value: 0x0000 0000

The DMA maintains two counters to track the number of missed frames during reception. This register reports the current value of the counter. The counter is used for diagnostic purposes. Bits [15:0] indicate missed frames due to the STM32F107xx buffer being unavailable (no receive descriptor was available). Bits [27:17] indicate missed frames due to Rx FIFO overflow conditions and runt frames (good frames of less than 64 bytes).



Bits 31:29 Reserved

Bit 28 **OFOC**: Overflow bit for FIFO overflow counter

Bits 27:17 **MFA**: Missed frames by the application  
 Indicates the number of frames missed by the application

Bit 16 **OMFC**: Overflow bit for missed frame counter

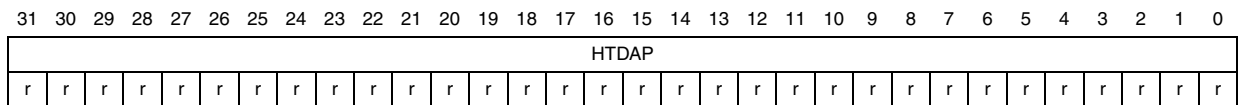
Bits 15:0 **MFC**: Missed frames by the controller  
 Indicates the number of frames missed by the Controller due to the host receive buffer being unavailable. This counter is incremented each time the DMA discards an incoming frame.

**Ethernet DMA current host transmit descriptor register (ETH\_DMACHTDR)**

Address offset: 0x1048

Reset value: 0x0000 0000

The Current host transmit descriptor register points to the start address of the current transmit descriptor read by the DMA.



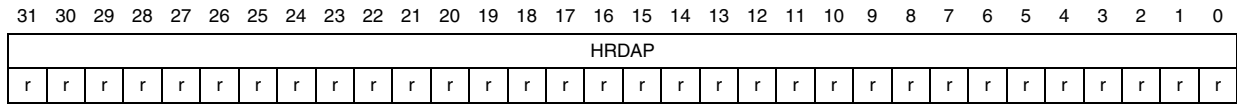
Bits 31:0 **HTDAP**: Host transmit descriptor address pointer  
 Cleared on reset. Pointer updated by DMA during operation.

**Ethernet DMA current host receive descriptor register (ETH\_DMACHRDR)**

Address offset: 0x104C

Reset value: 0x0000 0000

The Current host receive descriptor register points to the start address of the current receive descriptor read by the DMA.



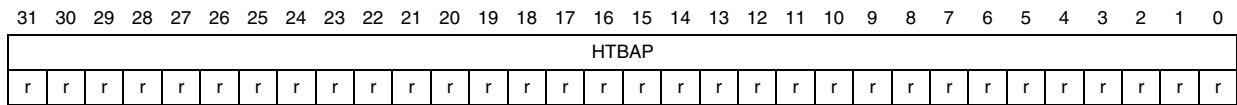
Bits 31:0 **HRDAP**: Host receive descriptor address pointer  
 Cleared on Reset. Pointer updated by DMA during operation.

**Ethernet DMA current host transmit buffer address register (ETH\_DMACHTBAR)**

Address offset: 0x1050

Reset value: 0x0000 0000

The Current host transmit buffer address register points to the current transmit buffer address being read by the DMA.



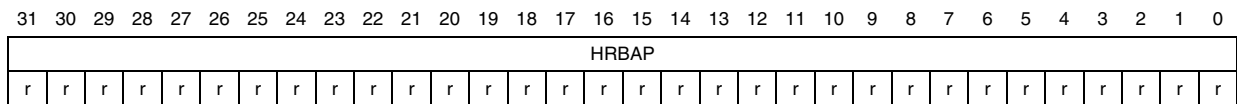
Bits 31:0 **HTBAP**: Host transmit buffer address pointer  
 Cleared on reset. Pointer updated by DMA during operation.

**Ethernet DMA current host receive buffer address register (ETH\_DMACHRBAR)**

Address offset: 0x1054

Reset value: 0x0000 0000

The current host receive buffer address register points to the current receive buffer address being read by the DMA.



Bits 31:0 **HRBAP**: Host receive buffer address pointer  
 Cleared on reset. Pointer updated by DMA during operation.

### 28.8.5 Ethernet register maps

Table 212 gives the ETH register map and reset values.

**Table 212. Ethernet register map and reset values**

Offset	Register	31	30	29	28	27	26	25	24	23	22	21	20	19	18	17	16	15	14	13	12	11	10	9	8	7	6	5	4	3	2	1	0													
0x00	ETH_MACCR	Reserved										WD	JD	Reserved			IFG			CSD	Reserved			FES	ROD	LM	DM	IPCO	RD	Reserved			APCS	BL	DC	TE	RE	Reserved								
	Reset value											0	0	Reserved			0	0	0	0	0	Reserved			0	0	0	0	0	0	0	0	0	0	0	0	0	0	Reserved							
0x04	ETH_MACFFR	RA	Reserved																				HPF	SAF	Reserved			PCF	BFD	PAM	DAIF	HM	HU	PM												
	Reset value	0																					0	0	Reserved			0	0	0	0	0	0	0	0	0	0	0	0	0	0	0	0	0	0	Reserved
0x08	ETH_MACHTHR	HTH[31:0]																																												
	Reset value	0 0																																												
0x0C	ETH_MACHTLR	HTL[31:0]																																												
	Reset value	0 0																																												
0x10	ETH_MACMIIAR	Reserved																PA				MR				Reserved		CR		M	M															
	Reset value																	0	0	0	0	0	0	0	0	0	0	0	0	0	0	0	0	0	0											
0x14	ETH_MACMII DR	Reserved																MD																												
	Reset value																	0 0																												
0x18	ETH_MACFCR	PT																Reserved								ZQPD	Reserved		PLT	UPFD	RFCE	TFCE	FCB/BPA													
	Reset value	0 0 0 0 0 0 0 0 0 0 0 0 0 0 0 0 0 0																								0	Reserved		0	0	0	0	0	0												
0x1C	ETH_MACVLANTR	Reserved																VLANTC	VLANTI																											
	Reset value																	0	0 0																											
0x28	ETH_MACRWUFFR	Frame filter reg0\Frame filter reg1\Frame filter reg2\Frame filter reg3\Frame filter reg4...\Frame filter reg7																																												
	Reset value	0																																												
0x2C	ETH_MACPM TCSR	WFFRPR	Reserved																				GU	Reserved		WFR	MPR	Reserved		WFE	MPE	PD														
	Reset value	0																					0	Reserved		0	0	Reserved		0	0	0														
0x38	ETH_MACSR	Not applicable																Reserved								TSTS	Reserved		MMCTS	MMCRS	MMCS	PMTS	Reserved													
	Reset value																									0	Reserved		0	0	0	0	Reserved													
0x3C	ETH_MACIMR	Not applicable																Reserved								TSTIM	Reserved				PMTIM	Reserved														
	Reset value																									0	Reserved				0	Reserved														
0x40	ETH_MACA0HR	MO	Reserved																MACA0H																											
	Reset value	1	0 0																1 1																											
0x44	ETH_MACA0LR	MACA0L																																												
	Reset value	1 1																																												
0x48	ETH_MACA1HR	AE	SA	MBC[6:0]				Reserved										MACA1H																												
	Reset value	0	0	0 0 0 0 0 0 0 0														1 1																												
0x4C	ETH_MACA1LR	MACA1L																																												
	Reset value	1 1																																												
0x50	ETH_MACA2HR	AE	SA	MBC				Reserved										MACA2H																												
	Reset value	0	0	0 0 0 0 0 0 0 0														1 1																												
0x54	ETH_MACA2LR	MACA2L																																												
	Reset value	1 1																																												



Table 212. Ethernet register map and reset values (continued)

Offset	Register	31	30	29	28	27	26	25	24	23	22	21	20	19	18	17	16	15	14	13	12	11	10	9	8	7	6	5	4	3	2	1	0			
0x58	ETH_MACA3HR	AE	SA	MBC						Reserved									MACA3H																	
	Reset value	0	0	0	0	0	0	0	0	0										1	1	1	1	1	1	1	1	1	1	1	1	1	1	1	1	1
0x5C	ETH_MACA3LR	MACA3L																																		
	Reset value	1	1	1	1	1	1	1	1	1	1	1	1	1	1	1	1	1	1	1	1	1	1	1	1	1	1	1	1	1	1	1	1	1		
0x100	ETH_MMCCR	Reserved																												MCF	FOR	CSR	CR			
	Reset value																													0	0	0	0			
0x104	ETH_MMCRIR	Reserved														RGUFS	Reserved										RFAES	RFCEES	Reserved							
	Reset value															0											0	0								
0x108	ETH_MMCTIR	Reserved										TGFS	Reserved						TGMSCS	TGFSCS	Reserved															
	Reset value											0							0	0																
0x10C	ETH_MMCRIMR	Reserved														RGUFM	Reserved										RFAEM	RFCEM	Reserved							
	Reset value															0											0	0								
0x110	ETH_MMCTIMR	Reserved										TGFM	Reserved						TGMSCM	TGFSCM	Reserved															
	Reset value											0							0	0																
0x14C	ETH_MMCTGFSCCR	TGFSCC																																		
	Reset value	0	0	0	0	0	0	0	0	0	0	0	0	0	0	0	0	0	0	0	0	0	0	0	0	0	0	0	0	0	0	0	0	0		
0x150	ETH_MMCTGFMSCCR	TGMSCC																																		
	Reset value	0	0	0	0	0	0	0	0	0	0	0	0	0	0	0	0	0	0	0	0	0	0	0	0	0	0	0	0	0	0	0	0	0		
0x168	ETH_MMCTGFCR	TGFC																																		
	Reset value	0	0	0	0	0	0	0	0	0	0	0	0	0	0	0	0	0	0	0	0	0	0	0	0	0	0	0	0	0	0	0	0	0		
0x194	ETH_MMCRFCECR	RFCEC																																		
	Reset value	0	0	0	0	0	0	0	0	0	0	0	0	0	0	0	0	0	0	0	0	0	0	0	0	0	0	0	0	0	0	0	0	0		
0x198	ETH_MMCRFAECR	RFAEC																																		
	Reset value	0	0	0	0	0	0	0	0	0	0	0	0	0	0	0	0	0	0	0	0	0	0	0	0	0	0	0	0	0	0	0	0	0		
0x1C4	ETH_MMCRGUFCR	RGUFC																																		
	Reset value	0	0	0	0	0	0	0	0	0	0	0	0	0	0	0	0	0	0	0	0	0	0	0	0	0	0	0	0	0	0	0	0	0		
0x700	ETH_PTPTSCR	Reserved																								TT SARU	TSITE	TSSTU	TSSTI	TSFCU	TSE					
	Reset value																									0	0	0	0	0	0					
0x704	ETH_PTPTSSIR	Reserved																								STSSI										
	Reset value																									0	0	0	0	0						
0x708	ETH_PTPTSHR	STS[31:0]																																		
	Reset value	0	0	0	0	0	0	0	0	0	0	0	0	0	0	0	0	0	0	0	0	0	0	0	0	0	0	0	0	0	0	0	0	0		
0x70C	ETH_PTPTSLR	STPNS	STSS																																	
	Reset value	0	0	0	0	0	0	0	0	0	0	0	0	0	0	0	0	0	0	0	0	0	0	0	0	0	0	0	0	0	0	0	0			
0x710	ETH_PTPTSHUR	TSUS																																		
	Reset value	0	0	0	0	0	0	0	0	0	0	0	0	0	0	0	0	0	0	0	0	0	0	0	0	0	0	0	0	0	0	0	0	0		
0x714	ETH_PTPTSLUR	TSUPNS	TSUSS																																	
	Reset value	0	0	0	0	0	0	0	0	0	0	0	0	0	0	0	0	0	0	0	0	0	0	0	0	0	0	0	0	0	0	0	0	0		



Table 212. Ethernet register map and reset values (continued)

Offset	Register	31	30	29	28	27	26	25	24	23	22	21	20	19	18	17	16	15	14	13	12	11	10	9	8	7	6	5	4	3	2	1	0
0x718	ETH_PTPTSAR	TSA																															
	Reset value	0	0	0	0	0	0	0	0	0	0	0	0	0	0	0	0	0	0	0	0	0	0	0	0	0	0	0	0	0	0	0	0
0x71C	ETH_PTPTHR	TTSH																															
	Reset value	0	0	0	0	0	0	0	0	0	0	0	0	0	0	0	0	0	0	0	0	0	0	0	0	0	0	0	0	0	0	0	0
0x720	ETH_PTPTHR	TTSL																															
	Reset value	0	0	0	0	0	0	0	0	0	0	0	0	0	0	0	0	0	0	0	0	0	0	0	0	0	0	0	0	0	0	0	0
0x1000	ETH_DMABMR	Reserved						AAB	FPM	USP	RDP				FB	RTPR	PBL				EDFE	DSL				DA	SF						
	Reset value	0	0	0	0	0	0	0	0	0	0	0	0	0	0	1	0	0	0	0	0	0	0	0	0	1	0	0	0	0	0	0	0
0x1004	ETH_DMATPDR	TPD																															
	Reset value	0	0	0	0	0	0	0	0	0	0	0	0	0	0	0	0	0	0	0	0	0	0	0	0	0	0	0	0	0	0	0	0
0x1008	ETH_DMARPDR	RPD																															
	Reset value	0	0	0	0	0	0	0	0	0	0	0	0	0	0	0	0	0	0	0	0	0	0	0	0	0	0	0	0	0	0	0	0
0x100C	ETH_DMARDLAR	SRL																															
	Reset value	0	0	0	0	0	0	0	0	0	0	0	0	0	0	0	0	0	0	0	0	0	0	0	0	0	0	0	0	0	0	0	0
0x1010	ETH_DMATDLAR	STL																															
	Reset value	0	0	0	0	0	0	0	0	0	0	0	0	0	0	0	0	0	0	0	0	0	0	0	0	0	0	0	0	0	0	0	0
0x1014	ETH_DMASR	Reserved	TSTS	PMTS	MMCS	Reserved	EBS	TPS				RPS	NIS	AIS	ERS	FBES	Reserved	ETS	RWTS	RPSS	RBUS	RS	TUS	ROS	TJTS	TBUS	TPSS	TS					
	Reset value	0	0	0	0	0	0	0	0	0	0	0	0	0	0	0	0	0	0	0	0	0	0	0	0	0	0	0	0	0	0	0	0
0x1018	ETH_DMAOMR	Reserved						DTCEFD	RSF	DFRF	Reserved	TSF	FTF	Reserved	TTC	ST	Reserved				FEF	FUGF	Reserved	RTC	OSF	SR	Reserved						
	Reset value	0	0	0	0	0	0	0	0	0	0	0	0	0	0	0	0	0	0	0	0	0	0	0	0	0	0	0	0	0	0	0	0
0x101C	ETH_DMAIER	Reserved														NISE	AISE	ERIE	FBEIE	Reserved	ETIE	RWTIE	RPSIE	RBUIE	RIE	TUIE	ROIIE	TJTIE	TBUIE	TPSIE	TIE		
	Reset value	0	0	0	0	0	0	0	0	0	0	0	0	0	0	0	0	0	0	0	0	0	0	0	0	0	0	0	0	0	0	0	0
0x1020	ETH_DMAMFBOCR	Reserved	OFOC	MFA												OMFC	MFC																
	Reset value	0	0	0	0	0	0	0	0	0	0	0	0	0	0	0	0	0	0	0	0	0	0	0	0	0	0	0	0	0	0	0	0
0x1048	ETH_DMACHTDR	HTDAP																															
	Reset value	0	0	0	0	0	0	0	0	0	0	0	0	0	0	0	0	0	0	0	0	0	0	0	0	0	0	0	0	0	0	0	0
0x104C	ETH_DMACHRDR	HRDAP																															
	Reset value	0	0	0	0	0	0	0	0	0	0	0	0	0	0	0	0	0	0	0	0	0	0	0	0	0	0	0	0	0	0	0	0
0x1050	ETH_DMACHTBR	HTBAP																															
	Reset value	0	0	0	0	0	0	0	0	0	0	0	0	0	0	0	0	0	0	0	0	0	0	0	0	0	0	0	0	0	0	0	0
0x1054	ETH_DMACHRBR	HRBAP																															
	Reset value	0	0	0	0	0	0	0	0	0	0	0	0	0	0	0	0	0	0	0	0	0	0	0	0	0	0	0	0	0	0	0	0

Refer to [Table 1 on page 44](#) for the register boundary addresses.

## 29 Device electronic signature

**Low-density devices** are STM32F101xx, STM32F102xx and STM32F103xx microcontrollers where the Flash memory density ranges between 16 and 32 Kbytes.

**Medium-density devices** are STM32F101xx, STM32F102xx and STM32F103xx microcontrollers where the Flash memory density ranges between 64 and 128 Kbytes.

**High-density devices** are STM32F101xx and STM32F103xx microcontrollers where the Flash memory density ranges between 256 and 512 Kbytes.

**XL-density devices** are STM32F101xx and STM32F103xx microcontrollers where the Flash memory density ranges between 768 Kbytes and 1 Mbyte.

**Connectivity line devices** are STM32F105xx and STM32F107xx microcontrollers.

This Section applies to the whole STM32F10xxx family, unless otherwise specified.

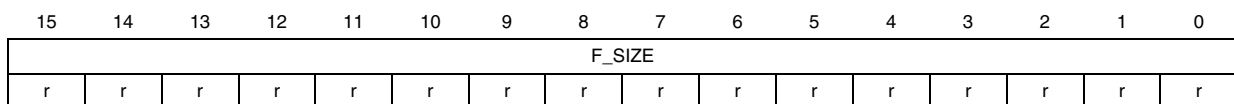
The electronic signature is stored in the System memory area in the Flash memory module, and can be read using the JTAG/SWD or the CPU. It contains factory-programmed identification data that allow the user firmware or other external devices to automatically match its interface to the characteristics of the STM32F10xxx microcontroller.

### 29.1 Memory size registers

#### 29.1.1 Flash size register

Base address: 0x1FFF F7E0

Read only = 0xXXXX where X is factory-programmed



Bits 15:0 **F\_SIZE**: Flash memory size

This field value indicates the Flash memory size of the device in Kbytes.

Example: 0x0080 = 128 Kbytes.



## 29.2 Unique device ID register (96 bits)

The unique device identifier is ideally suited:

- for use as serial numbers (for example USB string serial numbers or other end applications)
- for use as security keys in order to increase the security of code in Flash memory while using and combining this unique ID with software cryptographic primitives and protocols before programming the internal Flash memory
- to activate secure boot processes, etc.

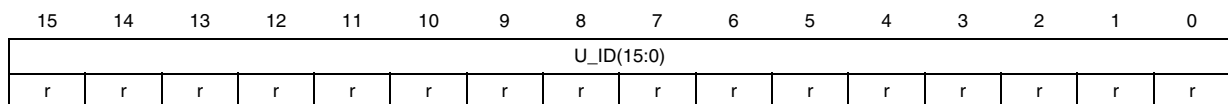
The 96-bit unique device identifier provides a reference number which is unique for any device and in any context. These bits can never be altered by the user.

The 96-bit unique device identifier can also be read in single bytes/half-words/words in different ways and then be concatenated using a custom algorithm.

### Base address: 0x1FFF F7E8

Address offset: 0x00

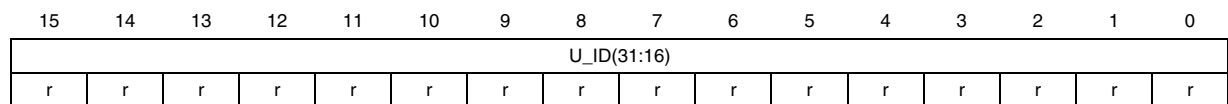
Read only = 0xXXXX where X is factory-programmed



Bits 15:0 **U\_ID(15:0)**: 15:0 unique ID bits

Address offset: 0x02

Read only = 0xXXXX where X is factory-programmed

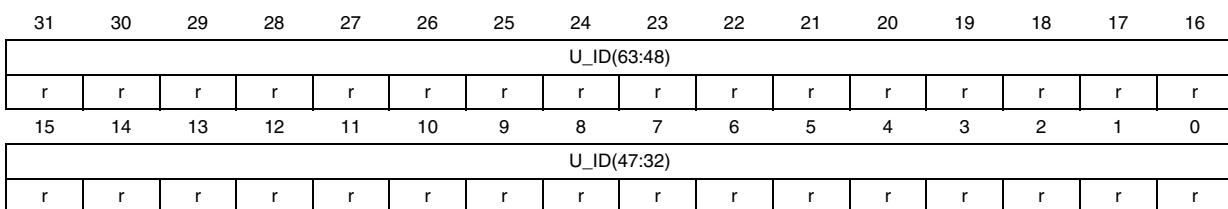


Bits 15:0 **U\_ID(31:16)**: 31:16 unique ID bits

This field value is also reserved for a future feature.

Address offset: 0x04

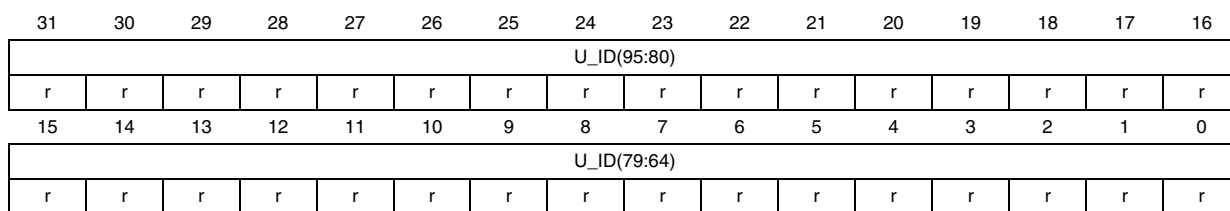
Read only = 0xXXXX XXXX where X is factory-programmed



Bits 31:0 **U\_ID(63:32)**: 63:32 unique ID bits

Address offset: 0x08

Read only = 0xXXXX XXXX where X is factory-programmed



Bits 31:0 **U\_ID(95:64)**: 95:64 Unique ID bits.

## 30 Debug support (DBG)

**Low-density devices** are STM32F101xx, STM32F102xx and STM32F103xx microcontrollers where the Flash memory density ranges between 16 and 32 Kbytes.

**Medium-density devices** are STM32F101xx, STM32F102xx and STM32F103xx microcontrollers where the Flash memory density ranges between 64 and 128 Kbytes.

**High-density devices** are STM32F101xx and STM32F103xx microcontrollers where the Flash memory density ranges between 256 and 512 Kbytes.

**XL-density devices** are STM32F101xx and STM32F103xx microcontrollers where the Flash memory density ranges between 768 Kbytes and 1 Mbyte.

**Connectivity line devices** are STM32F105xx and STM32F107xx microcontrollers.

This section applies to the whole STM32F10xxx family, unless otherwise specified.

### 30.1 Overview

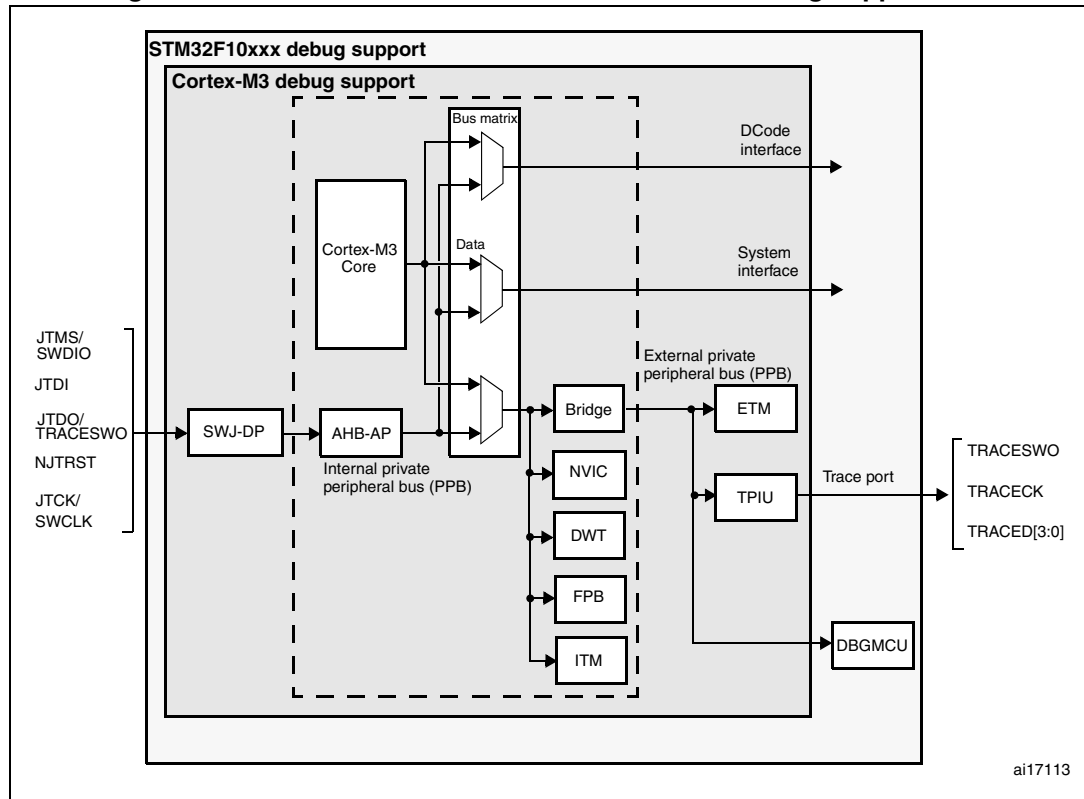
The STM32F10xxx are built around a Cortex-M3 core which contains hardware extensions for advanced debugging features. The debug extensions allow the core to be stopped either on a given instruction fetch (breakpoint) or data access (watchpoint). When stopped, the core's internal state and the system's external state may be examined. Once examination is complete, the core and the system may be restored and program execution resumed.

The debug features are used by the debugger host when connecting to and debugging the STM32F10xxx MCUs.

Two interfaces for debug are available:

- Serial wire
- JTAG debug port

Figure 361. Block diagram of STM32F10xxx-level and Cortex-M3-level debug support



Note: The debug features embedded in the Cortex-M3 core are a subset of the ARM CoreSight Design Kit.

The ARM Cortex-M3 core provides integrated on-chip debug support. It is comprised of:

- SWJ-DP: Serial wire / JTAG debug port
- AHP-AP: AHB access port
- ITM: Instrumentation trace macrocell
- FPB: Flash patch breakpoint
- DWT: Data watchpoint trigger
- TPUI: Trace port unit interface (available on larger packages, where the corresponding pins are mapped)
- ETM: Embedded Trace Macrocell (available on larger packages, where the corresponding pins are mapped)

It also includes debug features dedicated to STM32F10xxx:

- Flexible debug pinout assignment
- MCU debug box (support for low-power modes, control over peripheral clocks, etc.)

Note: For further information on debug functionality supported by the ARM Cortex-M3 core, refer to the Cortex-M3-r1p1 Technical Reference Manual and to the CoreSight Design Kit-r1p0 TRM (see [Section 30.2: Reference ARM documentation](#)).

### 30.2 Reference ARM documentation

- Cortex™-M3 r1p1 Technical Reference Manual (TRM)  
It is available from:  
[http://infocenter.arm.com/help/topic/com.arm.doc.ddi0337e/DDI0337E\\_cortex\\_m3\\_r1p1\\_trm.pdf](http://infocenter.arm.com/help/topic/com.arm.doc.ddi0337e/DDI0337E_cortex_m3_r1p1_trm.pdf)
- ARM Debug Interface V5
- ARM CoreSight Design Kit revision r1p1 Technical Reference Manual

### 30.3 SWJ debug port (serial wire and JTAG)

The STM32F10xxx core integrates the Serial Wire / JTAG Debug Port (SWJ-DP). It is an ARM standard CoreSight debug port that combines a JTAG-DP (5-pin) interface and a SW-DP (2-pin) interface.

- The JTAG Debug Port (JTAG-DP) provides a 5-pin standard JTAG interface to the AHP-AP port.
- The Serial Wire Debug Port (SW-DP) provides a 2-pin (clock + data) interface to the AHP-AP port.

In the SWJ-DP, the two JTAG pins of the SW-DP are multiplexed with some of the five JTAG pins of the JTAG-DP.

**Figure 362. SWJ debug port**

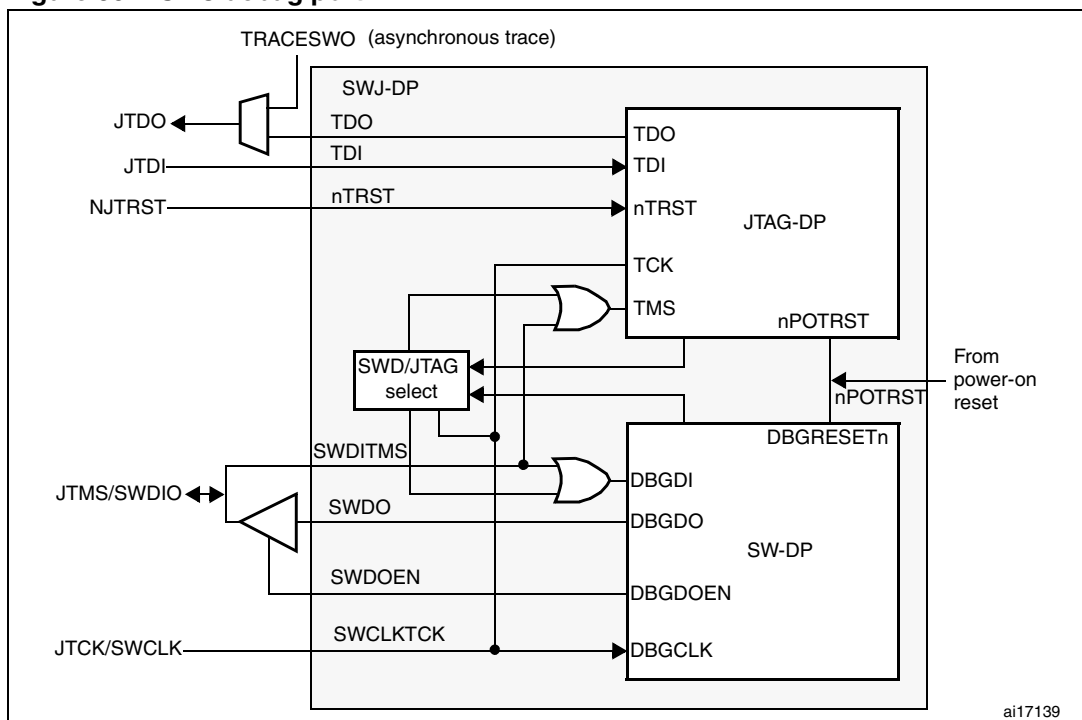


Figure 362 shows that the asynchronous TRACE output (TRACESWO) is multiplexed with TDO. This means that the asynchronous trace can only be used with SW-DP, not JTAG-DP.

#### 30.3.1 Mechanism to select the JTAG-DP or the SW-DP

By default, the JTAG-Debug Port is active.

If the debugger host wants to switch to the SW-DP, it must provide a dedicated JTAG sequence on TMS/TCK (respectively mapped to SWDIO and SWCLK) which disables the JTAG-DP and enables the SW-DP. This way it is possible to activate the SWDP using only the SWCLK and SWDIO pins.

This sequence is:

1. Send more than 50 TCK cycles with TMS (SWDIO) =1
2. Send the 16-bit sequence on TMS (SWDIO) = 0111100111100111 (MSB transmitted first)
3. Send more than 50 TCK cycles with TMS (SWDIO) =1

### 30.4 Pinout and debug port pins

The STM32F10xxx MCUs are available in various packages with different numbers of available pins. As a result, some functionality (ETM) related to pin availability may differ between packages.

#### 30.4.1 SWJ debug port pins

Five pins are used as outputs from the STM32F10xxx for the SWJ-DP as *alternate functions* of general-purpose I/Os. These pins are available on all packages.

**Table 213. SWJ debug port pins**

SWJ-DP pin name	JTAG debug port		SW debug port		Pin assignment
	Type	Description	Type	Debug assignment	
JTMS/SWDIO	I	JTAG Test Mode Selection	IO	Serial Wire Data Input/Output	PA13
JTCK/SWCLK	I	JTAG Test Clock	I	Serial Wire Clock	PA14
JTDI	I	JTAG Test Data Input	-	-	PA15
JTDO/TRACESWO	O	JTAG Test Data Output	-	TRACESWO if async trace is enabled	PB3
NJTRST	I	JTAG Test nReset	-	-	PB4

#### 30.4.2 Flexible SWJ-DP pin assignment

After RESET (SYSRESETn or PORESETn), all five pins used for the SWJ-DP are assigned as dedicated pins immediately usable by the debugger host (note that the trace outputs are not assigned except if explicitly programmed by the debugger host).

However, the STM32F10xxx MCU implements the [AF remap and debug I/O configuration register \(AFIO\\_MAPPR\)](#) register to disable some part or all of the SWJ-DP port and so releases the associated pins for General Purpose I/Os usage. This register is mapped on an APB bridge connected to the Cortex-M3 System Bus. Programming of this register is done by the user software program and not the debugger host.

Three control bits allow the configuration of the SWJ-DP pin assignments. These bits are reset by the System Reset.

- AFIO\_MAPR (@ 0x40010004 in STM32F10xxx MCU)
  - READ: APB - No Wait State
  - WRITE: APB - 1 Wait State if the write buffer of the AHB-APB bridge is full.

Bit 26:24= **SWJ\_CFG[2:0]**

Set and cleared by software.

These bits are used to configure the number of pins assigned to the SWJ debug port. The goal is to release as much as possible the number of pins to be used as General Purpose IOs if using a small size for the debug port.

The default state after reset is “000” (whole pins assigned for a full JTAG-DP connection). Only one of the 3 bits can be set (it is forbidden to set more than one bit).

**Table 214. Flexible SWJ-DP pin assignment**

Available debug ports	SWJ IO pin assigned				
	PA13 / JTMS / SWDIO	PA14 / JTCK / SWCLK	PA15 / JTDI	PB3 / JTDO	PB4 / NJTRST
Full SWJ (JTAG-DP + SW-DP) - Reset State	X	X	X	X	X
Full SWJ (JTAG-DP + SW-DP) but without NJTRST	X	X	X	X	
JTAG-DP Disabled and SW-DP Enabled	X	X			
JTAG-DP Disabled and SW-DP Disabled	Released				

*Note:* When the APB bridge write buffer is full, it takes one extra APB cycle when writing the AFIO\_MAPR register. This is because the deactivation of the JTAGSW pins is done in two cycles to guarantee a clean level on the nTRST and TCK input signals of the core.

- Cycle 1: the JTAGSW input signals to the core are tied to 1 or 0 (to 1 for nTRST, TDI and TMS, to 0 for TCK)
- Cycle 2: the GPIO controller takes the control signals of the SWJTAG IO pins (like controls of direction, pull-up/down, Schmitt trigger activation, etc.).

### 30.4.3 Internal pull-up and pull-down on JTAG pins

It is necessary to ensure that the JTAG input pins are not floating since they are directly connected to flip-flops to control the debug mode features. Special care must be taken with the SWCLK/TCK pin which is directly connected to the clock of some of these flip-flops.

To avoid any uncontrolled IO levels, the STM32F10xxx embed internal pull-ups and pull-downs on JTAG input pins:

- NJTRST: Internal pull-up
- JTDI: Internal pull-up
- JTMS/SWDIO: Internal pull-up
- TCK/SWCLK: Internal pull-down

Once a JTAG IO is released by the user software, the GPIO controller takes control again. The reset states of the GPIO control registers put the IOs in the equivalent state:

- NJTRST: Input pull-up
- JTDI: Input pull-up
- JTMS/SWDIO: Input pull-up
- JTCK/SWCLK: Input pull-down
- JTDO: Input floating

The software can then use these IOs as standard GPIOs.

*Note: The JTAG IEEE standard recommends to add pull-ups on TDI, TMS and nTRST but there is no special recommendation for TCK. However, for STM32F10xxx, an integrated pull-down is used for JTCK.*

*Having embedded pull-ups and pull-downs removes the need to add external resistors.*

### 30.4.4 Using serial wire and releasing the unused debug pins as GPIOs

To use the serial wire DP to release some GPIOs, the user software must set SWJ\_CFG=010 just after reset. This releases PA15, PB3 and PB4 which now become available as GPIOs.

When debugging, the host performs the following actions:

- Under system reset, all SWJ pins are assigned (JTAG-DP + SW-DP).
- Under system reset, the debugger host sends the JTAG sequence to switch from the JTAG-DP to the SW-DP.
- Still under system reset, the debugger sets a breakpoint on vector reset.
- The system reset is released and the Core halts.
- All the debug communications from this point are done using the SW-DP. The other JTAG pins can then be reassigned as GPIOs by the user software.

*Note: For user software designs, note that:*

*To release the debug pins, remember that they will be first configured either in input-pull-up (nTRST, TMS, TDI) or pull-down (TCK) or output tristate (TDO) for a certain duration after reset until the instant when the user software releases the pins.*

*When debug pins (JTAG or SW or TRACE) are mapped, changing the corresponding IO pin configuration in the IOPORT controller has no effect.*

## 30.5 STM32F10xxx JTAG TAP connection

The STM32F10xxx MCUs integrate two serially connected JTAG TAPs, the boundary scan TAP (IR is 5-bit wide) and the Cortex-M3 TAP (IR is 4-bit wide).

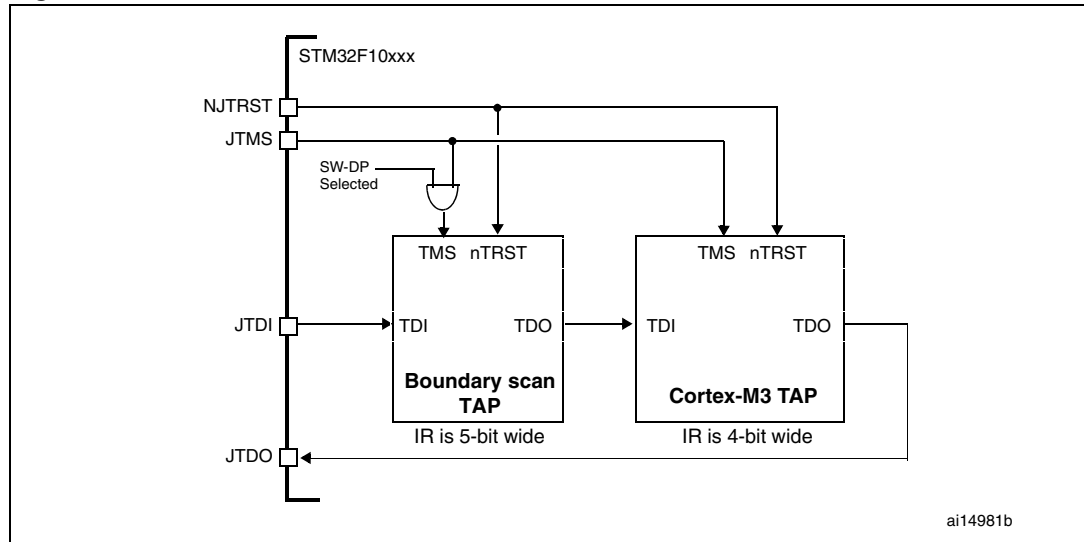
To access the TAP of the Cortex-M3 for debug purposes:

1. First, it is necessary to shift the BYPASS instruction of the boundary scan TAP.
2. Then, for each IR shift, the scan chain contains 9 bits (=5+4) and the unused TAP instruction must be shifted in using the BYPASS instruction.
3. For each data shift, the unused TAP, which is in BYPASS mode, adds 1 extra data bit in the data scan chain.



Note: **Important:** Once Serial-Wire is selected using the dedicated ARM JTAG sequence, the boundary scan TAP is automatically disabled (JTMS forced high).

Figure 363. JTAG TAP connections



## 30.6 ID codes and locking mechanism

There are several ID codes inside the STM32F10xxx MCUs. ST strongly recommends tools designers to lock their debuggers using the MCU DEVICE ID code located in the external PPB memory map at address 0xE0042000.

### 30.6.1 MCU device ID code

The STM32F10xxx MCUs integrate an MCU ID code. This ID identifies the ST MCU part-number and the die revision. It is part of the DBG\_MCU component and is mapped on the external PPB bus (see [Section 30.16 on page 1046](#)). This code is accessible using the JTAG debug port (4 to 5 pins) or the SW debug port (two pins) or by the user software. It is even accessible while the MCU is under system reset.

**DBGMCU\_IDCODE**

Address: 0xE0042000

Only 32-bits access supported. Read-only.

31	30	29	28	27	26	25	24	23	22	21	20	19	18	17	16	
REV_ID																
r	r	r	r	r	r	r	r	r	r	r	r	r	r	r	r	
15	14	13	12	11	10	9	8	7	6	5	4	3	2	1	0	
Reserved				DEV_ID												
				r	r	r	r	r	r	r	r	r	r	r	r	r

**Bits 31:16 REV\_ID(15:0)** Revision identifier

This field indicates the revision of the device:

In low-density devices:

- 0x1000 = Revision A

In medium-density devices:

- 0x0000 = Revision A
- 0x2000 = Revision B
- 0x2001 = Revision Z
- 0x2003 = Revision Y

In high-density devices:

- 0x1000 = Revision A
- 0x1001 = Revision Z
- 0x1003 = Revision Y

In XL-density devices:

- 0x1000 = Revision A

In connectivity line devices:

- 0x1000 = Revision A
- 0x1001 = Revision Z

**Bits 15:12** Reserved

**Bits 11:0 DEV\_ID(11:0):** Device identifier

This field indicates the device ID.

For low-density devices, the device ID is 0x412

For medium-density devices, the device ID is 0x410

For high-density devices, the device ID is 0x414

For XL-density devices, the device ID is 0x430

For connectivity devices, the device ID is 0x418

## 30.6.2 Boundary scan TAP

### JTAG ID code

The TAP of the STM32F10xxx BSC (boundary scan) integrates a JTAG ID code equal to:

- In low-density devices:
  - 0x06412041 = Revision A
- In medium-density devices:
  - 0x06410041 = Revision A
  - 0x16410041 = Revision B, Revision Z and Revision Y
- In high-density devices:
  - 0x06414041 = Revision A, Revision Z and Revision Y
- In XL-density devices
  - 0x06430041 = Revision A
- In connectivity line devices:
  - 0x06418041 = Revision A and Revision Z

## 30.6.3 Cortex-M3 TAP

The TAP of the ARM Cortex-M3 integrates a JTAG ID code. This ID code is the ARM default one and has not been modified. This code is only accessible by the JTAG Debug Port. This code is **0x3BA00477** (corresponds to Cortex-M3 r1p1-01rel0, see [Section 30.2: Reference ARM documentation](#)).

Only the DEV\_ID(11:0) should be used for identification by the debugger/programmer tools.

## 30.6.4 Cortex-M3 JEDEC-106 ID code

The ARM Cortex-M3 integrates a JEDEC-106 ID code. It is located in the 4KB ROM table mapped on the internal PPB bus at address 0xE00FF000\_0xE00FFFFF.

This code is accessible by the JTAG Debug Port (4 to 5 pins) or by the SW Debug Port (two pins) or by the user software.

## 30.7 JTAG debug port

A standard JTAG state machine is implemented with a 4-bit instruction register (IR) and five data registers (for full details, refer to the *Cortex-M3 r1p1 Technical Reference Manual (TRM)*, for references, please see [Section 30.2: Reference ARM documentation](#)).

**Table 215. JTAG debug port data registers**

IR(3:0)	Data register	Details
1111	BYPASS [1 bit]	
1110	IDCODE [32 bits]	<i>ID CODE</i> 0x3BA00477 (ARM Cortex-M3 r1p1-01rel0 ID Code)

**Table 215. JTAG debug port data registers (continued)**

IR(3:0)	Data register	Details
1010	DPACC [35 bits]	<p><i>Debug port access register</i></p> <p>This initiates a debug port and allows access to a debug port register.</p> <ul style="list-style-type: none"> <li>- When transferring data IN:                             <ul style="list-style-type: none"> <li>Bits 34:3 = DATA[31:0] = 32-bit data to transfer for a write request</li> <li>Bits 2:1 = A[3:2] = 2-bit address of a debug port register.</li> <li>Bit 0 = RnW = Read request (1) or write request (0).</li> </ul> </li> <li>- When transferring data OUT:                             <ul style="list-style-type: none"> <li>Bits 34:3 = DATA[31:0] = 32-bit data which is read following a read request</li> <li>Bits 2:0 = ACK[2:0] = 3-bit Acknowledge:                                     <ul style="list-style-type: none"> <li>010 = OK/FAULT</li> <li>001 = WAIT</li> <li>OTHER = reserved</li> </ul> </li> </ul> </li> </ul> <p>Refer to <a href="#">Table 216</a> for a description of the A(3:2) bits</p>
1011	APACC [35 bits]	<p><i>Access port access register</i></p> <p>Initiates an access port and allows access to an access port register.</p> <ul style="list-style-type: none"> <li>- When transferring data IN:                             <ul style="list-style-type: none"> <li>Bits 34:3 = DATA[31:0] = 32-bit data to shift in for a write request</li> <li>Bits 2:1 = A[3:2] = 2-bit address (sub-address AP registers).</li> <li>Bit 0 = RnW= Read request (1) or write request (0).</li> </ul> </li> <li>- When transferring data OUT:                             <ul style="list-style-type: none"> <li>Bits 34:3 = DATA[31:0] = 32-bit data which is read following a read request</li> <li>Bits 2:0 = ACK[2:0] = 3-bit Acknowledge:                                     <ul style="list-style-type: none"> <li>010 = OK/FAULT</li> <li>001 = WAIT</li> <li>OTHER = reserved</li> </ul> </li> </ul> </li> </ul> <p>There are many AP Registers (see AHB-AP) addressed as the combination of:</p> <ul style="list-style-type: none"> <li>- The shifted value A[3:2]</li> <li>- The current value of the DP SELECT register</li> </ul>
1000	ABORT [35 bits]	<p><i>Abort register</i></p> <ul style="list-style-type: none"> <li>- Bits 31:1 = Reserved</li> <li>- Bit 0 = DAPABORT: write 1 to generate a DAP abort.</li> </ul>

**Table 216. 32-bit debug port registers addressed through the shifted value A[3:2]**

Address	A(3:2) value	Description
0x0	00	Reserved
0x4	01	DP CTRL/STAT register. Used to: <ul style="list-style-type: none"> <li>– Request a system or debug power-up</li> <li>– Configure the transfer operation for AP accesses</li> <li>– Control the pushed compare and pushed verify operations.</li> <li>– Read some status flags (overrun, power-up acknowledges)</li> </ul>
0x8	10	DP SELECT register: Used to select the current access port and the active 4-words register window. <ul style="list-style-type: none"> <li>– Bits 31:24: APSEL: select the current AP</li> <li>– Bits 23:8: reserved</li> <li>– Bits 7:4: APBANKSEL: select the active 4-words register window on the current AP</li> <li>– Bits 3:0: reserved</li> </ul>
0xC	11	DP RDBUFF register: Used to allow the debugger to get the final result after a sequence of operations (without requesting new JTAG-DP operation)

## 30.8 SW debug port

### 30.8.1 SW protocol introduction

This synchronous serial protocol uses two pins:

- SWCLK: clock from host to target
- SWDIO: bidirectional

The protocol allows two banks of registers (DPACC registers and APACC registers) to be read and written to.

Bits are transferred LSB-first on the wire.

For SWDIO bidirectional management, the line must be pulled-up on the board (100 K $\Omega$  recommended by ARM).

Each time the direction of SWDIO changes in the protocol, a turnaround time is inserted where the line is not driven by the host nor the target. By default, this turnaround time is one bit time, however this can be adjusted by configuring the SWCLK frequency.

### 30.8.2 SW protocol sequence

Each sequence consist of three phases:

1. Packet request (8 bits) transmitted by the host
2. Acknowledge response (3 bits) transmitted by the target
3. Data transfer phase (33 bits) transmitted by the host or the target

**Table 217. Packet request (8-bits)**

Bit	Name	Description
0	Start	Must be “1”
1	APnDP	0: DP Access 1: AP Access
2	RnW	0: Write Request 1: Read Request
4:3	A(3:2)	Address field of the DP or AP registers (refer to <a href="#">Table 216</a> )
5	Parity	Single bit parity of preceding bits
6	Stop	0
7	Park	Not driven by the host. Must be read as “1” by the target because of the pull-up

Refer to the *Cortex-M3 r1p1 TRM* for a detailed description of DPACC and APACC registers. The packet request is always followed by the turnaround time (default 1 bit) where neither the host nor target drive the line.

**Table 218. ACK response (3 bits)**

Bit	Name	Description
0..2	ACK	001: FAULT 010: WAIT 100: OK

The ACK Response must be followed by a turnaround time only if it is a READ transaction or if a WAIT or FAULT acknowledge has been received.

**Table 219. DATA transfer (33 bits)**

Bit	Name	Description
0..31	WDATA or RDATA	Write or Read data
32	Parity	Single parity of the 32 data bits

The DATA transfer must be followed by a turnaround time only if it is a READ transaction.

### 30.8.3 SW-DP state machine (Reset, idle states, ID code)

The State Machine of the SW-DP has an internal ID code which identifies the SW-DP. It follows the JEP-106 standard. This ID code is the default ARM one and is set to **0x1BA01477** (corresponding to Cortex-M3 r1p1).

*Note:* Note that the SW-DP state machine is inactive until the target reads this ID code.

- The SW-DP state machine is in RESET STATE either after power-on reset, or after the DP has switched from JTAG to SWD or after the line is high for more than 50 cycles
- The SW-DP state machine is in IDLE STATE if the line is low for at least two cycles after RESET state.
- After RESET state, it is **mandatory** to first enter into an IDLE state AND to perform a READ access of the DP-SW ID CODE register. Otherwise, the target will issue a FAULT acknowledge response on another transactions.

Further details of the SW-DP state machine can be found in the *Cortex-M3 r1p1 TRM* and the *CoreSight Design Kit r1p0 TRM*.

### 30.8.4 DP and AP read/write accesses

- Read accesses to the DP are not posted: the target response can be immediate (if ACK=OK) or can be delayed (if ACK=WAIT).
- Read accesses to the AP are posted. This means that the result of the access is returned on the next transfer. If the next access to be done is NOT an AP access, then the DP-RDBUFF register must be read to obtain the result. The READOK flag of the DP-CTRL/STAT register is updated on every AP read access or RDBUFF read request to know if the AP read access was successful.
- The SW-DP implements a write buffer (for both DP or AP writes), that enables it to accept a write operation even when other transactions are still outstanding. If the write buffer is full, the target acknowledge response is "WAIT". With the exception of IDCODE read or CTRL/STAT read or ABORT write which are accepted even if the write buffer is full.
- Because of the asynchronous clock domains SWCLK and HCLK, two extra SWCLK cycles are needed after a write transaction (after the parity bit) to make the write effective internally. These cycles should be applied while driving the line low (IDLE state)  
This is particularly important when writing the CTRL/STAT for a power-up request. If the next transaction (requiring a power-up) occurs immediately, it will fail.

### 30.8.5 SW-DP registers

Access to these registers are initiated when APnDP=0

**Table 220. SW-DP registers**

A(3:2)	R/W	CTRLSEL bit of SELECT register	Register	Notes
00	Read		IDCODE	The manufacturer code is not set to ST code. <b>0x1BA01477</b> (identifies the SW-DP)
00	Write		ABORT	

**Table 220. SW-DP registers (continued)**

A(3:2)	R/W	CTRLSEL bit of SELECT register	Register	Notes
01	Read/Write	0	DP-CTRL/STAT	Purpose is to: – request a system or debug power-up – configure the transfer operation for AP accesses – control the pushed compare and pushed verify operations. – read some status flags (overrun, power-up acknowledges)
01	Read/Write	1	WIRE CONTROL	Purpose is to configure the physical serial port protocol (like the duration of the turnaround time)
10	Read		READ RESEND	Enables recovery of the read data from a corrupted debugger transfer, without repeating the original AP transfer.
10	Write		SELECT	The purpose is to select the current access port and the active 4-words register window
11	Read/Write		READ BUFFER	This read buffer is useful because AP accesses are posted (the result of a read AP request is available on the next AP transaction). This read buffer captures data from the AP, presented as the result of a previous read, without initiating a new transaction

### 30.8.6 SW-AP registers

Access to these registers are initiated when APnDP=1

There are many AP Registers (see AHB-AP) addressed as the combination of:

- The shifted value A[3:2]
- The current value of the DP SELECT register

## 30.9 AHB-AP (AHB access port) - valid for both JTAG-DP or SW-DP

### Features:

- System access is independent of the processor status.
- Either SW-DP or JTAG-DP accesses AHB-AP.
- The AHB-AP is an AHB master into the Bus Matrix. Consequently, it can access all the data buses (Dcode Bus, System Bus, internal and external PPB bus) but the ICode bus.
- Bitband transactions are supported.
- AHB-AP transactions bypass the FPB.



The address of the 32-bits AHB-AP registers are 6-bits wide (up to 64 words or 256 bytes) and consists of:

- c) Bits [7:4] = the bits [7:4] APBANKSEL of the DP SELECT register
- d) Bits [3:2] = the 2 address bits of A(3:2) of the 35-bit packet request for SW-DP.

The AHB-AP of the Cortex-M3 includes 9 x 32-bits registers:

**Table 221. Cortex-M3 AHB-AP registers**

Address offset	Register name	Notes
0x00	AHB-AP Control and Status Word	Configures and controls transfers through the AHB interface (size, hprot, status on current transfer, address increment type)
0x04	AHB-AP Transfer Address	
0x0C	AHB-AP Data Read/Write	
0x10	AHB-AP Banked Data 0	Directly maps the 4 aligned data words without rewriting the Transfer Address Register.
0x14	AHB-AP Banked Data 1	
0x18	AHB-AP Banked Data 2	
0x1C	AHB-AP Banked Data 3	
0xF8	AHB-AP Debug ROM Address	Base Address of the debug interface
0xFC	AHB-AP ID Register	

Refer to the *Cortex-M3 r1p1 TRM* for further details.

## 30.10 Core debug

Core debug is accessed through the core debug registers. Debug access to these registers is by means of the *Advanced High-performance Bus (AHB-AP)* port. The processor can access these registers directly over the internal *Private Peripheral Bus (PPB)*.

It consists of 4 registers:

**Table 222. Core debug registers**

Register	Description
DHCSR	<i>The 32-bit Debug Halting Control and Status Register</i> This provides status information about the state of the processor enable core debug halt and step the processor
DCRSR	<i>The 17-bit Debug Core Register Selector Register:</i> This selects the processor register to transfer data to or from.
DCRDR	<i>The 32-bit Debug Core Register Data Register:</i> This holds data for reading and writing registers to and from the processor selected by the DCRSR (Selector) register.
DEMCR	<i>The 32-bit Debug Exception and Monitor Control Register:</i> This provides Vector Catching and Debug Monitor Control. This register contains a bit named <b>TRCENA</b> which enable the use of a TRACE.

*Note:* **Important:** these registers are not reset by a system reset. They are only reset by a power-on reset.

Refer to the *Cortex-M3 r1p1 TRM* for further details.

To Halt on reset, it is necessary to:

- enable the bit0 (VC\_CORRESET) of the Debug and Exception Monitor Control Register
- enable the bit0 (C\_DEBUGEN) of the Debug Halting Control and Status Register.

## 30.11 Capability of the debugger host to connect under system reset

The STM32F10xxx MCUs' reset system comprises the following reset sources:

- POR (power-on reset) which asserts a RESET at each power-up.
- Internal watchdog reset
- Software reset
- External reset

The Cortex-M3 differentiates the reset of the debug part (generally PORRESETn) and the other one (SYSRESETn)

This way, it is possible for the debugger to connect under System Reset, programming the Core Debug Registers to halt the core when fetching the reset vector. Then the host can release the system reset and the core will immediately halt without having executed any instructions. In addition, it is possible to program any debug features under System Reset.

*Note:* It is highly recommended for the debugger host to connect (set a breakpoint in the reset vector) under system reset.

## 30.12 FPB (Flash patch breakpoint)

The FPB unit:

- implements hardware breakpoints
- patches code and data from code space to system space. This feature gives the possibility to correct software bugs located in the Code Memory Space.

The use of a Software Patch or a Hardware Breakpoint is exclusive.

The FPB consists of:

- 2 literal comparators for matching against literal loads from Code Space and remapping to a corresponding area in the System Space.
- 6 instruction comparators for matching against instruction fetches from Code Space. They can be used either to remap to a corresponding area in the System Space or to generate a Breakpoint Instruction to the core.

## 30.13 DWT (data watchpoint trigger)

The DWT unit consists of four comparators. They are configurable as:

- a hardware watchpoint or
- a trigger to an ETM or
- a PC sampler or
- a data address sampler

The DWT also provides some means to give some profiling informations. For this, some counters are accessible to give the number of:

- Clock cycle
- Folded instructions
- Load store unit (LSU) operations
- Sleep cycles
- CPI (clock per instructions)
- Interrupt overhead

## 30.14 ITM (instrumentation trace macrocell)

### 30.14.1 General description

The ITM is an application-driven trace source that supports *printf* style debugging to trace *Operating System* (OS) and application events, and emits diagnostic system information. The ITM emits trace information as packets which can be generated as:

- **Software trace.** Software can write directly to the ITM stimulus registers to emit packets.
- **Hardware trace.** The DWT generates these packets, and the ITM emits them.
- **Time stamping.** Timestamps are emitted relative to packets. The ITM contains a 21-bit counter to generate the timestamp. The Cortex-M3 clock or the bit clock rate of the *Serial Wire Viewer* (SWV) output clocks the counter.

The packets emitted by the ITM are output to the TPIU (Trace Port Interface Unit). The formatter of the TPIU adds some extra packets (refer to TPIU) and then output the complete packets sequence to the debugger host.

The bit TRCEN of the Debug Exception and Monitor Control Register must be enabled before you program or use the ITM.

### 30.14.2 Time stamp packets, synchronization and overflow packets

Time stamp packets encode time stamp information, generic control and synchronization. It uses a 21-bit timestamp counter (with possible prescalers) which is reset at each time stamp packet emission. This counter can be either clocked by the CPU clock or the SWV clock.

A synchronization packet consists of 6 bytes equal to 0x80\_00\_00\_00\_00\_00 which is emitted to the TPIU as 00 00 00 00 00 80 (LSB emitted first).

A synchronization packet is a timestamp packet control. It is emitted at each DWT trigger.

For this, the DWT must be configured to trigger the ITM: the bit CYCCNTENA (bit0) of the DWT Control Register must be set. In addition, the bit2 (SYNCENA) of the ITM Trace Control Register must be set.

*Note: If the SYNENA bit is not set, the DWT generates Synchronization triggers to the TPIU which will send only TPIU synchronization packets and not ITM synchronization packets.*

An overflow packet consists is a special timestamp packets which indicates that data has been written but the FIFO was full.

**Table 223. Main ITM registers**

Address	Register	Details
@E0000FB0	ITM lock access	Write 0xC5ACCE55 to unlock Write Access to the other ITM registers
@E0000E80	ITM trace control	Bits 31-24 = Always 0
		Bits 23 = Busy
		Bits 22-16 = 7-bits ATB ID which identifies the source of the trace data.
		Bits 15-10 = Always 0
		Bits 9:8 = TSPrescale = Time Stamp Prescaler
		Bits 7-5 = Reserved
		Bit 4 = SWOENA = Enable SWV behavior (to clock the timestamp counter by the SWV clock).
		Bit 3 = DWTENA: Enable the DWT Stimulus
		Bit 2 = SYNCENA: this bit must be to 1 to enable the DWT to generate synchronization triggers so that the TPIU can then emit the synchronization packets.
		Bit 1 = TSENA (Timestamp Enable)
Bit 0 = ITMENA: Global Enable Bit of the ITM		
@E0000E40	ITM trace privilege	Bit 3: mask to enable tracing ports31:24
		Bit 2: mask to enable tracing ports23:16
		Bit 1: mask to enable tracing ports15:8
		Bit 0: mask to enable tracing ports7:0
@E0000E00	ITM trace enable	Each bit enables the corresponding Stimulus port to generate trace.
@E0000000- E000007C	Stimulus port registers 0-31	Write the 32-bits data on the selected Stimulus Port (32 available) to be traced out.

### Example of configuration

To output a simple value to the TPIU:

- Configure the TPIU and assign TRACE IOs by configuring the DBGMCU\_CR (refer to [Section 30.17.2: TRACE pin assignment](#) and [Section 30.16.3: Debug MCU configuration register](#))
- Write 0xC5ACCE55 to the ITM Lock Access Register to unlock the write access to the ITM registers
- Write 0x00010005 to the ITM Trace Control Register to enable the ITM with Sync enabled and an ATB ID different from 0x00
- Write 0x1 to the ITM Trace Enable Register to enable the Stimulus Port 0
- Write 0x1 to the ITM Trace Privilege Register to unmask stimulus ports 7:0
- Write the value to output in the Stimulus Port Register 0: this can be done by software (using a printf function)

## 30.15 ETM (Embedded Trace Macrocell)

### 30.15.1 General description

The ETM enables the reconstruction of program execution. Data are traced using the Data Watchpoint and Trace (DWT) component or the Instruction Trace Macrocell (ITM) whereas instructions are traced using the Embedded Trace Macrocell (ETM).

The ETM transmits information as packets and is triggered by embedded resources. These resources must be programmed independently and the trigger source is selected using the Trigger Event Register (0xE0041008). An event could be a simple event (address match from an address comparator) or a logic equation between 2 events. The trigger source is one of the fourth comparators of the DWT module, The following events can be monitored:

- clock cycle matching
- data address matching

For more informations on the trigger resources refer to [Section 30.13: DWT \(data watchpoint trigger\)](#).

The packets transmitted by the ETM are output to the TPIU (Trace Port Interface Unit). The formatter of the TPIU adds some extra packets (refer to [Section 30.17: TPIU \(trace port interface unit\)](#)) and then outputs the complete packet sequence to the debugger host.

### 30.15.2 Signal protocol, packet types

This part is described in the chapter 7 ETMv3 Signal Protocol of the ARM IHI 0014N document.

### 30.15.3 Main ETM registers

For more information on registers refer to the chapter 3 of the ARM IHI 0014N specification.

**Table 224. Main ETM registers**

Address	Register	Details
0xE0041FB0	ETM Lock Access	Write 0xC5ACCE55 to unlock the write access to the other ETM registers.
0xE0041000	ETM Control	This register controls the general operation of the ETM, for instance how tracing is enabled.
0xE0041010	ETM Status	This register provides information about the current status of the trace and trigger logic.
0xE0041008	ETM Trigger Event	This register defines the event that will control trigger.
0xE004101C	ETM Trace Enable Control	This register defines which comparator is selected.
0xE0041020	ETM Trace Enable Event	This register defines the trace enabling event.
0xE0041024	ETM Trace Start/Stop	This register defines the traces used by the trigger source to start and stop the trace, respectively.

### 30.15.4 Configuration example

To output a simple value to the TPIU:

- Configure the TPIU and enable the I/O\_TRACEN to assign TRACE IOs in the XL- and high-density device’s debug configuration register.
- Write 0xC5ACCE55 to the ETM Lock Access Register to unlock the write access to the ITM registers
- Write 0x00001D1E to the control register (configure the trace)
- Write 0000406F to the Trigger Event register (define the trigger event)
- Write 0000006F to the Trace Enable Event register (define an event to start/stop)
- Write 00000001 to the Trace Start/stop register (enable the trace)
- Write 0000191E to the ETM Control Register (end of configuration)

## 30.16 MCU debug component (DBGMCU)

The MCU debug component helps the debugger provide support for:

- Low-power modes
- Clock control for timers, watchdog, I2C and bxCAN during a breakpoint
- Control of the trace pins assignment

### 30.16.1 Debug support for low-power modes

To enter low-power mode, the instruction WFI or WFE must be executed.

The MCU implements several low-power modes which can either deactivate the CPU clock or reduce the power of the CPU.

The core does not allow FCLK or HCLK to be turned off during a debug session. As these are required for the debugger connection, during a debug, they must remain active. The MCU integrates special means to allow the user to debug software in low-power modes.

For this, the debugger host must first set some debug configuration registers to change the low-power mode behavior:

- In Sleep mode, DBG\_SLEEP bit of DBGMCU\_CR register must be previously set by the debugger. This will feed HCLK with the same clock that is provided to FCLK (system clock previously configured by the software).
- In Stop mode, the bit DBG\_STOP must be previously set by the debugger. This will enable the internal RC oscillator clock to feed FCLK and HCLK in STOP mode.

### 30.16.2 Debug support for timers, watchdog, bxCAN and I<sup>2</sup>C

During a breakpoint, it is necessary to choose how the counter of timers and watchdog should behave:

- they can continue to count inside a breakpoint. This is usually required when a PWM is controlling a motor, for example.
- they can stop to count inside a breakpoint. This is required for watchdog purposes.

For the bxCAN, the user can choose to block the update of the receive register during a breakpoint.

For the I<sup>2</sup>C, the user can choose to block the SMBUS timeout during a breakpoint.

### 30.16.3 Debug MCU configuration register

This register allows the configuration of the MCU under DEBUG. This concerns:

- Low-power mode support
- Timer and watchdog counter support
- bxCAN communication support
- Trace pin assignment

This DBGMCU\_CR is mapped on the External PPB bus at address 0xE0042004

It is asynchronously reset by the PORESET (and not the system reset). It can be written by the debugger under system reset.

If the debugger host does not support these features, it is still possible for the user software to write to these registers.

**DBGMCU\_CR**

Address: 0xE004 2004

Only 32-bit access supported

POR Reset: 0x0000 0000 (not reset by system reset)

31	30	29	28	27	26	25	24	23	22	21	20	19	18	17	16	
Res.	DBG_TIM11_STOP	DBG_TIM10_STOP	DBG_TIM9_STOP	DBG_TIM14_STOP	DBG_TIM13_STOP	DBG_TIM12_STOP	Reserved				DGB_CAN2_STOP	DBG_TIM7_STOP	DBG_TIM6_STOP	DBG_TIM5_STOP	DBG_TIM8_STOP	DBG_I2C2_SMBUS_TIMEOUT
	rw	rw	rw	rw	rw	rw					rw	rw	rw	rw	rw	rw
15	14	13	12	11	10	9	8	7	6	5	4	3	2	1	0	
DBG_I2C1_SMBUS_TIMEOUT	DBG_CAN1_STOP	DBG_TIM4_STOP	DBG_TIM3_STOP	DBG_TIM2_STOP	DBG_TIM1_STOP	DBG_WWDG_STOP	DBG_IWDG_STOP	TRACE_MODE [1:0]		TRACE_IOEN	Reserved			DBG_STANDBY	DBG_STOP	DBG_SLEEP
rw	rw	rw	rw	rw	rw	rw	rw	rw	rw	rw				rw	rw	rw

Bit 31 Reserved, must be kept cleared.

Bits 30:25 **DBG\_TIMx\_STOP**: TIMx counter stopped when core is halted (x=9..14)

0: The clock of the involved timer counter is fed even if the core is halted, and the outputs behave normally.

1: The clock of the involved timer counter is stopped when the core is halted, and the outputs are disabled (as if there were an emergency stop in response to a break event).

Bits 24:22 Reserved, must be kept cleared.

Bit 21 **DBG\_CAN2\_STOP**: Debug CAN2 stopped when core is halted

0: Same behavior as in normal mode

1: CAN2 receive registers are frozen

Bits 20:17 **DBG\_TIMx\_STOP**: TIMx counter stopped when core is halted (x=8..5)

0: The clock of the involved timer counter is fed even if the core is halted, and the outputs behave normally.

1: The clock of the involved timer counter is stopped when the core is halted, and the outputs are disabled (as if there were an emergency stop in response to a break event).

Bit 16 **DBG\_I2C2\_SMBUS\_TIMEOUT**: SMBUS timeout mode stopped when Core is halted

0: Same behavior as in normal mode

1: The SMBUS timeout is frozen

Bit 15 **DBG\_I2C1\_SMBUS\_TIMEOUT**: SMBUS timeout mode stopped when Core is halted

0: Same behavior as in normal mode

1: The SMBUS timeout is frozen

Bit 14 **DBG\_CAN1\_STOP**: Debug CAN1 stopped when Core is halted

0: Same behavior as in normal mode

1: CAN1 receive registers are frozen

Bits 13:10 **DBG\_TIMx\_STOP**: TIMx counter stopped when core is halted (x=4..1)

0: The clock of the involved Timer Counter is fed even if the core is halted

1: The clock of the involved Timer counter is stopped when the core is halted

Bit 9 **DBG\_WWDG\_STOP**: Debug window watchdog stopped when core is halted

0: The window watchdog counter clock continues even if the core is halted

1: The window watchdog counter clock is stopped when the core is halted



Bit 8 **DBG\_IWDG\_STOP**: Debug independent watchdog stopped when core is halted

- 0: The watchdog counter clock continues even if the core is halted
- 1: The watchdog counter clock is stopped when the core is halted

Bits 7:5 **TRACE\_MODE[1:0] and TRACE\_IOEN**: Trace pin assignment control

- With *TRACE\_IOEN=0*:
  - TRACE\_MODE=xx: TRACE pins not assigned (default state)
- With *TRACE\_IOEN=1*:
  - TRACE\_MODE=00: TRACE pin assignment for Asynchronous Mode
  - TRACE\_MODE=01: TRACE pin assignment for Synchronous Mode with a TRACEDATA size of 1
  - TRACE\_MODE=10: TRACE pin assignment for Synchronous Mode with a TRACEDATA size of 2
  - TRACE\_MODE=11: TRACE pin assignment for Synchronous Mode with a TRACEDATA size of 4

Bit 4:3 Reserved, must be kept cleared.

Bit 2 **DBG\_STANDBY**: Debug Standby mode

- 0: (FCLK=Off, HCLK=Off) The whole digital part is unpowered. From software point of view, exiting from Standby is identical than fetching reset vector (except a few status bit indicated that the MCU is resuming from Standby)
- 1: (FCLK=On, HCLK=On) In this case, the digital part is not unpowered and FCLK and HCLK are provided by the internal RC oscillator which remains active. In addition, the MCU generate a system reset during Standby mode so that exiting from Standby is identical than fetching from reset

Bit 1 **DBG\_STOP**: Debug Stop mode

- 0: (FCLK=Off, HCLK=Off) In STOP mode, the clock controller disables all clocks (including HCLK and FCLK). When exiting from STOP mode, the clock configuration is identical to the one after RESET (CPU clocked by the 8 MHz internal RC oscillator (HSI)). Consequently, the software must reprogram the clock controller to enable the PLL, the Xtal, etc.
- 1: (FCLK=On, HCLK=On) In this case, when entering STOP mode, FCLK and HCLK are provided by the internal RC oscillator which remains active in STOP mode. When exiting STOP mode, the software must reprogram the clock controller to enable the PLL, the Xtal, etc. (in the same way it would do in case of DBG\_STOP=0)

Bit 0 **DBG\_SLEEP**: Debug Sleep mode

- 0: (FCLK=On, HCLK=Off) In Sleep mode, FCLK is clocked by the system clock as previously configured by the software while HCLK is disabled. In Sleep mode, the clock controller configuration is not reset and remains in the previously programmed state. Consequently, when exiting from Sleep mode, the software does not need to reconfigure the clock controller.
- 1: (FCLK=On, HCLK=On) In this case, when entering Sleep mode, HCLK is fed by the same clock that is provided to FCLK (system clock as previously configured by the software).

## 30.17 TPIU (trace port interface unit)

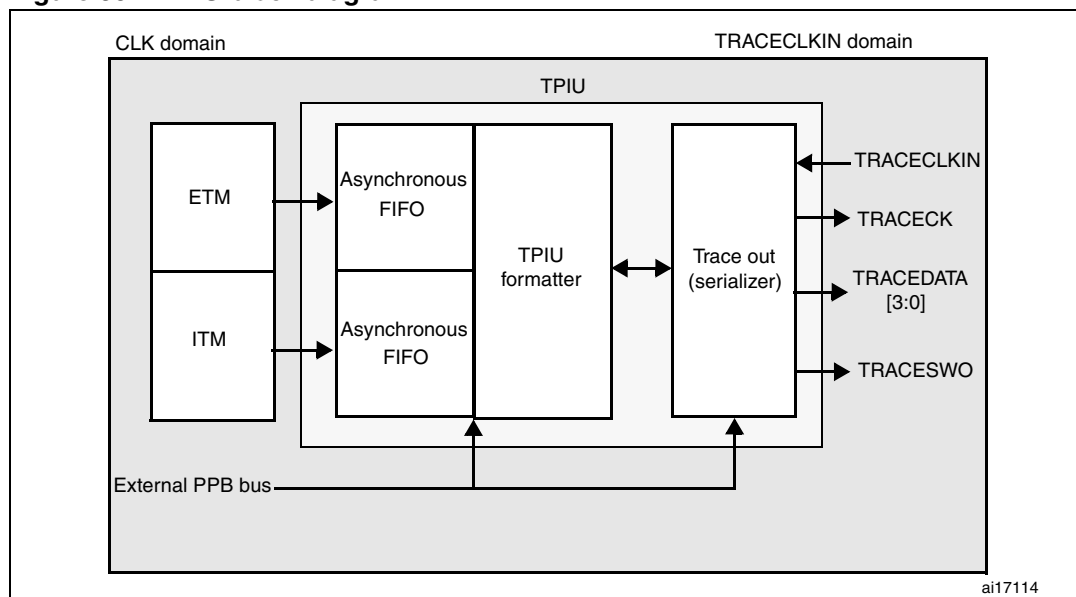
### 30.17.1 Introduction

The TPIU acts as a bridge between the on-chip trace data from the ITM and the ETM.

The output data stream encapsulates the trace source ID, that is then captured by a *trace port analyzer* (TPA).

The core embeds a simple TPIU, especially designed for low-cost debug (consisting of a special version of the CoreSight TPIU).

**Figure 364. TPIU block diagram**



### 30.17.2 TRACE pin assignment

- Asynchronous mode  
The asynchronous mode requires 1 extra pin and is available on all packages. It is only available if using Serial Wire mode (not in JTAG mode).

**Table 225. Asynchronous TRACE pin assignment**

TPUI pin name	Trace synchronous mode		STM32F10xxx pin assignment
	Type	Description	
TRACESWO	O	TRACE Async Data Output	PB3

- Synchronous mode  
The synchronous mode requires from 2 to 6 extra pins depending on the data trace size and is only available in the larger packages. In addition it is available in JTAG mode and in Serial Wire mode and provides better bandwidth output capabilities than asynchronous trace.

**Table 226. Synchronous TRACE pin assignment**

TPUI pin name	Trace synchronous mode		STM32F10xxx pin assignment
	Type	Description	
TRACECK	O	TRACE Clock	PE2
TRACED[3:0]	O	TRACE Sync Data Outputs Can be 1, 2 or 4.	PE[6:3]

### TPUI TRACE pin assignment

By default, these pins are NOT assigned. They can be assigned by setting the TRACE\_IOEN and TRACE\_MODE bits in the **MCU Debug component configuration register**. This configuration has to be done by the debugger host.

In addition, the number of pins to assign depends on the trace configuration (asynchronous or synchronous).

- **Asynchronous mode:** 1 extra pin is needed
- **Synchronous mode:** from 2 to 5 extra pins are needed depending on the size of the data trace port register (1, 2 or 4):
  - TRACECK
  - TRACED(0) if port size is configured to 1, 2 or 4
  - TRACED(1) if port size is configured to 2 or 4
  - TRACED(2) if port size is configured to 4
  - TRACED(3) if port size is configured to 4

To assign the TRACE pin, the debugger host must program the bits TRACE\_IOEN and TRACE\_MODE[1:0] of the Debug MCU configuration Register (DBGMCU\_CR). By default the TRACE pins are not assigned.

This register is mapped on the external PPB and is reset by the PORESET (and not by the SYSTEM reset). It can be written by the debugger under SYSTEM reset.

**Table 227. Flexible TRACE pin assignment**

DBGMCU_CR register		Pins assigned for:	TRACE IO pin assigned					
TRACE_IOEN	TRACE_MODE[1:0]		PB3 / JTDO / TRACESWO	PE2 / TRACECK	PE3 / TRACED[0]	PE4 / TRACED[1]	PE5 / TRACED[2]	PE6 / TRACED[3]
0	XX	No Trace (default state)	Released <sup>(1)</sup>					
1	00	Asynchronous Trace	TRACESWO			Released (usable as GPIO)		
1	01	Synchronous Trace 1 bit	Released <sup>(1)</sup>	TRACECK	TRACED[0]			
1	10	Synchronous Trace 2 bit		TRACECK	TRACED[0]	TRACED[1]		
1	11	Synchronous Trace 4 bit		TRACECK	TRACED[0]	TRACED[1]	TRACED[2]	TRACED[3]

1. When Serial Wire mode is used, it is released. But when JTAG is used, it is assigned to JTDO.

*Note:* By default, the TRACECLKIN input clock of the TPIU is tied to GND. It is assigned to HCLK two clock cycles after the bit TRACE\_IOEN has been set.

The debugger must then program the Trace Mode by writing the PROTOCOL[1:0] bits in the SPP\_R (Selected Pin Protocol) register of the TPIU.

- PROTOCOL=00: Trace Port Mode (synchronous)
- PROTOCOL=01 or 10: Serial Wire (Manchester or NRZ) Mode (asynchronous mode). Default state is 01

It then also configures the TRACE port size by writing the bits [3:0] in the CPSPS\_R (Current Sync Port Size Register) of the TPIU:

- 0x1 for 1 pin (default state)
- 0x2 for 2 pins
- 0x8 for 4 pins

### 30.17.3 TPUI formatter

The formatter protocol outputs data in 16-byte frames:

- seven bytes of data
- eight bytes of mixed-use bytes consisting of:
  - 1 bit (LSB) to indicate it is a DATA byte ('0) or an ID byte ('1).
  - 7 bits (MSB) which can be data or change of source ID trace.
- one byte of auxiliary bits where each bit corresponds to one of the eight mixed-use bytes:
  - if the corresponding byte was a data, this bit gives bit0 of the data.
  - if the corresponding byte was an ID change, this bit indicates when that ID change takes effect.

*Note:* Refer to the *ARM CoreSight Architecture Specification v1.0 (ARM IHI 0029B)* for further information

### 30.17.4 TPUI frame synchronization packets

The TPUI can generate two types of synchronization packets:

- The Frame Synchronization packet (or Full Word Synchronization packet)  
It consists of the word: 0x7F\_FF\_FF\_FF (LSB emitted first). This sequence can not occur at any other time provided that the ID source code 0x7F has not been used.  
It is output periodically **between** frames.  
In continuous mode, the TPA must discard all these frames once a synchronization frame has been found.
- The Half-Word Synchronization packet  
It consists of the half word: 0x7F\_FF (LSB emitted first).  
It is output periodically **between or within** frames.  
These packets are only generated in continuous mode and enable the TPA to detect that the TRACE port is in IDLE mode (no TRACE to be captured). When detected by the TPA, it must be discarded.

### 30.17.5 Transmission of the synchronization frame packet

There is no Synchronization Counter register implemented in the TPIU of the core. Consequently, the synchronization trigger can only be generated by the **DWT**. Refer to the registers DWT Control Register (bits SYNCTAP[11:10]) and the DWT Current PC Sampler Cycle Count Register.

The TPUI Frame synchronization packet (0x7F\_FF\_FF\_FF) is emitted:

- after each TPIU reset release. This reset is synchronously released with the rising edge of the TRACECLKIN clock. This means that this packet is transmitted when the

TRACE\_IOEN bit in the DBGMCU\_CFG register is set. In this case, the word 0x7F\_FF\_FF\_FF is not followed by any formatted packet.

- at each DWT trigger (assuming DWT has been previously configured). Two cases occur:
  - If the bit SYNENA of the ITM is reset, only the word 0x7F\_FF\_FF\_FF is emitted without any formatted stream which follows.
  - If the bit SYNENA of the ITM is set, then the ITM synchronization packets will follow (0x80\_00\_00\_00\_00\_00), formatted by the TPUI (trace source ID added).

### 30.17.6 Synchronous mode

The trace data output size can be configured to 4, 2 or 1 pin: TRACED(3:0)

The output clock is output to the debugger (TRACECK)

Here, TRACECLKIN is driven internally and is connected to HCLK only when TRACE is used.

*Note:* In this synchronous mode, it is not required to provide a stable clock frequency.

The TRACE IOs (including TRACECK) are driven by the rising edge of TRACLKIN (equal to HCLK). Consequently, the output frequency of TRACECK is equal to HCLK/2.

### 30.17.7 Asynchronous mode

This is a low cost alternative to output the trace using only 1 pin: this is the asynchronous output pin TRACESWO. Obviously there is a limited bandwidth.

TRACESWO is multiplexed with JTDO when using the SW-DP pin. This way, this functionality is available in all STM32F10xxx packages.

This asynchronous mode requires a constant frequency for TRACECLKIN. For the standard UART (NRZ) capture mechanism, 5% accuracy is needed. The Manchester encoded version is tolerant up to 10%.

### 30.17.8 TRACECLKIN connection inside the STM32F10xxx

In the STM32F10xxx, this TRACECLKIN input is internally connected to HCLK. This means that when in asynchronous trace mode, the application is restricted to use to time frames where the CPU frequency is stable.

*Note:* **Important:** when using asynchronous trace: it is important to be aware that:

*The default clock of the STM32F10xxx MCUs is the internal RC oscillator. Its frequency under reset is different from the one after reset release. This is because the RC calibration is the default one under system reset and is updated at each system reset release.*

*Consequently, the trace port analyzer (TPA) should not enable the trace (with the TRACE\_IOEN bit) under system reset, because a Synchronization Frame Packet will be issued with a different bit time than trace packets which will be transmitted after reset release.*

### 30.17.9 TPIU registers

The TPIU APB registers can be read and written only if the bit TRCENA of the Debug Exception and Monitor Control Register (DEMCR) is set. Otherwise, the registers are read as zero (the output of this bit enables the PCLK of the TPIU).

**Table 228. Important TPIU registers**

Address	Register	Description
0xE0040004	Current port size	Allows the trace port size to be selected: Bit 0: Port size = 1 Bit 1: Port size = 2 Bit 2: Port size = 3, not supported Bit 3: Port Size = 4 Only 1 bit must be set. By default, the port size is one bit. (0x00000001)
0xE00400F0	Selected pin protocol	Allows the Trace Port Protocol to be selected: Bit1:0= 00: Sync Trace Port Mode 01: Serial Wire Output - manchester (default value) 10: Serial Wire Output - NRZ 11: reserved
0xE0040304	Formatter and flush control	Bit 31-9 = always '0 Bit 8 = TrigIn = always '1 to indicate that triggers are indicated Bit 7-4 = always 0 Bit 3-2 = always 0 Bit 1 = EnFCont. In Sync Trace mode (Select_Pin_Protocol register bit1:0=00), this bit is forced to '1: the formatter is automatically enabled in continuous mode. In asynchronous mode (Select_Pin_Protocol register bit1:0 <> 00), this bit can be written to activate or not the formatter. Bit 0 = always 0 The resulting default value is 0x102 <b>Note:</b> In synchronous mode, because the TRACECTL pin is not mapped outside the chip, the formatter is always enabled in continuous mode -this way the formatter inserts some control packets to identify the source of the trace packets).
0xE0040300	Formatter and flush status	Not used in Cortex-M3, always read as 0x00000008

**30.17.10 Example of configuration**

- Set the bit TRCENA in the Debug Exception and Monitor Control Register (DEMCR)
- Write the TPIU Current Port Size Register to the desired value (default is 0x1 for a 1-bit port size)
- Write TPIU Formatter and Flush Control Register to 0x102 (default value)
- Write the TPIU Select Pin Protocol to select the sync or async mode. Example: 0x2 for async NRZ mode (UART like)
- Write the DBGMCU control register to 0x20 (bit IO\_TRACEN) to assign TRACE IOs for async mode. A TPIU Sync packet is emitted at this time (FF\_FF\_FF\_7F)
- Configure the ITM and write the ITM Stimulus register to output a value

### 30.18 DBG register map

The following table summarizes the Debug registers.

**Table 229. DBG register map and reset values**

Addr.	Register	31	30	29	28	27	26	25	24	23	22	21	20	19	18	17	16	15	14	13	12	11	10	9	8	7	6	5	4	3	2	1	0				
0xE0042000	DBGMCU_IDCODE	REV_ID														Reserved				DEV_ID																	
	Reset value <sup>(1)</sup>	X	X	X	X	X	X	X	X	X	X	X	X	X	X	X	X					X	X	X	X	X	X	X	X	X	X	X	X				
0xE0042004	DBGMCU_CR	Reserved														DBG_CAN2_STOP	DBG_TIM7_STOP	DBG_TIM6_STOP	DBG_TIM5_STOP	DBG_TIM8_STOP	DBG_I2C2_SMBUS_TIMEOUT	DBG_I2C1_SMBUS_TIMEOUT	DBG_CAN1_STOP	DBG_TIM4_STOP	DBG_TIM3_STOP	DBG_TIM2_STOP	DBG_TIM1_STOP	DBG_WWDG_STOP	DBG_IWDG_STOP	TRACE_MODE[1:0]		TRACE_IOEN	Reserved		DBG_STANDBY	DBG_STOP	DBG_SLEEP
	Reset value																0	0	0	0	0	0	0	0	0	0	0	0	0			0	0	0			

1. The reset value is product dependent. For more information, refer to [Section 30.6.1: MCU device ID code](#).

## 31 Revision history

**Table 230. Document revision history**

Date	Revision	Changes
19-Oct-2007	1	<p>Document reference number changed from UM0306 to RM008. The changes below were made with reference to revision 1 of 01-Jun-2007 of UM0306.</p> <p>EXTSEL[2:0] and JEXTSEL[2:0] removed from <a href="#">Table 68: ADC pins on page 217</a> and <math>V_{REF+}</math> range modified in Remarks column.</p> <p>Notes added to <a href="#">Section 11.3.9 on page 220</a>, <a href="#">Section 11.9.2 on page 228</a>, <a href="#">Section 11.9.7 on page 231</a> and <a href="#">Section 11.9.9 on page 232</a>.</p> <p>SPI_CR2 corrected to SPI_CR1 in <a href="#">1 clock and 1 bidirectional data wire (BIDIMODE=1) on page 662</a>.</p> <p><math>f_{CPU}</math> frequency changed to <math>f_{PCLK}</math> in <a href="#">Section 24.2: SPI and I2S main features on page 655</a>, <a href="#">Section 24.3.6: CRC calculation on page 669</a> and <a href="#">Section 24.3.9: SPI communication using DMA (direct memory addressing) on page 672</a> modified.</p> <p>Note added to bit 13 description changed in <a href="#">Section 24.5.1: SPI control register 1 (SPI_CR1) (not used in I2S mode) on page 693</a>. Note for bit 4 modified in <a href="#">Section 24.5.3: SPI status register (SPI_SR) on page 695</a>.</p> <p><a href="#">On 64-pin packages and packages with less pins on page 60</a> modified.</p> <p><a href="#">Section 8.3.2: Using OSC_IN/OSC_OUT pins as GPIO ports PD0/PD1 on page 161</a> updated.</p> <p>Description of SRAM at address 0x4000 6000 modified in <a href="#">Figure 2: Memory map on page 39</a> and <a href="#">Table 1: Register boundary addresses</a>.</p> <p>Note added to <a href="#">Section 22.2: USB main features on page 580</a> and <a href="#">Section 23.2: bxCAN main features on page 610</a>.</p> <p><a href="#">Figure 4: Power supply overview</a> and <a href="#">On 100-pin and 144-pin packages</a> modified.</p> <p>Formula added to Bits 25:24 description in <a href="#">CAN bit timing register (CAN_BTR) on page 639</a>.</p> <p><a href="#">Section 10.3: DMA functional description on page 199</a> modified.</p> <p><a href="#">Example of configuration on page 1045</a> modified.</p> <p>MODEx[1:0] bit definitions corrected in <a href="#">Section 8.2.2: Port configuration register high (GPIOx_CRH) (x=A..G) on page 158</a>.</p> <p><a href="#">Downcounting mode on page 276</a> modified.</p> <p><a href="#">Figure 81: Output stage of capture/compare channel (channel 4) on page 287</a> and <a href="#">Figure 83: Output compare mode, toggle on OC1</a>. modified. OCx output enable conditions modified in <a href="#">Section 13.3.10: PWM mode on page 291</a>.</p> <p><a href="#">Section 13.3.19: TIMx and external trigger synchronization on page 306</a> title changed.</p> <p>CC1S, CC2S, CC3S and CC4S definitions modified for (1, 1) bit setting modified in <a href="#">Section 13.4.7: TIM1&amp;TIM8 capture/compare mode register 1 (TIMx_CCMR1)</a> and <a href="#">Section 13.4.8: TIM1&amp;TIM8 capture/compare mode register 2 (TIMx_CCMR2)</a>.</p> <p>CC1S, CC2S, CC3S and CC4S definitions for (1, 1) bit setting modified in <a href="#">Section 14.4.7: TIMx capture/compare mode register 1 (TIMx_CCMR1)</a> and <a href="#">Section 14.4.8: Capture/compare mode register 2 (TIMx_CCMR2)</a>.</p> <p>AFIO_EVCR pins modified in <a href="#">Table 58: AFIO register map and reset values on page 179</a>.</p> <p><a href="#">Section 13.3.6: Input capture mode on page 287</a> modified.</p>



Table 230. Document revision history (continued)

Date	Revision	Changes
19-Oct-2007 continued	1 continued	<p><a href="#">Figure 114: Counter timing diagram, internal clock divided by 1, TIMx_ARR=0x6</a> and <a href="#">Figure 129: Output compare mode, toggle on OC1</a>. modified. CKD definition modified in <a href="#">Section 14.4.1: TIMx control register 1 (TIMx_CR1)</a>.</p> <p>Bit 8 and Bit 9 added to <a href="#">Section 5.4.2: RTC clock calibration register (BKP_RTCCR)</a>. Bit 15 and Bit 16 added to <a href="#">DBGMCU_CR on page 1048</a>. <a href="#">Section 25.5: I2C debug mode on page 722</a> added.</p> <p>Stop and Standby modified in <a href="#">Table 9: Low-power mode summary</a>. <a href="#">Table 11: Sleep-on-exit</a> modified. <a href="#">Debug mode on page 69</a> modified.</p> <p>HSITRIM[4:0] bit description modified in <a href="#">Section 6.3.1: Clock control register (RCC_CR)</a>. Note modified in MCO description in <a href="#">Section 6.3.2: Clock configuration register (RCC_CFGR)</a>. RCC_CR row modified in <a href="#">RCC register map and reset values on page 111</a>.</p> <p>Bits 15:0 description modified in <a href="#">Section 8.2.6: Port bit reset register (GPIOx_BRR) (x=A..G)</a>. <a href="#">Embedded boot loader on page 55</a> added.</p> <p><a href="#">Figure 13</a>, <a href="#">Figure 15</a>, <a href="#">Figure 16</a>, <a href="#">Figure 17</a> and <a href="#">Figure 18</a> modified. <a href="#">Section 2.3.3: Embedded Flash memory on page 48</a> modified.</p> <p>REV_ID bit description added to <a href="#">DBGMCU_IDCODE on page 1034</a>.</p> <p>Reset value modified in <a href="#">Clock control register (RCC_CR) on page 90</a> and HSITRIM[4:0] description modified.</p> <p><a href="#">Section 8.1.1 on page 148</a> modified. Bit definitions modified in <a href="#">Section 8.2: GPIO registers on page 157</a>. Wakeup latency description modified in <a href="#">Table 12: Stop mode</a>. <a href="#">Clock control register (RCC_CR)</a> reset value modified.</p> <p>Note added in ASOS and ASOE bit descriptions in <a href="#">5.4.2 on page 75</a>.</p> <p><a href="#">Section 30.16.2: Debug support for timers, watchdog, bxCAN and I2C</a> modified. <a href="#">Table 229: DBG register map and reset values</a> updated.</p> <p><a href="#">Section 22.5.3: Buffer descriptor table</a> clarified.</p> <p><a href="#">Center-aligned mode (up/down counting) on page 278</a> and <a href="#">Center-aligned mode (up/down counting) on page 344</a> updated.</p> <p><a href="#">Figure 85: Center-aligned PWM waveforms (ARR=8) on page 293</a> and <a href="#">Figure 131: Center-aligned PWM waveforms (ARR=8) on page 357</a> modified.</p> <p>RSTCAL description modified in <a href="#">Section 11.12.3: ADC control register 2 (ADC_CR2)</a>. Note changed below <a href="#">Table 94: Min/max IWDG timeout period at 40 kHz (LSI)</a>. Note added below <a href="#">Figure 8: Clock tree</a>.</p> <p>ADC conversion time modified in <a href="#">Section 11.2: ADC main features</a>. <a href="#">Auto-injection on page 220</a> updated.</p> <p>Note added in <a href="#">Section 11.9.9: Combined injected simultaneous + interleaved</a>. Note added to <a href="#">Section 8.3.2: Using OSC_IN/OSC_OUT pins as GPIO ports PD0/PD1</a>. Small text changes. Internal LSI RC frequency changed from 32 to 40 kHz. <a href="#">Table 94: Min/max IWDG timeout period at 40 kHz (LSI)</a> updated. Option byte addresses corrected in <a href="#">Figure 2: Memory map</a> and <a href="#">Table 3: Flash module organization (medium-density devices)</a>.</p> <p>Information block organization modified in <a href="#">Section 2.3.3: Embedded Flash memory</a>.</p> <p>External event that trigger ADC conversion is EXTI line instead of external interrupt (see <a href="#">Section 11: Analog-to-digital converter (ADC)</a>).</p> <p><a href="#">Appendix A: Important notes on page 500</a> added.</p>

Table 230. Document revision history (continued)

Date	Revision	Changes
20-Nov-2007	2	<p><a href="#">Figure 278: USART block diagram</a> modified.</p> <p>Procedure modified in <a href="#">Character reception on page 743</a>.</p> <p>In <a href="#">Section 26.3.4: Fractional baud rate generation</a>:</p> <ul style="list-style-type: none"> <li>– Equation legend modified</li> <li>– <a href="#">Table 189: Error calculation for programmed baud rates</a> modified</li> <li>– Note added</li> </ul> <p>Small text changes. In <a href="#">CAN bit timing register (CAN_BTR) on page 639</a>, bit 15 is reserved.</p> <p>Flash memory organization corrected, <a href="#">Table 3: Flash module organization (medium-density devices)</a> modified in <a href="#">Section 2.3.3: Embedded Flash memory</a>.</p> <p>Note added below <a href="#">Figure 4: Power supply overview</a> in <a href="#">Section 4.1: Power supplies</a>.</p> <p>RTCSEL[1:0] bit description modified in <a href="#">Backup domain control register (RCC_BDCR)</a>.</p> <p>Names of bits [0:2] corrected for RCC_APB1RSTR and RCC_APB1ENR in <a href="#">Table 16: RCC register map and reset values</a>.</p> <p>Impedance value specified in <a href="#">A.4: Voltage glitch on ADC input 0 on page 500</a>.</p> <p>In <a href="#">Section 24.5.1: SPI control register 1 (SPI_CR1) (not used in I2S mode)</a>, BR[2:0] description corrected.</p> <p>Prescaler buffer behavior specified when an update event occurs (see <a href="#">Upcounting mode on page 339</a>, <a href="#">Downcounting mode on page 342</a> and <a href="#">Center-aligned mode (up/down counting)</a>).</p> <p>AWDCH[4:0] modified in <a href="#">Section 11.12.2: ADC control register 1 (ADC_CR1)</a> and bits [26:24] are reserved in <a href="#">Section 11.12.4: ADC sample time register 1 (ADC_SMPR1)</a>.</p> <p>CAN_BTR bit 8 is reserved in <a href="#">Table 178: bxCAN register map and reset values. CAN master control register (CAN_MCR) on page 630</a> corrected.</p> <p>V<sub>REF+</sub> range corrected in <a href="#">Table 68: ADC pins</a> and in <a href="#">On 100-pin and 144-pin packages on page 60</a>.</p> <p><a href="#">Start condition on page 708</a> updated. Note removed in <a href="#">Table 32: CAN1 alternate function remapping</a>. Note added in <a href="#">Table 41: TIM4 alternate function remapping</a>.</p> <p>In <a href="#">Section 8.4.2: AF remap and debug I/O configuration register (AFIO_MAPR)</a>, bit definition modified for USART2_REMAP = 0. In <a href="#">Section 8.4.3: External interrupt configuration register 1 (AFIO_EXTICR1)</a>, bit definition modified for SPI1_REMAP = 0. In <a href="#">Table 228: Important TPIU registers</a>, at 0xE0040004, bit2 set is not supported.</p> <p>TRACE port size setting corrected in <a href="#">TPUI TRACE pin assignment on page 1051</a>.</p> <p><a href="#">Figure 13</a>, <a href="#">Figure 15</a>, <a href="#">Figure 16</a>, <a href="#">Figure 17</a> and <a href="#">Figure 18</a> modified. <a href="#">Figure 14: Basic structure of a five-volt tolerant I/O port bit</a> added.</p> <p><a href="#">Table 8.3.1: Using OSC32_IN/OSC32_OUT pins as GPIO ports PC14/PC15 on page 161</a> added.</p> <p>Bit descriptions modified in <a href="#">Section 17.4.5</a> and <a href="#">Section 17.4.6</a>.</p> <p>JTAG ID code corrected in <a href="#">Section 30.6.2: Boundary scan TAP on page 1035</a>.</p> <p>Modified: <a href="#">Section 19.2: WWDG main features</a>, <a href="#">Section 5.2: BKP main features</a>, <a href="#">Section 5.3.1: Tamper detection</a>, <a href="#">Section 5.3.2: RTC calibration</a>, <a href="#">Section 22.3: USB functional description, Controlling the downcounter</a>., <a href="#">Section 4.1.2: Battery backup domain</a>, <a href="#">Section 8.2: Introduction</a>.</p> <p>ASOE bit description modified in <a href="#">Section 5.4.2: RTC clock calibration register (BKP_RTCCR)</a>.</p>

Table 230. Document revision history (continued)

Date	Revision	Changes
08-Feb-2008	3	<p><a href="#">Figure 4: Power supply overview on page 60</a> modified.</p> <p><a href="#">Section 6.1.2: Power reset on page 82</a> modified.</p> <p><a href="#">Section 6.2: Clocks on page 83</a> modified.</p> <p>Definition of Bits 26:24 modified in <a href="#">Section 8.4.2: AF remap and debug I/O configuration register (AFIO_MAPR) on page 170</a>.</p> <p>AFIO_EVCR bits corrected in <a href="#">Table 58: AFIO register map and reset values on page 179</a>.</p> <p>Number of maskable interrupt channels modified in <a href="#">Section 9.1: Nested vectored interrupt controller (NVIC) on page 181</a>.</p> <p><a href="#">Section 10.3.6: Interrupts on page 203</a> added. Small text changes.</p> <p>Examples modified in <a href="#">Figure 91: 6-step generation, COM example (OSSR=1) on page 299</a>.</p> <p><a href="#">Table 81: Output control bits for complementary OCx and OCxN channels with break feature on page 326</a> modified.</p> <p>Register names modified in <a href="#">Section 23.9.4: CAN filter registers on page 647</a>.</p> <p>Small text change in <a href="#">Section 25.3.3: I2C master mode on page 707</a>.</p> <p>Bits 5:0 frequency description modified in <a href="#">Section 25.6.2: Control register 2 (I2C_CR2) on page 724</a>.</p> <p><a href="#">Section 22.3.1: Description of USB blocks on page 582</a> modified.</p> <p><a href="#">Section 24.3.4: Configuring the SPI for Simplex communication on page 662</a> modified.</p> <p><a href="#">Section 24.3.6: CRC calculation on page 669</a> modified.</p> <p>Note added in <a href="#">BUSY flag on page 671</a>.</p> <p><a href="#">Section 24.3.8: Disabling the SPI on page 671</a> added.</p> <p>Appendix A: Important notes, removed.</p>
22-May-2008	4 continued on next page	<p>Reference manual updated to apply to devices containing up to 512 Kbytes of Flash memory (High-density devices). Document restructured. Small text changes. Definitions of Medium-density and High-density devices added to all sections.</p> <p>In <a href="#">Section 2: Memory and bus architecture on page 41</a>:</p> <ul style="list-style-type: none"> <li>– <a href="#">Figure 1: System architecture on page 41</a>, <a href="#">Figure 2: Memory map on page 39</a>, <a href="#">Table 1: Register boundary addresses on page 44</a> updated</li> <li>– Note and text added to <a href="#">AHB/APB bridges (APB) on page 43</a></li> <li>– SRAM size in <a href="#">Section 2.3.1: Embedded SRAM on page 47</a></li> <li>– <a href="#">Section 2.3.3: Embedded Flash memory on page 48</a> updated (Flash size, page size, number of pages, <a href="#">Reading the Flash memory</a>, <a href="#">Table 4: Flash module organization (high-density devices) on page 50</a> added)</li> <li>– Prefetch buffer on/off specified in <a href="#">Reading the Flash memory</a></li> </ul> <p><a href="#">bit_number</a> definition modified in <a href="#">Section 2.3.2: Bit banding on page 47</a>.</p> <p><a href="#">Section 3: CRC calculation unit on page 56</a> added (<a href="#">Table 1: Register boundary addresses on page 44</a> updated, <a href="#">Figure 2: Memory map on page 39</a> updated and CRCEN bit added to <a href="#">Section 6.3.6: AHB peripheral clock enable register (RCC_AHBENR) on page 102</a>).</p> <p><a href="#">Entering Stop mode on page 66</a> specified.</p> <p>Updated in <a href="#">Section 5: Backup registers (BKP) on page 73</a>: number of backup registers and available storage size and <a href="#">Section 5.1: BKP introduction</a>. ASOE definition modified in <a href="#">Section 5.4.2: RTC clock calibration register (BKP_RTCCR) on page 75</a>.</p>

Table 230. Document revision history (continued)

Date	Revision	Changes
22-May-2008 continued	4 continued	<p>In <a href="#">Section 6: Low-, medium-, high- and XL-density reset and clock control (RCC) on page 81</a>:</p> <ul style="list-style-type: none"> <li>– <a href="#">LSI calibration on page 87</a> added</li> <li>– <a href="#">Figure 7: Simplified diagram of the reset circuit on page 82</a> updated</li> <li>– <a href="#">APB2 peripheral reset register (RCC_APB2RSTR) on page 97</a> updated</li> <li>– <a href="#">APB1 peripheral reset register (RCC_APB1RSTR) on page 99</a> updated</li> <li>– <a href="#">AHB peripheral clock enable register (RCC_AHBENR)</a> updated</li> <li>– <a href="#">APB2 peripheral clock enable register (RCC_APB2ENR)</a> updated</li> <li>– <a href="#">APB1 peripheral clock enable register (RCC_APB1ENR) on page 105</a> updated (see <a href="#">Section Table 16.: RCC register map and reset values</a>).</li> <li>– LSE RDYIE definition modified in <a href="#">Clock interrupt register (RCC_CIR)</a></li> <li>– HSITRIM[4:0] definition modified in <a href="#">Clock control register (RCC_CR)</a></li> </ul> <p>In <a href="#">Section 8: General-purpose and alternate-function I/Os (GPIOs and AFIOs) on page 146</a>:</p> <ul style="list-style-type: none"> <li>– GPIO ports F and G added</li> <li>– In <a href="#">Section 8.3: Alternate function I/O and debug configuration (AFIO) on page 161</a> remapping for High-density devices added, note modified under <a href="#">Section 8.3.2, Section 8.3.3 on page 162</a> modified</li> <li>– <a href="#">AF remap and debug I/O configuration register (AFIO_MAPR)</a> updated</li> </ul> <p>Updated in <a href="#">Section 9: Interrupts and events on page 181</a>:</p> <ul style="list-style-type: none"> <li>– number of maskable interrupt channels</li> <li>– number of GPIOs (see <a href="#">Figure 21: External interrupt/event GPIO mapping</a>)</li> </ul> <p>In <a href="#">Section 10: DMA controller (DMA) on page 197</a>:</p> <ul style="list-style-type: none"> <li>– number of DMA controllers and configurable DMA channels updated</li> <li>– <a href="#">Figure 22: DMA block diagram in connectivity line devices on page 198</a> updated, notes added</li> <li>– Note updated in <a href="#">Section 10.3.2: Arbiter on page 200</a></li> <li>– Note updated in <a href="#">Section 10.3.6: Interrupts on page 203</a></li> <li>– <a href="#">Figure 24: DMA1 request mapping on page 204</a> updated</li> <li>– <a href="#">DMA2 controller on page 205</a> added</li> </ul> <p>In <a href="#">Section 11: Analog-to-digital converter (ADC) on page 214</a>:</p> <ul style="list-style-type: none"> <li>– ADC3 added (<a href="#">Figure 26: Single ADC block diagram on page 216</a> updated, <a href="#">Table 73: External trigger for injected channels for ADC3</a> added, etc.)</li> </ul> <p><a href="#">Section 12: Digital-to-analog converter (DAC) on page 249</a> added.</p> <p>In <a href="#">Section 13: Advanced-control timers (TIM1&amp;TIM8) on page 269</a>:</p> <ul style="list-style-type: none"> <li>– Advanced control timer TIM8 added (see <a href="#">Figure 52: Advanced-control timer block diagram on page 271</a>)</li> <li>– TS[2:0] modified in <a href="#">Section 13.4.3: TIM1&amp;TIM8 slave mode control register (TIMx_SMCR) on page 313</a>.</li> </ul> <p>In <a href="#">Section 14: General-purpose timer (TIM2 to TIM5) on page 335</a>:</p> <ul style="list-style-type: none"> <li>– TIM5 added</li> <li>– <a href="#">Figure 100: General-purpose timer block diagram</a> updated. <a href="#">Table 84: TIMx Internal trigger connection on page 375</a> modified. <a href="#">Section 16: Basic timers (TIM6&amp;TIM7)</a> added.</li> </ul> <p>RTC clock sources specified in <a href="#">Section 17.2: RTC main features on page 448</a>. <a href="#">Section 17.1: RTC introduction</a> modified.</p> <p><a href="#">Section 20: Flexible static memory controller (FSMC) on page 469</a> added.</p> <p><a href="#">Section 21: Secure digital input/output interface (SDIO) on page 524</a> added.</p>

Table 230. Document revision history (continued)

Date	Revision	Changes
22-May-2008 continued	4 continued	<p><a href="#">Figure 234: CAN frames on page 628</a> modified. Bits 31:21 and bits 20:3 modified in <a href="#">CAN TX mailbox identifier register (CAN_TlRxR) (x=0..2) on page 641</a>. Bits 31:21 and bits 20:3 modified in <a href="#">CAN receive FIFO mailbox identifier register (CAN_RlRxR) (x=0..1) on page 644</a>.</p> <p><a href="#">Section 25.3.7: DMA requests on page 718</a> modified. DMAEN bit 11 description modified in <a href="#">Section 25.6.2: Control register 2 (I2C_CR2) on page 724</a>.</p> <p><a href="#">Clock phase and clock polarity on page 659</a> modified. <a href="#">Transmit sequence on page 661</a> modified. <a href="#">Receive sequence on page 662</a> added. <a href="#">Reception sequence on page 690</a> modified. <a href="#">Underrun flag (UDR) on page 692</a> modified.</p> <p>I<sup>2</sup>S feature added (see <a href="#">Section 24: Serial peripheral interface (SPI) on page 654</a>).</p> <p>In <a href="#">Section 30: Debug support (DBG) on page 1027</a>:</p> <ul style="list-style-type: none"> <li>– <a href="#">DBGMCU_IDCODE on page 1034</a> and <a href="#">DBGMCU_CR on page 1048</a> updated</li> <li>– TMC TAP changed to boundary scan TAP</li> <li>– Address onto which DBGMCU_CR is mapped modified in <a href="#">Section 30.16.3: Debug MCU configuration register on page 1047</a>.</li> </ul> <p><a href="#">Section 29: Device electronic signature on page 1024</a> added.</p> <p>REV_ID(15:0) definition modified in <a href="#">Section 30.6.1: MCU device ID code on page 1033</a>.</p>
28-Jul-2008	5	<p>Developed polynomial form updated in <a href="#">Section 3.2: CRC main features on page 56</a>.</p> <p><a href="#">Figure 4: Power supply overview on page 60</a> modified.</p> <p><a href="#">Section 4.1.2: Battery backup domain on page 61</a> modified.</p> <p><a href="#">Section 6.2.5: LSI clock on page 87</a> specified.</p> <p><a href="#">Section 8.1.4: Alternate functions (AF) on page 149</a> clarified.</p> <p>Note added to <a href="#">Table 43: TIM2 alternate function remapping on page 165</a>.</p> <p>Bits are write-only in <a href="#">Section 10.4.2: DMA interrupt flag clear register (DMA_IFCR) on page 208</a>.</p> <p>Register name modified in <a href="#">Section 11.3.1: ADC on-off control on page 217</a>.</p> <p>Recommended sampling time given in <a href="#">Section 11.10: Temperature sensor on page 233</a>.</p> <p>Bit attributes modified in <a href="#">Section 11.12.1: ADC status register (ADC_SR) on page 235</a>.</p> <p>Note modified for bits 23:0 in <a href="#">Section 11.12.4: ADC sample time register 1 (ADC_SMPR1) on page 241</a>.</p> <p>Note added in <a href="#">Section 12.2: DAC main features on page 249</a>.</p> <p>Formula updated in <a href="#">Section 12.3.5: DAC output voltage on page 253</a>.</p> <p><b>DBL[4:0]</b> description modified in <a href="#">Section 13.3.19: TIMx and external trigger synchronization on page 306</a>.</p> <p><a href="#">Figure 82 on page 289</a> and <a href="#">Figure 128 on page 353</a> modified.</p> <p><a href="#">Section 24.5.3: SPI status register (SPI_SR) on page 695</a> modified.</p> <p><a href="#">Closing the communication on page 710</a> updated.</p> <p>Notes added to <a href="#">Section 25.6.8: Clock control register (I2C_CCR) on page 731</a>. TCK replaced by T<sub>PCLK1</sub> in <a href="#">Section 25.6.8</a> and <a href="#">Section 25.6.9</a>.</p> <p>OVR changed to ORE in <a href="#">Figure 301: USART interrupt mapping diagram on page 765</a>.</p> <p><a href="#">Section 26.6.1: Status register (USART_SR) on page 766</a> updated.</p> <p><a href="#">Slave select (NSS) pin management on page 658</a> clarified.</p> <p>Small text changes.</p>

Table 230. Document revision history (continued)

Date	Revision	Changes
26-Sep-2008	6	<p>This reference manual also applies to low-density STM32F101xx, STM32F102xx and STM32F103xx devices, and to medium-density STM32F102xx devices. In all sections, definitions of low-density and medium-density devices updated.</p> <p><i>Section 1.3: Peripheral availability on page 40</i> added.</p> <p><i>Section 2.3.3: Embedded Flash memory on page 48</i> updated. <i>Section 4.1.2: Battery backup domain on page 61</i> modified. Reset value of <i>Port input data register (GPIOx_IDR) (x=A..G) on page 158</i> modified. Note added in <i>Section 8.4: AFIO registers on page 168</i>. Note removed from bits 18:0 description in <i>Section 9.3.6: Pending register (EXTI_PR) on page 195</i>.</p> <p><i>Section 13.2: TIM1&amp;TIM8 main features on page 270</i> and <i>Section 14.2: TIMx main features on page 336</i> updated. In <i>Section 14.3.15: Timer synchronization on page 365</i>, TS=000.</p> <p>FSMC_CLK signal direction corrected in <i>Figure 185: FSMC block diagram on page 471</i>. "Feedback clock" paragraph removed from <i>Section 20.5.3: General timing rules on page 479</i>.</p> <p>In <i>Section 20.5.6: NOR/PSRAM controller registers on page 502</i>: reset value modified, WAITEN bit default value after reset is 1, bits [5:6] definition modified, , FACEN default value after reset specified. NWE signal behavior corrected in <i>Figure 203: Synchronous multiplexed write mode - PSRAM (CRAM) on page 500</i>. The FSMC interface does not support COSMO RAM and OneNAND devices, and it does not support the asynchronous wait feature. SRAM and ROM 32 memory data size removed from <i>Table 105: NOR Flash/PSRAM supported memories and transactions on page 478</i>.</p> <p><i>Data latency versus NOR Flash latency on page 496</i> modified. Bits 19:16 bits are reserved in <i>SRAM/NOR-Flash write timing registers 1..4 (FSMC_BWTR1..4) on page 506</i>.</p> <p><i>Section 20.6.3: Timing diagrams for NAND and PC Card on page 510</i> modified. Definition of PWID bits modified in <i>Section 20.6.8: NAND Flash/PC Card controller registers on page 516</i>. <i>Section 20.6.6: Error correction code computation ECC (NAND Flash) on page 513</i> modified.</p> <p>Interrupt Mapper definition modified in <i>Section 22.3.1: Description of USB blocks on page 582</i>. USB register and memory base addresses modified in <i>Section 22.5: USB registers on page 594</i>.</p> <p><i>Section 25.3.8: Packet error checking on page 719</i> modified.</p> <p><i>Section : Start bit detection on page 743</i> added. PE bit description specified in <i>Status register (USART_SR) on page 766</i>.</p> <p>"RAM size register" section removed from <i>Section 29: Device electronic signature on page 1024</i>. Bit definitions updated in <i>FIFO status and interrupt register 2..4 (FSMC_SR2..4) on page 517</i>.</p> <p>Small text changes.</p>

**Table 230. Document revision history (continued)**

Date	Revision	Changes
23-Dec-2008	7	<p>Memory map figure removed from reference manual. <i>Section 2.1: System architecture on page 41</i> modified. <i>Section 2.4: Boot configuration on page 54</i> modified. <i>Exiting Sleep mode on page 65</i> modified. <i>Section 5.3.2: RTC calibration on page 74</i> updated. <i>Wakeup event management on page 190</i> updated.</p> <p><i>Section 6.3: RCC registers on page 89</i> updated. <i>Section 10.2: DMA main features on page 197</i> updated.</p> <p><i>Section 10.3.5: Error management</i> modified. <i>Figure 22: DMA block diagram in connectivity line devices on page 198</i> modified. <i>Section 10.3.4: Programmable data width, data alignment and endians on page 202</i> added.</p> <p>Bit definition modified in <i>Section 10.4.5: DMA channel x peripheral address register (DMA_CPARx) (x = 1..7), where x = channel number</i> on page 211 and <i>Section 10.4.6: DMA channel x memory address register (DMA_CMARx) (x = 1..7), where x = channel number</i> on page 211.</p> <p>Note added below <i>Figure 82: PWM input mode timing</i> and <i>Figure 128: PWM input mode timing</i>.</p> <p>FSMC_NWAIT signal direction corrected in <i>Figure 185: FSMC block diagram on page 471</i>.</p> <p>Value to set modified for bit 6 in <i>Table 111: FSMC_BCRx bit fields</i>, <i>Table 114: FSMC_BCRx bit fields</i> and <i>Table 120: FSMC_BCRx bit fields</i>. <i>Table 127: 8-bit NAND Flash</i>, <i>Table 128: 16-bit NAND Flash</i> and <i>Table 129: 16-bit PC Card</i> modified. NWAIT and INTR signals separated in <i>Table 129: 16-bit PC Card</i>. Note added in PWAITEN bit definition in <i>PC Card/NAND Flash control registers 2..4 (FSMC_PCR2..4) on page 516</i>. Bit definitions updated in <i>FIFO status and interrupt register 2..4 (FSMC_SR2..4) on page 517</i>. Note modified in ADDHLD and ADDSET bit definitions in <i>SRAM/NOR-Flash chip-select timing registers 1..4 (FSMC_BTR1..4) on page 504</i>. Bit 8 is reserved in <i>PC Card/NAND Flash control registers 2..4 (FSMC_PCR2..4) on page 516</i>.</p> <p>MEMWAIT[15:8] bit definition modified in <i>Common memory space timing register 2..4 (FSMC_PMEM2..4) on page 518</i>.</p> <p>ATTWAIT[15:8] bit definition modified in <i>Attribute memory space timing registers 2..4 (FSMC_PATT2..4) on page 519</i>.</p> <p><i>Section 20.6.5: NAND Flash pre-wait functionality on page 512</i> modified. <i>Figure 204: NAND/PC Card controller timing for common memory access</i> modified.</p> <p>Note added below <i>Table 97: NOR/PSRAM bank selection on page 473</i>.</p> <p>32-bit external memory access removed from <i>Table 98: External memory address on page 474</i> and note added.</p> <p><b>Caution:</b> added to <i>Section 20.6.1: External memory interface signals</i>.</p> <p>NIOS16 description modified in <i>Table 129: 16-bit PC Card on page 509</i>.</p> <p>Register description modified in <i>Attribute memory space timing registers 2..4 (FSMC_PATT2..4) on page 519</i>.</p> <p><i>Resetting the password on page 546</i> step 2 corrected.</p> <p>write_data signal modified in <i>Figure 204: NAND/PC Card controller timing for common memory access</i>.</p> <p><i>bxCAN main features on page 610</i> modified.</p> <p><i>Section 25.3.8: Packet error checking on page 719</i> modified.</p> <p><i>Section 30.6.3: Cortex-M3 TAP</i> modified.</p> <p>DBG_TIMx_STOP positions modified in <i>DBGMCU_CR on page 1048</i>.</p> <p>Small text changes.</p>

Table 230. Document revision history (continued)

Date	Revision	Changes
11-Feb-2009	8	<p>Reset value corrected in <a href="#">Section 3.4.1: Data register (CRC_DR)</a>.</p> <p><a href="#">Section 11.10: Temperature sensor</a> modified. Reset value corrected in <a href="#">Section 11.12.7: ADC watchdog high threshold register (ADC_HTR)</a>.</p> <p><a href="#">Section 12.3.9: Triangle-wave generation</a> and <a href="#">Figure 50: DAC triangle wave generation</a> updated.</p> <p><a href="#">Section 23.6: STM32F10xxx in Debug mode</a> added. Bit 16 updated in <a href="#">CAN master control register (CAN_MCR)</a> on page 630.</p> <p>Note added to <a href="#">Section 24.3.6: CRC calculation</a>.</p> <p>Changes concerning the I<sup>2</sup>C peripheral (<a href="#">Inter-integrated circuit (I2C) interface</a>):</p> <ul style="list-style-type: none"> <li>– In <a href="#">Slave transmitter on page 706</a>: text changes and <a href="#">Figure 270: Transfer sequence diagram for slave transmitter</a> modified.</li> <li>– In <a href="#">Slave receiver on page 707</a>: text changes and <a href="#">Figure 271: Transfer sequence diagram for slave receiver</a> modified.</li> <li>– <a href="#">Master transmitter on page 709</a> and <a href="#">Master receiver on page 710</a> clarified.</li> <li>– In <a href="#">Closing the communication on page 710</a>: text changes and <a href="#">Figure 272: Transfer sequence diagram for master transmitter</a> modified.</li> <li>– <a href="#">Figure 273: Method 1: transfer sequence diagram for master receiver</a> modified.</li> <li>– <a href="#">Overrun/underrun error (OVR) on page 715</a> clarified.</li> <li>– <a href="#">Section 25.3.7: DMA requests</a> and <a href="#">Section 25.3.8: Packet error checking</a> updated.</li> <li>– In <a href="#">Section 25.6.1: Control register 1 (I2C_CR1)</a>: note modified under STOP bit and notes modified under POS bit.</li> <li>– Receiver mode modified in DR bit description in <a href="#">Section 25.6.5: Data register (I2C_DR)</a>.</li> <li>– Note added to TxE and RxNE bit descriptions in <a href="#">Section 25.6.6: Status register 1 (I2C_SR1)</a>.</li> </ul> <p>Changes in FSMC section:</p> <ul style="list-style-type: none"> <li>– Data setup and Address hold min values corrected in <a href="#">Table 101: Programmable NOR/PSRAM access parameters</a>.</li> <li>– Memory wait min value corrected in <a href="#">Table 126: Programmable NAND/PC Card access parameters</a>.</li> <li>– Bit descriptions modified in <a href="#">SRAM/NOR-Flash chip-select timing registers 1..4 (FSMC_BTR1..4) on page 504</a>.</li> <li>– DATAST and ADDHLD are reserved when equal to 0x0000 in <a href="#">SRAM/NOR-Flash chip-select timing registers 1..4 (FSMC_BTR1..4) on page 504</a> and <a href="#">SRAM/NOR-Flash write timing registers 1..4 (FSMC_BWTR1..4) on page 506</a>.</li> <li>– Bit descriptions modified in <a href="#">Common memory space timing register 2..4 (FSMC_PMEM2..4)</a></li> <li>– ATTHOLDx and ATTWAITx bit descriptions modified in <a href="#">Attribute memory space timing registers 2..4 (FSMC_PATT2..4)</a></li> <li>– IOHOLDx bit description modified in <a href="#">I/O space timing register 4 (FSMC_PIO4)</a></li> </ul>



Table 230. Document revision history (continued)

Date	Revision	Changes
22-Jun-2009	9	<p>Reference manual updated to support also STM32F105xx/STM32F107xx connectivity line devices.</p> <p><i>Memory and bus architecture</i> section: <i>Embedded boot loader</i> updated.</p> <p><i>Section 3.3: CRC functional description</i> updated.</p> <p>Note modified in <i>Section 4.1.2: Battery backup domain</i>.</p> <p><i>Connectivity line devices: reset and clock control (RCC)</i> section: <i>Figure 10: Simplified diagram of the reset circuit</i> updated. PLL1 changed to PLL. Note added to BDP bit description in <i>Section 4.4.1: Power control register (PWR_CR)</i>. <i>Table 55: SPI3/I2S3 remapping</i> corrected.</p> <p>DMA section: <i>Table 63: Programmable data width &amp; endian behavior (when bits PINC = MINC = 1)</i> updated, <i>Section 10.3.1: DMA transactions and Pointer incrementation on page 200</i> modified. <i>DMA channel x peripheral address register (DMA_CPARx) (x = 1..7), where x = channel number</i> and <i>DMA channel x memory address register (DMA_CMARx) (x = 1..7), where x = channel number</i> must not be written when the channel is enabled.</p> <p>Advanced-control timer section: <i>Section 13.3.12: Using the break function on page 295</i> updated. BKE and BKP bit descriptions updated in <i>Section 13.4.18: TIM1&amp;TIM8 break and dead-time register (TIMx_BDTR)</i>. CC1IF bit description modified in <i>Section 13.4.5: TIM1&amp;TIM8 status register (TIMx_SR)</i> and <i>Section 14.4.5: TIMx status register (TIMx_SR)</i>.</p> <p>Note added to <i>Table 80: TIMx Internal trigger connection</i> and <i>Table 84: TIMx Internal trigger connection on page 375</i>.</p> <p><i>Table 105: NOR Flash/PSRAM supported memories and transactions on page 478</i> and <i>Single-burst transfer</i> modified.</p> <p>Register numbering and address offset corrected in <i>Section 21.9.6: SDIO response 1..4 register (SDIO_RESPx) on page 568</i>.</p> <p>In <i>Section 23: Controller area network (bxCAN)</i>: DBF bit reset value and access type modified, small text changes.</p> <p>SPI section: note added in <i>Section 24.2.2: I2S features. Slave select (NSS) pin management</i> clarified. Note added at the end of <i>Section 24.3.3: Configuring the SPI in master mode</i> and <i>Section 24.3.4: Configuring the SPI for Simplex communication</i>.</p> <p>Audio frequency precision tables <i>181</i> and <i>182</i> added to <i>Section 24.4.3: Clock generator on page 684</i> and audio sampling frequency range increased to 96 kHz.</p> <p><i>Arbitration lost (ARLO) on page 715</i> specified.</p> <p>USART section: Description of "1.5 stop bits" updated in <i>Configurable stop bits, RTS flow control</i> corrected. Procedure sequence modified in <i>Section 26.3.2: Transmitter. How to derive USARTDIV from USART_BRR register values</i> modified. <i>Section 26.3.5: USART receiver's tolerance to clock deviation</i> added. <i>Section 26.3.11: Smartcard</i> and <i>Section 26.3.10: Single-wire half-duplex communication</i> updated. Bit 12 description modified in <i>Section 26.6.4: Control register 1 (USART_CR1)</i>.</p> <p><i>Debug support (DBG)</i> section:</p> <ul style="list-style-type: none"> <li>– <i>Figure 361: Block diagram of STM32F10xxx-level and Cortex-M3-level debug support</i> updated</li> <li>– <i>Section 30.15: ETM (Embedded Trace Macrocell)</i> added</li> <li>– <i>Figure 364: TPIU block diagram</i> updated</li> <li>– in <i>DBGMCU_IDCODE</i>, REV_ID(15:0) updated for connectivity line devices (revision Z added).</li> </ul> <p><i>Section 27: USB on-the-go full-speed (OTG_FS)</i> revised. Small text changes.</p>

**Table 230. Document revision history (continued)**

Date	Revision	Changes
04-Dec-2009	10 (to be continued on next page)	<p>References to the STM32F10xxx Cortex-M3 programming manual (PM0056) made throughout the document.</p> <p>The GPIO, AFIO, EXTI, ADC, DAC, CAN, FSMC, SDIO, USB_OTG registers are accessed by words (32 bits).</p> <p>The PWR, BKP, USART, SPI, I2C, TIM1&amp;8, TIMx, TIM6&amp;7, WWDG, IWDG, USB, RTC registers are accessed by words (32 bits) or by half-words (16 bits).</p> <p>The DMA registers are accessed by byte (8 bits), by words (32 bits) or by half-words (16 bits).</p> <p>Upper USB OTG FS boundary address corrected in <a href="#">Table 1: Register boundary addresses</a>.</p> <p>Note 4 modified in <a href="#">Reading the Flash memory</a>.</p> <p><a href="#">Section 7.2: Clocks</a> updated. <a href="#">Figure 11: Clock tree</a> modified. <a href="#">Exiting Standby mode</a> modified. Caution added to the HPRE bit description and bit 22 description modified in <a href="#">Section 7.3.2: Clock configuration register (RCC_CFGR)</a>.</p> <p><a href="#">Section 7.1.2: Power reset</a> and <a href="#">Section 6.1.2: Power reset</a> modified, <a href="#">Figure 7: Simplified diagram of the reset circuit</a> and <a href="#">Figure 10: Simplified diagram of the reset circuit</a> modified.</p> <p>HSE frequency range corrected in <a href="#">Section 6.3: RCC registers</a>.</p> <p>“USB” table replaced by <a href="#">Table 28: OTG_FS pin configuration</a>.</p> <p>Address offsets corrected in <a href="#">Section 10.4: DMA registers</a>.</p> <p>Note added to <a href="#">Table 68: ADC pins</a> and V<sub>DMA</sub> description modified.</p> <p><a href="#">Figure 179: RTC simplified block diagram</a> modified.</p> <p>Frequency changed in <a href="#">Table 94: Min/max IWDG timeout period at 40 kHz (LSI)</a>.</p> <p>Text changes in <a href="#">Section 19.4: How to program the watchdog timeout</a>.</p> <p>FSMC_TCR changed to FSMC_BTR in <a href="#">Section 20: Flexible static memory controller (FSMC)</a>.</p> <p><a href="#">Section 24: Serial peripheral interface (SPI)</a> structure revised.</p> <p>NSS description clarified in <a href="#">Section 24.3.1: General description</a>.</p> <p><a href="#">Section 24.2.2: I2S features</a> modified. Note added to <a href="#">Section 24.3.2: Configuring the SPI in slave mode</a>. <a href="#">Figure 239: Data clock timing diagram</a> modified. <a href="#">Section 24.3.4: Configuring the SPI for Simplex communication</a> clarified. <a href="#">Section 24.3.5: Data transmission and reception procedures</a> added.</p> <p><a href="#">Section 24.3.6: CRC calculation</a> clarified. <a href="#">Section 24.3.7: Status flags</a> updated.</p> <p><a href="#">Section 24.3.8: Disabling the SPI</a> updated. <a href="#">Section 24.3.9: SPI communication using DMA (direct memory addressing)</a> updated. <a href="#">Section 24.3.10: Error flags</a> modified.</p> <p><a href="#">Section 24.4.3: Clock generator</a> updated. Note added to bit 6 (SPE) in <a href="#">Section 24.5.1: SPI control register 1 (SPI_CR1) (not used in I2S mode)</a>. Note removed from the descriptions of bits 6 and 7 in <a href="#">Section 24.5.2: SPI control register 2 (SPI_CR2)</a>. Note added to bit 7 (BSY) in <a href="#">Section 24.5.3: SPI status register (SPI_SR)</a>.</p> <p><a href="#">Section 24.4.4: I2S master mode</a> modified.</p> <p><a href="#">Closing the communication</a> specified. <a href="#">Bus error (BERR)</a> modified. CCR bit definition modified in <a href="#">Section 25.6.8: Clock control register (I2C_CCR)</a>.</p> <p>Bit 14 definition modified in <a href="#">Section 25.6.3: Own address register 1 (I2C_OAR1)</a>.</p> <p>Note added to <a href="#">Table 193: USART interrupt requests</a>. SCLK replaced by CK throughout <a href="#">Section 26: Universal synchronous asynchronous receiver transmitter (USART)</a>.</p> <p><a href="#">Figure 281: TC/TXE behavior when transmitting</a> clarified. <a href="#">Start bit detection</a> modified.</p> <p><a href="#">Transmission using DMA</a> updated. <a href="#">Figure 296: Transmission using DMA</a> added.</p> <p><a href="#">Figure 297: Reception using DMA</a> added.</p>

Table 230. Document revision history (continued)

Date	Revision	Changes
04-Dec-2009	10 continued	<p>TXFELVL bit description modified in <i>OTG_FS AHB configuration register (OTG_FS_GAHBCFG)</i>.</p> <p>NPTXFE bit description modified in <i>OTG_FS core interrupt register (OTG_FS_GINTSTS)</i>.</p> <p>NPTXFEM bit description modified in <i>OTG_FS interrupt mask register (OTG_FS_GINTMSK)</i>.</p> <p><i>Figure 311: Transmit FIFO write task</i> modified.</p> <p>Bit 22 is reserved in <i>OTG_FS interrupt mask register (OTG_FS_GINTMSK)</i>.</p> <p>Bit 29 description modified in <i>OTG device endpoint-x control register (OTG_FS_DIEPCTLx)</i> (<math>x = 1..3</math>, where <math>x = \text{Endpoint\_number}</math>).</p> <p>Bits 21:20 no longer reserved in <i>OTG_FS host channel-x characteristics register (OTG_FS_HCCHARx)</i> (<math>x = 0..7</math>, where <math>x = \text{Channel\_number}</math>).</p> <p>There are only 4 IN and OUT endpoints:</p> <ul style="list-style-type: none"> <li>– Bit descriptions corrected in <i>OTG_FS device all endpoints interrupt register (OTG_FS_DAIN)</i>.</li> <li>– Bits 15:0 description corrected in <i>OTG_FS device IN endpoint FIFO empty interrupt mask register: (OTG_FS_DIEPEMPMSK)</i> (there are only 4 endpoints).</li> <li>– <i>Table 202: OTG_FS register map and reset values</i> corrected</li> </ul> <p>Note added to <i>Section 28.4: Ethernet functional description: SMI, MII and RMI</i> on page 916.</p> <p>Note added to <i>Unicast destination address filter</i> and <i>Multicast destination address filter. System consideration during power-down on page 946</i> updated.</p> <p><i>Figure 325: ETH block diagram</i> modified. CIC bit description modified in <i>TDES0: Transmit descriptor Word0</i> and <i>TDES0: Transmit descriptor Word0: Transmit time stamp control and status on page 967</i>.</p> <p><i>Ethernet MAC hash table high register (ETH_MACHTHR)</i> description clarified.</p> <p>Description of bits 6:2 modified in <i>Ethernet DMA bus mode register (ETH_DMABMR)</i>.</p> <p>Peripheral register access specified in <i>Section 28.8: Ethernet register descriptions</i>.</p>
23-Apr-2010	11	<p>XL-density devices added.</p> <p><i>Flash access control register (FLASH_ACR)</i> inserted.</p> <p><i>External source (HSE bypass)</i> and <i>External source (HSE bypass)</i> : maximum HSE frequency modified.</p> <p>HSEBYP bit description modified in <i>Section 6.3.1: Clock control register (RCC_CR)</i> and <i>Section 7.3.1: Clock control register (RCC_CR)</i>.</p> <p>SPI3_REMAP definition modified in <i>Section 8.4.2: AF remap and debug I/O configuration register (AFIO_MAPR)</i>.</p> <p><i>Figure 22: DMA block diagram in connectivity line devices</i> modified.</p> <p><i>Figure 85: Center-aligned PWM waveforms (ARR=8)</i> modified.</p> <p>OIS1N and OIS1 bit descriptions modified in <i>Section 13.4.2: TIM1&amp;TIM8 control register 2 (TIMx_CR2)</i>.</p> <p>FSMC block diagram reinserted.</p> <p><i>Figure 202: Synchronous multiplexed read mode - NOR, PSRAM (CRAM)</i> modified.</p> <p>FSMC_ECCR2 and FSMC_ECCR3 reset value modified in <i>Table 133: FSMC register map</i>.</p> <p>Updated I2C Master mode <i>Slave address transmission on page 708</i></p> <p>Notes modified in the bit 5 descriptions in <i>OTG_FS core interrupt register (OTG_FS_GINTSTS)</i> and <i>OTG_FS interrupt mask register (OTG_FS_GINTMSK)</i>.</p> <p><i>Transmission using DMA</i> updated.</p>

Table 230. Document revision history (continued)

Date	Revision	Changes
23-Apr-2010	11 continued	<p>Updated <a href="#">Section 20: Flexible static memory controller (FSMC)</a>,  Updated <a href="#">Section 20.3: AHB interface on page 471</a>  Updated <a href="#">Wrap support for NOR Flash/PSRAM on page 474</a>  Added ASYNCWAIT, in <a href="#">Table 106: FSMC_BCRx bit fields on page 481</a>  Added section <a href="#">WAIT management in asynchronous accesses on page 493</a>  Updated <a href="#">Figure 200: Asynchronous wait during a write access on page 495</a>  Updated <a href="#">Table 129: 16-bit PC Card on page 509</a>  Added <a href="#">Section 20.6.7: PC Card/CompactFlash operations on page 513</a>  Removed OTG_FS controller block diagram  Update <a href="#">Section 1.10.2: Peripheral Tx FIFOs</a>  Added <a href="#">Section 1.12: FIFO RAM allocation</a>  Updated <a href="#">Table 4: Core global control and status registers (CSRs)</a>  Added method 1 and 2 in <a href="#">Section 25.3.3: I2C master mode</a>  Updated note in POS bit description <a href="#">Section 25.6: I2C registers</a>  Removed NPTXRWEN bit in <a href="#">Section 27: USB on-the-go full-speed (OTG_FS)</a>  Updated formula for TRDT bit in <a href="#">Section 27: USB on-the-go full-speed (OTG_FS)</a>  Removed BIM and TXFURM bits <a href="#">OTG_FS device IN endpoint common interrupt mask register (OTG_FS_DIEPMSK)</a>  Removed BOIM, OPEM, B2BSTUP bits in <a href="#">OTG_FS device OUT endpoint common interrupt mask register (OTG_FS_DOEPMSK)</a>  Updated <a href="#">Section 30.6.2: Boundary scan TAP on page 1035</a></p>

## Index

### A

ADC_CR1	236
ADC_CR2	238
ADC_DR	247
ADC_HTR	243
ADC_JDRx	246
ADC_JOFRx	242
ADC_JSQR	246
ADC_LTR	243
ADC_SMPR1	241
ADC_SMPR2	242
ADC_SQR1	244
ADC_SQR2	244
ADC_SQR3	245
ADC_SR	235
AFIO_EVCR	169
AFIO_EXTICR1	176
AFIO_EXTICR2	176
AFIO_EXTICR3	177
AFIO_EXTICR4	177
AFIO_MAPR	170
AFIO_MAPR2	178

### B

BKP_CR	76
BKP_CSR	76
BKP_DRx	75
BKP_RTCCR	75

### C

CAN_BTR	639
CAN_ESR	638
CAN_FA1R	649
CAN_FFA1R	649
CAN_FiRx	650
CAN_FM1R	648
CAN_FMR	647
CAN_FS1R	648
CAN_IER	637
CAN_MCR	630
CAN_MSR	632
CAN_RDHxR	646
CAN_RDLxR	646
CAN_RDTxR	645
CAN_RF0R	635
CAN_RF1R	636

CAN_RiRx	644
CAN_TDHxR	643
CAN_TDLxR	643
CAN_TDTxR	642
CAN_TiRx	641
CAN_TSR	633
CRC_DR	57
CRC_IDR	57

### D

DBGMCU_CR	1048
DBGMCU_IDCODE	1034
DMA_CCRx	209
DMA_CMARx	211
DMA_CNDTRx	210
DMA_CPARx	211
DMA_IFCR	208
DMA_ISR	207

### E

ETH_DMABMR	1008
ETH_DMACHRBAR	1020
ETH_DMACHRDR	1020
ETH_DMACHTBAR	1020
ETH_DMACHTDR	1019
ETH_DMAIER	1017
ETH_DMAMFBOCR	1019
ETH_DMAOMR	1014
ETH_DMARDLAR	1010
ETH_DMARPDR	1010
ETH_DMASR	1011
ETH_DMATDLAR	1010
ETH_DMATPDR	1009
ETH_MACA0HR	993
ETH_MACA0LR	994
ETH_MACA1HR	994
ETH_MACA1LR	995
ETH_MACA2HR	995
ETH_MACA2LR	996
ETH_MACA3HR	996
ETH_MACA3LR	997
ETH_MACCR	981
ETH_MACFCR	987
ETH_MACFFR	984
ETH_MACHTHR	985
ETH_MACHTLR	986
ETH_MACIMR	993

ETH_MACMIAR	986	I2C_TRISE	732
ETH_MACMIIDR	987	IWDG_KR	460
ETH_MACPMTCSR	991	IWDG_PR	461
ETH_MACRWUFFR	990	IWDG_RLR	462
ETH_MACSR	992	IWDG_SR	462
ETH_MACVLANTR	989		
ETH_MMCCR	998	<b>O</b>	
ETH_MMCRFAECR	1002	OTG_FS_CID	826
ETH_MMCRFCECR	1002	OTG_FS_DAIN	843
ETH_MMCRGUFCR	1003	OTG_FS_DAINMSK	844
ETH_MMCRIMR	1000	OTG_FS_DCFG	838
ETH_MMCRIR	998	OTG_FS_DCTL	839
ETH_MMCTGFCR	1002	OTG_FS_DIEPCTL0	846
ETH_MMCTGFMSCCR	1001	OTG_FS_DIEPEMPMSK	845
ETH_MMCTGFSCCR	1001	OTG_FS_DIEPINTx	854
ETH_MMCTIMR	1000	OTG_FS_DIEPMSK	841
ETH_MMCTIR	999	OTG_FS_DIEPTSIZ0	856
ETH_PTPSSIR	1004	OTG_FS_DIEPTSIZx	858
ETH_PTPTSAR	1006	OTG_FS_DIEPTXFx	827
ETH_PTPTSCR	1003	OTG_FS_DOEPCTL0	850
ETH_PTPTSHR	1004	OTG_FS_DOEPCTLx	851
ETH_PTPTSHUR	1005	OTG_FS_DOEPINTx	855
ETH_PTPTSLR	1005	OTG_FS_DOEPMSK	842
ETH_PTPTSLUR	1006	OTG_FS_DOEPTSIZ0	857
ETH_PTPTTHR	1007	OTG_FS_DOEPTSIZx	859
ETH_PTPTTLR	1007	OTG_FS_DSTS	840
EXTI_EMR	193	OTG_FS_DTXFSTSx	859
EXTI_FTSR	194	OTG_FS_DVBUSDIS	844
EXTI_IMR	193	OTG_FS_DVBUSPULSE	845
EXTI_PR	195	OTG_FS_GAHBCFG	810
EXTI_RTSR	194	OTG_FS_GCCFG	825
EXTI_SWIER	195	OTG_FS_GINTMSK	819
		OTG_FS_GINTSTS	815
<b>G</b>		OTG_FS_GNPTXFSIZ	824
GPIOx_BRR	160	OTG_FS_GNPTXSTS	824
GPIOx_BSRR	159	OTG_FS_GOTGCTL	806
GPIOx_CRH	158	OTG_FS_GOTGINT	808
GPIOx_CRL	157	OTG_FS_GRSTCTL	813
GPIOx_IDR	158	OTG_FS_GRXFSIZ	823
GPIOx_LCKR	160	OTG_FS_GRXSTSP	822
GPIOx_ODR	159	OTG_FS_GRXSTSR	822
		OTG_FS_GUSBCFG	811
<b>I</b>		OTG_FS_HAINT	830
I2C_CCR	731	OTG_FS_HAINTMSK	831
I2C_CR1	722	OTG_FS_HCCHARx	834
I2C_CR2	724	OTG_FS_HCFG	827
I2C_DR	726	OTG_FS_HCINTMSKx	836
I2C_OAR1	725	OTG_FS_HCINTx	835
I2C_OAR2	726	OTG_FS_HCTSIZx	837
I2C_SR1	727	OTG_FS_HFIR	828
I2C_SR2	730	OTG_FS_HFNUM	829

OTG_FS_HPRT .....	831	SPI_I2SPR .....	700
OTG_FS_HPTXFSIZ .....	826	SPI_RXCR .....	698
OTG_FS_HPTXSTS .....	829	SPI_SR .....	695
OTG_FS_PCGCTL .....	860	SPI_TXCR .....	698
<b>P</b>			
PWR_CR .....	69	<b>T</b>	
PWR_CSR .....	71	TIMx_ARR .....	386, 422, 432, 445
<b>R</b>			
RCC_AHBENR .....	102, 133, 141	TIMx_BDTR .....	330
RCC_APB1ENR .....	105, 136	TIMx_CCER .....	324, 384, 421, 431
RCC_APB1RSTR .....	99, 130	TIMx_CCMR1 .....	320, 379, 418, 428
RCC_APB2ENR .....	103, 134	TIMx_CCMR2 .....	323, 383
RCC_APB2RSTR .....	97, 129	TIMx_CCR1 .....	328, 386, 423, 433
RCC_BDCR .....	108, 138	TIMx_CCR2 .....	329, 387, 423
RCC_CFGR .....	92, 123, 142	TIMx_CCR3 .....	329, 387
RCC_CIR .....	95, 126	TIMx_CCR4 .....	330, 388
RCC_CR .....	90, 121	TIMx_CNT .....	327, 385, 422, 432, 444
RCC_CSR .....	109, 140	TIMx_CR1 .....	310, 371, 412, 424, 441
RTC_ALRH .....	456	TIMx_CR2 .....	311, 372, 413, 425, 443
RTC_ALRL .....	456	TIMx_DCR .....	332, 388
RTC_CNTH .....	455	TIMx_DIER .....	315, 376, 415, 426, 443
RTC_CNTL .....	456	TIMx_DMAR .....	333, 389
RTC_CRH .....	452	TIMx_EGR .....	318, 378, 417, 427, 444
RTC_CRL .....	452	TIMx_PSC .....	327, 386, 422, 432, 445
RTC_DIVH .....	455	TIMx_RCR .....	328
RTC_DIVL .....	455	TIMx_SMCR .....	313, 373, 414
RTC_PRLH .....	454	TIMx_SR .....	317, 377, 416, 426, 444
RTC_PRL .....	454	<b>U</b>	
<b>S</b>			
SDIO_CLKCR .....	565	USART_BRR .....	769
SDIO_DCOUNT .....	571	USART_CR1 .....	770
SDIO_DCTRL .....	570	USART_CR2 .....	772
SDIO_DLEN .....	569	USART_CR3 .....	773
SDIO_DTIMER .....	569	USART_DR .....	768
SDIO_FIFO .....	578	USART_GTPR .....	775
SDIO_FIFOCNT .....	577	USART_SR .....	766
SDIO_ICR .....	573	USB_ADDRn_RX .....	606
SDIO_MASK .....	575	USB_ADDRn_TX .....	605
SDIO_POWER .....	565	USB_BTABLE .....	600
SDIO_RESPCMD .....	568	USB_CNTR .....	594
SDIO_RESPx .....	568	USB_COUNTn_RX .....	606
SDIO_STA .....	572	USB_COUNTn_TX .....	605
SPI_CR1 .....	693	USB_DADDR .....	599
SPI_CR2 .....	695	USB_EPnR .....	600
SPI_CRCPR .....	697	USB_FNR .....	599
SPI_DR .....	697	USB_ISTR .....	596
SPI_I2SCFGR .....	699	<b>W</b>	
		WWDG_CFR .....	467
		WWDG_CR .....	467
		WWDG_SR .....	468

**Please Read Carefully:**

Information in this document is provided solely in connection with ST products. STMicroelectronics NV and its subsidiaries ("ST") reserve the right to make changes, corrections, modifications or improvements, to this document, and the products and services described herein at any time, without notice.

All ST products are sold pursuant to ST's terms and conditions of sale.

Purchasers are solely responsible for the choice, selection and use of the ST products and services described herein, and ST assumes no liability whatsoever relating to the choice, selection or use of the ST products and services described herein.

No license, express or implied, by estoppel or otherwise, to any intellectual property rights is granted under this document. If any part of this document refers to any third party products or services it shall not be deemed a license grant by ST for the use of such third party products or services, or any intellectual property contained therein or considered as a warranty covering the use in any manner whatsoever of such third party products or services or any intellectual property contained therein.

**UNLESS OTHERWISE SET FORTH IN ST'S TERMS AND CONDITIONS OF SALE ST DISCLAIMS ANY EXPRESS OR IMPLIED WARRANTY WITH RESPECT TO THE USE AND/OR SALE OF ST PRODUCTS INCLUDING WITHOUT LIMITATION IMPLIED WARRANTIES OF MERCHANTABILITY, FITNESS FOR A PARTICULAR PURPOSE (AND THEIR EQUIVALENTS UNDER THE LAWS OF ANY JURISDICTION), OR INFRINGEMENT OF ANY PATENT, COPYRIGHT OR OTHER INTELLECTUAL PROPERTY RIGHT.**

**UNLESS EXPRESSLY APPROVED IN WRITING BY AN AUTHORIZED ST REPRESENTATIVE, ST PRODUCTS ARE NOT RECOMMENDED, AUTHORIZED OR WARRANTED FOR USE IN MILITARY, AIR CRAFT, SPACE, LIFE SAVING, OR LIFE SUSTAINING APPLICATIONS, NOR IN PRODUCTS OR SYSTEMS WHERE FAILURE OR MALFUNCTION MAY RESULT IN PERSONAL INJURY, DEATH, OR SEVERE PROPERTY OR ENVIRONMENTAL DAMAGE. ST PRODUCTS WHICH ARE NOT SPECIFIED AS "AUTOMOTIVE GRADE" MAY ONLY BE USED IN AUTOMOTIVE APPLICATIONS AT USER'S OWN RISK.**

Resale of ST products with provisions different from the statements and/or technical features set forth in this document shall immediately void any warranty granted by ST for the ST product or service described herein and shall not create or extend in any manner whatsoever, any liability of ST.

ST and the ST logo are trademarks or registered trademarks of ST in various countries.

Information in this document supersedes and replaces all information previously supplied.

The ST logo is a registered trademark of STMicroelectronics. All other names are the property of their respective owners.

© 2010 STMicroelectronics - All rights reserved

STMicroelectronics group of companies

Australia - Belgium - Brazil - Canada - China - Czech Republic - Finland - France - Germany - Hong Kong - India - Israel - Italy - Japan - Malaysia - Malta - Morocco - Philippines - Singapore - Spain - Sweden - Switzerland - United Kingdom - United States of America

[www.st.com](http://www.st.com)